

# SAIA<sup>®</sup> PLC

Programmable controllers

## Manuel of the series PCA 2 Hardware

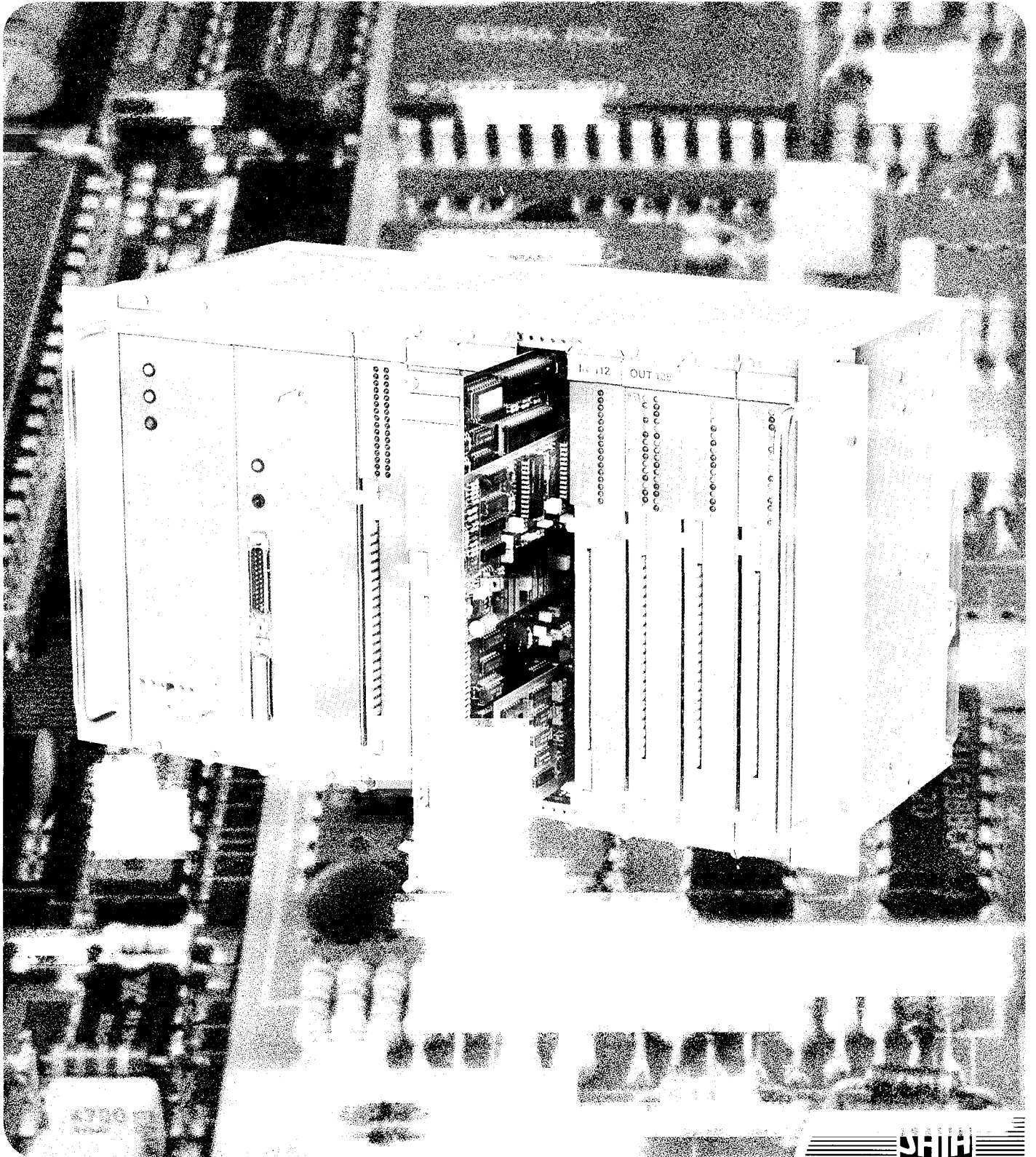

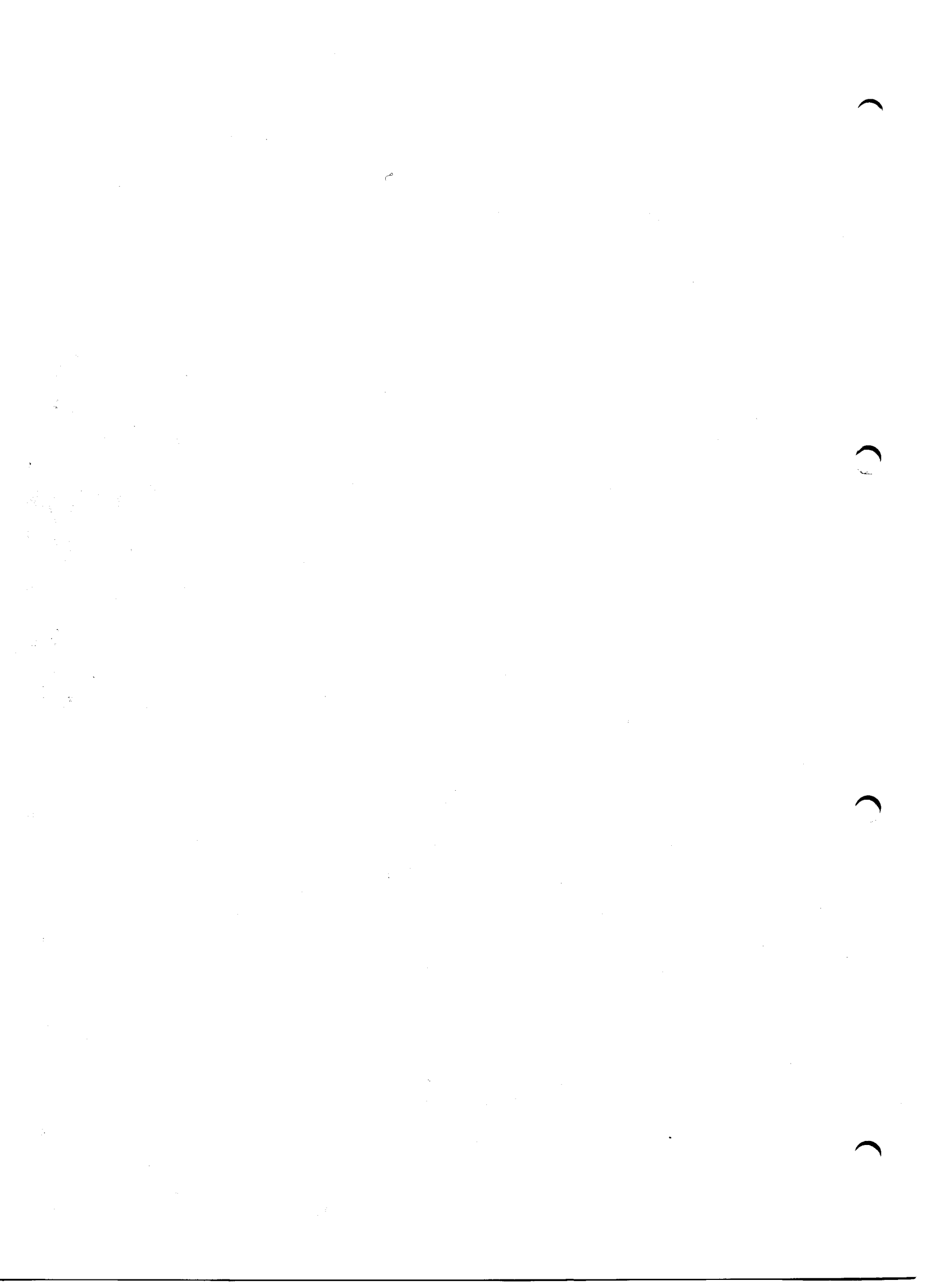

## **HARDWARE - PCA2**

### **GENERAL**

- PART A HOUSING, PROCESSOR AND POWER SUPPLY MODULES**
- PART B INPUT/OUTPUT MODULES as well as ADDITIONAL and DISPLAY MODULES**
- PART C OPERATING MODES**

Selling price SFr. 60.-

Summary of the manuals available

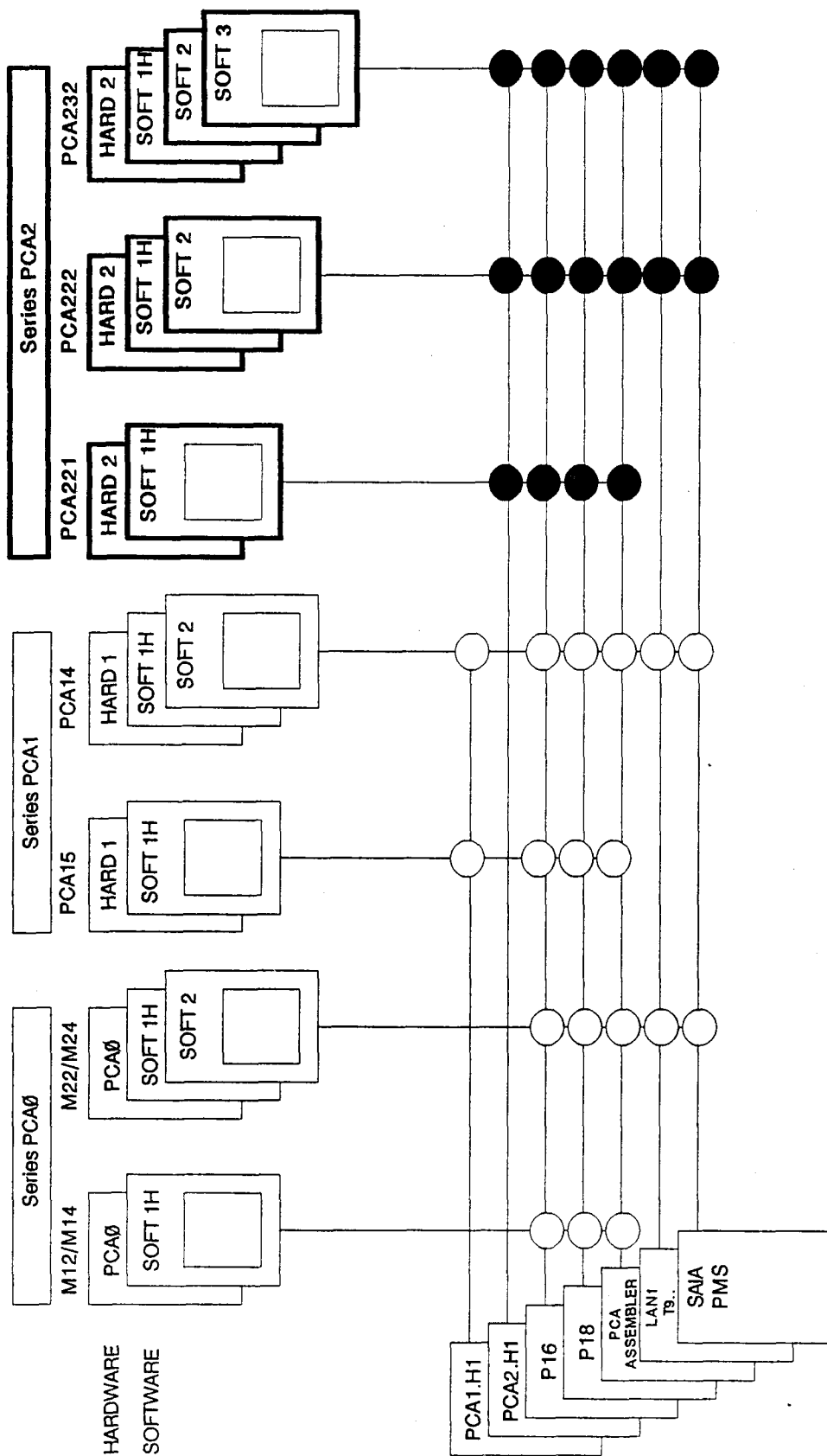

# Overview of the SAIA<sup>®</sup>PLC, system family PCA

Series PCA0	Series PCA1	Series PCA2
<p><b>Soft level 3</b></p> <p>Soft level 2                      + 32 word instructions for                      - arithmetic ± 9 digits                      - data transfer                      - word register</p>	<p><b>Series PCA1</b></p> <p>PCA141    PCA147    PCA157 + ..C45</p> <p>..M41    ..M47    ..M45</p> <p>32(56)    64(112)    128(224) I/O</p> <p>User memory                      max. 8K program steps                      max. 8K text characters/data</p>	<p><b>Series PCA2</b></p> <p>PCA232</p> <p>..C30</p> <p>..M32</p> <p>User memory                      - 8K program steps                      + 8K text characters                      + 8K byte data</p> <p>256 or 512 I/O</p>
<p><b>Soft level 2</b></p> <p>Soft level 1H                      + Serial interface                      + Data-time                      + Data register                      + Parameter instructions                      (soft interrupt, FIFO,                      PID)</p>	<p><b>Standard versions and OEM</b></p> <p>PCA0..M22    PCA0..M24</p> <p>..M22    ..M24</p> <p>max. 32 I/O    max. 64 I/O</p> <p>User memory                      max. 4K program steps                      max. 4K text characters/data</p>	<p>PCA222</p> <p>..C30</p> <p>..M22</p> <p>User memory                      max. 8K program steps                      max. 8K text characters/data</p> <p>256 or 512 I/O</p>
<p><b>Soft level 1H</b></p> <p>Instruction set with                      32 basic instructions for                      - timers and counters                      - parallel programs and                      subroutines                      - indexing, etc.</p> <p>20 additional instructions for                      - arithmetic                      - data transfer                      - check-sum</p>	<p><b>Standard versions</b></p> <p>PCA0..M12    PCA0..M14</p> <p>..M12    ..M14</p> <p>24/32 I/O    48/64 I/O</p> <p>User memory                      max. 4K program steps</p>	<p>PCA221</p> <p>..C30</p> <p>..M21</p> <p>User memory                      max. 8K program steps</p> <p>256 or 512 I/O</p>



## TABLE OF CONTENTS

		Page
<b>PART A</b>	<b>BASIC MODULES</b>	
A 1	System structure	1A
A 1.1	SAIA°PLC block circuit diagram	1A
A 1.2	Functional description of the SAIA°PLC	2A
A 2	PCA2.M21 Processor module (software level 1H)	4A
A 3	PCA2.M22 Processor module (software level 2)	10A
A 4	PCA2.M32 Processor module (software level 3)	16A
A 5	User memory modules Type PCA2.R26 memory modules, Type PCA2.R27 memory module with date-time	25A
A 6	Power supply modules	28A
A 6.1	Type PCA2.N20/N21 Power supply module for 24VDC	28A
A 6.2	Type PCA2.N30/N31 Power supply module for AC-voltage	30A
A 7	Type PCA2.C.. Rack units	33A
A 7.1	Type PCA2.C21 Rack units with 8 I/O plug-in locations	33A
A 7.2	Type PCA2.C21 and C30 Extension housing for I + O > 256	34A
A 8	Type PCA2.K.. System cables	35A
A 8.1	Cable routing with system cables and external interfaces	36A
A 8.2	Interference immunity	36A
A 8.3	Dimensions of the PCA2 series	40A
A 9	Brief description for operation a PCA2	41A
<b>PART B</b>	<b>IN-/OUTPUT MODULES as well as AUXILIARY and DISPLAY MODULES</b>	
B 1	Plug-in input/output modules	1B
B 1.1	Digital input modules	1B
B 1.1.1	Type PCA2.E10 Input module, electrically connected	3B
B 1.1.2	Type PCA2.E11 Input module for NAMUR-proximity switch	6B
B 1.1.3	Type PCA2.E20 Input module, opto-isolated	7B
B 1.1.4	Type PCA2.E30 Input module for NAMUR-proximity switch	9B
B 1.1.5	Type PCA2.E60 Input module, opto-isolated	13B
B 1.2	Digital output modules	14B
B 1.2.1	Type PCA2.A10 Output module, electrically connected for 0.1A	14B
B 1.2.2	Type PCA2.A21 Output module with relay contacts	16B
B 1.2.3	Type PCA2.A31 Output module, opto-isolated for 2A	18B
B 1.2.4	Type PCA2.A40 Output module, electrically connected for 0.5A	21B
B 1.3	Analog input and output modules	24B
B 1.3.1	Type PCA2.W1.. 12-bit analog input and output modules	24B
B 1.3.2	Type PCA2.W2.. Analog input modules with 8-bit resolution	31B
B 1.4	Type PCA2.H1.. Counter module for 10...200kHz	35B
B 1.4.1	Type PCA2.H1.. Counter module	36B
B 1.4.2	Type PCA2.H11 Additional counting mode module	43B
B 1.4.3	Type PCA2.H12/H13 Additional step motor module	44B

B 1.5	Type PCA2.F20 Data line switching module for processor module M22 and M32	45B
B 1.6	Selection of power supply modules depending on the power requirements of the PCA2 I/O modules	58B
B 2	Programming units, additional units and accessories	60B
B 2.1	Programming units	61B
B 2.1.1	Hand-held programming unit PCA2.P05	61B
B 2.1.2	Input simulation unit PCA2.S10	62A
B 2.1.3	Programming unit PCA2.P18	63B
B 2.1.4	SAIA°PCA-ASSEMBLER	64B
B 2.1.5	Type PCA2.P16 EPROM-copying unit	67B
B 2.1.6	Type PCA1.R95/R96 Buffered RAM-chip	70B
B 2.2	Display modules	71B
B 2.2.1	Type PCA2.D12 Display module	71B
B 2.2.2	Type PCA2.D13 Display interface	78B
B 2.2.3	Type PCA2.D14 Display module	81B
B 2.3	KOM series external interface module	85B
B 2.3.1	Type KOM 111B Dual-input interface	85B
B 2.3.2	Type KOM 121B Dual-relay-output interface	86B
B 2.4	Dimensions of additional units	87B
B 2.5	Dimensions and installation of PCA2.D12	89B
B 2.6	Dimensions and installation of PCA2.D14	90B

## PART C OPERATING MODES

C 1	Basic operating modes	2C
C 1.1	Summary of operating modes	3C
C 1.2	Detailed description of operating modes	4C
C 2	Further operating modes (only for PCA2.M22 and M32)	7C
C 2.1	"TEST" = checking of the ACCU state of the bit processor in the RUN-mode (only PCA2.M32)	7C
C 2.2	"MAN" or "MAN BIT"	7C
C 2.3	"TEXT" or text memory as data register	10C
C 2.4	"MAN BCD" = manual access to the word register as well as to the data register of the user memory (only for PCA2.M32)	14C
C 2.5	"LCM" = Load Copy Memory (only PCA2.M32)	20C
C 2.6	List of modules	21C



**PART A      HARDWARE**

**Chapter A 1    System structure**

**Chapter A 2    PCA2.M21 processor module (software level 1H)**

**Chapter A 3    PCA2.M22 processor module (software level 2)**

**Chapter A 4    PCA2.M32 processor module (software level 3)**

**Chapter A 5    User memory modules**

**Chapter A 6    Power supply modules**

**Chapter A 7    Rack units PCA2.C..**

**Chapter A 8    System cables PCA2.K..**

**Chapter A 9    Brief instruction for operating a PCA2**



**PART A Hardware**

**A 1 System structure**

**A 1.1 SAIA°PLC block circuit diagram**

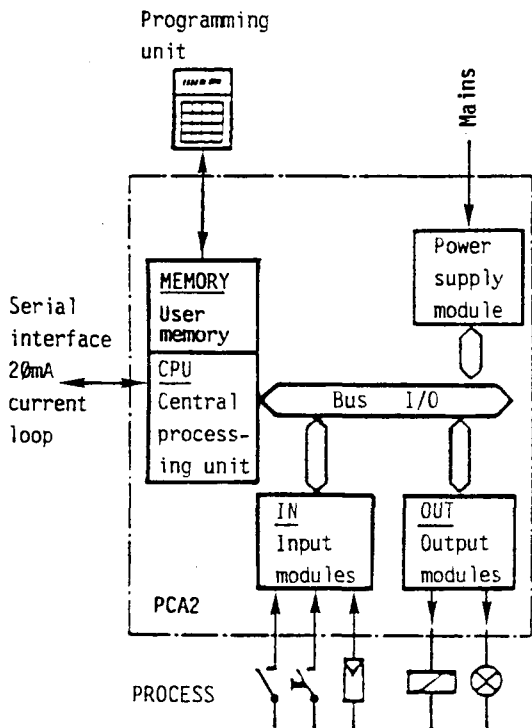

The SAIA°PLC is subdivided into the following hardware modules:

- Central processing unit CPU (also referred to as processor module)
- User MEMORY
- POWER SUPPLY module
- Input modules
- Output modules
- Rack-bus at the rear of the PCA2 extension housing

All listed modules can be plugged onto the common bus. Program input takes place via the programming unit which can be plugged onto the CPU.

- Slide-in housing
- Power supply module
- Processor module with CPU and MEMORY

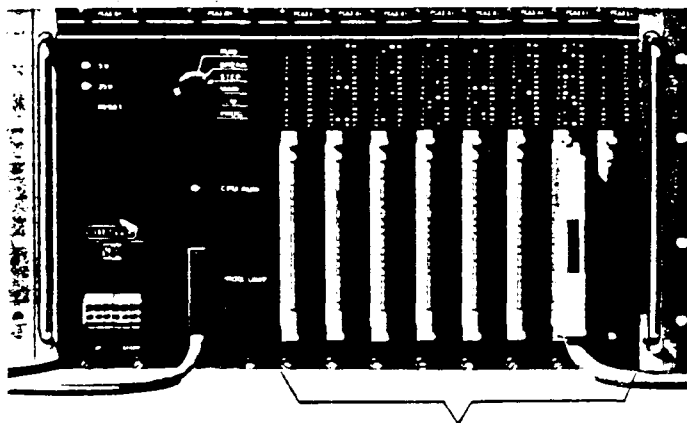

8 sockets for optional arrangements of I/O modules and the communications module. A second slide-in housing can be connected via a bus extension cable.

## A 1.2 Functional description of the SAIA<sup>®</sup>PLC

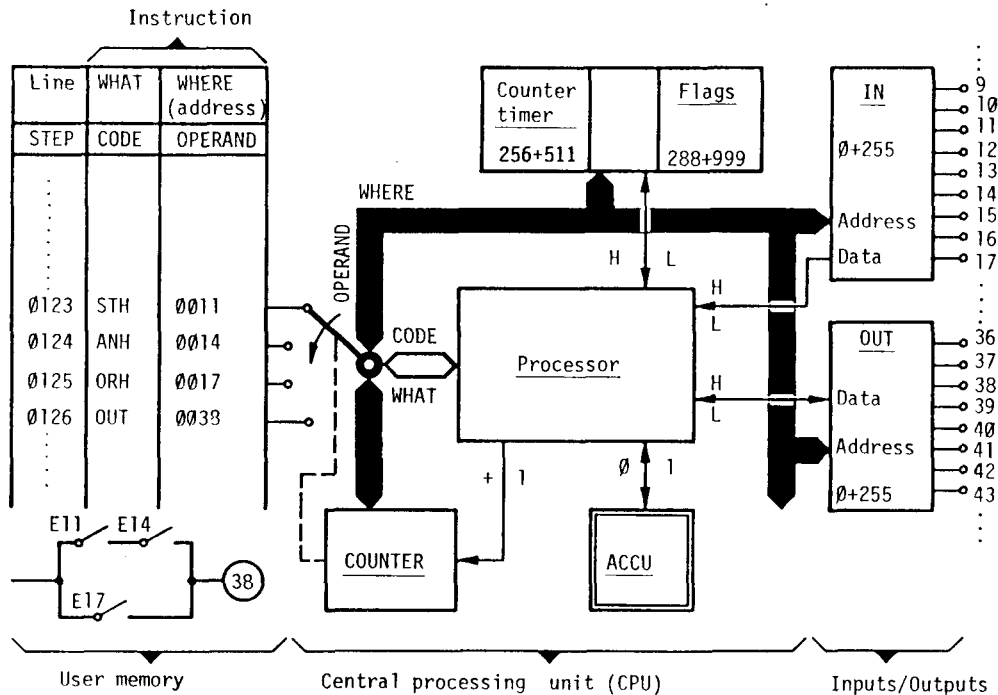

The instructions for linking the input signals and formation of the actual output states are entered by the user in the user memory, arranged in "words". Each word having a length of 16 bits comprises a complete instruction, subdivided into CODE and OPERAND. The CODE states "what" is to be executed, whilst the OPERAND states "where" the element under consideration is located.

The instructions are read and interpreted consecutively by the CPU. After an instruction has been processed, the step counter is incremented by 1 and the next instruction in the user memory is read. Additionally, the logical states of the elements (H or L) are interrogated by the CPU via the data bus. The result of each logic operation is stored in the accumulator (ACCU). The results are transmitted, for example, to outputs with an output instruction.

The CPU contains all units required for auxiliary functions, such as e.g.: timer and counter registers, flag memories, index registers etc. The return address for subroutines are stored in the auxiliary registers.

PCA2.M32					<b>User memory</b> 8K program lines of 16 bit <sup>1)</sup>
					<b>Text memory</b> 8K ASCII-characters of 8 bit <sup>1)</sup>
					<b>Data memory</b> 8K data of 8 bit <sup>1)</sup>
					<b>Word processor</b> 1K word register of 8 bit/2 digits BCD
					<b>Timer, counter or arithmetic register</b> 256 registers of 16 bit
PCA2.M22					<b>User memory</b> 4...8K program lines of 16 bit <sup>2)</sup>
					<b>Text memory</b> 0...8K ASCII-characters of 8 bit <sup>2)</sup>
					<b>Data memory</b> 0...8K data of 8 bit <sup>2)</sup>
					<b>Timer, counter or arithmetic register</b> 224 registers of 16 bit
PCA2.M21					<b>User memory</b> 8K program lines of 16 bit
					<b>Timer, counter or arithmetic register</b> 64 registers of 16 bit

- 1) Standard division of the entire storage capacity of 32K byte. Other divisions are possible, however, with limitations concerning the programming units.
- 2) The total storage capacity amounts to 16K byte, 8K byte of which can be defined in packets of 2K bytes as user, text and/or data memory. Two sockets are available for the text and data memory onto which either a RAM or EPROM can be plugged.

Summary of the performance levels and functions available		PCA2.M21	PCA2.M22	PCA2.M32
Capable of communicating and being integrated into a network	<b>Level ③</b> <ul style="list-style-type: none"> <li>● Arithmetic functions in the word register: +/÷/×/√ /COMP, computing capacity ± 999 999 999</li> <li>● Data transfer in the word register</li> <li>● Data transfer to and from the word register</li> </ul>			
	<b>Level ②</b> <ul style="list-style-type: none"> <li>● Input and output of data via the data interface: texts, numerical data, contents of the timer and counter register or date-time, state of inputs/outputs, etc.</li> <li>● Transmission parameters for the data interface and communication modes</li> <li>● Data transfer between data memory, counter register and date-time</li> <li>● Parameters for generating up to 32 PID control loops</li> <li>● Interrupt management, exclusive operation of parallel programs</li> <li>● Creation of rotation, shift or stack registers (FIFO)</li> </ul>			
Incapable of communicating	<b>Level ①H</b> <ul style="list-style-type: none"> <li>● Arithmetic functions in the counter register: +/÷/×, computing capacity + 65 535</li> <li>● Input and output of BCD- or binary coded values in the timer and counter register</li> <li>● Data transfer between index and counter register</li> <li>● Verification of the system and user memory (Check-Sum)</li> <li>● Parallel program and subroutine technology</li> <li>● Indexing (serial processing)</li> <li>● Jump and wait instructions</li> <li>● Timing and counting functions</li> <li>● Setting of outputs or flags</li> <li>● Edge detection of input signals (DYN)</li> <li>● Logic linkages (AND, OR, XOR, etc.)</li> <li>● Interrogation of inputs or outputs, flags, etc.</li> </ul>			

## A 2 PCA2.M21 Processor module (software level 1H)

### Technical data

CPU	$\mu$ P 8085.2, system program V6.21 <sup>1)</sup>
Cycle time	70 $\mu$ s per program line (average of logic instructions)
Instruction set	Software level 1H 32 basic instructions + 20 additional instructions for transfer functions, arithmetics (+, -, x, $\div$ ) and check sum
Parallel programs and subroutines	Up to 16 parallel programs, any number of subroutines nested down through 3 levels
Index register	16 (1 per parallel program, capacity of 255)
User memory	8K (4K + 4K) program lines on EPROM, RAM or buffered RAM chip on two sockets
Inputs and outputs	256 or 512 (with extension housing 256 I + 256 O)
Flag memory	712 flags, 235 of which are non-volatile 477 are volatile or non-volatile <sup>2)</sup>
Timer and counter or arithmetic registers	32 timer or counter registers + 32 counter registers, volatile <sup>2)</sup>
Counting or computing capacity	65'535 ( $2^{16}-1$ ) per counter register, may be increased as desired by means of cascading
Time range	0.1...6553s (0.01...655s) <sup>2)</sup>

<sup>1)</sup> When switching on the PLC, the CPU system version is displayed on the programming unit ..P10 or ..P05 for about one second.

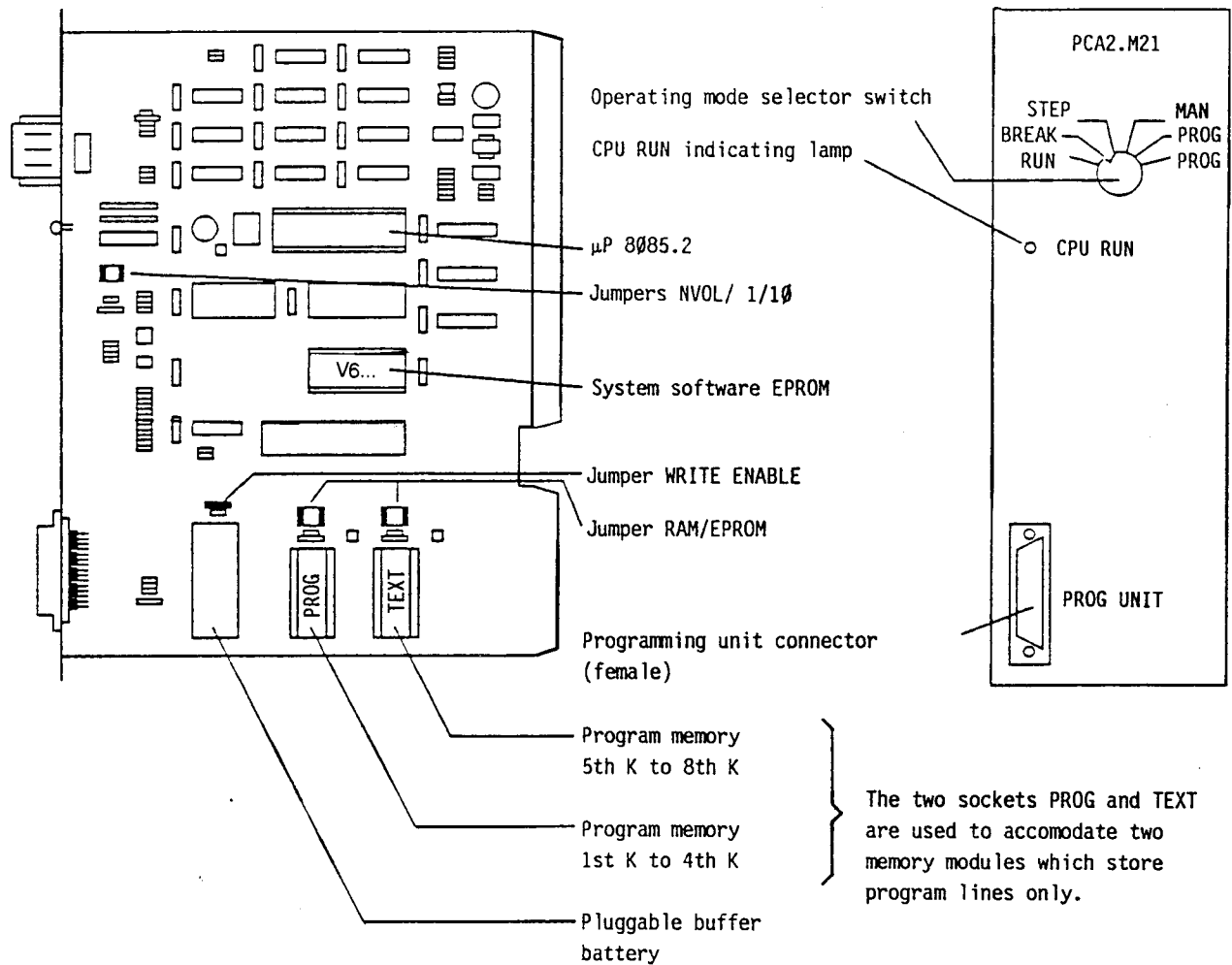

<sup>2)</sup> Please refer to the following text for modification possibilities.

Presentation



The two sockets PROG and TEXT are used to accommodate two memory modules which store program lines only.

Printed circuit board

- NVOL  When the jumper is inserted, all flags, timer and counter registers are non-volatile. When the jumper is not inserted (standard setting) only the flags 765...999 are non-volatile.
- 1/10  When the jumper is inserted (factory setting), the time base for the timers is 1/10s. Without the jumper being inserted, it is 1/100s.
- A  No function on the PCA2.M21.

WRITE  
ENABLE

When the jumper is not inserted, both locations are write-protected.

The write lead connection for the old buffered RAM-memories (e.g. R94) does not depend on this jumper.

RAM  
EPROM

Selection of the supply voltage for the user memory with the jumper inserted in:

RAM --> voltage supply by buffer battery of the processor module  
EPROM --> direct voltage supply

64K memories are recommended as memory modules:

- . buffered RAM-memory PCA1.R95/R96
- . RAM-chip 6264 or 8464 (order no. 4'502'4718'0)
- . EPROM 2764 (order no. 4'502'4719'0)

When using buffered RAM-memories, the selectable jumper must be inserted in EPROM, in order not to overburden the buffer battery.

Buffer  
battery

It supplies the registers (counters/timers, flags, data blocks), date-time and, if RAM-chips 6264 or 8464 are used, this user memory, too. Data remains stored for about 2 months after switching the PLC off.

Life expectancy of the NiCd-Accu is approximately 5 years (see sticker).

Spare part no. 4'507'1360'0.



## Front panel

The 25-pole connector serves to connect the programming unit (PGU). The PGU-connector is female and it is fitted with a sliding lock.

The "CPU RUN" indicating lamp blinks every 2s during normal operation of the CPU. If the time base is changed to 0.01s, the flashing cycle is 0.2s (5Hz). If the lamp remains in the same state (on or off), either the power unit was not switched on, the PLC is in RESET-mode, the CPU is defective or a trap has been produced in the software sequence.

The operating mode selector switch mainly serves for starting up and troubleshooting. If the programming unit is disconnected, the operating mode is always "RUN" independent of the position of the rotary switch.

The two PROG positions have the same function.

## Block circuit diagram

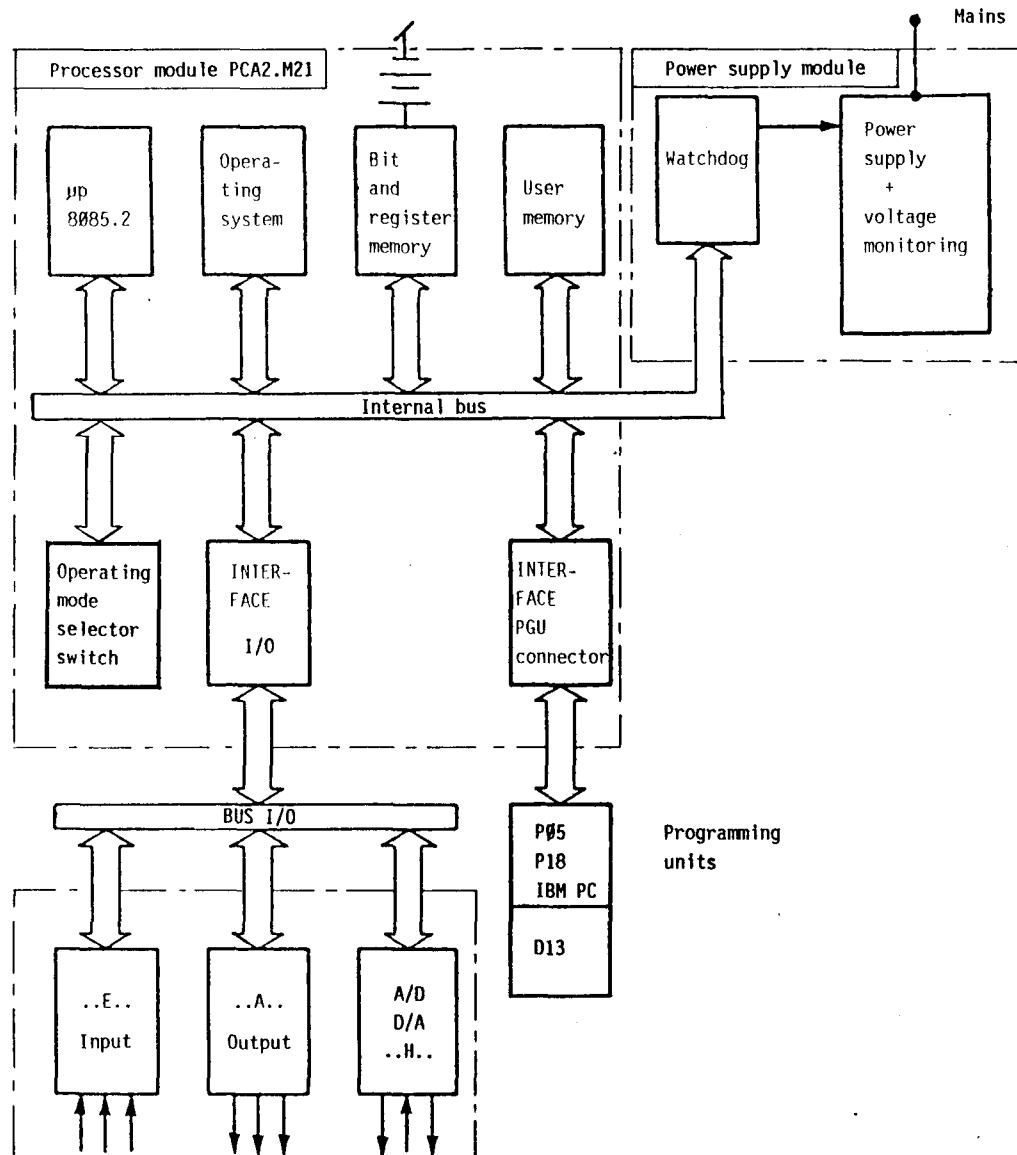

Register organisation

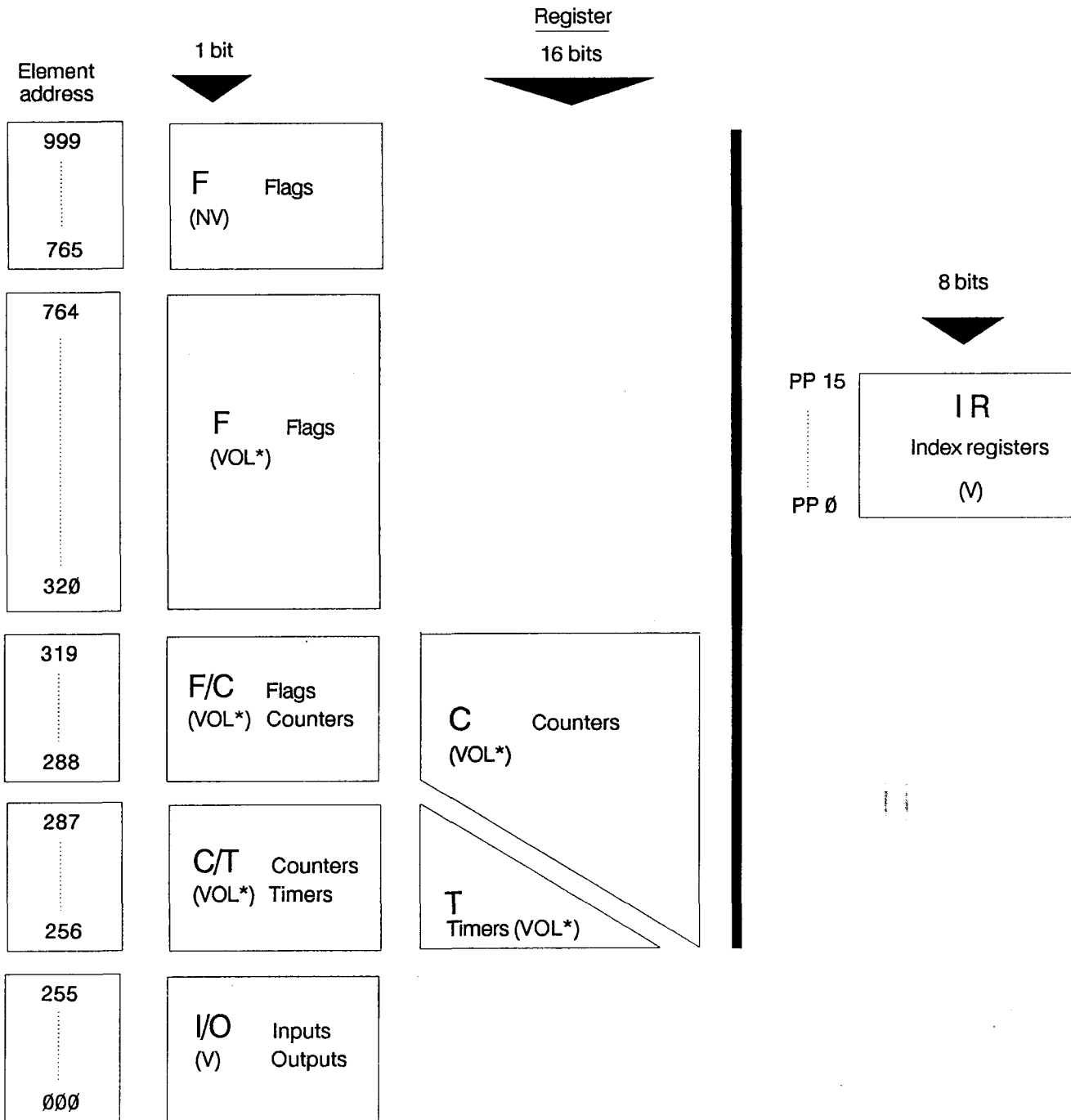

(V) volatile  
 (NV) non-volatile  
 (VOL\*) volatile, can be made non-volatile with jumper NVOL

User memory division on the sockets PROG and TEXT

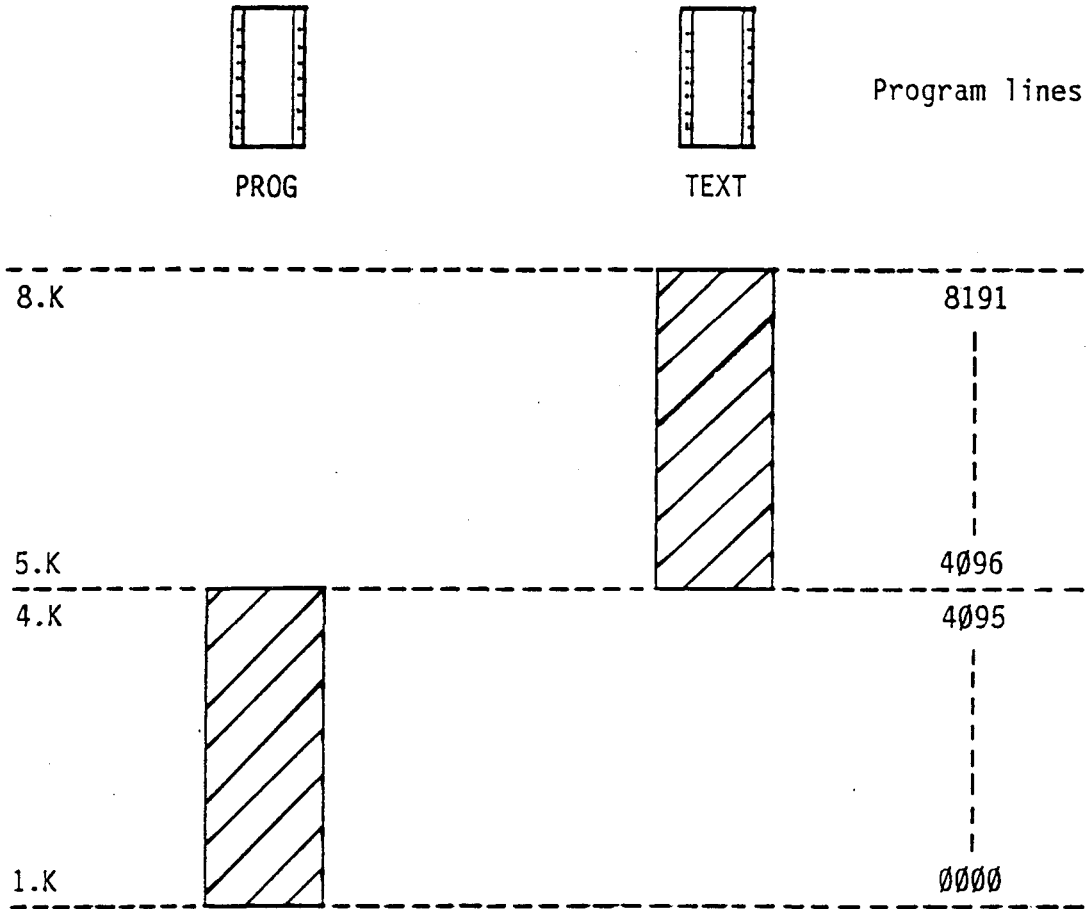

The sockets PROG and TEXT accommodate the memory modules (RAM or EPROM) in which only user programs are stored.

### A 3 PCA2.M22 Processor module (software level ②)

#### Technical data

CPU	μP 8085.2, system program V6.2.. 1)
Cycle time	70μs (per program line, logic instructions)
Instruction set	32 basic instructions, 20 additional instructions for arithmetic, text output, communication and parameter functions
Parameter functions	PID-loops, shift registers, check sum, interrupt management
Number of parallel programs	16 (PP 15 for interrupt control)
Number of index registers	16 (1 per parallel program, capacity of 255)
Number of subroutines	as desired, in max. 3 levels each
User memory (16 bits)	max. 8K program lines in EPROM, RAM or buffered RAM memory on two sockets
Text memory (8 bits)	max. 8K characters in EPROM, RAM or buffered RAM memory
Data memory (8 bits)	max. 8K characters in EPROM, RAM or buffered RAM memory
Inputs and outputs	256 or 512 (with extension housing 256 I + 256 O)
Flags	712 (477 volatile 2), 235 non-volatile)
No. of timers	32 (ADD 256...287)
No. of counters or arithmetic reg.	224 (ADD 256...479) as of V6.230
Counting cap. or arithmetic reg.	65'535 ( $2^{16}-1$ ) with cascading as desired
Time range	0.1 (0.01)s...6553 (655)s 2)
Date-time (hardware)	Week, day of the week, year, month, day, h, m, s
Accuracy of date-time	higher than 15s per month (details see module PCA2.R27)
Power reserve of date-time	2 months at 25°C (when user memories EPROM or R95/R96 are used)
Serial data interface	20mA current loop, active or passive, for input/output of text or communication acc. to DIN 66019, baud rate 110...9600 bauds 3)

1) When switching on the PLC, the system version is displayed on the programming unit P10 or P05 for about one second. For this reason, the operating mode selector switch must be in position RUN.



2) Please refer to the following text for modification possibilities.

3) High baud rates require an appropriate program structure.

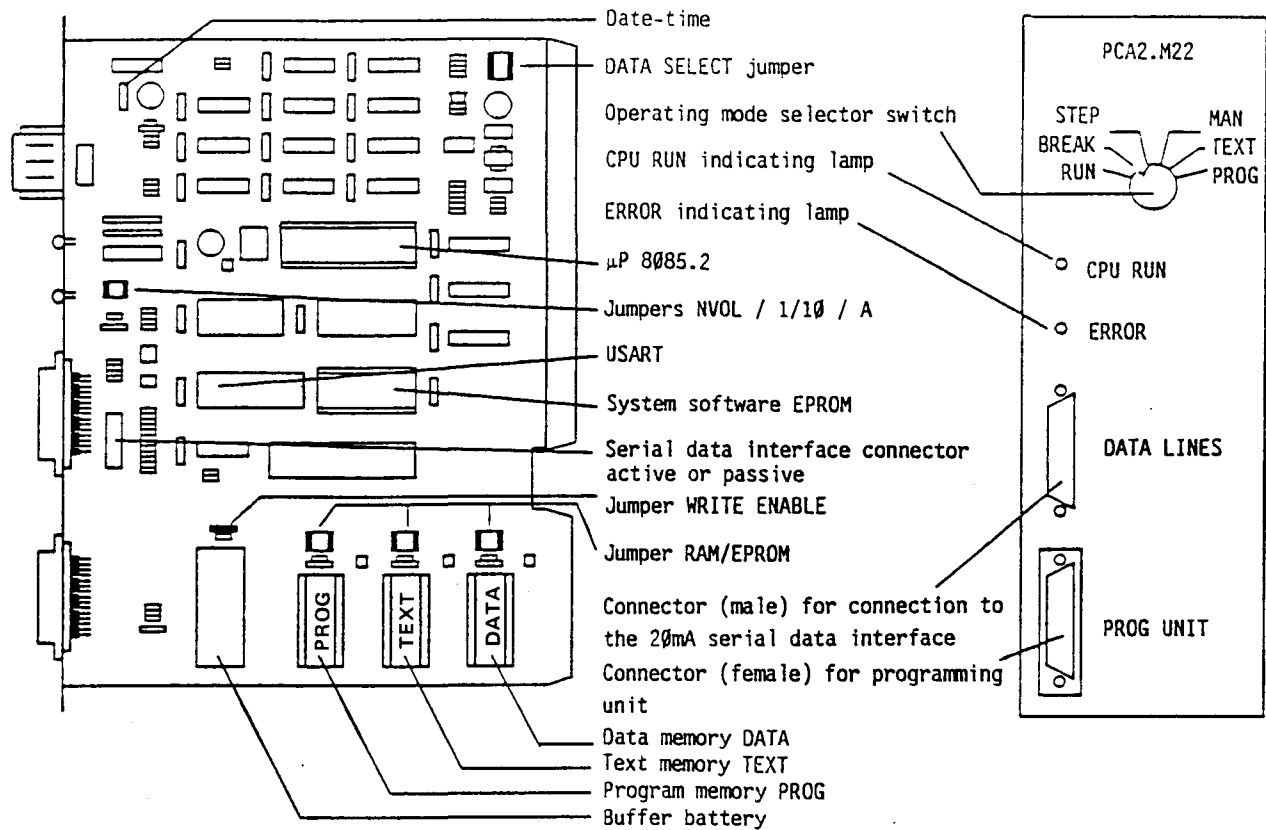
## Presentation



## Printed circuit board

- NVOL**  When the jumper is inserted, all flags, timer and counter registers are non-volatile. When the jumper is not inserted (standard setting) only the flags 765...999 are non-volatile.
- 1/10**  When the jumper is inserted (factory setting), the time base for the timers is 1/10s. Without the jumper being inserted, it is 1/100s.
- A**  When the jumper is inserted, all 32 data blocks (PID) are volatile (factory setting).

## DATA-SEL



The total storage space available for text and data memory together amounts to max. 8K bytes (8K characters).

Memory areas can be assigned to the DATA socket by inserting the jumpers.

The TEXT socket as well as the DATA socket can be used to accommodate RAM- or EPROM-memories for the user program in the range 4096...8191.

Arrangement of the sockets and memory areas see chapter "User memory division".

WRITE  
ENABLE

If a RAM is used on sockets PROG and TEXT, the write lines need to be connected separately by inserting the jumper.

When the jumper is not inserted, write-protection is provided on both sockets.

The DATA socket is not write-protected.

Write lead connection for the old buffered RAM-memories (e.g. R94) does not depend on this jumper.

RAM  
EPROM

Selection of the supply voltage for the user memory with the jumper inserted on:

RAM ---> voltage supply by buffer battery

EPROM ---> direct voltage supply

64K memories (8K bytes) are recommended as memory modules:

- . buffered RAM-memory PCA1.R95/R96
- . RAM-chip 6264 or 8464 (order no. 4'502'4718'0)
- . EPROM 2764 (order no. 4'502'4719'0)

When using buffered RAM-memories, the selectable jumper must be inserted in EPROM, in order not to overburden the buffer battery.

Buffer  
battery

It supplies the registers (counters/timers, flags, data blocks), date-time and, if RAM-chips 6264 or 8464 are used, this user memory, too. Data remains stored for about 2 months with the PLC switched off.

Life expectancy of the NiCd-Accu is approximately 5 years (see sticker).

Spare part no. 4'507'1360'0.

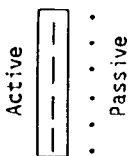
Serial  
data  
interface

Depending on the connector position the serial data interface (20mA-current loop) can be programmed as follows:

ACTIVE --> active current loop (20mA for transmitter and receiver are supplied by M22)

PASSIVE --> passive current loop (20mA for transmitter and receiver must be supplied externally)

## Front panel

The lower connector of the two 25-pole connectors (PGU) serves to connect the programming unit. It is fitted with a sliding lock for fixing the cable connector.

The upper connector (DATA LINES) is used to connect a peripheral unit. The cable connector is fastened with screws.

In order not to confuse the two connectors, the PGU-connector is female and the DATA LINES connector is male. (details see M32)

The "CPU-RUN" indicating lamp blinks every 2s during normal operation of the CPU. If the time base is changed to  $0.01s$ , the flashing cycle is  $0.2s$  (5 Hz). If the lamp remains in the same state (on or off), either the power unit was not switched on, the PLC is in RESET-mode, the CPU is defective or a trap has been produced in the software sequence.

The "ERROR" indicating lamp indicates transmission errors in the serial data line.

The operating mode selector switch mainly serves for starting up and troubleshooting. When the programming unit is disconnected, the operating mode is always "RUN" independent of the position of the rotary switch.

## Block circuit diagram

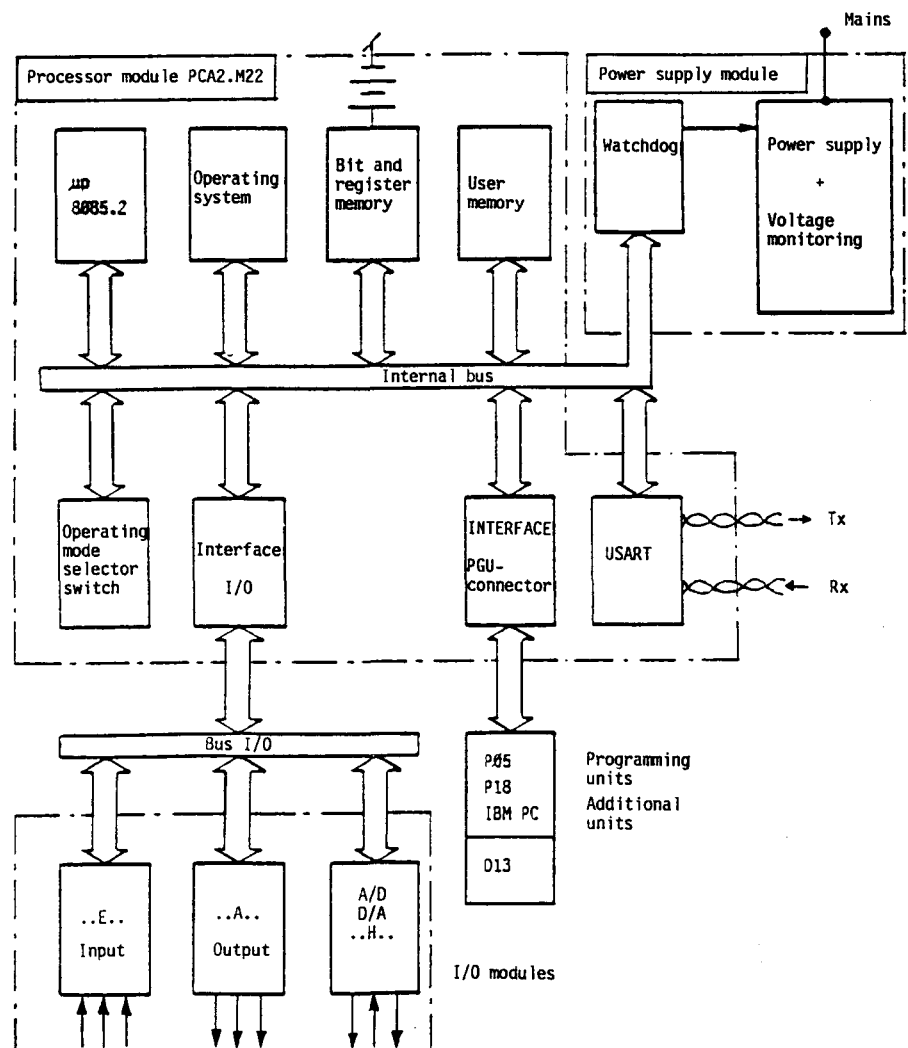

Register organisation

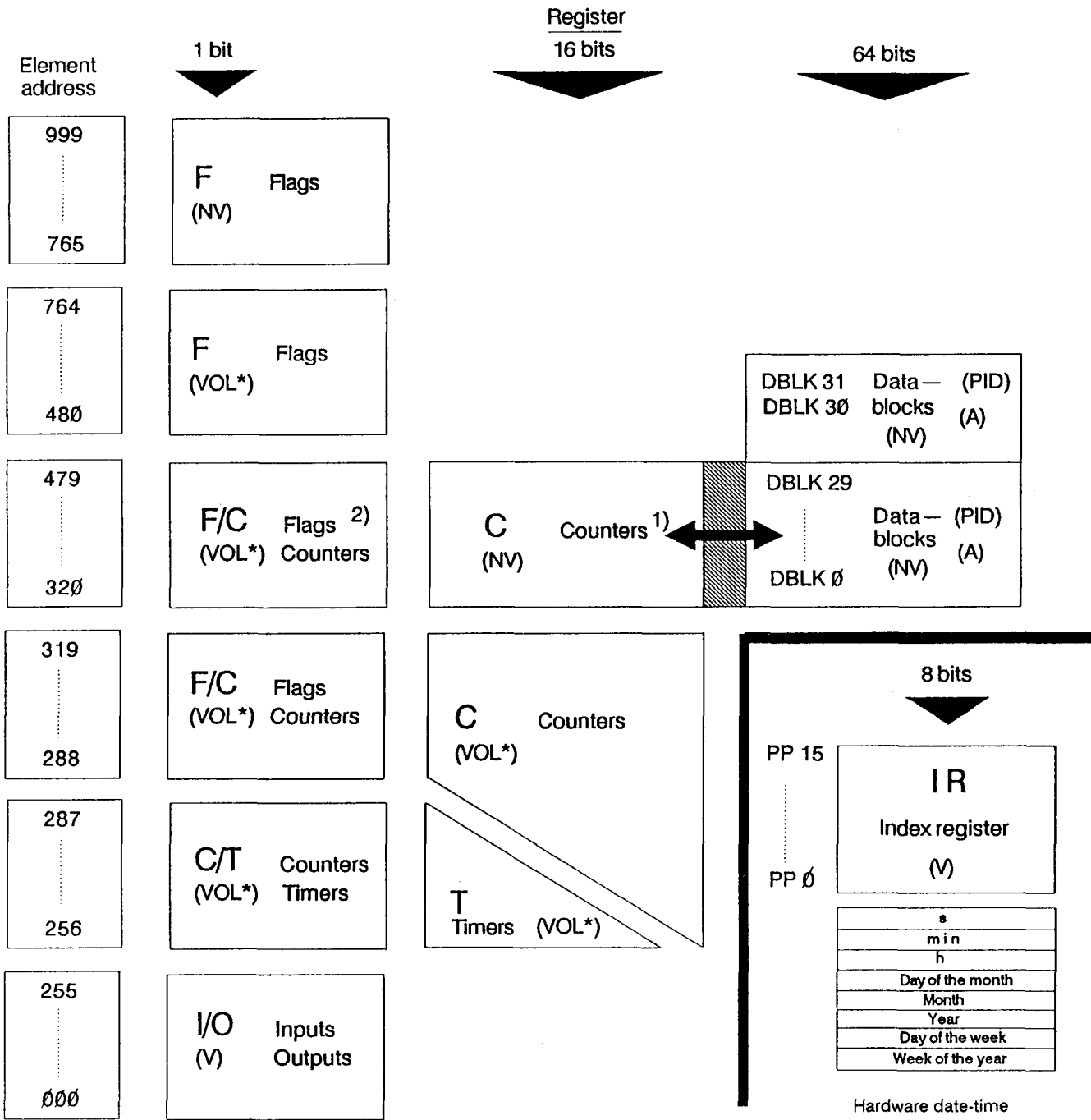

- (V) volatile
- (NV) non-volatile
- (VOL\*) volatile, can be made non-volatile with jumper NVOL
- (A) jumper A open: all 32 DBLK are non-volatile

- 1) Counter registers C320...C479 and PID-data blocks 0...29 use the same memory area. It is therefore recommended to start with DBLK 31 for PID-control tasks.
- 2) The counter registers C320...C479 are available from system program version V6.230 onwards.



User memory division on the sockets PROG, TEXT, DATA

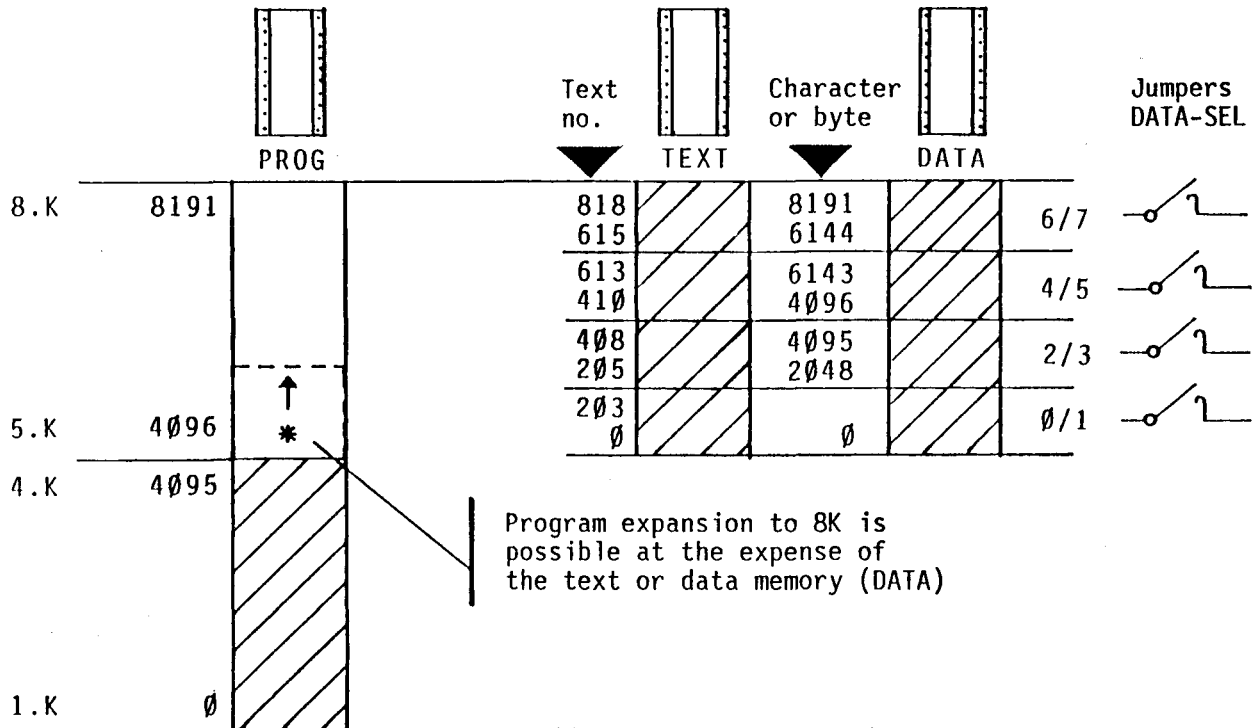

Example

The memory must be subdivided as follows:

- 5K program lines in EPROM (socket PROG+TEXT) (≅ 5K program lines)
- 4K text characters in EPROM (socket TEXT) (≅ 2K program lines)
- 2K byte data in RAM (socket DATA) (≅ 1K program line)

Total 8K program lines

EPROM 2764 are plugged onto sockets PROG and TEXT. A RAM-chip 6264 or a buffered RAM-module PCA1.R95 or R96 is plugged onto socket DATA.

Jumpers "RAM/EPROM" above the sockets must be inserted accordingly.

- The program uses program lines from 0...5119 (5K).
- The lowest text address is 205 (char. (2048:10)+1)
- The highest text address is 613 (char. (6143:10)-1)
- For the data area (in RAM) ranging from 6144...8191 (2K bytes) the DATA-SEL jumper 6/7 is inserted.

#### A 4 PCA2.M32 Processor module (software level ③)

##### Technical data

CPU	16 bit $\mu$ P, type 68000, with system program V7.1XX <sup>1)</sup>				
Cycle time	35 $\mu$ s per program line (logic instructions)				
Instruction set	32 bit instructions plus extension (arithmetic, text output, communication and parameter instructions) plus 32 word instructions				
Number of parallel programs	16 (PP15 for interrupt control)				
Number of index registers	16 (1 per parallel program)				
Capacity of index registers	1023 (1K)				
Number of subroutines	as desired, in max. 3 levels each				
User memory	<table> <tr> <td>8K program steps</td> <td rowspan="3">} in RAM or EPROM with memory modules PCA2.R26/R27</td> </tr> <tr> <td>+8K ASCII character text memory</td> </tr> <tr> <td>+8K byte data memory</td> </tr> </table>	8K program steps	} in RAM or EPROM with memory modules PCA2.R26/R27	+8K ASCII character text memory	+8K byte data memory
8K program steps	} in RAM or EPROM with memory modules PCA2.R26/R27				
+8K ASCII character text memory					
+8K byte data memory					
Input plus output addresses	256 (256 I + 256 O = max. 512 I/O with extension housing)				
Software timers plus counters or arithmetic registers	256 (ADD 256...511) (ADD 256...287 timers/counters) (ADD 288...511 counters or arithmetic registers)				
Counting capacity	65'535 ( $2^{16}-1$ )				
Time range	0.1 (0.01)s...6553 (655)s <sup>2)</sup>				
Non-retentive and retentive flags	477/235 * (ADR 288...999)				
Word register	1K byte (ADD 0...999) non-volatile				
Date-time, software	week of the year, day of the week, year, month, day, h, min, s (without power reserve)				
Date-time, hardware (R27)	week of the year, day of the week, year, month, day, h, min, s (with power reserve)				
Serial interface	20mA current loop (active or passive)				
Copying possibilities of user memory	RAM/EPROM/EPROM/RAM/RAM with comparison of contents				

1) Upon switching on the PLC, the system version is displayed on the P10 or P05 programming unit for approx. 1 second (operating mode selector switch in position RUN).

2) For possibilities of modification refer to the following text.

## Presentation

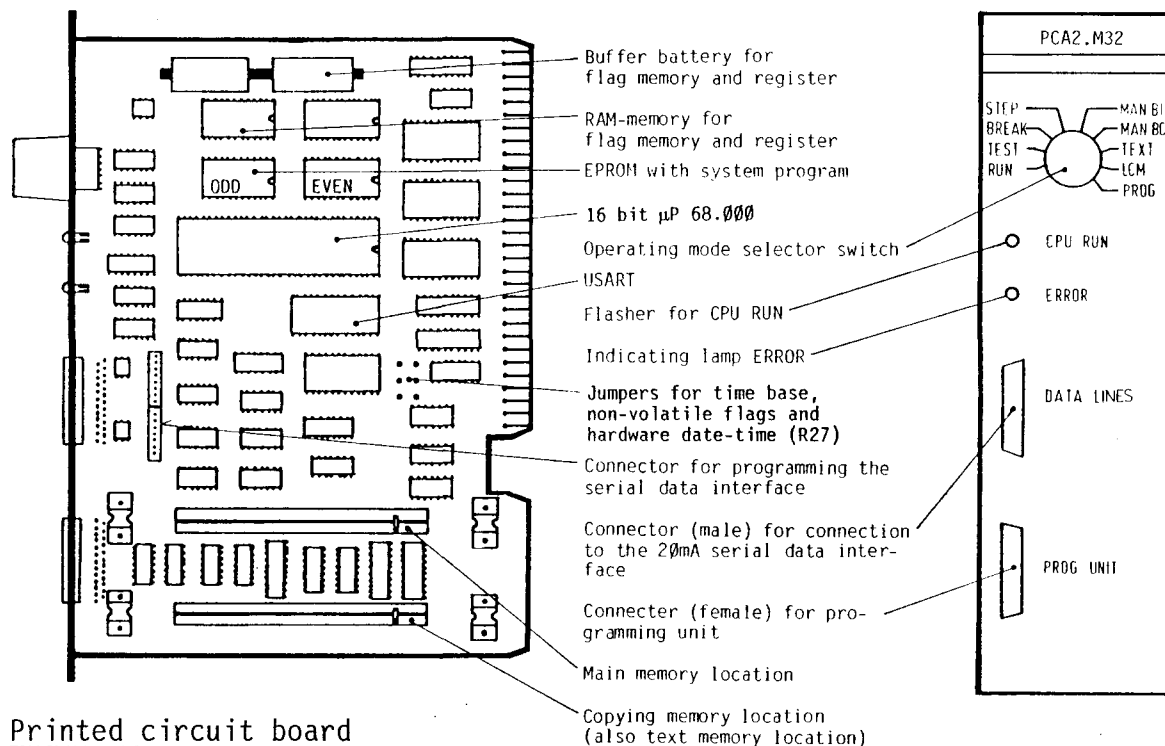

## Printed circuit board

The pc-board accommodates all active parts of the CPU. Various properties of the CPU may be modified by reinserting jumpers or plugging connectors into different sockets:

- 1/10  With the jumper inserted (as delivered) the time base is 1/10s. With the jumper not inserted the time base is 1/100s.
- VOL  With the jumper inserted (as delivered) the distribution of the non-retentive flags is as follows:  
 288...764 non-retentive flags, volatile  
 765...999 flags, non-volatile  
 256...511 timer and counter register, volatile  
 When the jumper is not inserted, all memory addresses from 256...999 are non-volatile flags resp. timer and counter registers.
- R27  With the jumper inserted the hardware date-time on module PCA2.R27 is recognized as master. R27 must be on the main memory socket. When the jumper is not inserted, the software date-time of the CPU system quartz is recognized as master (without power reserve).

Attention : if any other memory module than R27 or R29 is on the main memory socket and the jumper R27 is inserted, the step adress 0 can be falsified in the case of RAMs.

## Programming of the serial interface (active or passive)

- Connector in the upper half results in a passive 20mA current loop (20mA for transmitter and receiver must be supplied by an external power source).
- Connector in the lower half results in an active current loop (20mA for transmitter and receiver are supplied by the M32).

The buffer battery (NiCd accumulator) supplies all elements defined as non-volatile (such as flags, counters, timers, word registers and data blocks) with power. Data remains stored for about 2 months. Life expectancy is approximately 5 years (see red sticker).  
Spare part no. 4'507'1195'0.

### Front panel

The lower connector of the two 25-pole connectors (PGU) serves to connect the programming unit. It is fitted with a sliding lock for fixing the cable connector.

The upper connector (DATA LINES) is used to connect a peripheral unit. The cable connector is fastened with screws.

In order not to mix the two connectors, the PGU-connector is female and the DATA LINES connector is male.

The indicating lamp "CPU RUN" flashes every 2s during normal operation of the CPU. If the time base is changed to 0.01s, the flashing pulse is 0.2s (5 Hz). If the lamp remains ON or OFF, either the power supply unit was not switched on, the PLC is in reset position, the CPU is defective or a trap has been produced in the software sequence.

The indicating lamp "ERROR" indicates errors occurring along the serial data line.

The operating mode selector switch mainly serves for starting up and troubleshooting. When the programming unit is not connected, the operating mode "RUN" is always selected irrespective of the rotary switch position.

Serial interface connection (only valid for PCA2.M22 and M32)

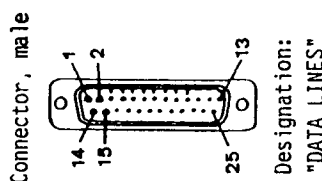

25-pole D-sub connector  
with locking screws

For PCA2.M22 and M32, the interface can be made "active" or "passive" and thus adapted to the peripheral unit by repositioning a multi-way connector.

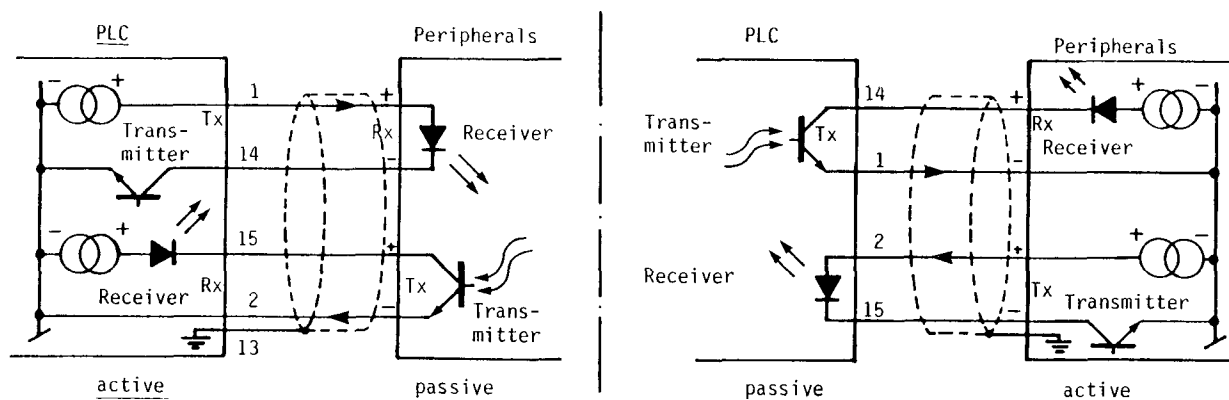

Block circuit diagram of the CPU PCA2.M32

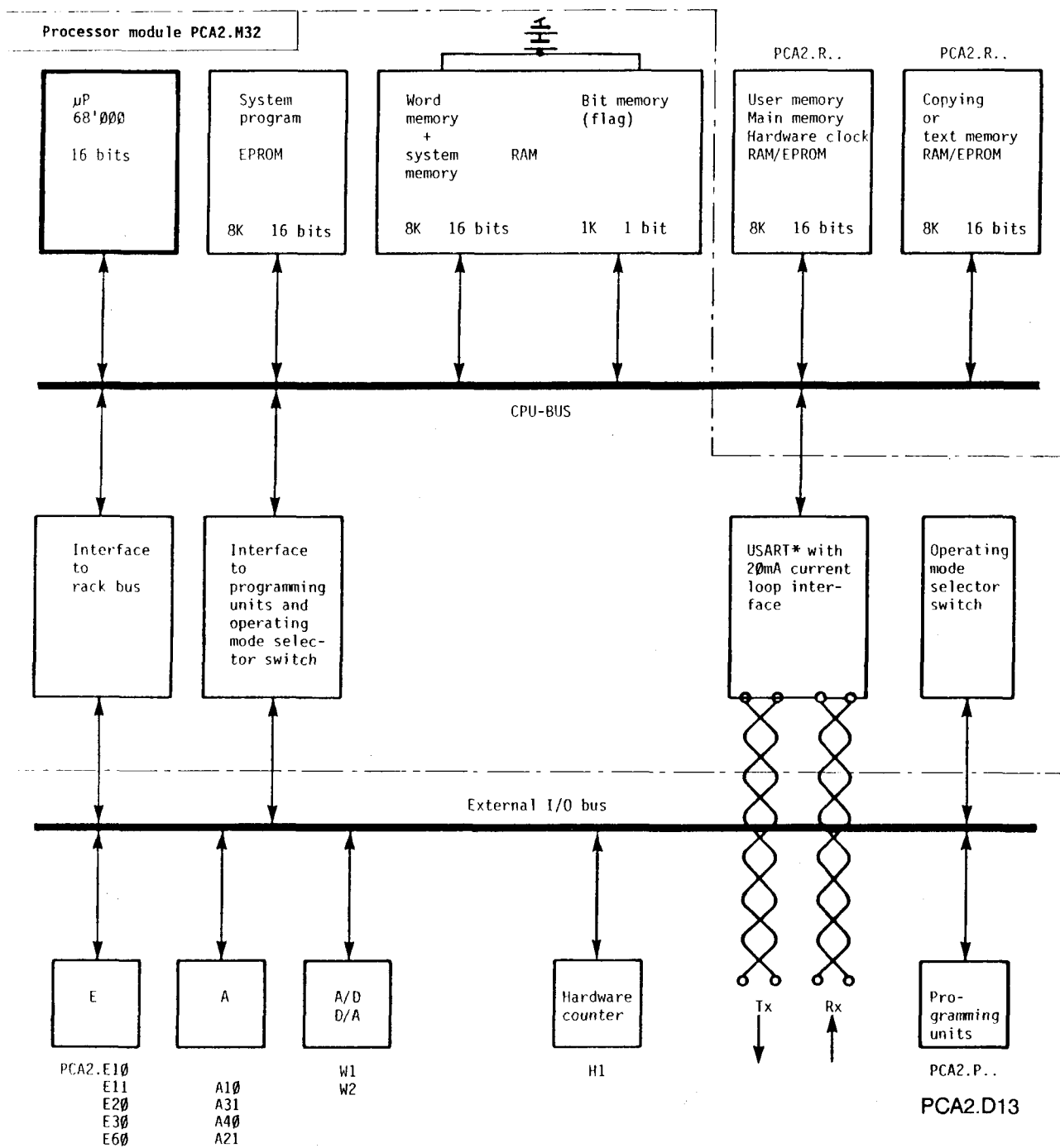

\*) USART = Universal Synchronous/Asynchronous Receiver Transmitter

### Organisation of the bit and word registers

Apart from the registers of the bit processor, the CPU PCA2.M32 comprises also a large word register to which the word processor has access.

#### Registers of the bit processor:

These three registers are upwards-compatible among the other SAIA<sup>®</sup>PLC of the series PCA1 and PCA2. The extended bit processor instruction set of the CPU M32, however, allows a much more extensive data exchange.

Apart from the non-volatile flags (765...999) all registers of the bit processor are volatile. All flags and counter registers can be made non-volatile by removing a jumper (see "Printed circuit board").

- Bit register En  
All logic states of all elements (except inputs) are stored in here. Addressing can be effected from 0...999.
- Counter register Cn  
Via the element addresses 256...511, the bit processor instruction set allows access to the counter resp. timer register of 256 x 16 bits (= 256 x 65'535). The memory is organised in binary format. The instruction set, however, allows inputs and outputs converted into decimal values resp. BCD-format.
- Index register IR (address indexing see software)  
The 16 registers are automatically selected via assignment of the respective parallel program. The number of 10 bits allows input and output of decimal values from 0...1023.

#### Register of the word processor:

The entire word register is non-volatile. Rn words of 8 bit can be addressed from 0...999. Additional commands also allow simultaneous processing of register blocks of 5 x 8 bits.

Basically, it is a register for BCD-coded values, since all arithmetic operations, preceding signs (+/-) included, are based on BCD-format. Purely binary words, however, can also be transferred and stored.

The registers 0...20 are reserved for special functions. It is recommended not to use addresses below R50 or R100 for general purposes.

R0...R14 are referred to as arithmetic registers, because the arithmetic operations are performed between the register blocks A0...A2. R4 for 2-digit and A0 for 9-digit decimal numbers plus preceding signs (+/-) take precedence. The significance of the positions is evident from the following figure.

The data of the internal software date-time is stored in R15 to R19. From R20 to Rn an 8-bit shift register can be created.

#### Data block register:

It serves for storing the parameters for the 32 PID-control loops and is operated with the instructions PAS 200...212.

Overview of the registers of CPU PCA2.M32

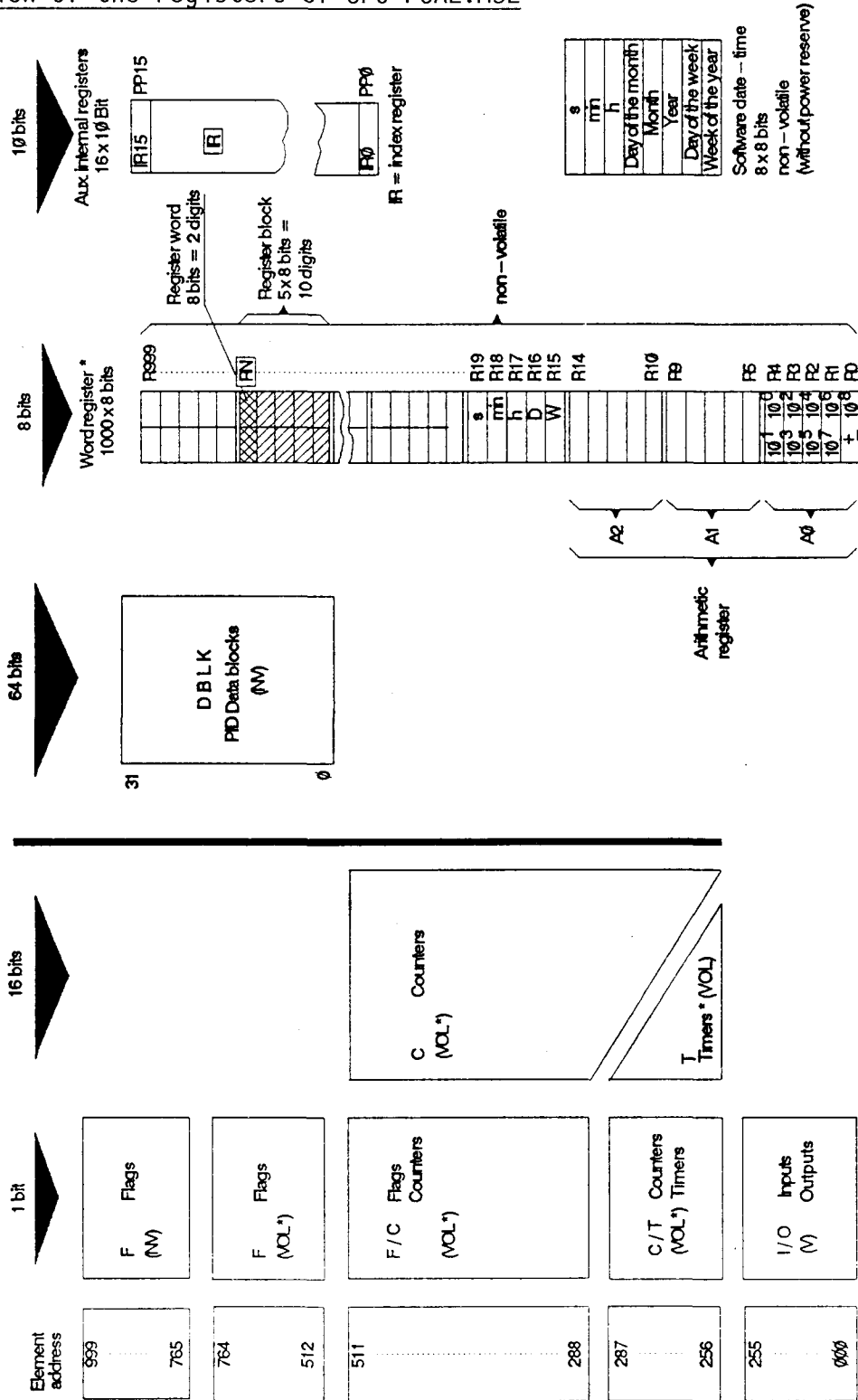

(V) volatile  
 (NV) non-volatile  
 (VOL\*) volatile can be made non-volatile with jumper NVOL

\*) The user memory may also be used as an additional data memory (8K x 8 bits).

### Organisation of the user memory

All RAM- or EPROM-modules, except R11/R12, can be used for storing user programs as well as texts and data. The full storage capacity, however, is only obtained, if memory modules PCA2.R26/R27 are used.

The upper plug-in location (main memory location) of the CPU is used for user programs in the address range  $\emptyset \dots 8K$  program steps. Module R29 with hardware date-time is also used on this socket.

The lower plug-in location can be used for texts or data. The text memory capacity is 8K ASCII-characters, the data memory capacity is 8K times 8 bits.

The detailed organisation of the user memory regarding user programs, texts and data is evident from the following figure.

All programs resp. texts are programmed and read in the plug-in location assigned to them. Only copying to RAM or EPROM is always effected from the upper to the lower socket. If, for example, programs of more than 4K or texts are to be copied, the master card is attached at the top. Copying is effected word by word from the upper socket to the lower socket, irrespective of the contents of the memory card.



## Overview of the user memory

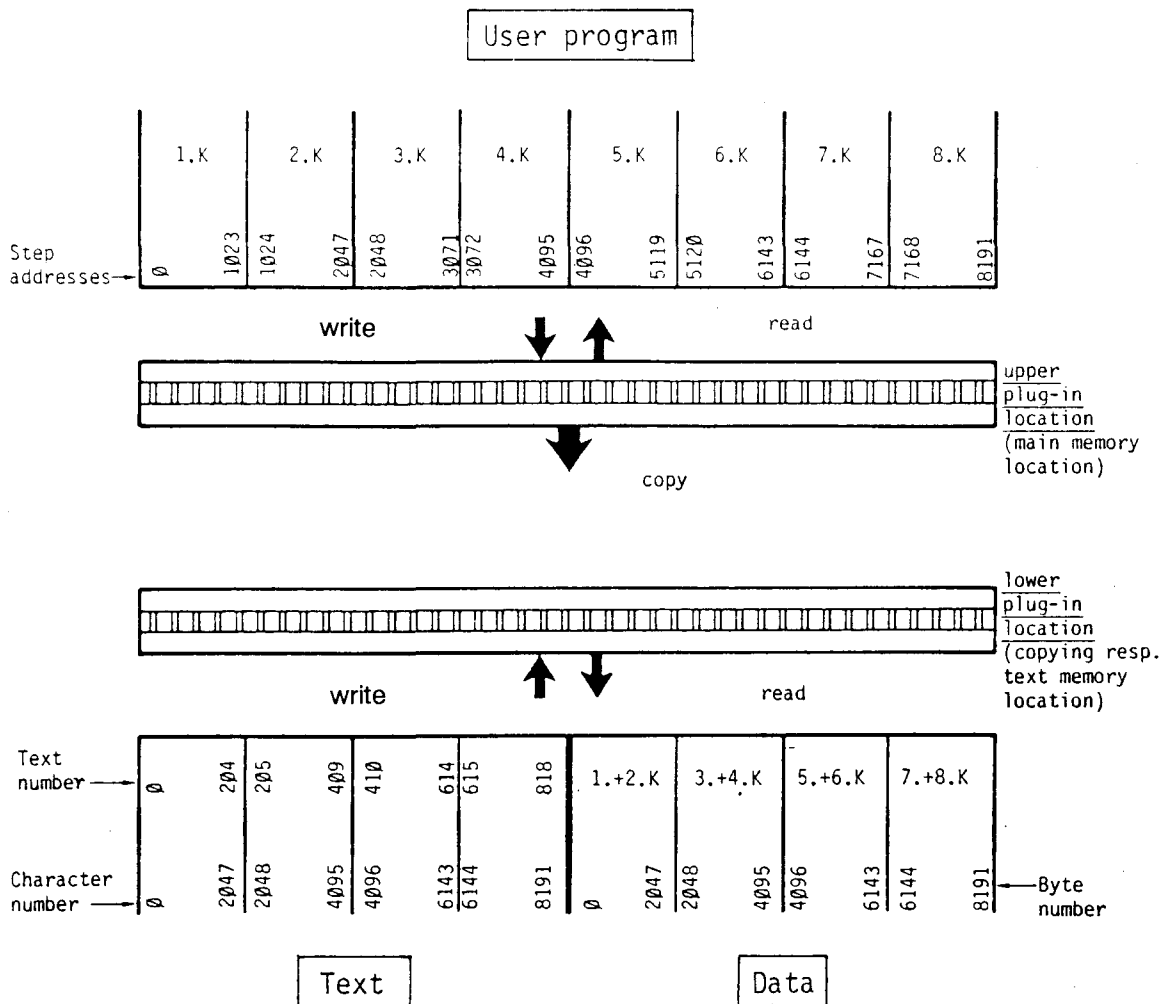

The step addresses from the 5th K to the 8th K of the user program as well as the entire data memory of 8K bytes can be made full use of only with the memory modules PCA2.R26/R27, as the storage capacity of all other R-modules amounts to max. 4K step addresses.

If the 8K step addresses for the user program or the 8K characters for the texts are not sufficient for your application, please ask for our special documentation on possibilities of expansion.

User memory division into program, text and data

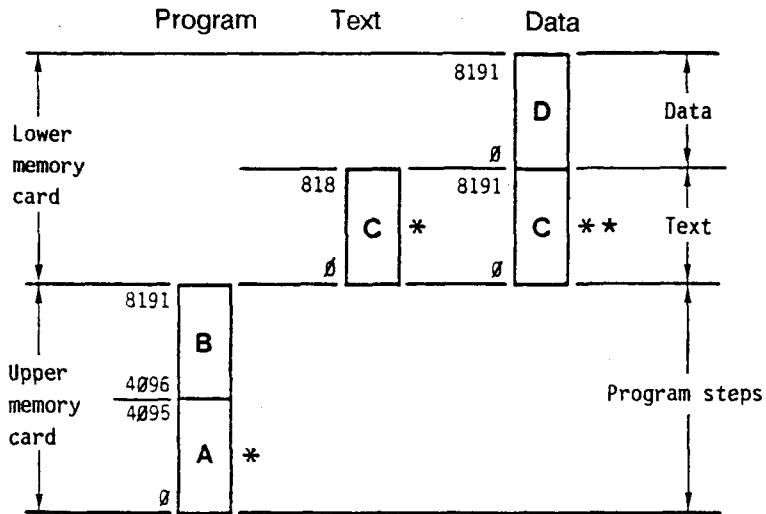
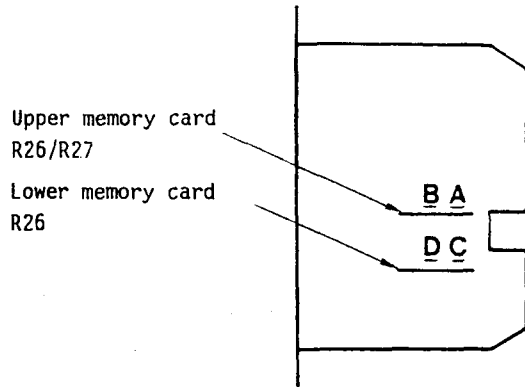

\*) A and C are address ranges for old memory modules with 4K user memory.  
 \*\*) Text memory which may also be used as data register with PAS 54/55.

## A 5 User memory modules

Type PCA2.R26 Memory module

Type PCA2.R27 Memory module with buffered date-time (clock module)

With the memory module R26 the EPROMs 2764, the buffered RAM-module PCA2.R95 or R96 as well as the RAM types 6264 and 8464 can be programmed and read. Two of these memories can be plugged onto the module, which results in a capacity of 8K program steps.

As memory module ..R27 is identical to ..R26. The date-time incorporated in addition permits precise output of second, minute, hour, day of the month, year, day of the week, week of the year. Deviation is less than 15s per month and the power reserve exceeds 2 months. As a result, exact time switch functions as well as event or alarm loggings with date and time can be realised.

This buffered date-time module can only be evaluated with CPU PCA2.M32 on the upper socket.

### Presentation

The following figure shows the clock module PCA2.R27. Next to the two memory sockets is the date-time.

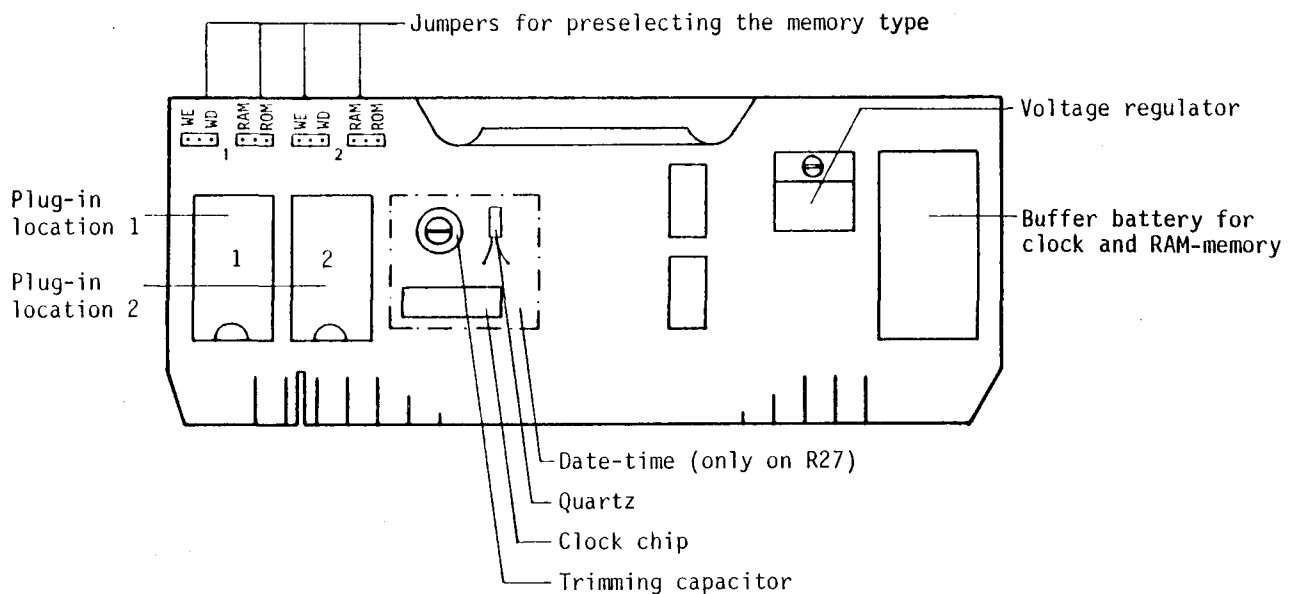

The clock and any RAMs have a power reserve of more than 2 months.

### Preselection of the memory type

Two jumpers are provided for each socket allowing preselection of the user memory.

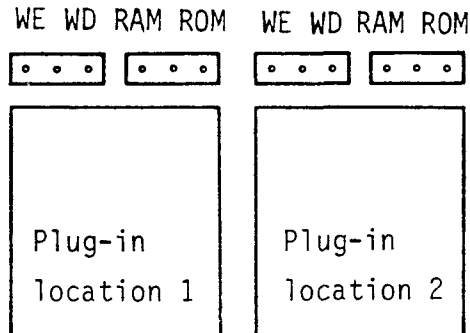

The jumpers on the right RAM/ROM serve to preselect the memory type.

	RAM	ROM	
EPROM 2764	:		} The connection with the buffer battery is interrupted
PCA1.R95/R96	:		
RAM 6264, 8464	:		The RAM is buffered by the battery

The jumpers on the left WE/WD serve to determine whether the memories RAM 6264, 8464 and the buffered RAM-module PCA1.R95/R96 are write-protected or not.

	WE	WD	
Write Enable	:		Overwriting is possible (not write-protected)
Write Disable	:		Overwriting is impossible (write-protected)

When copying EPROMs or RAMs (operating mode LCM) the jumper must be in position WE.

This structure has the following advantages:

- The user program can be divided as follows: e.g. 4K stored in an EPROM and 4K in a RAM.
- The texts of at most 8K ASCII-characters can be stored e.g. in an EPROM, while data (8K bytes) can be stored in a RAM.
- Each socket can be write-protected individually.

### Buffer battery

In case of voltage failure, or when the memory module is removed, the buffer battery supplies the RAM user memories (6264 or 8464) and the date-time on module R27.

Data is buffered for approx. 2 months and it has a life expectancy of 5 years. Spare part no. 4'507'1360'0.

### Data and operation of clock module R27

Access to the date-time is possible only via CPU PCA2.M32 (jumper "R27"). Thus, the following functions are possible:

- Setting the clock via user program (see PAS 50) or via programming unit (see C2.2).
- Output of time and/or date for logging purposes.
- Switching functions depending on date and time.

Every second the system program of the PCA2.M32 automatically transmits the contents of the date-time to the CPU. Via the user program the contents can be read out or adjusted (see PAS 50) at any time.

- Power reserve > 2 months
- Deviation < 15 s / month (15...30°C)
- Clock values
 

Week of the year	01...53	2)	4)	
Day of the week	01...07	2)	3)	
Year	00...99			
Month	01...12			
Day of the month	01...28, 29, 30, 31			1)
Hours	00...23			
Minutes	00...59			
Seconds	00...59			

1) The date-time takes the various months and leap years into account.

2) When setting the clock it must be ensured that day and month resp. day of the week and week match. The clock does not automatically make any corrections.

3) Day of the week 01 stands for Monday, 07 stands for Sunday.

4) According to the ISO-standards the first week of the year is represented by "01", if January 1st is a Monday, Tuesday or Wednesday. When a new year starts, the week number has to be checked accordingly.

## A 6 Power supply modules

### A 6.1 Type PCA2.N20/N21 Power supply module for 24VDC with integrated voltage monitoring and watchdog

#### Technical data

Supply voltage $V_{in}$	24VDC (smoothed or pulsating)
Voltage tolerance	-20% / +25%
Power consumption (24 VDC)	max. 2.5A (N20) resp. 3.5A (N21)
Input circuit fuse	2.5A slow-blow (N20) resp. 4A slow-blow (N21)
Output voltage $V_{aout}$ (electronics)	5V stabilised ( $\pm 3\%$ )
Output current 5V	max. 4A (N20) resp. 6A (N21)
Aux. output voltage $V_{aout}$ (EPROM)	Input voltage - 2V (at 1A)
Output current 24V ( $I_{aout}$ )	max. 1A
Watchdog frequency	$\geq 5\text{Hz}$
Watchdog contact	max. 0.5A, 48VAC or VDC
Supply terminal protection	IP 20 or IP 30 (with terminal lid which is supplied with every extension housing)

#### Presentation

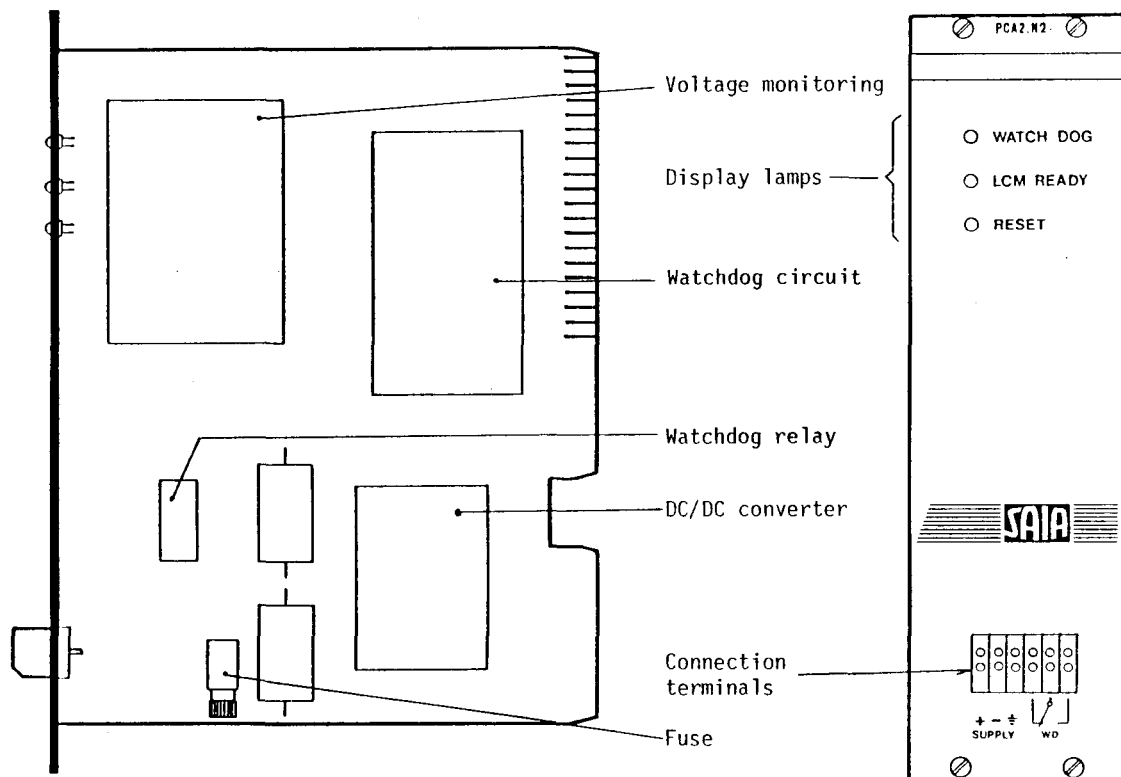

#### Description

Module PCA2.N20 supplies a stabilised 5V for supplying the electronics unit and a non-stabilised 24V for the internal driving of the output circuits and the LCM function (only for PCA2.M32). The supply module output circuits are galvanically connected to the input.

An input filter is fitted to provide effective suppression of interference voltages from the 24VDC supply. Good earthing at the terminal enhances the efficiency of this protective element.

The correct function of the mains unit is monitored by several circuits and the relevant states are displayed on the front panel.

- The red lamp **RESET** lights up when the input voltage is much too low or when the 5V for the electronics is incorrect. In both cases, the processor is stopped, all elements reset (with the exception of retentive memories), and the watchdog relay is released.
- The yellow lamp **LCM READY** lights up, when the auxiliary voltage  $V_{aout} = 24V$  to  $26V$  ( $V_{in} = 26V$  to  $28V$ ). The LCM lamp must also light up, if EPROMs 2716 are to be copied. For programming large-scale integrated EPROMs (2732A or 2764) which require a voltage tolerance of only  $\pm 0.5V$ , module N30/N31 must be used.
- The yellow lamp **WATCHDOG** indicates that the watchdog relay is energised. This is the case when the watchdog circuit is activated in a cycle of  $\leq 0.1s$  by complementation of PLC address "255". The required instruction in the user program is "COO 255" which is programmed at the beginning of a circulating main or parallel program. The watchdog circuit thus reliably monitors continuous processing of the user program.

If the PLC normally processes all programs in the operating mode "RUN", the watchdog relay remains energised; in any other mode or in the event of a fault in the CPU or the supply, the relay is released. The watchdog relay is also released when the mode switch is moved from the operating mode "RUN", and the programming unit is plugged in. Appropriate safety measures can be taken using the available two-way contact.

### Block circuit diagram

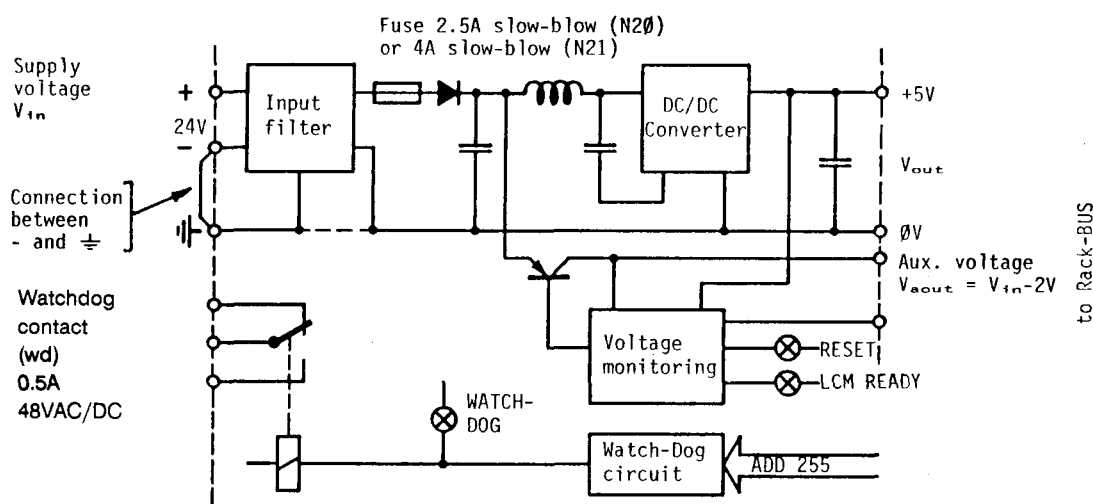

## A 6.2 Type PCA2.N30/N31 Power supply module for alternating voltage with a built-in voltage monitoring system and watchdog

### Technical data

Mains voltage $V_{in}$	220V, 50 - 60Hz, type D4 240V, 50 - 60Hz, type D6 110V, 50 - 60Hz, type C8
Voltage tolerance	-15% / +10%
Power consumption	80VA (N30) resp. 120VA (N31)
Fuses	see below
Output voltage (electronics)	+5V stabilized
Output current 5V	max. <u>4A (N30)</u> resp. max. <u>8A (N31)</u>
Output voltage (EPROM)	+25V stabilized ( $\pm 1\%$ )
Output current 25V	max. $\emptyset.4A$ (N30 and N31)
Watchdog frequency	$\geq 5Hz$
Watchdog output contact	max. $\emptyset.5A$ , 48VAC/VDC
External reset input	By repositioning a jumper from WD to R
Protection of the supply terminals	IP 20 resp. IP 30 (with terminal lid which is supplied with every rack unit)

### Presentation

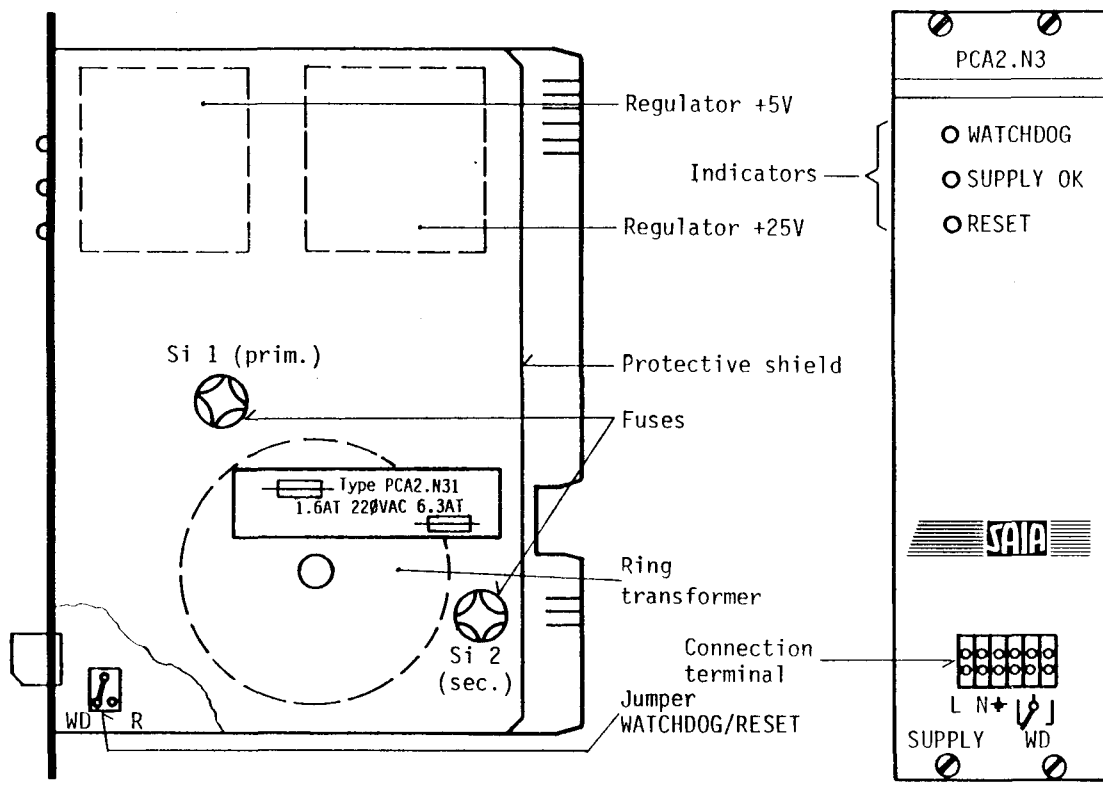



### Structure

The modules N30/N31 are mounted on 2 plates. The heavy transformer is mounted on the iron shield, the electronic system with the regulators is on the printed circuit board. Thus, not only good heat dissipation is achieved, but also protection against shocks, as the iron shield is additionally supported in two guideways. When transporting a PCA2, the power supply module must be removed from its plug-in location and packaged separately.

### Fuses (cartridges 5 x 20 mm)

Mains (220V): Si 1: 1.6A slow-blow (N30), 1.6A slow-blow (N31)  
 Secondary : Si 2: 4A slow-blow (N30), 6.3A slow-blow (N31)

Easy access to the fuses on the shield is provided by removing the module.

### Description

The power supply module meets the internal power requirements of the PCA2. The input and output circuits are supplied by an external power supply unit operated by the user. For the PLC-modules a simple single-phase transformer with bridge rectifier is sufficient.

The power supply module provides two stabilized voltages:

- + 5V for the power requirements of the electronics
- +25V for programming the EPROMs and for the internal activation of the output circuits.

Proper functioning of the mains unit is supervised by several circuits and the respective states are displayed on the front panel:

- The red lamp RESET lights up, if the mains voltage  $V_{in}$  is much too low or if the 5V-voltage falls below 4.7V. In both cases, the processor is stopped, all outputs are reset and the watchdog relay is released. The same reset is effected when the RESET-input is connected to ground (0V).
- The yellow watchdog lamp indicates that the watchdog relay is excited. This is the case when the watchdog circuit is activated in a cycle of  $\leq 0.1s$  by complementing the PLC-address "255". The necessary instruction in the user program is "COO 255". It is programmed at the beginning of a circulating main or parallel program. The watchdog circuit is used to supervise permanent execution of the user program reliably.

If the PLC executes all programs in the operating mode "RUN" normally, the watchdog relay remains excited. In a different operating mode or if a malfunction occurs in the CPU or the power supply, the relay is released. The watchdog relay is released, too, if the operating mode RUN is quit with the programming unit connected. The respective safety precautions can be taken by using the available two-way contact.

- The yellow lamp SUPPLY OK lights up, if both voltages +5V and +25V are correct.

It is recommended to remove all modules (except N30/N31 and the CPU) from the rack when copying EPROMs in the operating mode LCM. Thus, minimal loading of the 25V-voltage is guaranteed.

### Modification possibility for a fast external reset

On delivery, the jumper WD/R is inserted in WD. Thus, the reset contact is connected to the connection terminal. The outputs are reset in case of a voltage failure within approximately 50 - 200ms depending on the modules of the PCA2. If the jumper is inserted in R, a fast external reset can be effected (provided that supply voltage is available). If the voltage potential of 0V is applied to this terminal, all outputs are reset within 2ms.

The outputs remain reset for at least 100ms. If a reset signal persists, they remain reset for  $t + 25ms$ .

### Block circuit diagram

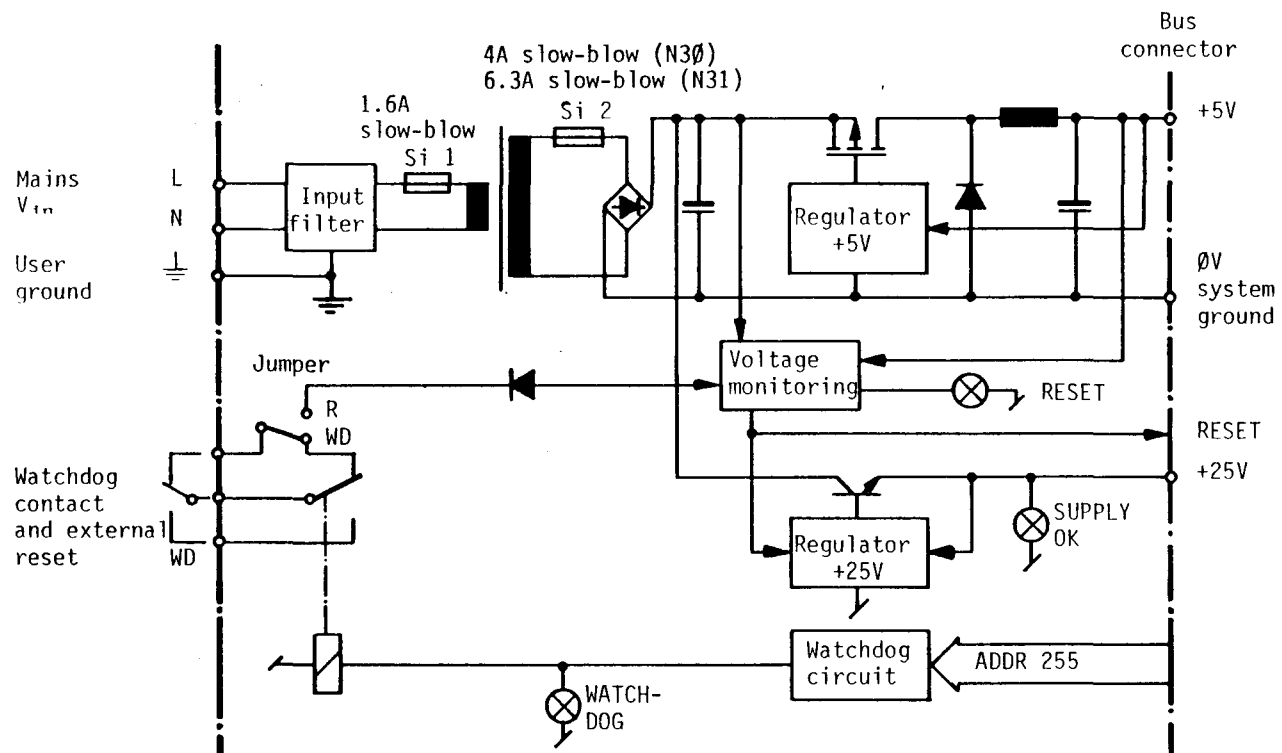

A 7 Type PCA2.C.. Rack units

General

All rack units plug in at the rear in the continuous parallel rack bus with the appropriate bus plugs. Therefore, each module can virtually be plugged into any desired location. For reasons of width, the left-hand locations are reserved for the supply and processor modules. Following these, there are locations for 1 to 10 slim modules (all types E, A, W, F and H). Unused locations are covered with plates.

The rack unit has all-round screening. All connections are located on at the front enabling it to be wall-mounted by using the appropriate angle brackets.

A 7.1 Type PCA2.C21 Rack unit with 8 I/O plug-in locations

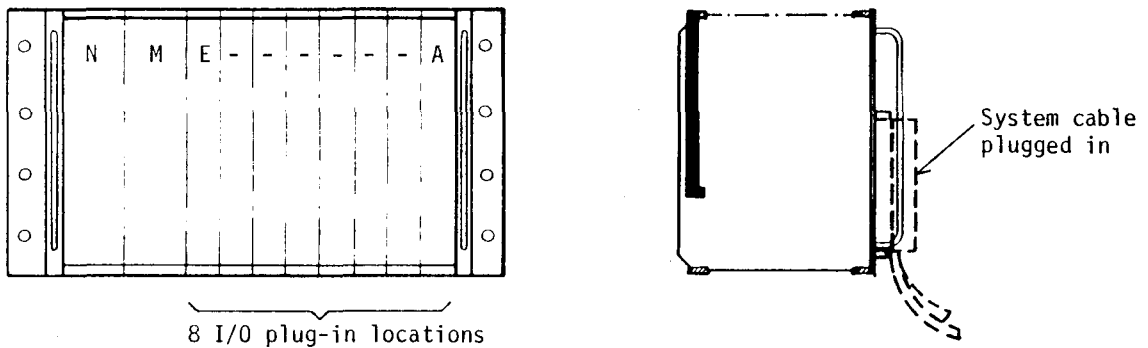

Angle bracket for wall mounting (order no. 4'121'4889'0)

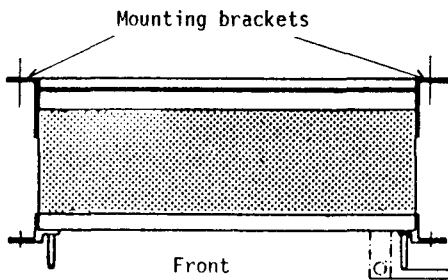

Two angle brackets fastened with screws at the rear of the rack unit enabling it to be wall-mounted.

See dimension diagram.

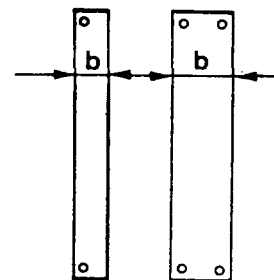

Coverplates

"Slim" version b = 31.4 mm order no. 4'107'4836'0  
 "Wide" version b = 75.8 mm order no. 4'107'4846'0

## A 7.2 Type PCA2.C21 and C30 Extension housing for $I + O > 256$

With certain restrictions concerning the software it is possible to increase the capacity to 256 I + 256 O. For this, the extension housing PCA2.C30 is required for accomodating output modules. In order to meet the internal power requirements of the additional I and O, another power supply module must be inserted in the extension housing C30.

The C21 is the main housing and has to be connected with the extension housing by the bus extension cable PCA2.K92.

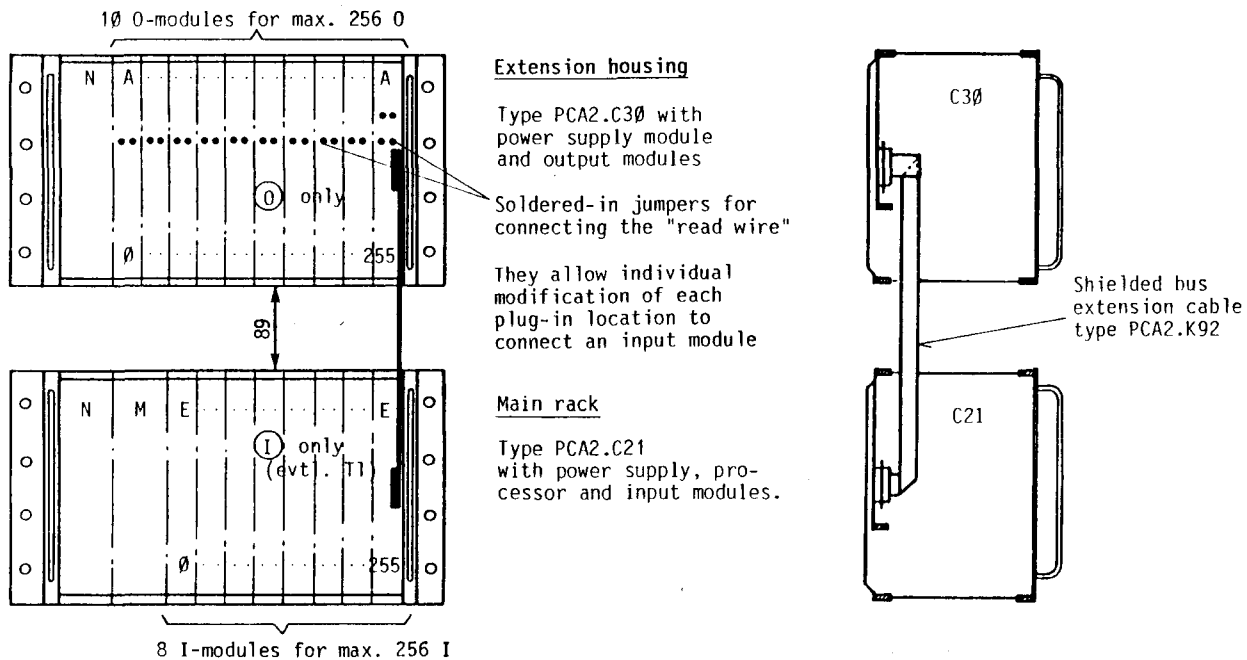

The restrictions regarding the software for the increased no. of I/O are due to the fact that the outputs of the extension housing C30 can only be set or reset, their logic states, however, cannot be interrogated. Consequently:

- Inputs and outputs have the same address range  $0 \dots 255$ .
- Inputs can be interrogated in the normal way and linked to other inputs, flag memories, timers or counters.
- Outputs, however, cannot be interrogated or linked directly, i.e. only the following commands are admissible for outputs in this configuration.

OUT, SEO, REO

In order to be able to process logic states of outputs nevertheless, it is recommended to set a flag memory along with such outputs, if necessary (OUT, SEO, REO). The state of these flag memories which is a copy of the respective output can be interrogated and linked at any time.

It is also possible to use only flags in the entire program instead of outputs, as those are not restricted. In the circulating program the used flags are then transferred (in indexed form) to the corresponding outputs. It must be noted, however, that the last mentioned variant results in longer response times for A.

A 8 Type PCA2.K.. System cables

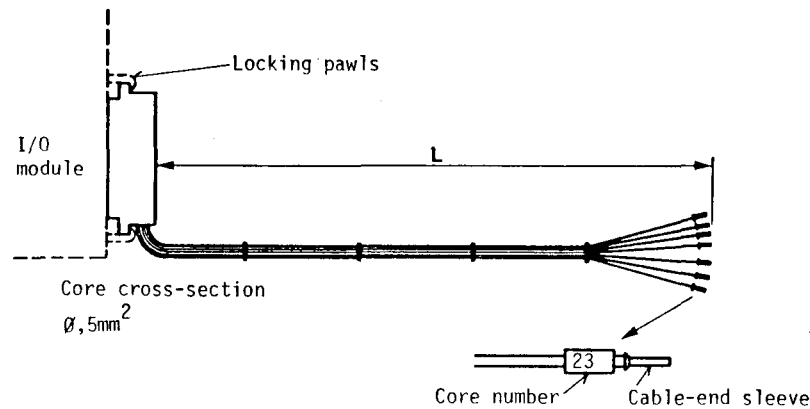

Connection to the front plug of the input and output modules is effected simply and without trouble by using the so-called system cables. This cables are equipped at one end with the module plug with locking device, and, at the other end, with numbered cable-end sleeves. The individual core numbers correspond exactly with the numbers on the pin assignment plans as evident from the relevant I/O documents.

The actual cable is not sheathed but comprises the individual cores which are held together by several cable straps at intervals of approximately 20 cm. This provides the necessary flexibility to enable the cable to be routed in all cable ducts. To make the cable flatter, the straps concerned must only be cut carefully.

Two versions having different lengths are available as required:

PCA2.K1..  
34 cores

PCA2.K2..  
40 cores

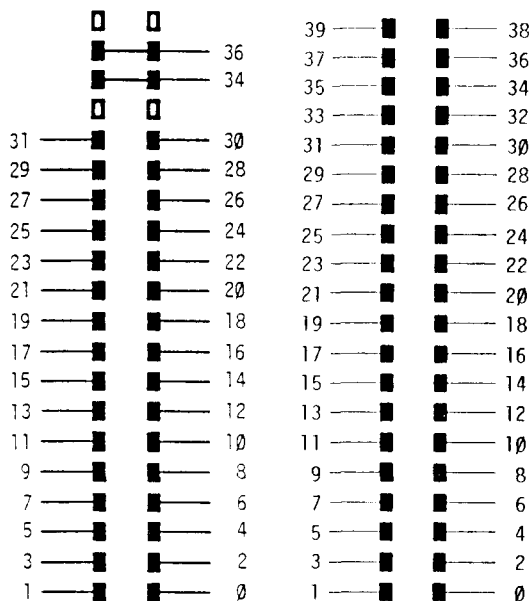

Front view of the modules

PCA2.K1.. with 34 cores for all I/O modules (except PCA2.A40 and A31 see module leaflet)

- PCA2.K11 length L 1.5m
- PCA2.K12 length L 2.5m (standard)
- PCA2.K14 length L 4.0m
- PCA2.K15 length L 5.5m

PCA2.K2.. with 40 cores, principally for 0-module PCA2.A40 and A31, but also for all other I/O modules

- PCA2.K21 length L 1.5m
- PCA2.K22 length L 2.5m (standard)
- PCA2.K24 length L 4.0m
- PCA2.K25 length L 5.5m

The module plug is also available without cable, under the designation PCA2.K01.

A 8.1 Cable routing with system cables and external interfaces

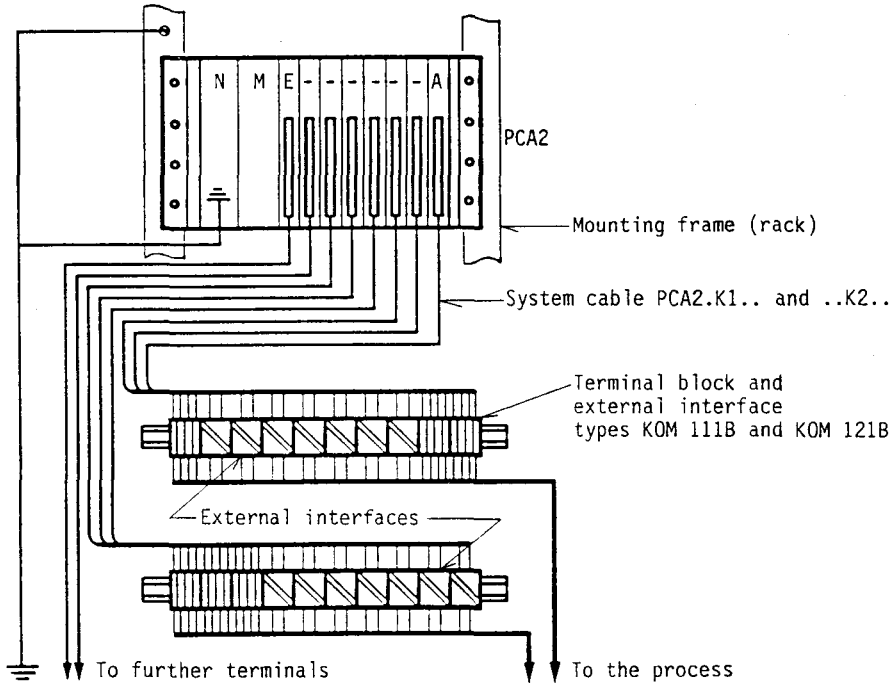

As the illustration above shows, the use of system cables to the PCA2 facilitates the arrangement of the connecting modules to the process in a simple and clear manner. In order to achieve a high degree of interference immunity, the PCA2 must be well grounded via the supply module. The ground connection is distributed to all the modules via the tightly fastened front screws.

A 8.2 Interference immunity

The system cables and also the cables between switch cabinet and process can be routed without problems in the normal cable duct for the contactors, valve and motor cables, as long as the distances do not exceed approximately 50 m. It is recommended that a separate cable duct be used in case of greater distances.

The interference immunity of the I/O modules is tested in accordance with IEC 255-4/E5 class III in order to be able to give reproducible values. This means, that, due to the well-planned circuitry principle of the SAIA<sup>®</sup>PLC, high voltage peaks (applied directly to the 24V inputs/outputs!) do not interfere with the function and cannot lead to the destruction of components (see figures below):

PCA2 design principle (cross-section)

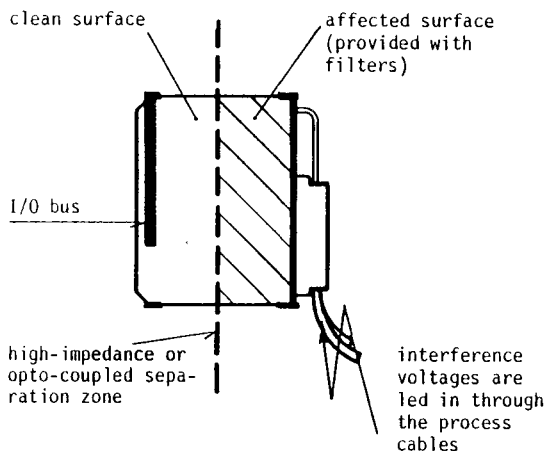

Interference voltage test in acc. with IEC

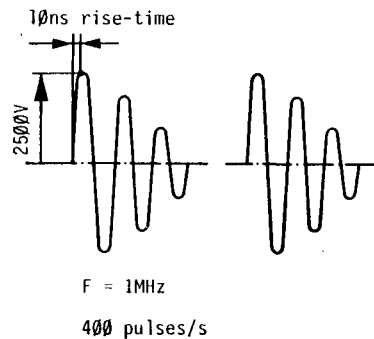

Notes:

**Circuit information:**

- 1 The PLC mounting frame, supply module earth terminals and the negative pole of the 24V-supply (with the exception of the isolated I/O) are to be connected to a good, common ground. In order to distribute the ground to all modules, their front screws are to be securely tightened.
  - 2 The overall 24VDC supply can be a pulsating DC. It is only necessary to have a regulated smoothed voltage, where this is demanded by the transmitter or the load. Proximity switches for example have to some extent close voltage limits and will in most cases only tolerate ripple of up to 10%.
  - 3 The power supply module is operative on starting up. The "Fast RESET" function is feasible by reinserting the internal jumper R-WD from WD into R (RESET).
  - 4 If in sink mode, the load resistors (L) are connected to a regulated +24V-supply, NPN proximity switches can also be connected here.
  - 5 NAMUR proximity switches are connected to NAMUR inputs type E11.\*
  - 6 With the isolated input circuit type E20 - independent of the type of connection - the closing of a contact or the driving of a proximity switches can also be connected here. In this event, the supply voltages can be of differing potentials.
  - 7 For damping the turn-on current of larger signal lamps, these can be fitted in A10 with bleeder resistors. With the A10 module, the positive potential could be different for each load.
  - 8 The A31 isolated 0-module can be supplied with a separate circuit. The 16 outputs can be divided into 4 groups on the negative side.
  - 9 With the A40 0-module, the 32 outputs on the positive side can be divided into 4 groups.
  - 10 In the case of new modules, this bridge must be removed for sink mode.
- \*) Details see PCA2.E10 and PCA2.E11, but also the special NAMUR module PCA2.E30.

24V    0V    Signal    Terminal System Module    I-modules  
 +    +    -    transmitter    block    cable    connector

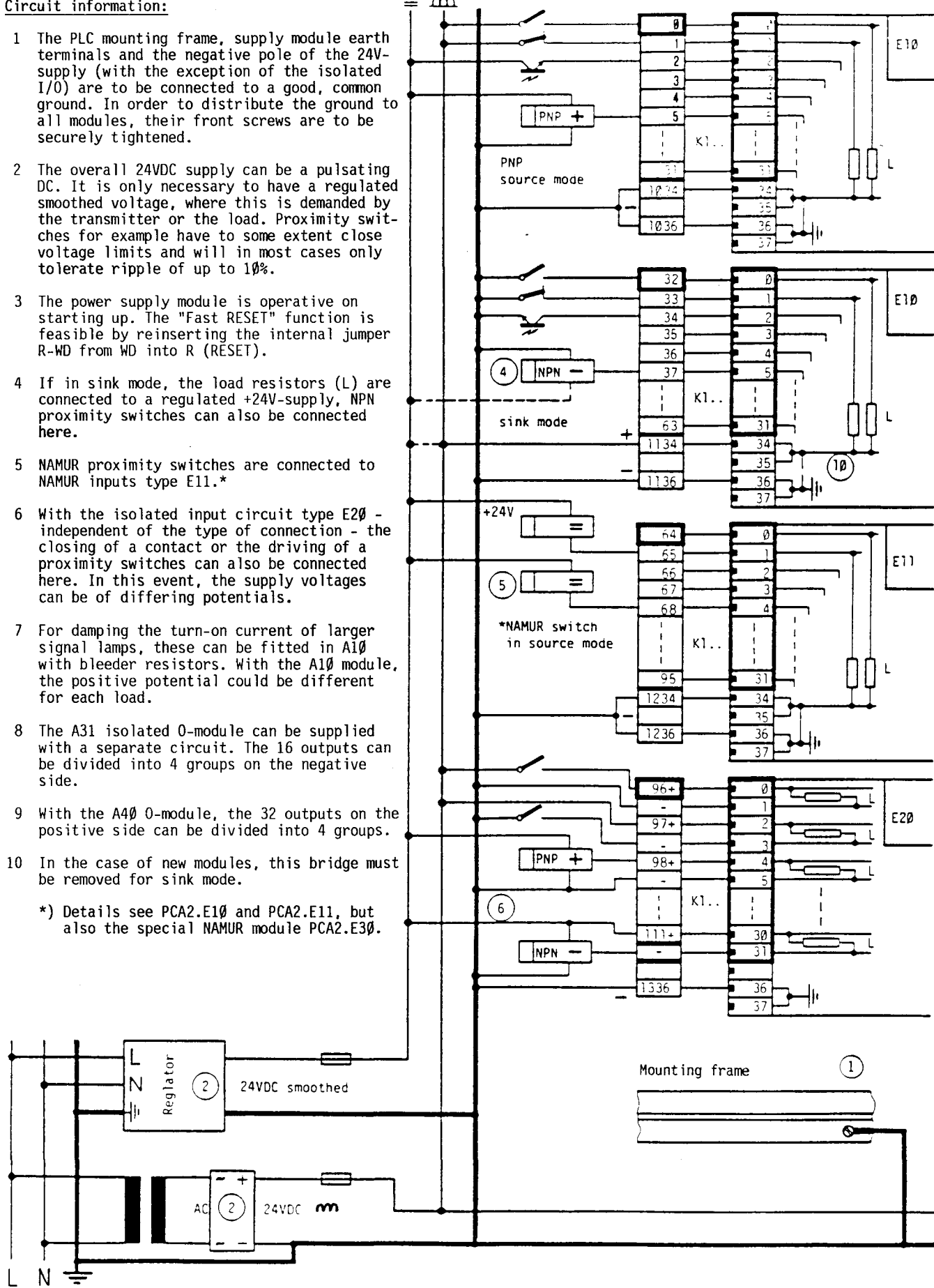



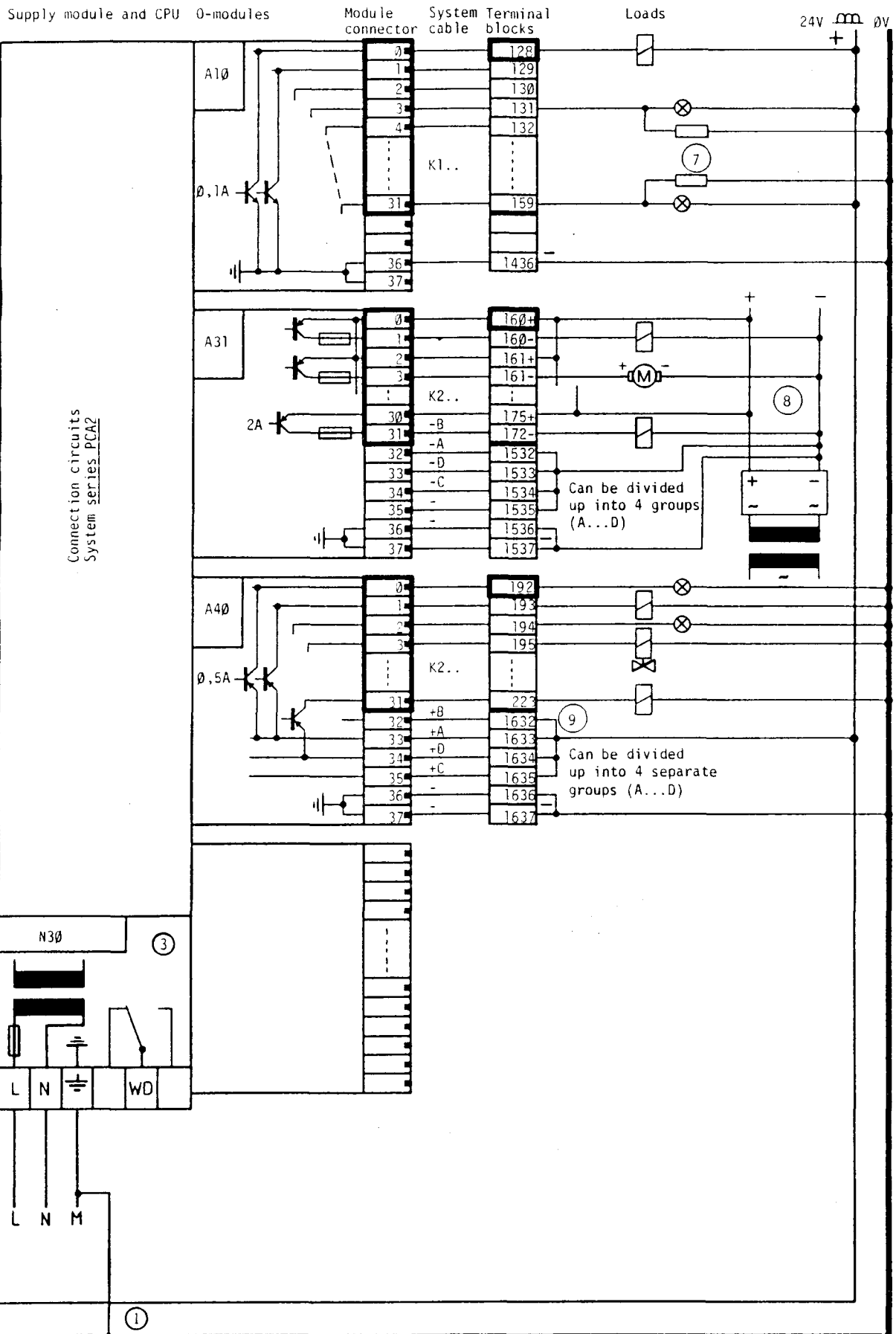

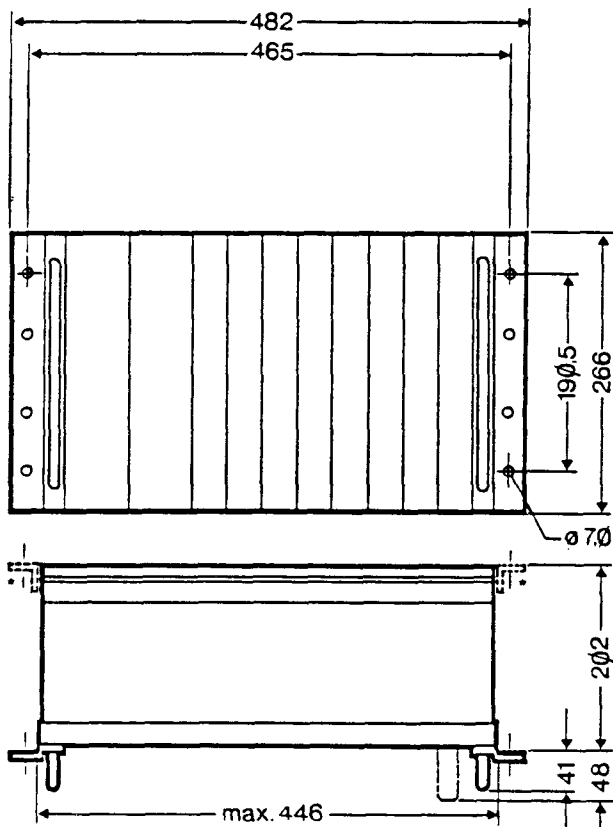
A 8.3 Dimensions of the PCA2 series

\* Fastening bracket  
for wall-mounting  
(accessory)

## A 9 Brief instruction for operating a PCA2

### a) Equipment

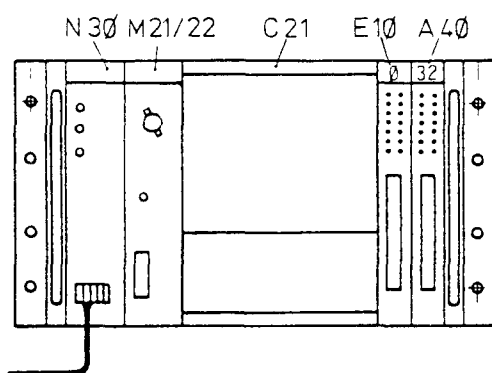

The following modules are plugged into the rack unit from the left to the right:

- the power supply module PCA2.N30
- the processor module PCA2.M21 (or M22/32)
- the input module PCA2.E10
- the output module PCA2.A40 or A10
- the buffered RAM memory module R95/R96 is plugged onto socket PROG of the processor module

The large gap between M21 and E10 is of advantage, as the storage module can be easily removed at any time.

### b) Addressing of the I/O

In order to try out the programming examples in manual "Software 1H", it is recommended to select the addresses 0...31 for the I-module PCA2.E10 and 32...63 for the O-module PCA2.A40.

The selection is effected with the DIL-switches by setting the corresponding basic addresses:

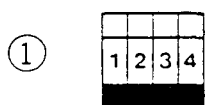

E10-module, basic address 0



A40-module, basic address 32

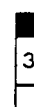

depressed

### c) Power supply

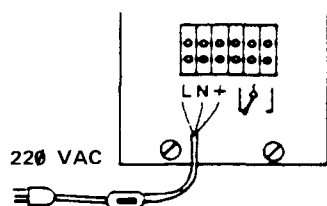

- ③ For "playing", it is recommended to provide for a switch in the mains connection in order to reset all resettable elements and the STEP-counter to the defined starting positions at any time by switching off the PCA2.

### d) Insertion of the RAM-module and connection to the programming unit P05

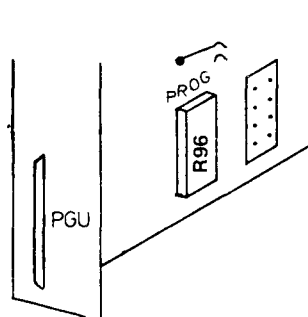

- ④ The buffered RAM-memory module PCA1.R95 or R96 is plugged onto socket "PROG" (groove at the top). The jumper disposed above is inserted in "EPROM" (factory setting). Jumper "WRITE ENABLE" must be inserted (factory setting).
- ⑤ Programming unit P05 is connected with connector PGU and secured with the sliding lock.

e) Functional checks

⑥ Set operating mode selector switch to "MAN"

⑦ Apply voltage to the power supply module

----> The yellow N30 lamp "SUPPLY OK" lights up

----> The yellow M21 lamp "CPU RUN" flashes 1s on, 1s off

----> The P05-display lights up

If the operating mode selector switch was set to "MAN", functioning of the I/O-modules can be checked.

⑧ Type in  15 on P05.

If input 15 is activated, the display in the "operand" changes from 0 to 1 (cannot be checked before connecting the simulating unit S10 according to point 18 ).

⑨ Type in  32  1 .

The LED of output 32 lights up.

Upon entering 0 the LED goes out again, i.e. the corresponding output is no longer active.

f) Programming example "Flashing indicator"

- ⑩ Set operating mode selector switch to "PROG".
- ⑪ Switch on power supply of the PCA2. The CPU lamp (yellow) flashes 1s on, 1s off.
- ⑫ Enter the following indicator program with P05.

	<u>STEP</u>	<u>CODE</u>	<u>OPERAND</u>	<u>Program in mnemonic code</u>
A, E	(0000)*	(00)	(0000)	
E	(0001)	02	256	STL 256
E	(0002)	14	256	STR 256
E	(0003)	00	5	0.5s
E	(0004)	13	32	COO 32
E	(0005)	20	1	JMP 1
E	(0006)	(00)	(0000)	

\*) The values in brackets are displayed although they do not have to be entered.

- ⑬ Set operating mode selector switch to "RUN". Switch off PCA2 and switch on again.  
---> Program is being executed, i.e. output 32 flashes 0.5s on and 0.5s off (frequency 1Hz).
- ⑭ If the time base must be modified to 1/100s, proceed as follows:  
Switch off PCA2, reinsert jumper (circuit board in the middle, on the left) from 1/10 to 1/100. Switch on PCA2 again.  
---> The output 32 flashes 10 times faster, i.e. at a frequency of 10Hz. The selection of the time base 1/100s is also recognized by the increased flashing frequency of the CPU lamp (yellow).

g) Flashing indicator example with activated watchdog

If in the preceding example the watchdog is to be activated, the instruction COO 255 must be added to this circulating program. In order that this instruction is executed during each cycle independent of the indicator program, enter SEA before.

The supplement is programmed as follows:

- ⑮ Set operating mode selector switch to "PROG".
- ⑯ Enter:

				<u>Mnemonic code</u>
A	5	(20)	(1)	
E	(0005)	19	0	SEA 0
E	(0006)	13	255	COO 255
E	(0007)	20	1	JMP 1
E	(0008)	(00)	(0000)	

**PART B**      **Input/output modules as well as  
additional and display modules**

**Chapter B 1**      **Plug-in input/output modules**

**Chapter B 2**      **Programming units, additional units  
and accessories**

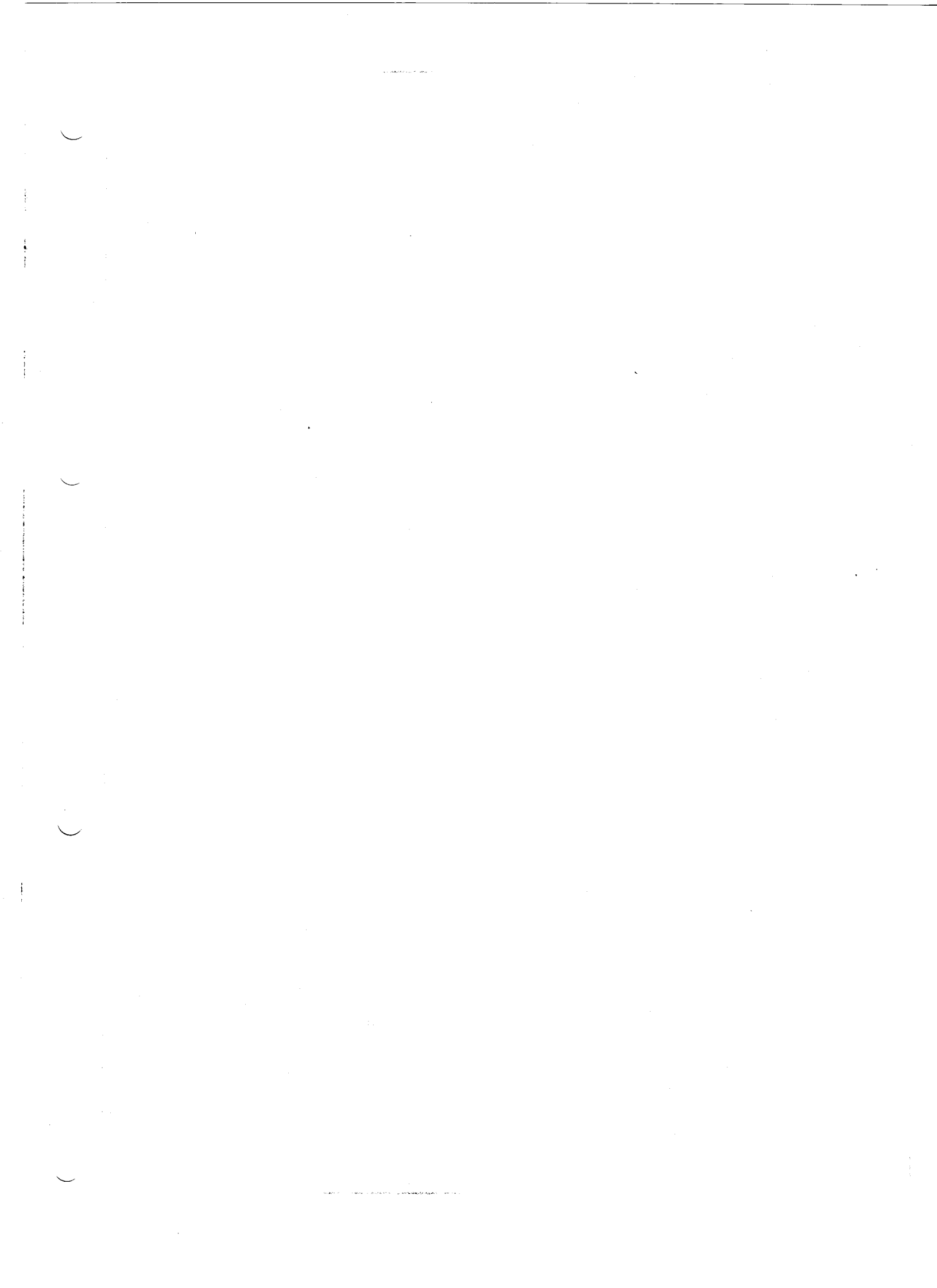

## B 1 Plug-in input/output modules

### B 1.1 Digital input modules

- PCA2.E10 - 32 inputs, electrically connected  
24VDC smoothed or pulsating  
Input current: 10mA
- PCA2.E11 - 32 inputs, for NAMUR proximity switches, electrically connected  
24VDC smoothed  
Input current: 0...6mA
- PCA2.E20 - 16 inputs, opto-isolated, each input is independent and  
potential-free  
24VDC smoothed or pulsating  
Input current: 12mA
- PCA2.E30 - 32 inputs, for NAMUR-proximity switches, electrically connected  
8.4VDC from 24VDC supply voltage  
Input current: 0...3.2mA
- PCA2.E60 - 32 inputs, opto-isolated  
24VDC smoothed or pulsating  
Input current: 10mA

### B 1.2 Digital output modules

- PCA2.A10 - 32 outputs, electrically connected  
5...32VDC smoothed or pulsating  
Output current: 1mA...0.1A sink operation
- PCA2.A21 - 16 outputs with relay contacts,  
opto-isolated  
50VAC/2A, 50VDC/1A, 60VDC/0.8A
- PCA2.A31 - 16 outputs, opto-isolated  
6...36VDC smoothed or pulsating  
Output current: 5mA...2A, source operation
- PCA2.A40 - 32 outputs, electrically connected  
5...32VDC, smoothed or pulsating  
Output current 5mA...0.5A, source operation



### B 1.3 Analog input/output modules

#### Analog input/output module PCA2.W1

##### 12-bit resolution

PCA2.W10	- 8 input channels (without output)
PCA2.W12	- 8 input channels, 2 output channels
PCA2.W14	- 8 input channels, 4 output channels
PCA2.W15	- (without input), 4 output channels
PCA2.W16	- 8 input channels, (without output)

#### Analog input modules PCA2.W2

##### 8-bit resolution

PCA2.W20	- 16 input channels 0...10V Standard
PCA2.W21	- 16 input channels 0...5V
PCA2.W22	- 16 input channels 0...20mA
PCA2.W25	- 32 input channels 0...10V Standard
PCA2.W26	- 32 input channels 0...5V
PCA2.W27	- 32 input channels 0...20mA

### B 1.4 Counter module for 10...200kHz

PCA2.H1	- Counter module
PCA2.H11	- Additional counting mode module
PCA2.H12/13	- Additional stepping motor module

### B 1.5 Data line switching module

PCA2.F20	- For 4 serial interfaces RS 232c or current loop 20mA
----------	--

B 1.1 Digital input modules

B 1.1.1 Type PCA2.E1Ø Input module, electrically connected

Technical data

Number of inputs per module	32, electrically connected
Input voltage $V_{in}$	24VDC smoothed or pulsating
Input current at 24VDC	1ØmA
Typical input delay	8ms

Presentation

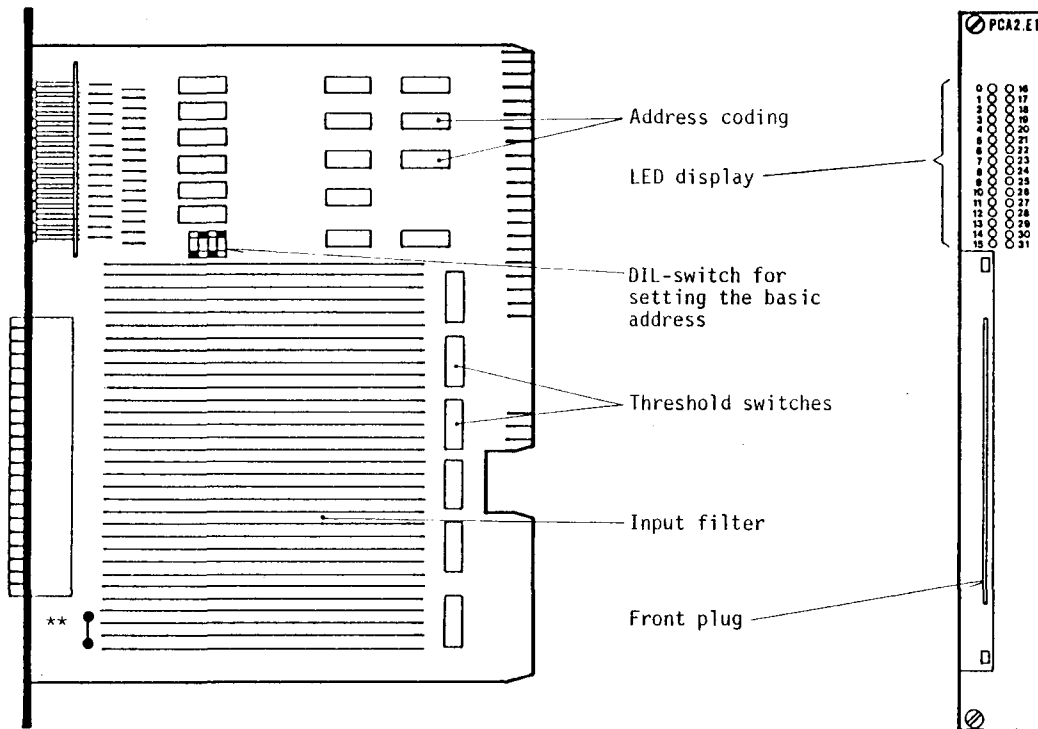

Definition of input voltages

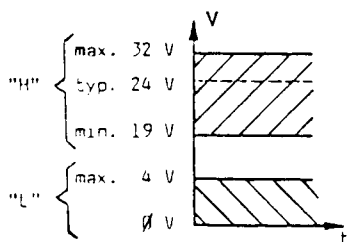

On account of the 8ms input delay pulsating DC-voltage is sufficient for external supply.

\*) This jumper must be removed in sink operation.

## Input circuit

Depending on the external circuitry, this module can be used in source or sink operation.

### Source operation or positive logic (normal case):

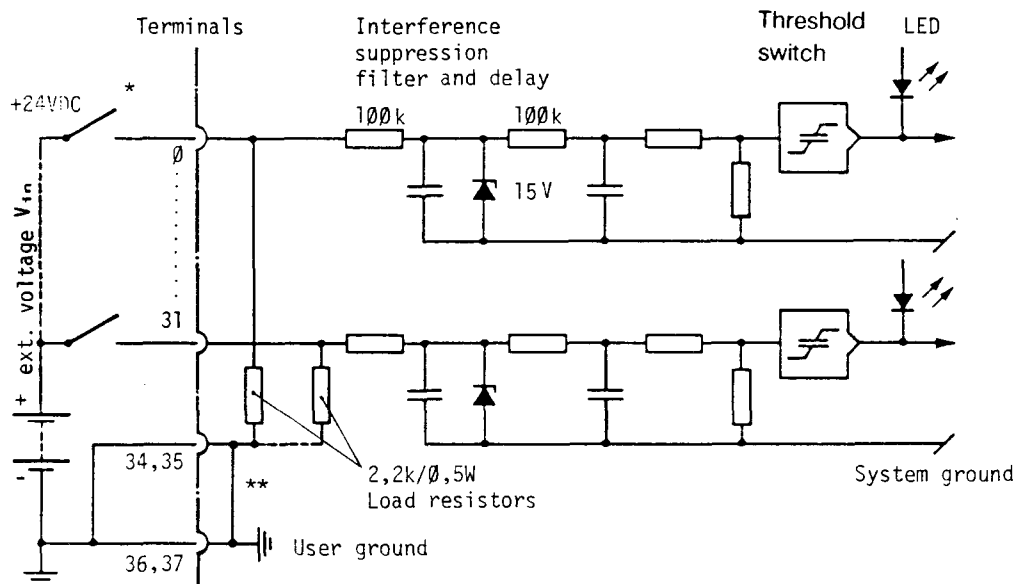

Switch closed (positive at input): "H"  $\hat{=}$  LED ON  
 Switch open (negative at input): "L"  $\hat{=}$  LED OFF

\*) PCA2.E10 is also suitable for NAMUR switches which can carry a current of 10mA at 24VDC and 2.2k $\Omega$ .

### Sink operation or negative logic:

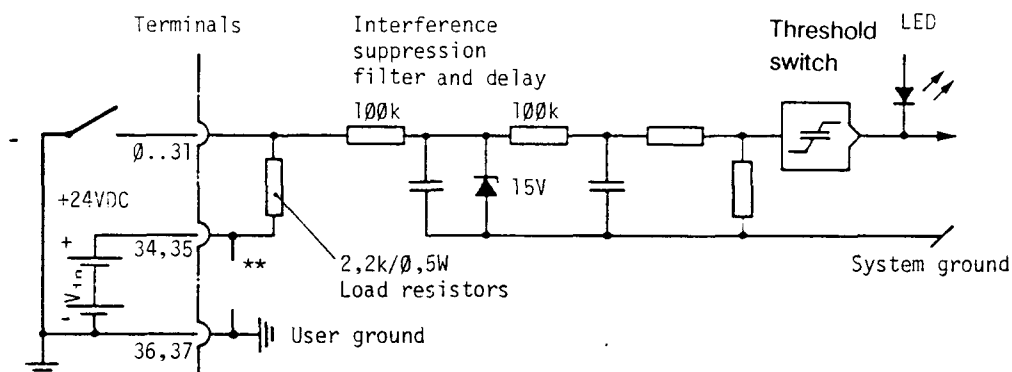

Switch closed (negative at input): "L"  $\hat{=}$  LED OFF  
 Switch open (positive at input): "H"  $\hat{=}$  LED ON

\*\* ) Remove jumper in sink operation!

Connector pin assignment

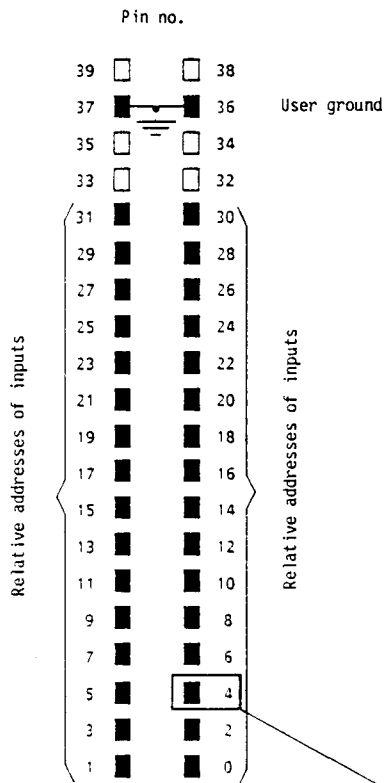

View to module front

Module addressing

Setting the basic address on the DIL switch:

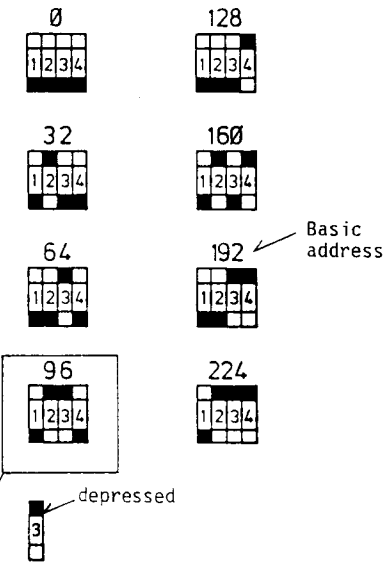

Absolute address of input  
= basic address + relative address

(Example: E100 = 96 + 4)

### B 1.1.2 Type PCA2.E11 Input module for NAMUR proximity switches

Due to the object distance, NAMUR proximity switches supply a current from 0 to 6mA. To give consideration for these special conditions, two resistors are changed per input in the NAMUR version as opposed to the standard PCA2.E10 card.

#### Technical data

Number of inputs per module      32, electrically connected

Voltage source  $V_{in}$  in series with NAMUR proximity switches      24VDC smoothed

Typical input delay      8ms

#### Input circuit

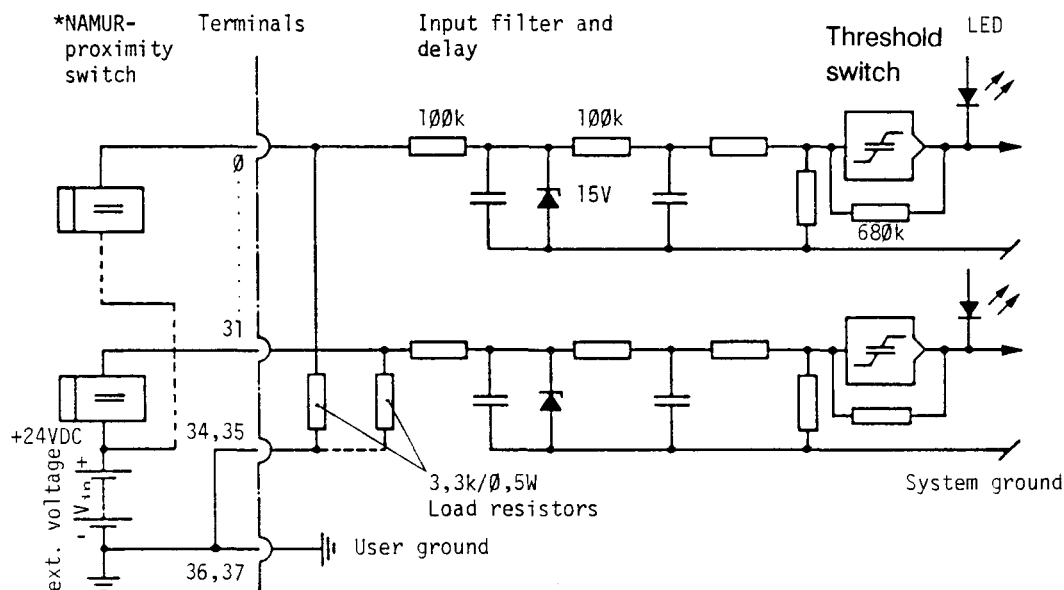

#### Definition of the input variables

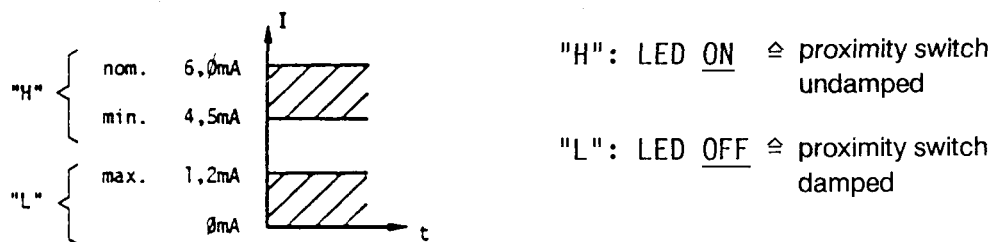

See PCA2.E10 for connector pin assignment and module addressing.

\*) PCA2.E11 is suitable for NAMUR proximity switches which can carry a current of 6mA at 24VDC and 3.3k $\Omega$ .  
Type PCA2.E30 is a special NAMUR-input module.

B 1.1.3 Type PCA2.E2Ø Input module opto-isolated

Technical data

Number of inputs per module	16, opto-isolated (between process, CPU and each other)
Input voltage $V_{in}$	24VDC, smoothed or pulsating, each input is independent and potential-free
Input current at 24VDC	12mA
Typical input delay	7ms
Isolation voltage of optocoupler	min. 2000V

Presentation

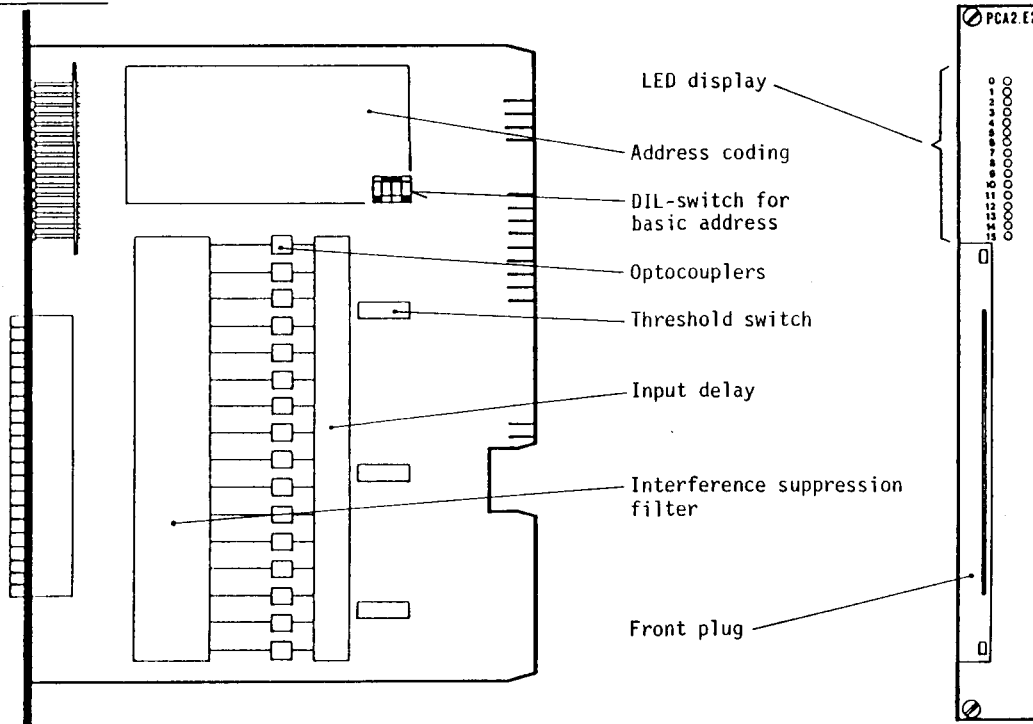

Definition of input voltage  $V_{in}$

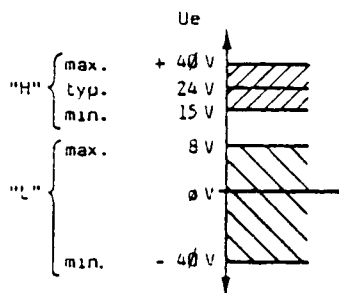

Input circuit operating modes

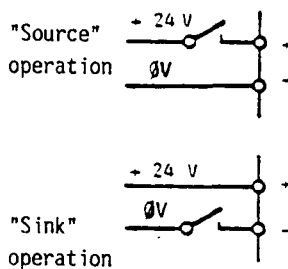

Due to the 7ms input delay, pulsating DC-voltage is sufficient for the external supply.

With input contact closed, the LED lights up in both cases.

Input circuit

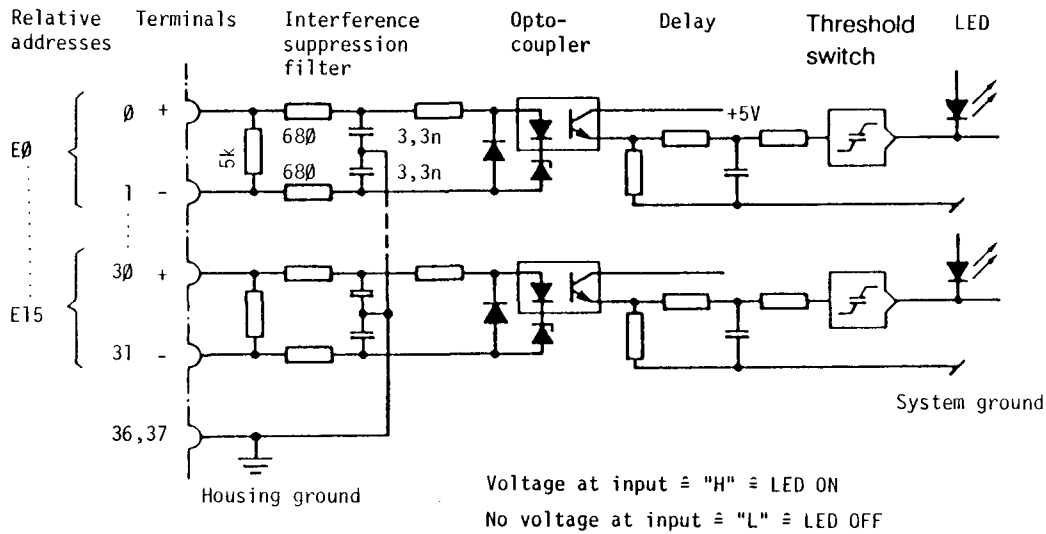

Connector pin assignment

Relative addresses	Pin no.
	39 □ □ 38
	37 ■ ■ 36
	35 □ □ 34
	33 □ □ 32
15	-31 ■ ■ 30+
14	-29 ■ ■ 28+
13	-27 ■ ■ 26+
12	-25 ■ ■ 24+ see example
11	-23 ■ ■ 22+
10	-21 ■ ■ 20+
9	-19 ■ ■ 18+
8	-17 ■ ■ 16+
7	-15 ■ ■ 14+
6	-13 ■ ■ 12+
5	-11 ■ ■ 10+
4	- 9 ■ ■ 8+
3	- 7 ■ ■ 6+
2	- 5 ■ ■ 4+
1	- 3 ■ ■ 2+
0	- 1 ■ ■ 0+

Module addressing

Setting the basic address on DIL switch:

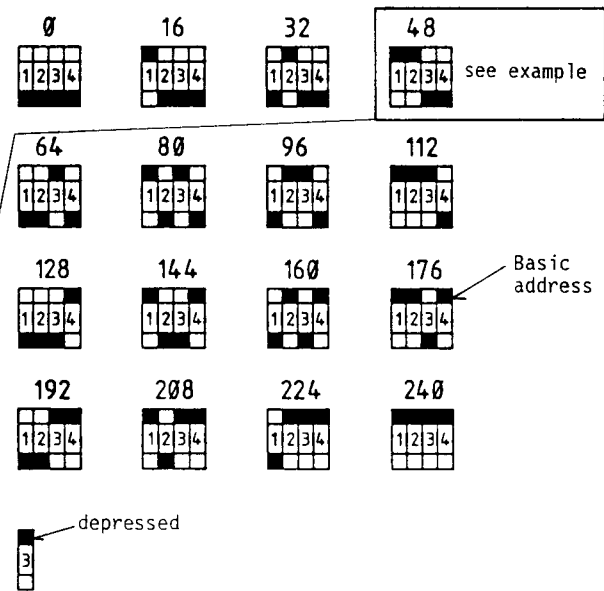

View to module front

Absolute address of input =  
basic address + relative address

(Example: E60 = 48 + 12,  
cores 24/25)

### B 1.1.4 Type PCA2.E3Ø Input module for NAMUR proximity switches

Proximity switches according to DIN standard 19234 resp. NAMUR\* are simple inductive DC-voltage switches using 2-wire technology. Their power consumption varies depending on the object distance.

The input module PCA2.E3Ø corresponds to the standard as regards idling voltage, short-circuit current and switching points. However, line break and short-circuit monitoring of the line are not provided.

#### Technical data

Number of inputs per module	32, electrically connected
Power supply for NAMUR proximity switches	4 groups of 8 switches $V_o = 8.4$ VDC (per module)
External supply voltage $V_{in}$	24VDC, smoothed or pulsating $\pm 20\%$
Typical input delay	2 ms
Short-circuit current	8.4 mA

\*) NAMUR = Normen-Arbeitsgemeinschaft Mess- und Regeltechnik  
(Committee for measuring and control engineering standards)

#### Presentation

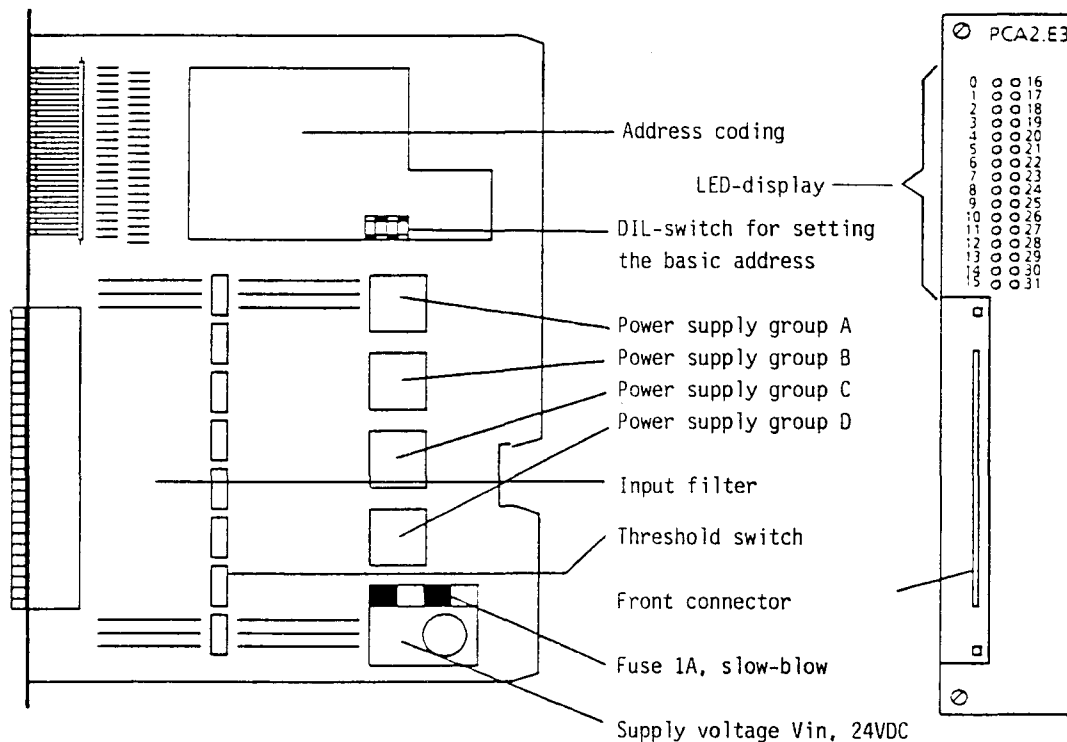



Block circuit diagram and input circuit

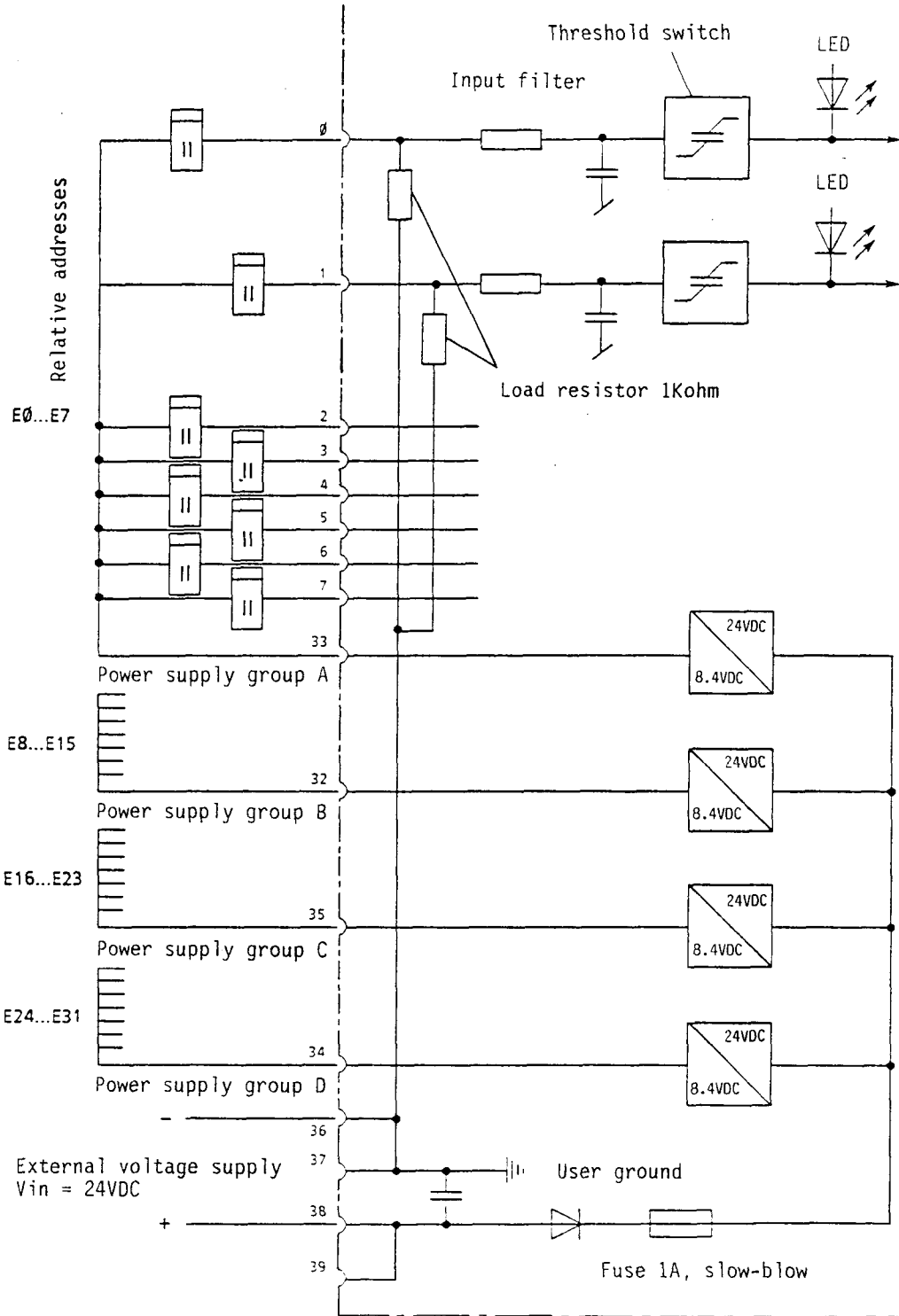

Definition of the input variables

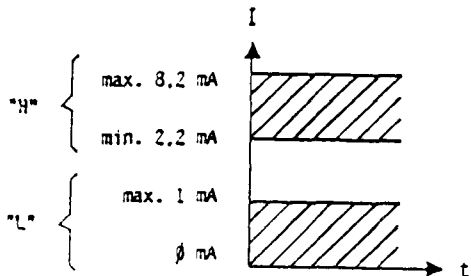

"H": LED ON  $\hat{=}$  proximity switch undamped

"L": LED OFF  $\hat{=}$  proximity switch damped

Connector pin assignment

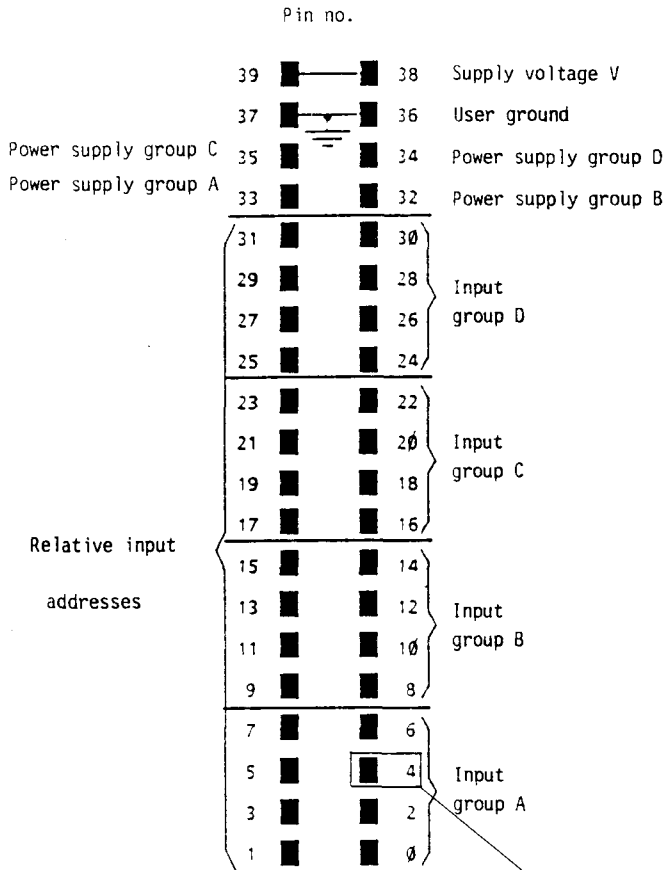

Front view of the module

Addressing of module

Setting of the basic address via DIL-switch:

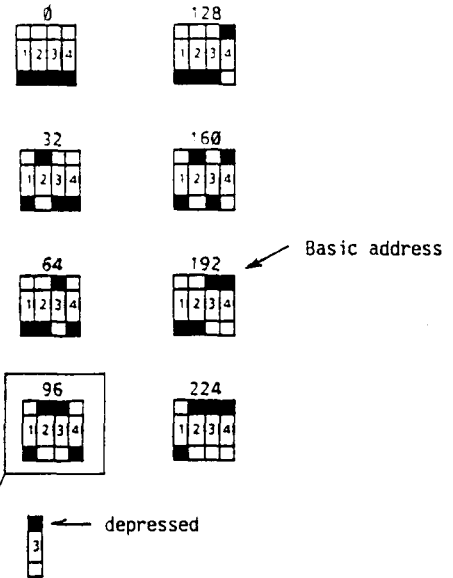

Absolute address of the input = basic address + relative address

(Example: E100 = 96 + 4)

### B 1.1.5 Type PCA2.E60 Input module opto-isolated

#### Technical data

Number of inputs per module	32, opto-isolated (between process and CPU)
Input voltage $V_{in}$	24VDC smoothed or pulsating
Typical input current at 24VDC	10mA
Typical input delay	7ms
Isolation voltage of optocouplers	AC 5000V eff.

#### Presentation

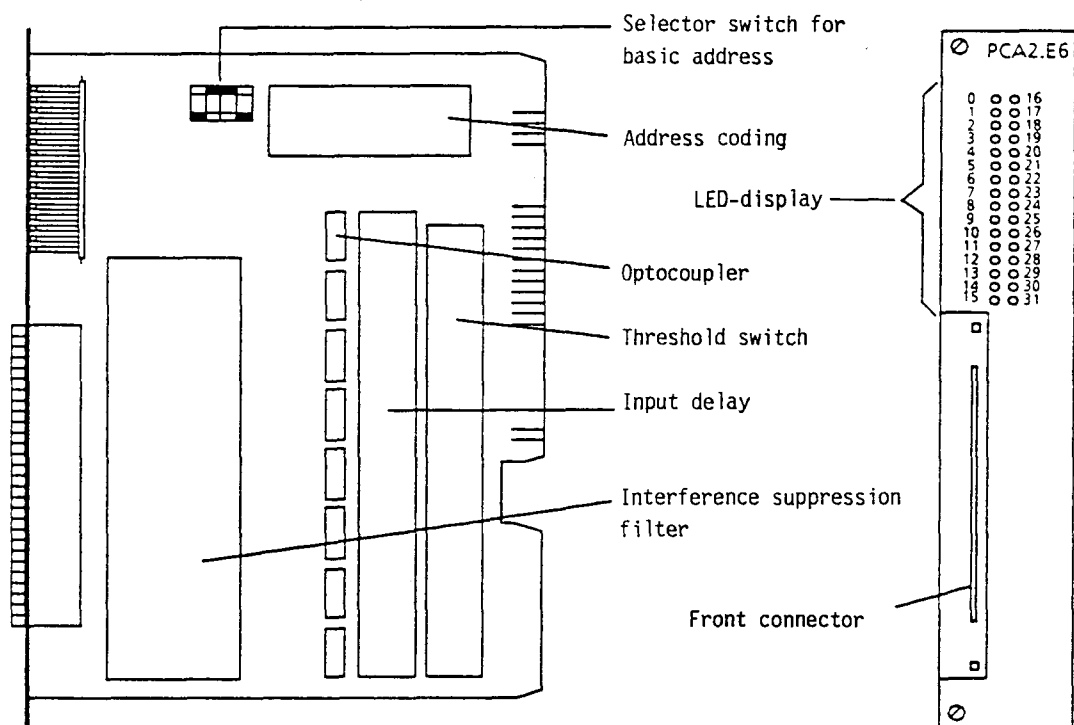

#### Definition of input voltage $V_{in}$

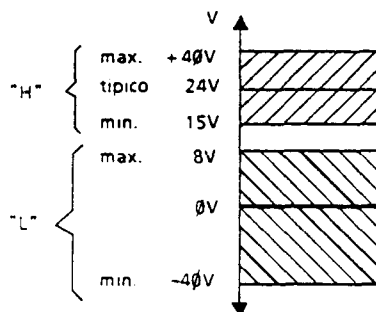

Due to the 7 ms input delay, pulsating DC-voltage is sufficient for the external supply.

Input circuit (for source operation or positive logic only)

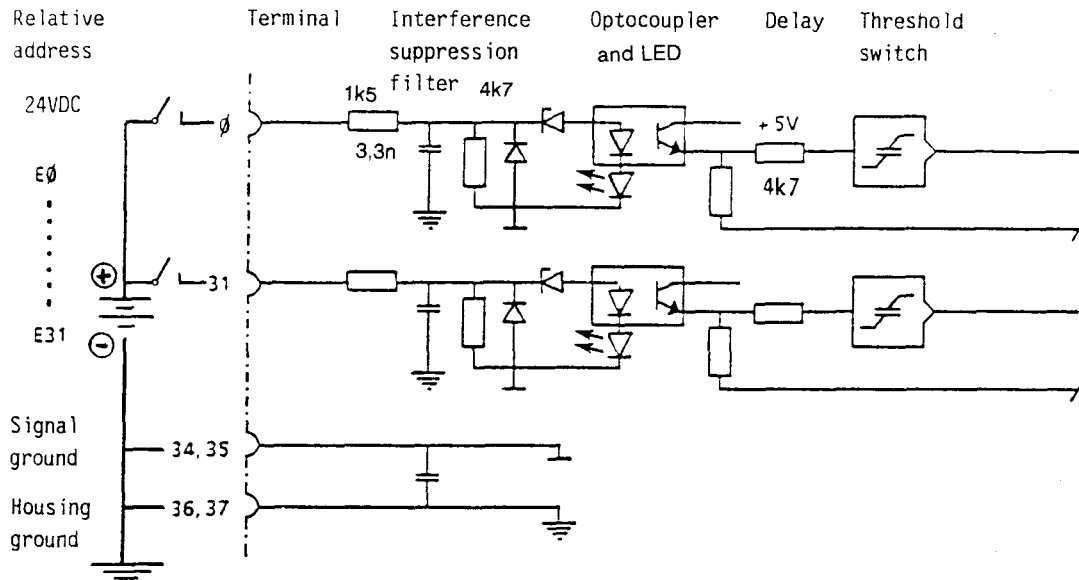

Switch closed: "H" ≅ LED ON  
 Switch open : "L" ≅ LED OFF

Connector configuration

Relative address	Pin no.	Relative address
39	38	
37	36	Housing ground
35	34	Signal ground
33	32	
31	30	30
29	28	28
27	26	26
25	24	24
23	22	22
21	20	20
19	18	18
17	16	16
15	14	14
13	12	12
11	10	10
9	8	8
7	6	6
5	4	4
3	2	2
1	0	0

View to module front

Module addressing

Setting the basic address on DIL-switch:

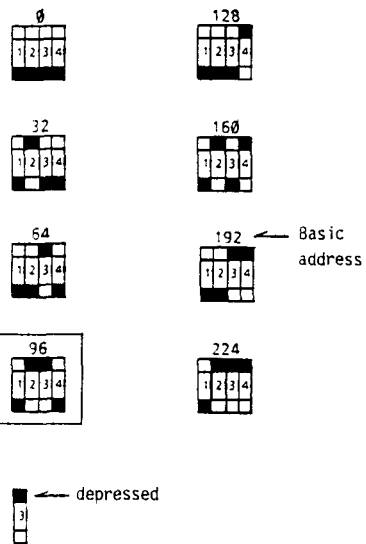

Absolute address of input = basic address + relative address

(Example: E100 = 96 + 4)

## B 1.2 Digital output modules

### B 1.2.1 Type PCA2.A10 Output module, electrically connected for 0.1A (sink operation, i.e. negative switching)

#### Technical data

Number of outputs per module	32, electrically connected
Output current range	1mA...0.1A In the voltage range 5...24VDC the load resistance must be at least 240Ω
Operating mode	Sink operation (negative switching)
Voltage range $V_{out}$	5...32VDC smoothed or pulsating
Voltage drop	1V at 0.1A
Typical output delay	10μs (ohmic load)

#### Presentation

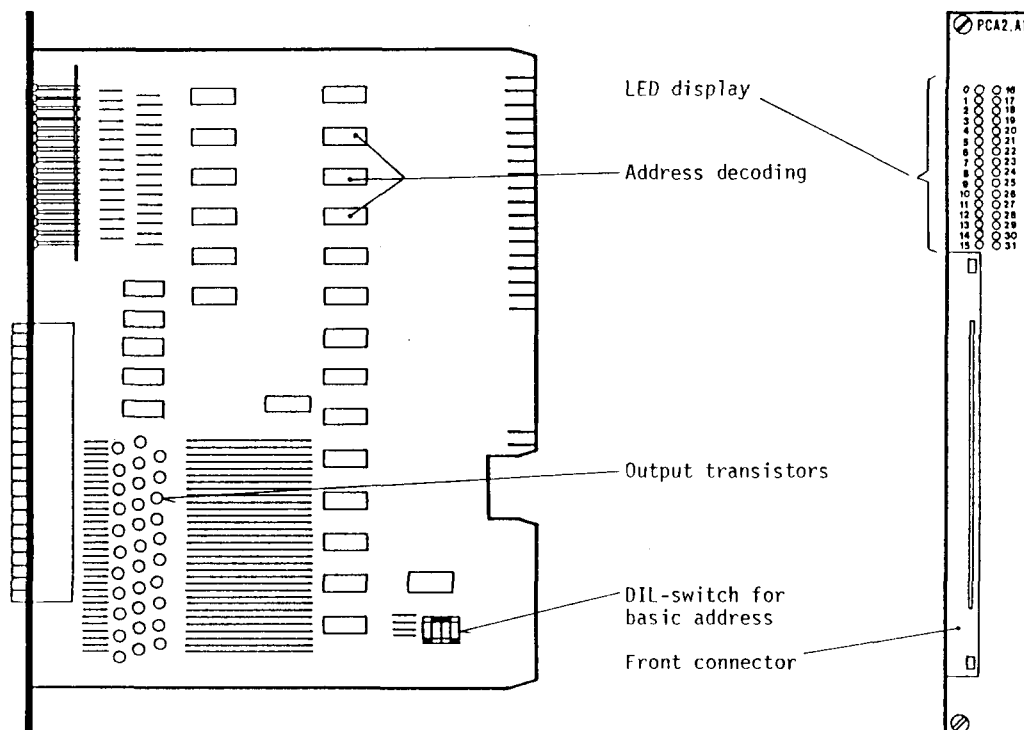

**Note:** Interference immunity of this negative switching output module is below the 2500V laid down in A 8.2. Therefore module PCA2.A10 should only be used where its specific characteristics are required. In all other cases, the more robust modules PCA2.A31 and A40 are to be employed.

Output circuit

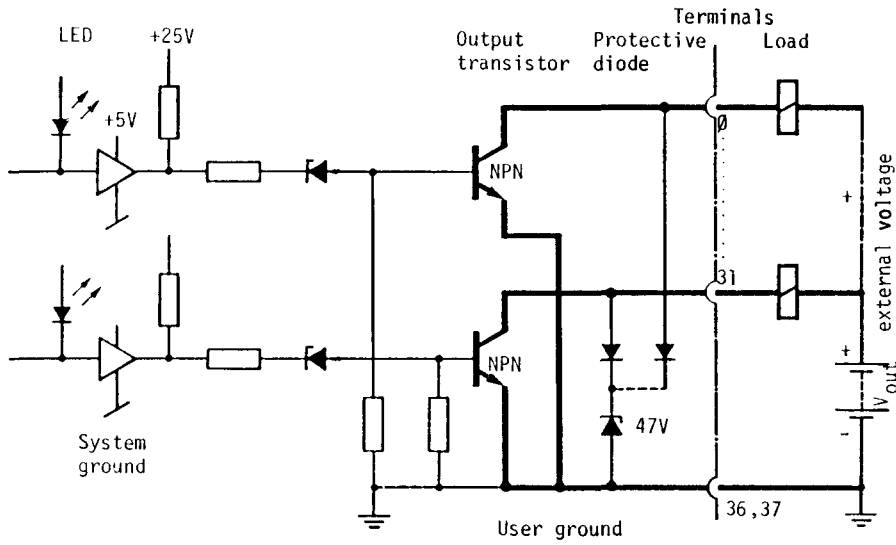

Output conducting (set)      ≙ LED ON  
 Output non-conductive (reset) ≙ LED OFF

Connector pin assignment

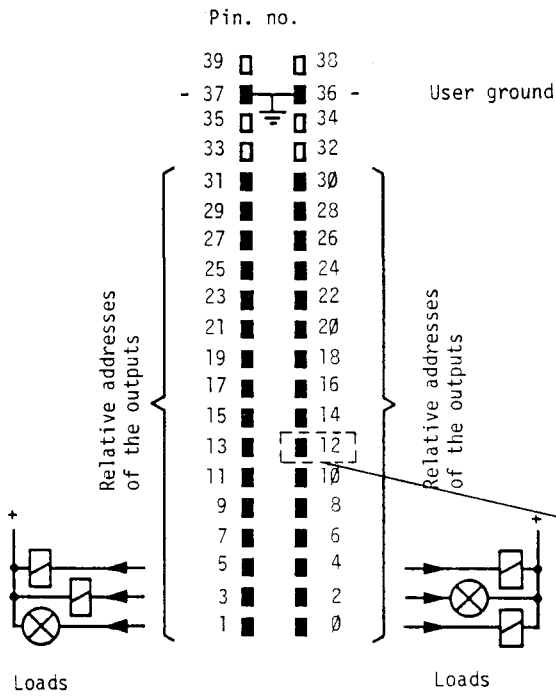

View to module front

Module addressing

Basic address setting via DIL-switches:

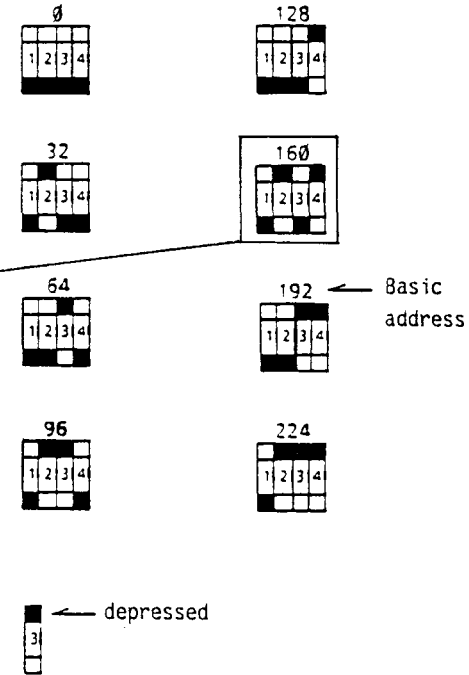

Absolute address =  
 basic address + relative address

(Example: A172 = 160 + 12)

### B 1.2.2 Type PCA2.A21 Output module with relay contacts

#### Technical data

Number of outputs per module	16, galvanically isolated, normally open contacts
Nominal power rating	2A, 50VAC 0.8A, 60VDC *) 1A, 50VDC *) (resistive load, inductive load with additional spark suppression)
Minimum power rating	10mA, 15V
Contact life (resistive load and 1 switching cycle/s)	2A, 50VAC : 0.6 mio switching cycles 0.8A, 60VDC: 4 mio switching cycles
Relay coil supply	24VDC ±15%
Interference protection	IEC 255.4 class 3 and 801.4 class 3

\*) It is recommended to use transistor outputs when connecting DC-voltages, in order to ensure reliable switching.

Note: To achieve maximum interference protection, position the module PCA2.A21 as far away from CPU and I/O-cards as possible.

#### Presentation

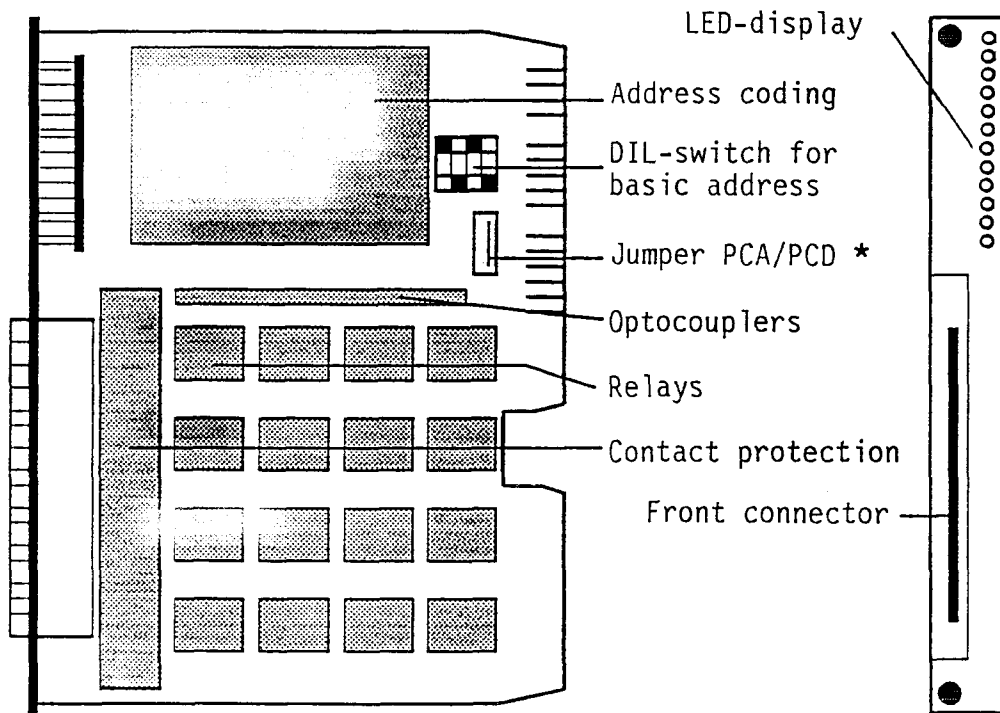

\* The jumper PCA/PCD must be removed.

Connector pin assignment

Relative addresses	Connector no. (pin no.)	
	39 □ □ 38	
	37 ■ ■ 36	User ground
	35 ■ ■ 34	Relay coil minus -
	33 ■ ■ 32	Relay coil plus +
15	31 ■ ■ 30	
14	29 ■ ■ 28	
13	27 ■ ■ 26	
12	25 ■ ■ 24	
11	23 ■ ■ 22	
10	21 ■ ■ 20	
9	19 ■ ■ 18	
8	17 ■ ■ 16	
7	15 ■ ■ 14	
6	13 ■ ■ 12	See example
5	11 ■ ■ 10	
4	9 ■ ■ 8	
3	7 ■ ■ 6	
2	5 ■ ■ 4	
1	3 ■ ■ 2	
0	1 ■ ■ 0	

View to module front

Module addressing

Basic address setting via DIL-switches:

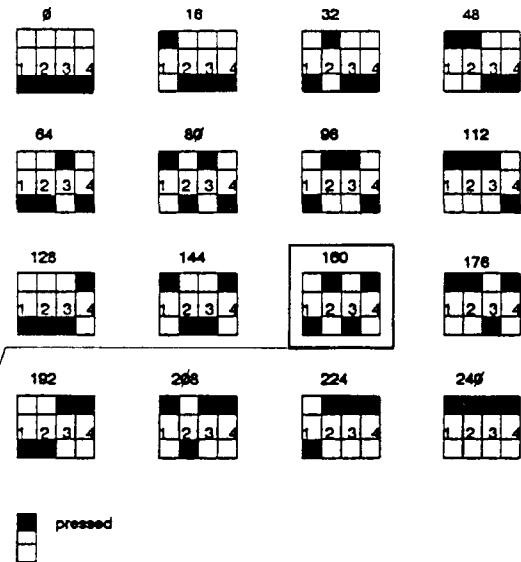

Absolute address =  
basic address + relative address

(Example: A166 = 160 + 6 = core no. 12/13)

Output circuit

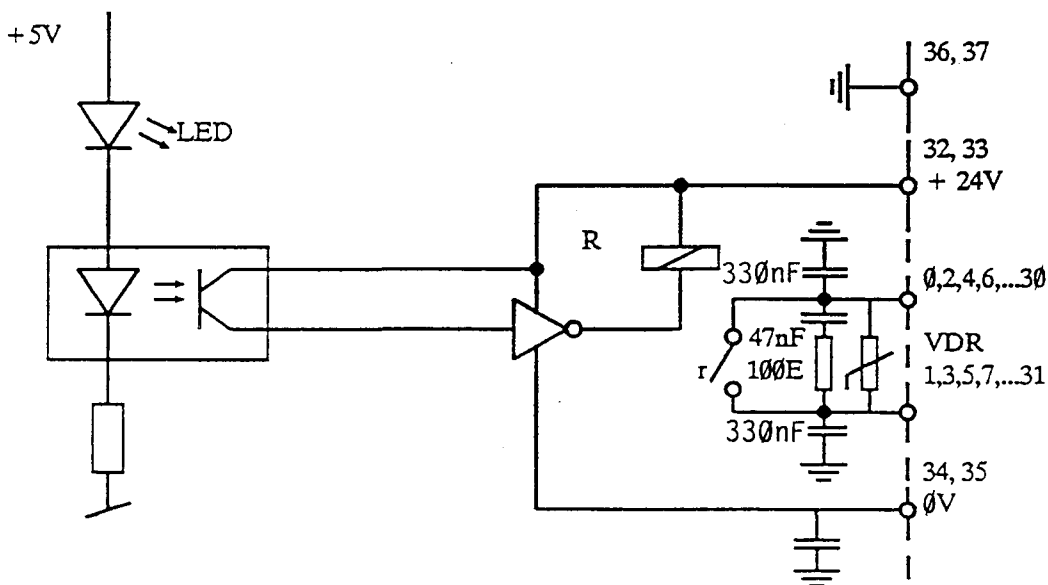



B 1.2.3 Type PCA2.A31 Output module, opto-isolated for 2A

Technical data

Number of outputs per module	16 (subdivided into 4 groups), opto-isolated (between process and CPU)
Output current range	5mA...2A In the voltage range 6...24V the load resistance must be at least 12 Ω.
Operating mode	Source operation (positive switching)
Short-circuit protection	2.5A quick-acting fuse
Voltage range $V_{out}$	6...36VDC
Voltage drop	≤ 1.5V bei 2A
Isolation voltage of optocouplers	min. 2000V
Typical output delay	500µs (i.e. approx. 7 cycles at 70µs)

Presentation

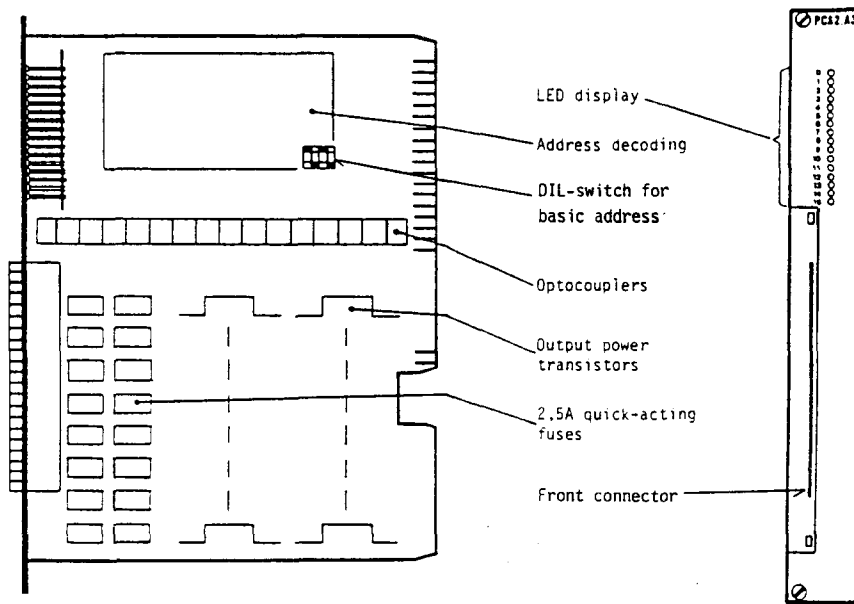

Maximum permissible total current per module

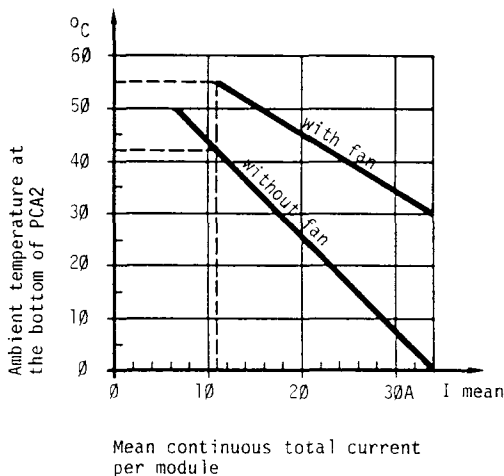

Example: (24VDC)	$I_{mean}$
8 valves at 18W (100% ID)*	6.0A
4 valves at 48W (30% ID)*	2.4A
4 control relays at 12W (100% ID)	2.0A

Mean total current 10.4A

---

Max. ambient temperature:  
 without fan 42°C  
 with fan 55°C

Note: In spite of the internal loop on the positive side (see pin assignment plan), the current per pin is not to exceed 2A.

\*) ID: Duty cycle in %, thermal time constant of the module: approx. 15 min

Division of the galvanically isolated groups

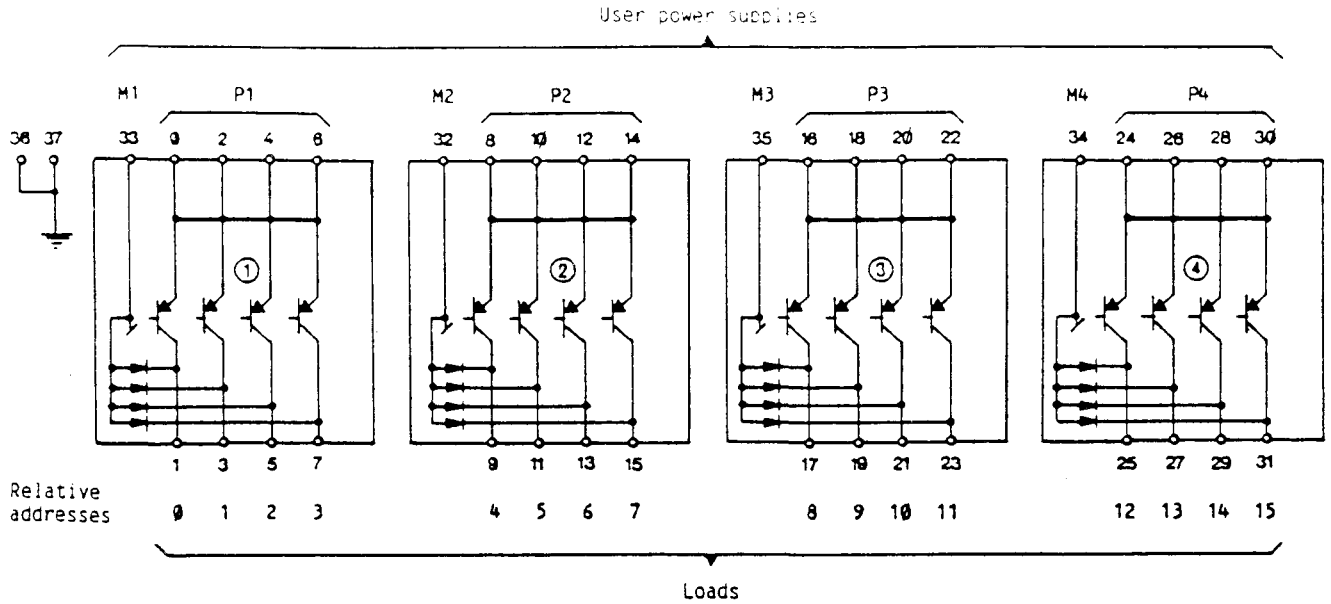

M1, M2, M3, M4: Ground and negative lines of user power supply ①, ②, ③, ④

P1, P2, P3, P4: Positive line of user power supply ①, ②, ③, ④

The output groups are galvanically isolated from each other and from the CPU. Each group can therefore be supplied with different voltages ranging from 6 to 36VDC. It is of course also possible to connect several or all groups to the same voltage source, provided that they can be protected in accordance with the current intensity of the total current.

The 40-wire system cable PCA2.K2.. is required owing to subdivision of the output module into 4 groups.

Output circuit of group ①

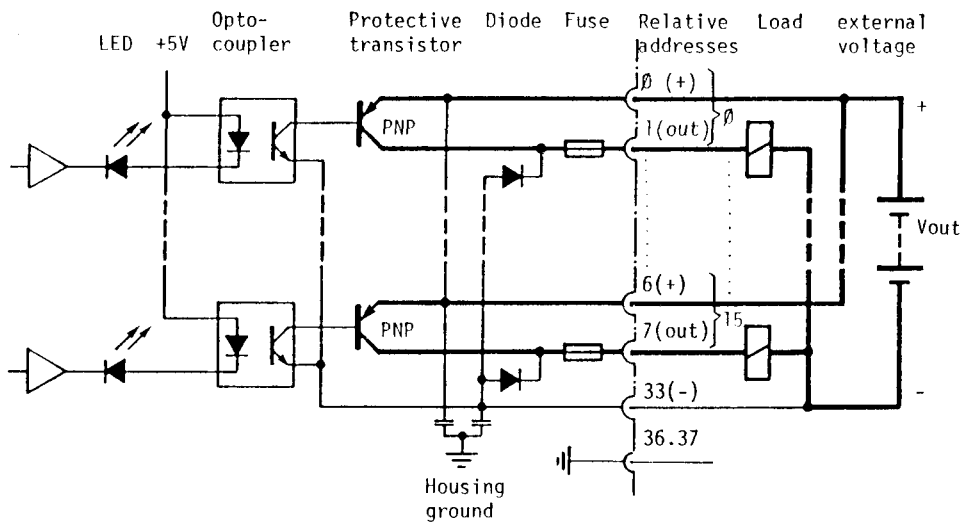

Output conducting (set)      ≙ LED ON  
 Output non-conductive (reset) ≙ LED OFF

Connector pin assignment

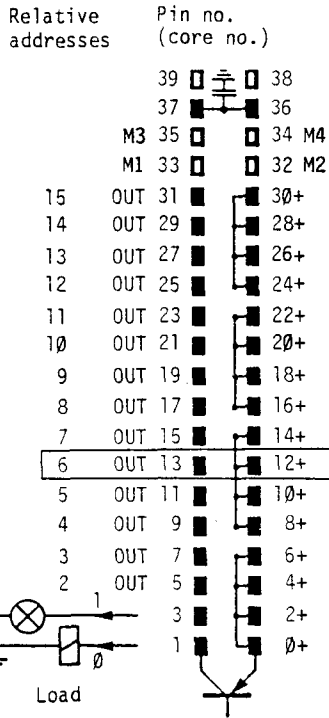

View to module front

Module addressing

Setting the basic address via DIL-switches:

The 40-wire system cable PCA2.K2.. is required for module A31

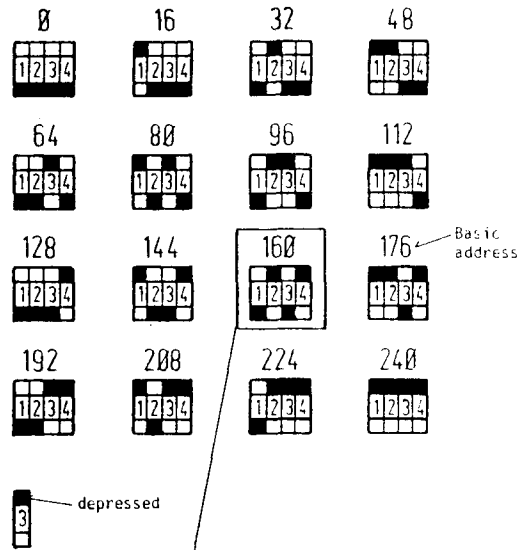

Absolute address =  
basic address + relative address

(Example: A166 = 160 + 6  
cores no. 12/13)

### B 1.2.4 Type PCA2.A40 Output module, electrically connected for 0.5A

#### Technical data

Number of outputs per module	32 (4 x 8) electrically connected
Output current range	5mA...0.5A In the voltage range 5...24VDC, the load resistance must be at least 48Ω.
Operating mode	Source operation (positive switching)
Total current per module	See drawing
Voltage range $V_{out}$	5...32VDC smoothed or pulsating
Voltage drop	1V at 0.5A
Typical output delay	10μs (greater with an inductive load due to free-wheeling diode)

#### Presentation

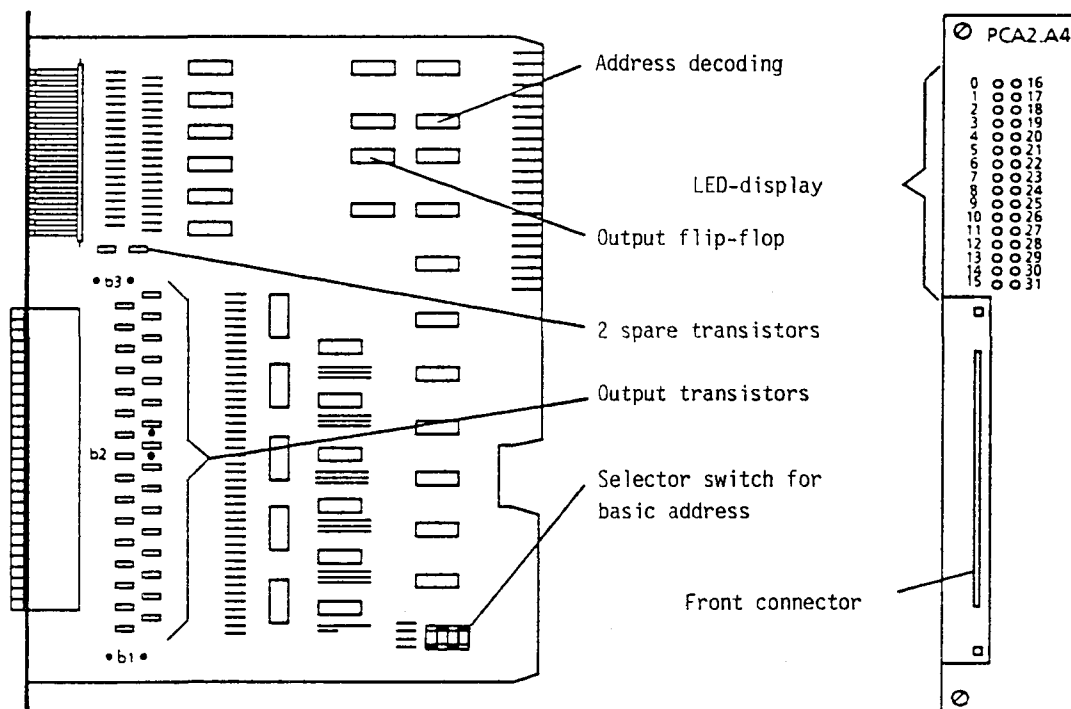

b: Soldering points for locating the positive jumpers (see following page)

## Output circuit

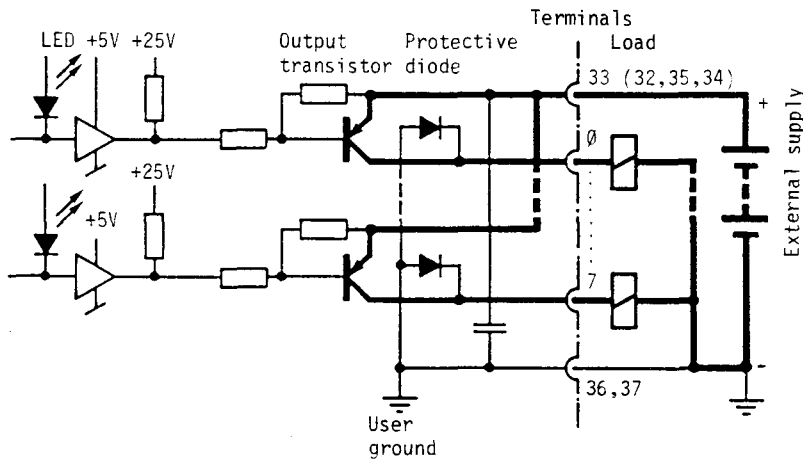

Output conducting (set)  $\hat{=}$  LED ON  
 Output non-conductive (reset)  $\hat{=}$  LED OFF

## Division of the output groups

The outputs are non-isolated and have a common ground, which is connected to the negative of the user circuits (pins 36 and 37).

The division of the outputs into 4 groups (A to D) enable however, up to 4 different user supplies to be connected, which have a common negative, the positive voltages, however, can vary over a range of 5...32VDC.

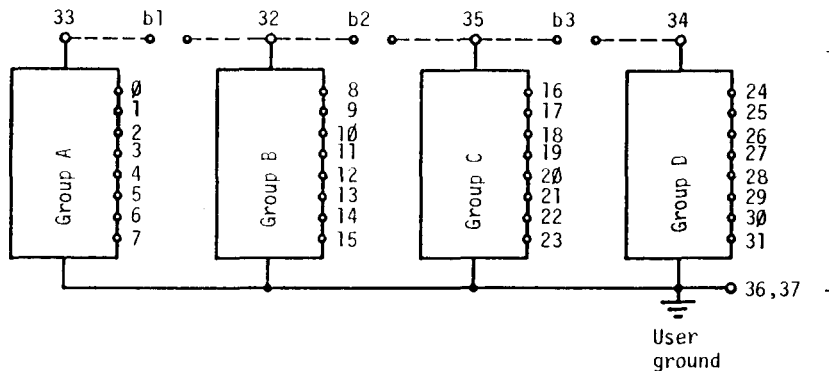

The division of the output module into 4 groups requires the use of the PCA2.K2.. 4 $\emptyset$ -core system cable.

If the total output current of 4A per module is not exceeded and only one supply voltage is applied, it is possible by soldering in the 3 jumpers (b1 - b3) to use the system cable type PCA2.K1..

Connector pin assignment

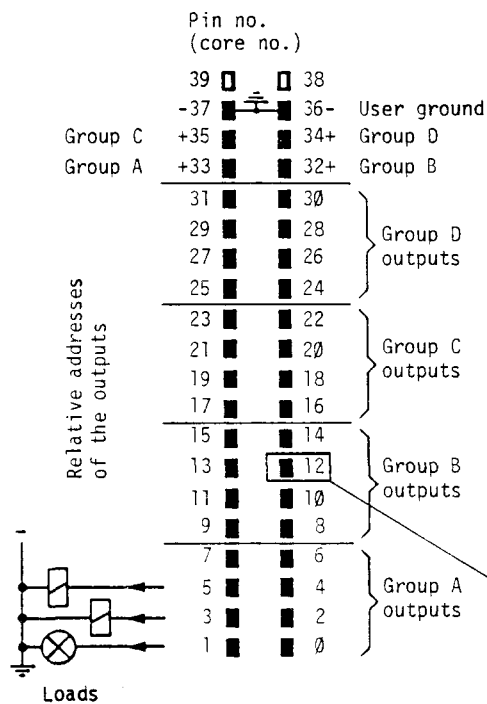

View to module front

Module addressing

Setting the basic address via DIL-switches:

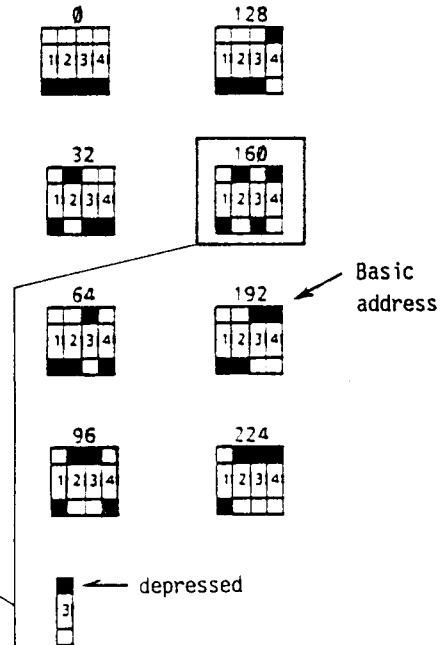

Absolute address of output = basic address + relative address

(Example: A172 = 160 + 12)

Maximum permissible total current per module

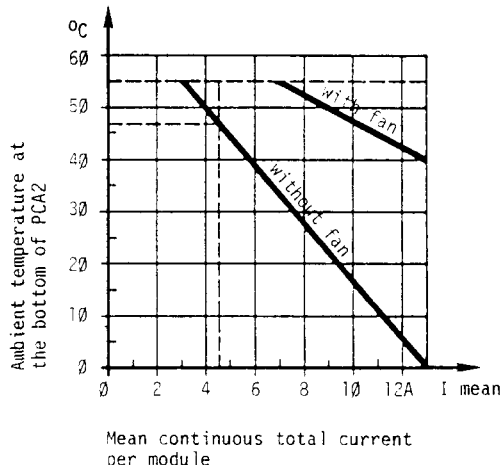

Example: (24VDC)

Component	Power (W)	Duty Cycle (ID)	I mean (A)
16 valves	8W	(50% ID)*	2.7A
8 valves	4W	(100% ID)	1.3A
4 contactors	8W	(30% ID)	0.4A
4 signal lamps	2W	(100% ID)	0.3A
<b>Mean total current</b>			<b>4.7A</b>

Max. ambient temperature:  
 without fan 47°C  
 with fan 55°C

\*) ID: Duty cycle in %, thermal time constant of the module: approx. 15 min.

Spare transistors

The outputs of module PCA2.A40 are not safeguarded. In case an output transistor should become faulty and the user has the necessary skill with a soldering iron, two spare transistors are available on the printed circuit board.

## B 1.3 Analoge Ein- und Ausgangsmodule

### B 1.3.1 Typ PCA2.W1.. Analoge Ein- und Ausgangsmodule 12 Bit

#### Technische Daten

#### Eingänge:

Anzahl Eingangskanäle	8 bzw. 0				
Eingangsschaltung	Differential mit Filter				
Signalbereiche: - Spannung	<table> <tr> <td>1) 0V...+10V oder -10V... 0V</td> <td rowspan="3">} durch Stecker pro Modul wählbar</td> </tr> <tr> <td>2) -5V... +5V                    +5V... -5V</td> </tr> <tr> <td>3) -10V...+10V                    +10V...-10V</td> </tr> </table>	1) 0V...+10V oder -10V... 0V	} durch Stecker pro Modul wählbar	2) -5V... +5V                    +5V... -5V	3) -10V...+10V                    +10V...-10V
1) 0V...+10V oder -10V... 0V	} durch Stecker pro Modul wählbar				
2) -5V... +5V                    +5V... -5V					
3) -10V...+10V                    +10V...-10V					
- Strom	<table> <tr> <td>1) 0...+20mA</td> <td rowspan="3">} alternativ als Stromschleife steckbar. Strombereich ent- sprechend dem oben gewählten Spannungsbereich</td> </tr> <tr> <td>2) -10...+10mA</td> </tr> <tr> <td>3) -20...+20mA</td> </tr> </table>	1) 0...+20mA	} alternativ als Stromschleife steckbar. Strombereich ent- sprechend dem oben gewählten Spannungsbereich	2) -10...+10mA	3) -20...+20mA
1) 0...+20mA	} alternativ als Stromschleife steckbar. Strombereich ent- sprechend dem oben gewählten Spannungsbereich				
2) -10...+10mA					
3) -20...+20mA					
Auflösung	12 Bit = 1/4096				
Genauigkeit (absolute Abweichung)	typ. 0,1% ± 1 LSB*; (max. 0,5% ± 1 LSB bei Bipolar-Betrieb)				
Eingangs-Impedanz	≥ 1MΩ				
Zeitkonstante des Eingangs- filters	0,1ms				
A/D-Umwandlungszeit	≤ 30µs				
Überspannung	geschützt 60VDC / Spitzen 200V				

#### Ausgänge:

Anzahl der Ausgangskanäle	max. 4				
Auflösung	12 Bit = 1/4096				
D/A-Umwandlungszeit	≤ 20 µs				
Signalbereiche					
- Spannung	<table> <tr> <td>0V...+10V ** standard</td> <td rowspan="3">} spezial (mit individuellen Abgleichwiderständen)</td> </tr> <tr> <td>-5V... +5V</td> </tr> <tr> <td>-10V... 0V</td> </tr> </table>	0V...+10V ** standard	} spezial (mit individuellen Abgleichwiderständen)	-5V... +5V	-10V... 0V
0V...+10V ** standard	} spezial (mit individuellen Abgleichwiderständen)				
-5V... +5V					
-10V... 0V					
Genauigkeit	typ. 0,1% ± 1 LSB, max. 0,3% ± 1 LSB				
Ausgangs-Spannungsvermögen	max. + 10,5V inklusiv Kompensationsspannung				
Lastimpedanz	≥ 3kΩ				
- Strom	0...+20mA (nur positiv)				
Genauigkeit	typ. 0,4% ± 1 LSB, max. 1% ± 1 LSB				
Lastimpedanz	0...550Ω (Spannungsvermögen max. 11V)				

\*) LSB: Least Significant Bit; z.B. 1/4096 von 10V: ca. 2,5mV

\*\* ) Zwei Messleitungen kontrollieren bei jedem Kanal die tatsächlich am Lastwiderstand empfangene Spannung (der Spannungsabfall auf der Signalleitung sowie kleine Potentialunterschiede zwischen PLC-Anwendermasse und der Masse am Empfangsort werden dadurch kompensiert).

**Presentation**

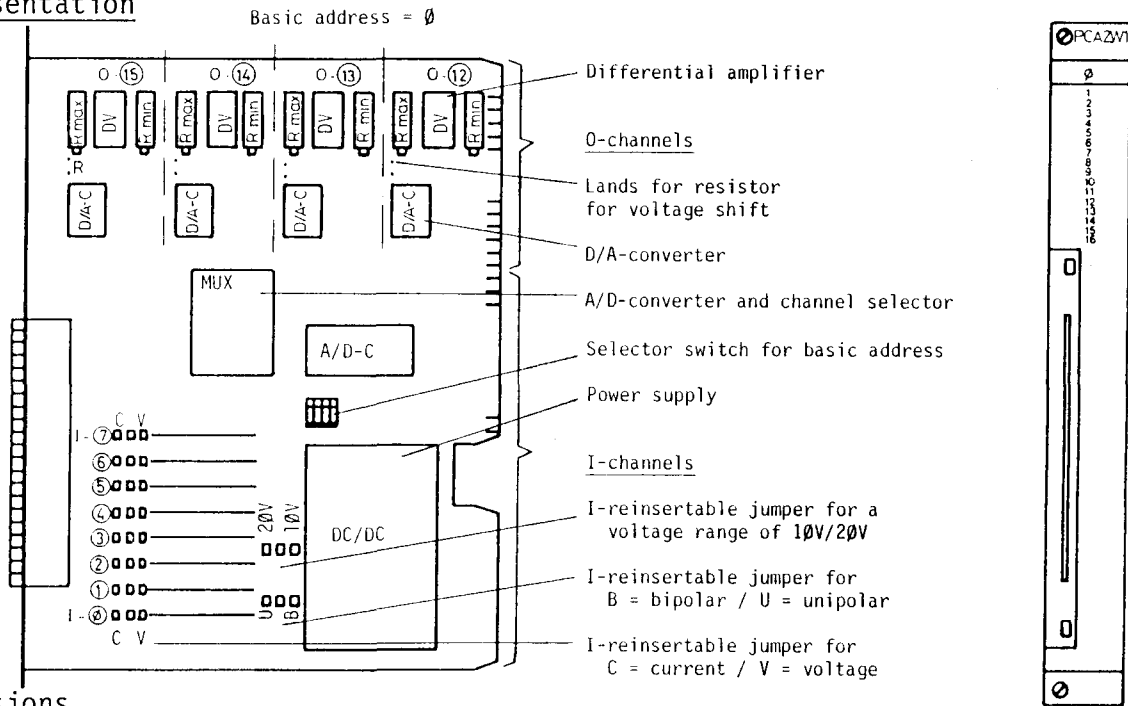

**Versions**

- The analog module can be equipped with the following input resp. output channels:
- Type PCA2.W10 with 8 input channels (without output channels, but they can be added at a later stage)
- Type PCA2.W12 with 8 input channels + 2 output channels (012 and 013)
- Type PCA2.W14 with 8 input channels + 4 output channels
- Type PCA2.W15 (without I) with 4 output channels
- Type PCA2.W16 with 8 input channels (without O, they cannot be added later)

**Connector pin assignment**  
Basic address = 0

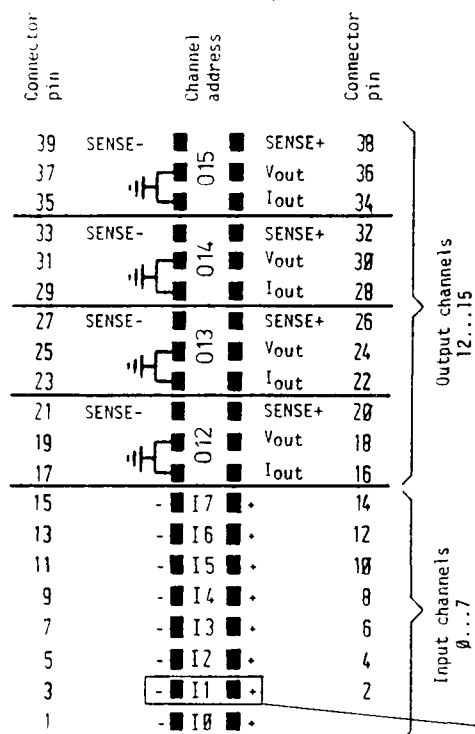

**Addressing of the module**  
Setting of the basic address via selector switch

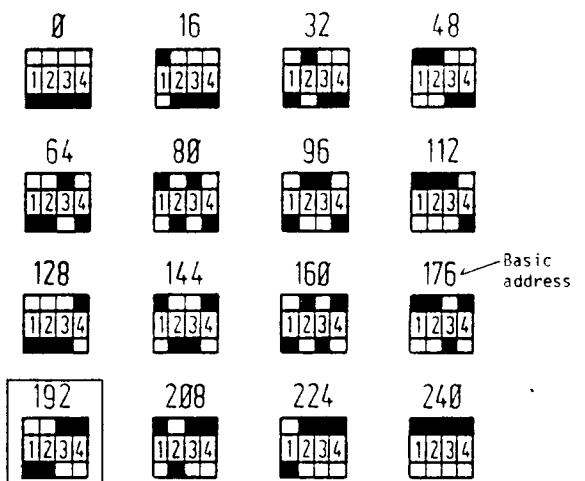

Example:  
Absolute address =  
basic address + relative address  
(193 = 192 + 1)



Block circuit diagram PCA2.W1..  
Basic address = 0

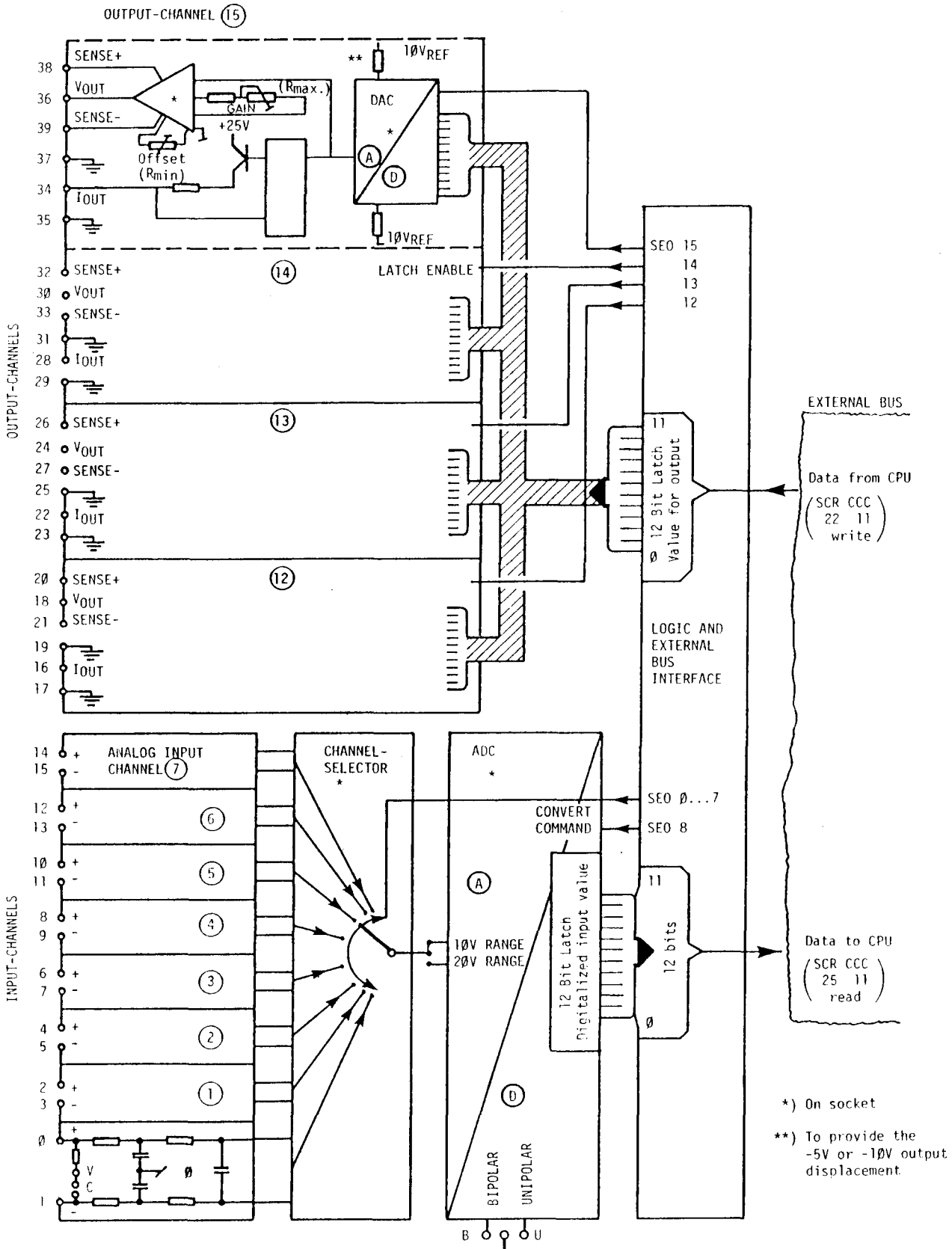

## Software

The operands mentioned in the following examples refer to the basic address 0. The user will convert it according to his application.

### Read in analog value

Two steps are necessary: - select input channel  
- trigger the actual A/D-conversion

The binary value (0...4095) is now available and can easily be transferred to the counter register by means of the instruction set IH.

Example::

SEO 0...7*	; Select input channel (0...7)
SEO 8*	; Trigger A/D-conversion
	; The digital value is available in the
	address range 0 (MSB) to 11 (LSB)
SCR 256	; Load this value into counter 256
25 11*	; 12 bit binary

### Output analog value

The binary value (0...4095) to be output must be available at the inputs of the D/A-converter.

The desired output channel is then selected and the corresponding analog value output. It remains stored until a new command follows.

Example:

SCR 256	→	; counter 256 contains the value to be output (0...4095)
22 11*	→	; supply counter contents of 12 bit to all D/A-converters (0:MSB to 11:LSB) in binary form
SEO 12...15*	→	; select output channel (12...15). The binary value is stored and converted into an analog value in the respective D/A-converter.

### Remark

When selecting an input channel SEO 0...8 also the value being available at the inputs of the D/A-converter will be changed; this does not have a negative effect, however, since no storage command (SEO 12...15) follows.

\*) The basic address selected must be added to these operands.

## Connection to the process

### Connection of the input channels

The common-mode voltage range of all input channels is  $\pm 10\text{V}$ , i.e., both potentials of each input channel must be within  $\pm 10\text{V}$  with respect to the ground in order to allow correct acquisition of the measured data.

### Preselection of the I-ranges:

- The process ground resp. measuring amplifier ground must be connected to the user ground of the PLC.
- The input voltage range of  $10/20\text{V}$  is preselected jointly for all inputs of a module via the connector.
- Whether bipolar voltages ( $\pm\text{V}$ ) or unipolar voltages are to be registered, is preselected jointly for all inputs of a module via the connector B/U.
- Operation with current can be selected for each input individually via the connector (C = current, V = voltage). If the connector is in position C, a precision resistance of  $499\Omega$  is connected to this input circuit, the voltage of which is evaluated. The current range depends on the selected voltage range ( $10\text{V} \hat{=} 20\text{mA}$ ).

The following table shows the three basic ranges with respect to the corresponding binary value:

Binary value	Unipolar (U) operation (connector $10\text{V}$ )	Bipolar operation (B)	
		(connector $10\text{V}$ )	(connector $20\text{V}$ )
4095	+10V (+20mA)	+5V (+10mA)	+10V (+20mA)
2048	+5V (+10mA)	0V (0mA)	0V (0mA)
0	0V (0mA)	-5V (-10mA)	-10V (-20mA)

In case of unipolar operation the positive potential is applied to the plus-terminal. Figures a and b show the connection scheme for the measurement of positive or negative voltages respectively.

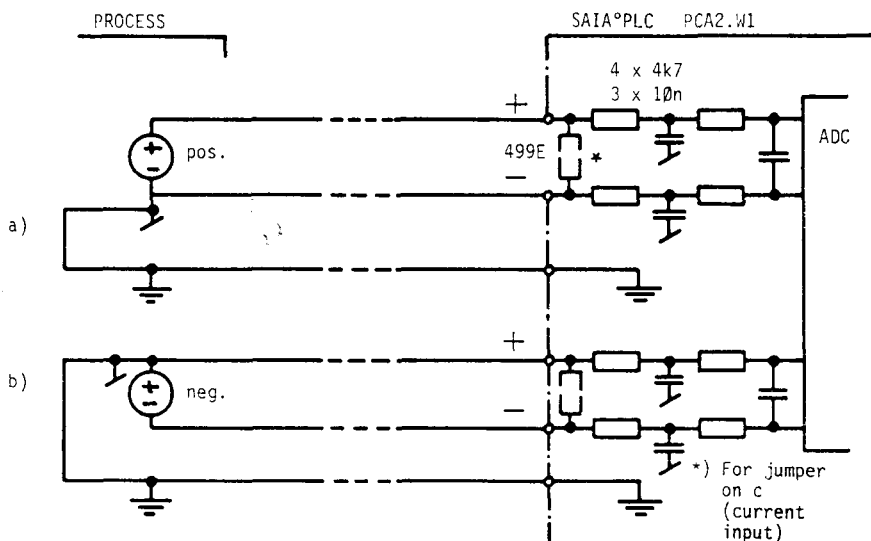

### Output channels

Apart from the number of output channels (0...4) it can also be determined whether it is a current or a voltage output. The ranges of the voltage outputs can also be selected individually.

- For a current output, a D/A converter must be on its socket. The current generator on the pc-board is standard. The current range is 0...+20mA.
- For a voltage output the respective differential amplifier must be inserted in addition to the D/A converter.  
The current output is also available.  
According to the following table, the voltage can be changed by using stable resistors.

The following table contains a summary of the analog output values and the corresponding binary value.

Binary value	Current output	Standard	Voltage outputs	
			with resistor* approx. 20kΩ	with resistor* approx. 10kΩ
4095	+20mA	+10V	+5V	0V
2048	+10mA	+5V	0V	-5V
0	0mA	0V	-5V	-10V

### Connection as current output (figure c):

The current output consists of the D/A-converter and a unipolar power source with high impedance. The voltage of the latter is 11V at 20mA. This corresponds to an external circuit resistance of 0 to 550Ω.

The generated current leaves the PLC with the potential I-out, passes the load and returns to the PLC via the connection process ground - user ground of the PLC. The current does not depend on the external circuit resistance (up to 550Ω) and minor differences in potential of both grounds.

c)

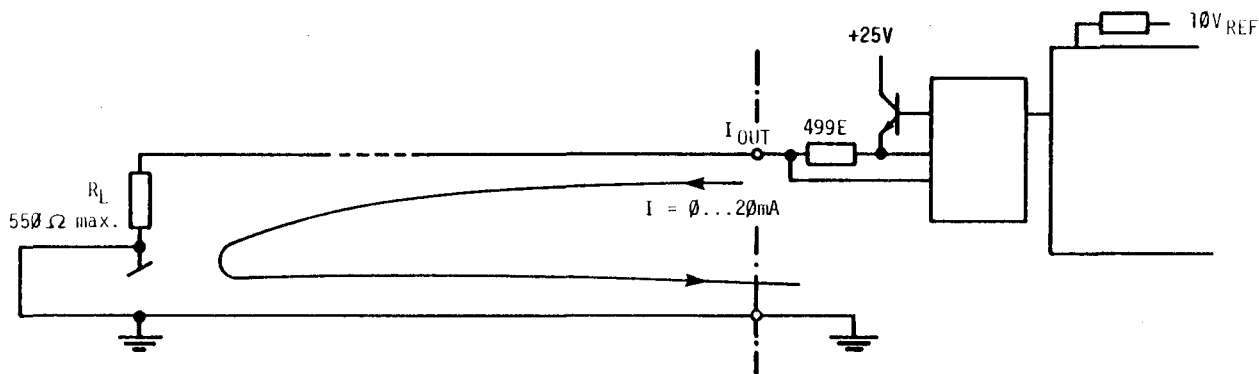

- \*) Due to the technology, the additional resistors must be aligned.  
They may vary from 7 to 21 kΩ or 14 to 42 kΩ respectively.

Connection as voltage output (figure d):

The voltage output consists of the pluggable D/A-converter and the differential amplifier which is also pluggable.

In order to increase the accuracy of the voltage at the load, the two potentials "sense +" and "sense -" are applied. This measuring circuit has a high impedance ( $I \leq 3\mu\text{A}$ ). Wiring according to figure d) has the result that a voltage loss in the circuit V-out and minor differences in potential between the process ground and the PLC-ground is automatically compensated for (output voltage =  $10.5\text{V}$ ).

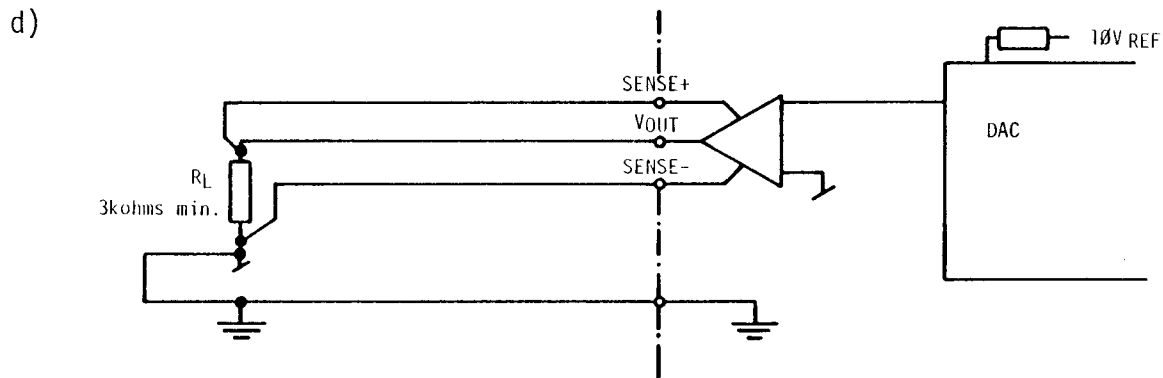

### B 1.3.2 Type PCA2.W2.. Analog input module with 8-bit resolution

#### Technical data

Number of input channels	16 or 32
Voltage range	0...10V <sup>1)</sup>
Resolution	8 bits ( $1/256 \approx 0.4\%$ )
Accuracy	1 1/2 Bit $\approx 0.6\%$
Static input impedance	$\geq 1M\Omega$
Time constant of the I-filter	0.2ms
A/D-conversion time	$< 100\mu s$
Current consumption	5V: 36mA, 25V: 4mA (average)

#### Presentation

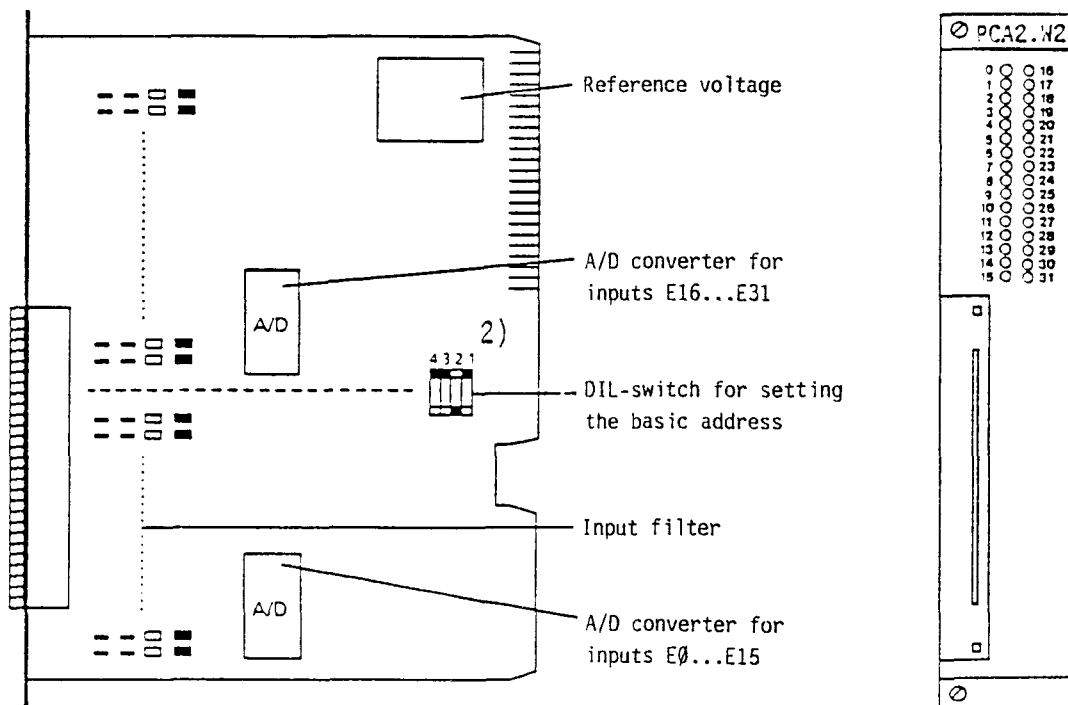

- 1) Special variants 0...5V or 0...20mA (see chapter "Versions").
- 2) The on/off setting on the DIL-switch is reversed in comparison to usual modules.

Versions

Two standard versions are available:

Type PCA2.W20 with 16 I-channels, 0...10V

Type PCA2.W25 with 32 I-channels, 0...10V

Special versions (available on request)

Type PCA2.W21 with 16 I-channels, 0...5V

Type PCA2.W22 with 16 I-channels, 0...20mA

Type PCA2.W26 with 32 I-channels, 0...5V

Type PCA2.W27 with 32 I-channels, 0...20mA

Connector pin assignment

Basic address = 0

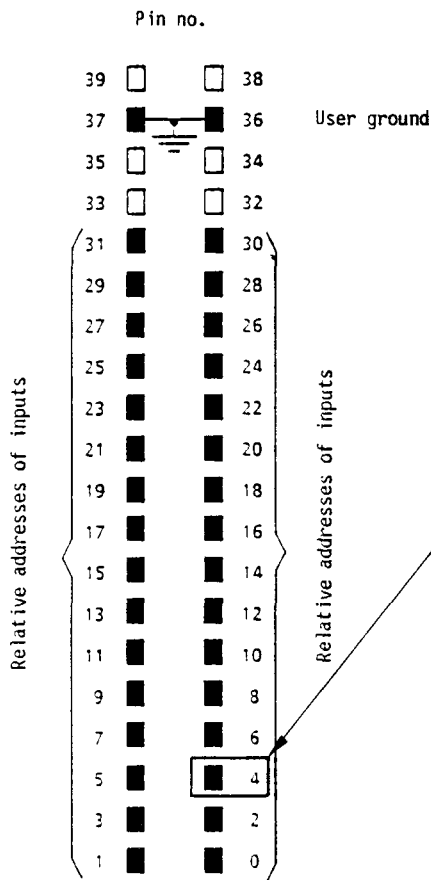

View to module front

Module addressing

Setting of the basic address on the DIL-switch:

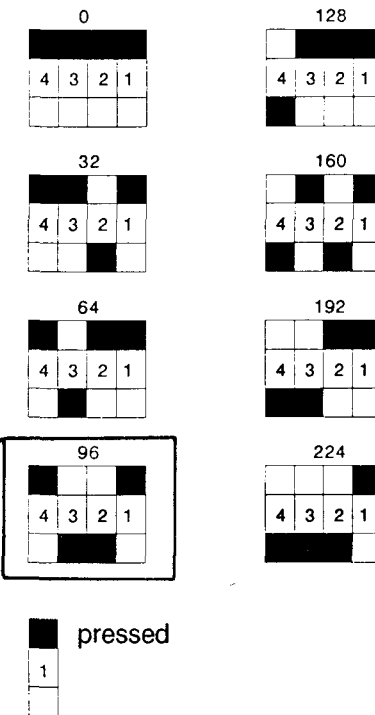

The on/off setting on the DIL-switch is reversed in comparison to usual modules

Absolute address of the input channel = basic address + relative address

(Example: E100 = 96 + 4)

## Block circuit diagram PCA2.W2..

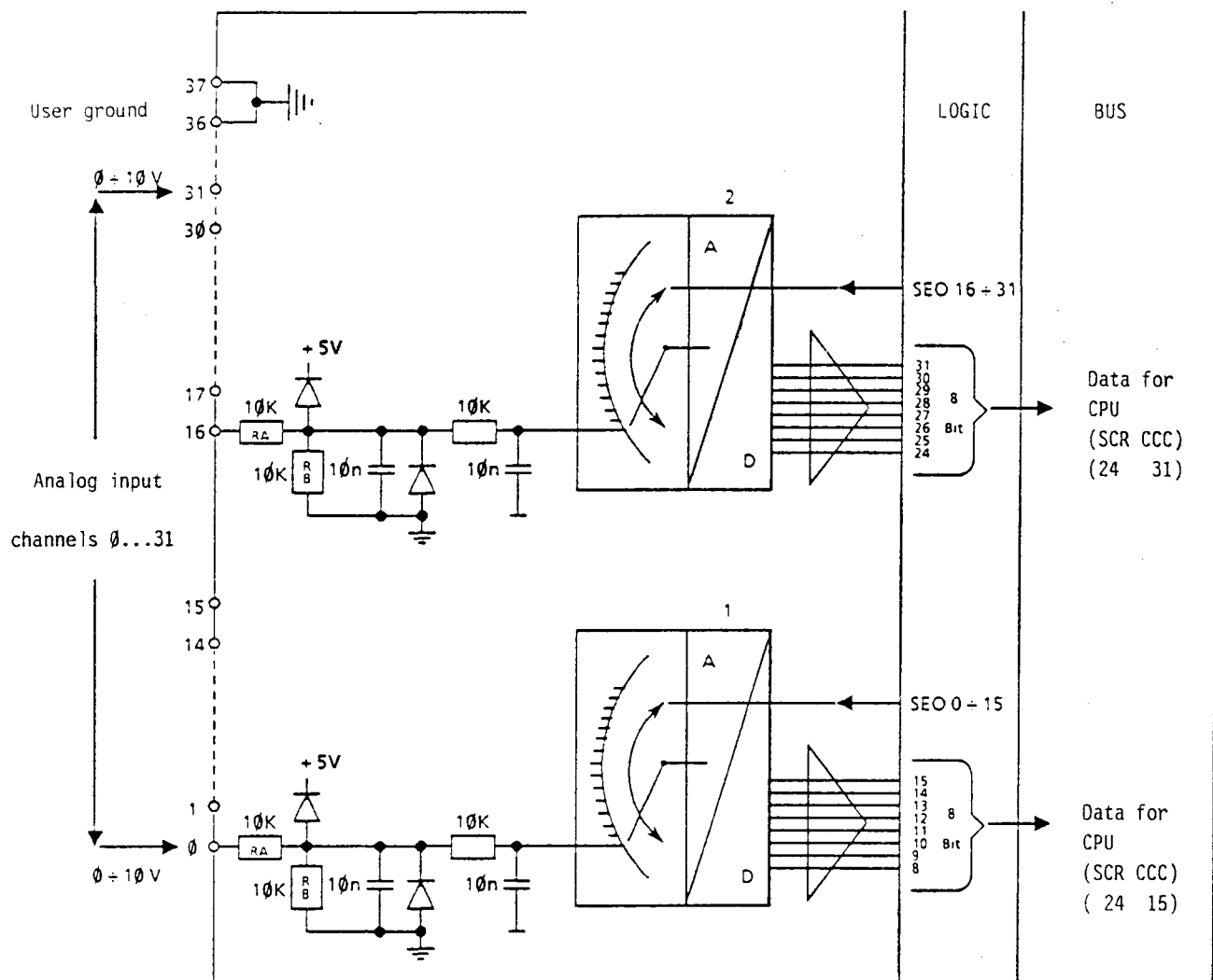

The block circuit diagram is applicable to type PCA2.W25 with 32 input channels, 0...10V. For type PCA2.W20 with 16 input channels, E16...E31 and the A/D-converter 2 are not provided.

The following changes must be made for the input ranges 0...5V or 0...20mA respectively:

Input range	$R_A$	$R_B$	
0...10V	10 K 1 o/oo	10 K 1 o/oo	} Special
0... 5V	10 K 5%	$\infty$	
0...20mA	470 5%	2490 1 o/oo	

Special versions available on request.



### Overview of binary value/analog value

Binary value	Standard $\emptyset \dots 10V$	Special	
		$\emptyset \dots 5V$	$\emptyset \dots 20mA$
255	+10V	+5V	20mA
128	+5V	+2.5V	10mA
$\emptyset$	$\emptyset V$	$\emptyset$	$\emptyset$

### Software

An analog value is read in according to the following steps:

- select input channel
- read in value and store (8 bits)

The input to be read is selected with the instruction SE0 n (n = channel number + basic address) by means of a pulse and an analog/digital conversion is triggered. The converted binary value can then be transferred into a counter or flag field.

### Example (for software level 1H)

The basic address of the module is  $\emptyset$ . The values of the input channels 2 and 18 have to be transferred to the counters C288 or C289 respectively.

```
(SEA   $\emptyset$ )
SEO   2 1) } ; Select input channel 2
SCR   288 2) ; Transfer binary value to C288
      24 15 1) ; (the value is in the address field 8 (MSB)
                to 15 (LSB) 1)
```

```
SEO   18 1) } ; Select input channel 18
SCR   289 2) ; Transfer binary value to C289
      24 31 1) ; (the value is in the address field 24 (MSB)
                to 31 (LSB) 1)
```

- 1) For a basic address other than  $\emptyset$ , the basic address must be added to this operand.
- 2) When using older modules, these program parts should be listed twice for safety reasons.

B 1.4 Type PCA2.H1.. Counter module for 10...200kHz

The detailed manual is available in German or English and consists of about 60 pages. It also contains the software modules and practical application examples.

The software modules may also be used as macros for the SAIA<sup>®</sup>PCA-assembler. Please contact our selling agency.

Type PCA2.H10 Basic module (rapid counter and stepping motor control)

Type PCA2.H11 Additional counting mode module

Type PCA2.H13 Additional step motor module with 1 channel (with acceleration and deceleration ramp)

Type PCA2.H12 Additional step motor module with 2 channels

Presentation

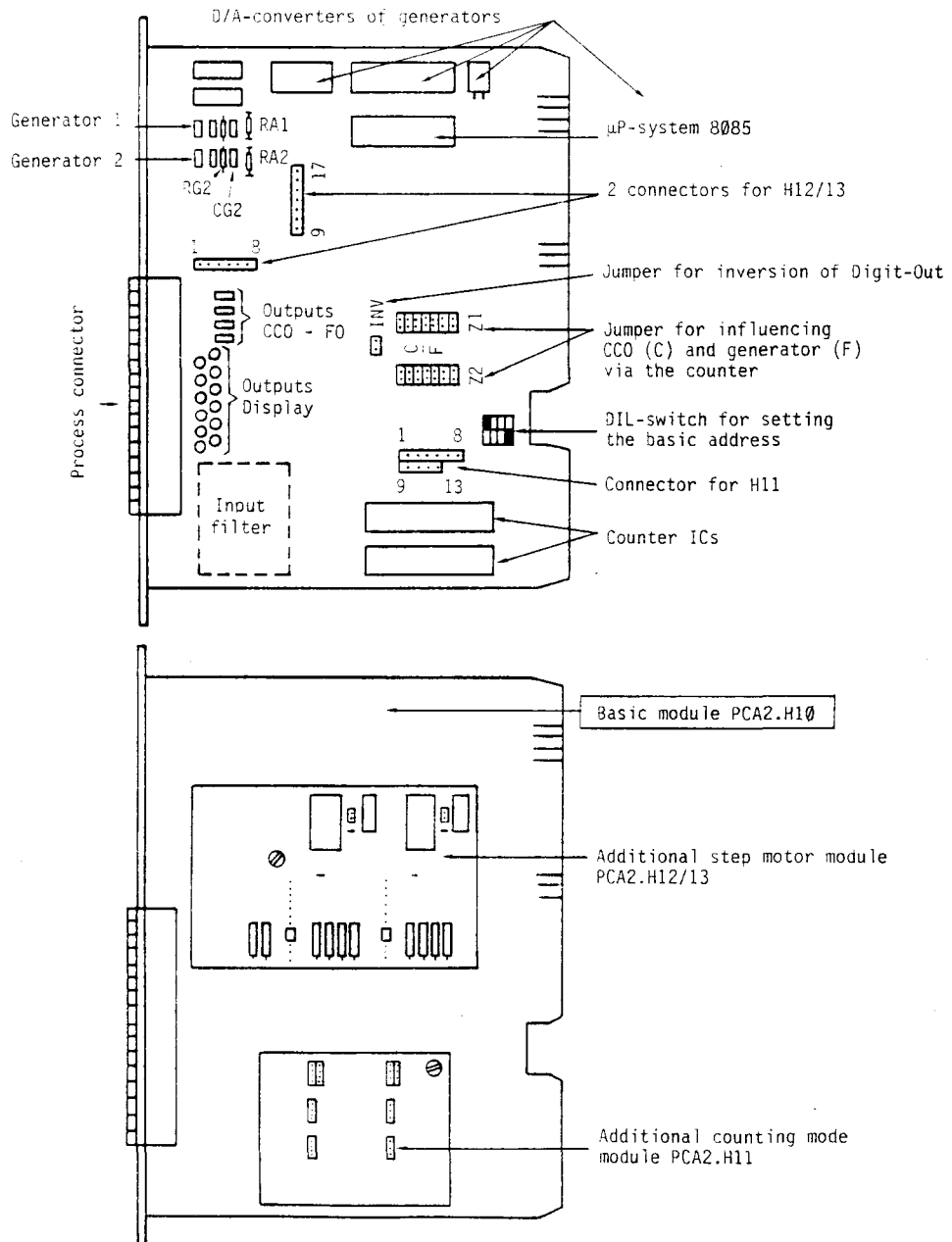

### B 1.4.1 Type PCA2.H1.. Counter module

#### Introduction

The registration of signals quickly following one another by means of the standard SAIA®PLC input modules is limited to a frequency of 50 - 100 Hz. On the one hand, this limit is determined by the interference suppression filters of these inputs (typ. 8ms) and on the other hand by the CPU-cycle time in conjunction with the user program. The counter module PCA2.H1.. for processing faster pulse sequences with frequencies up to 200 kHz is now on offer.

As evident from the following description, the counter module is extremely versatile. Together with two additional modules it allows the following basic functions in two independent systems:

- Rapid counter up to a maximum of 200 kHz (without input filter)
- Incrementing up/decrementing down to the preselected value, 6 digits
- Decrementing to zero
- Incrementing/decrementing with recognition of the sense of rotation (decoder)
- Output of programmable frequencies up to 50 kHz
- External display of the counter reading
- Step motor control (clock) with adjustable acceleration and deceleration ramp
- Combination of various functions in the same module

#### Fields of application:

- Measuring and counting of pulses up to a frequency of 200kHz  
Examples: Pulse generator for velocity, number of revolutions, flow-rate, number of parts, digital measurement of length
- Recognition of the sense of rotation of two-channel incremental shaft encoders  
Example: Positioning by means of a DC-motor with a pulse generator flanged to it
- Step motor control  
Example: Positioning of X-Y-tables, palletizing devices, handling robots

The module PCA2.H1.. has the same dimensions as the I/O-modules. It uses 16 element addresses of the PCA2. The counter module can be operated by means of all CPUs. The module is connected to the process via the 40-pole plug at the front. The counter module always features two systems which are independent of each other.

The basic module PCA2.H10 contains the counter and the generator. An additional counting mode module PCA2.H11 and/or an additional step motor module PCA2.H12/13 can be attached to the basic module.

As is evident from the block circuit diagram which will be shown later, the counter consists in the main of the actual counter, a preselection register and a comparator of counter and register. These 3 circuits are contained in a complex integrated circuit (TC 5070).

Counting and comparing is effected on the counter module itself and not in the user or system programs of the PLC. Moreover, a fast counter output (CCO) is directly influenced by the counter which results in the fast reaction necessary for counting frequencies up to 200kHz. A microprocessor system (8085) assumes the function of administration and coordination between counter module and CPU.

Counter and register are influenced (loaded, cleared) via the user program of the PLC. In addition, various states of counter and register (0, equal), as well as logic states of elements can be interrogated and influenced via the user program. The respective contents of the counter can be displayed on an external display via the process plug or read into the CPU for processing via the user program.

As mentioned above, the basic module also contains a generator the frequency of which is selected or changed via the user program. The generator can be connected to the counter in order to output a number of pulses predetermined in the register or counter. The generator signal can be registered at the process plug.

On the one hand, the attachable additional counting mode module serves as a phase decoder for decoding the signals of optical angle encoders. Pulses are generated from the dephased signals and the sense of rotation is determined according to which the counter increments or decrements. On the other hand, the pulses of two pulse generators (UP and DOWN) can be processed.

As the name indicates, the step motor module serves to control step motors and due to a high-performance acceleration and deceleration automatics far beyond their start/stop-frequency. The step motor module is connected to the generator of the basic module. The number of steps which the motor has to execute is entered into the counter or the register. The maximum step frequency is supplied to the generator. The start/stop-frequency as well as the ramp slope of acceleration and deceleration is adjusted via a few potentiometers on the step motor module. Now the motor must only be supplied with the start signal and it will execute the steps within an optimal time independent of the PLC system or user program.

The output signal of the step motor module is a one-phase signal. Coding and amplification is effected in the external control electronics of the respective step motor.

It must be mentioned again that the counter module with all its additional modules functions a u t o n o m o u s l y. The user program serves only to supply the module with the information what to do, how and when.

However, it has to be considered that the entire counter module (systems 1 and 2) is to be dealt with only in a single parallel program.

Hardware

Block circuit diagram of the counter module PCA2.H1..

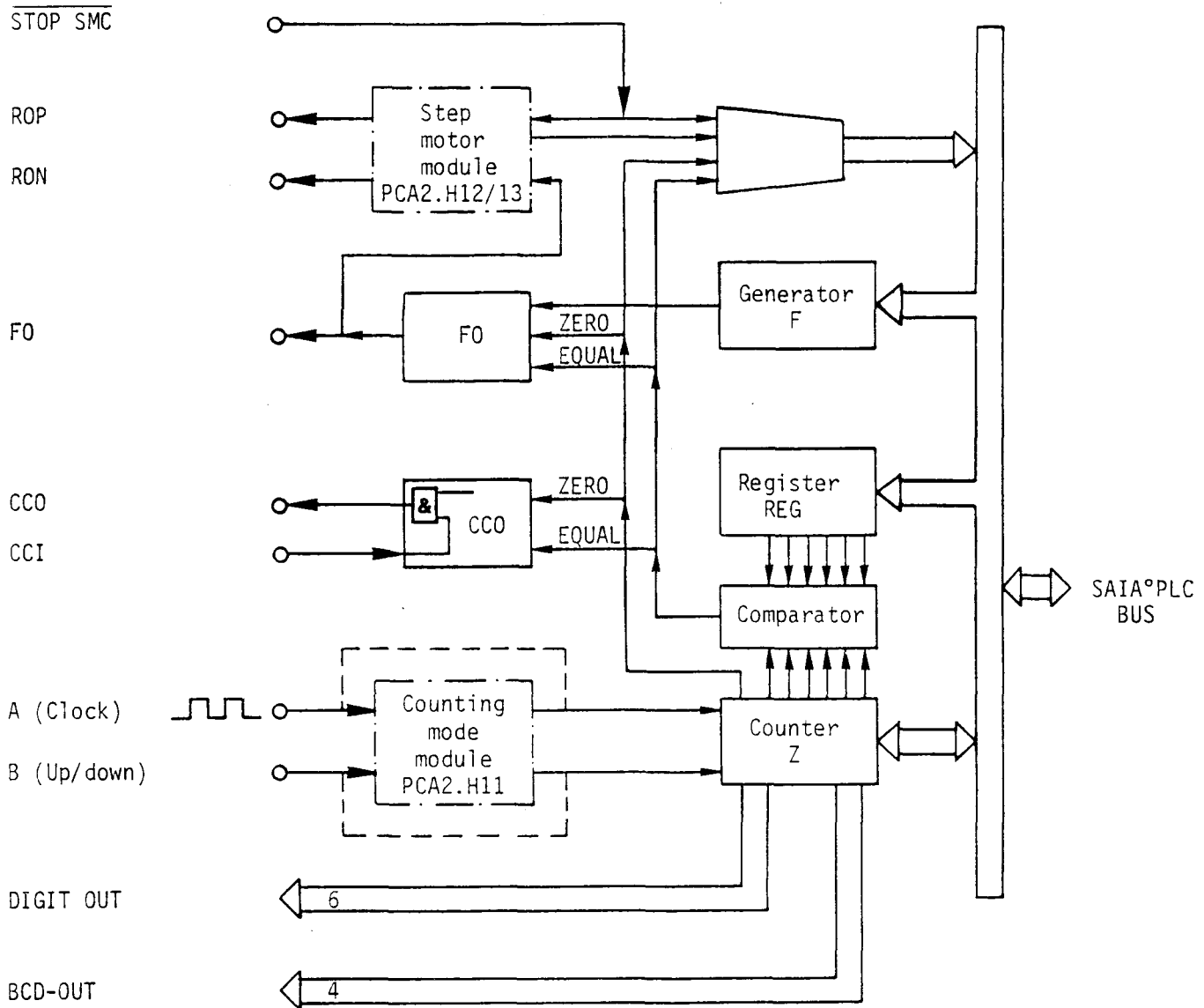

ROP = Ramped Output Positive  
 RON = Ramped Output Negative  
 FO = Frequency Output (generator output)  
 CCO = Counter Controlled Output  
 (direct counter output)  
 CCI = Counter Controlled Input  
 (AND-connected to CCO)  
 SMC = Step Motor Control

S1/S2 = Entire system  
 F1/F2 = Generator  
 REG 1/2 = Register  
 Z1/Z2 = Counter

Connector pin assignment of the counter module (view to module front)

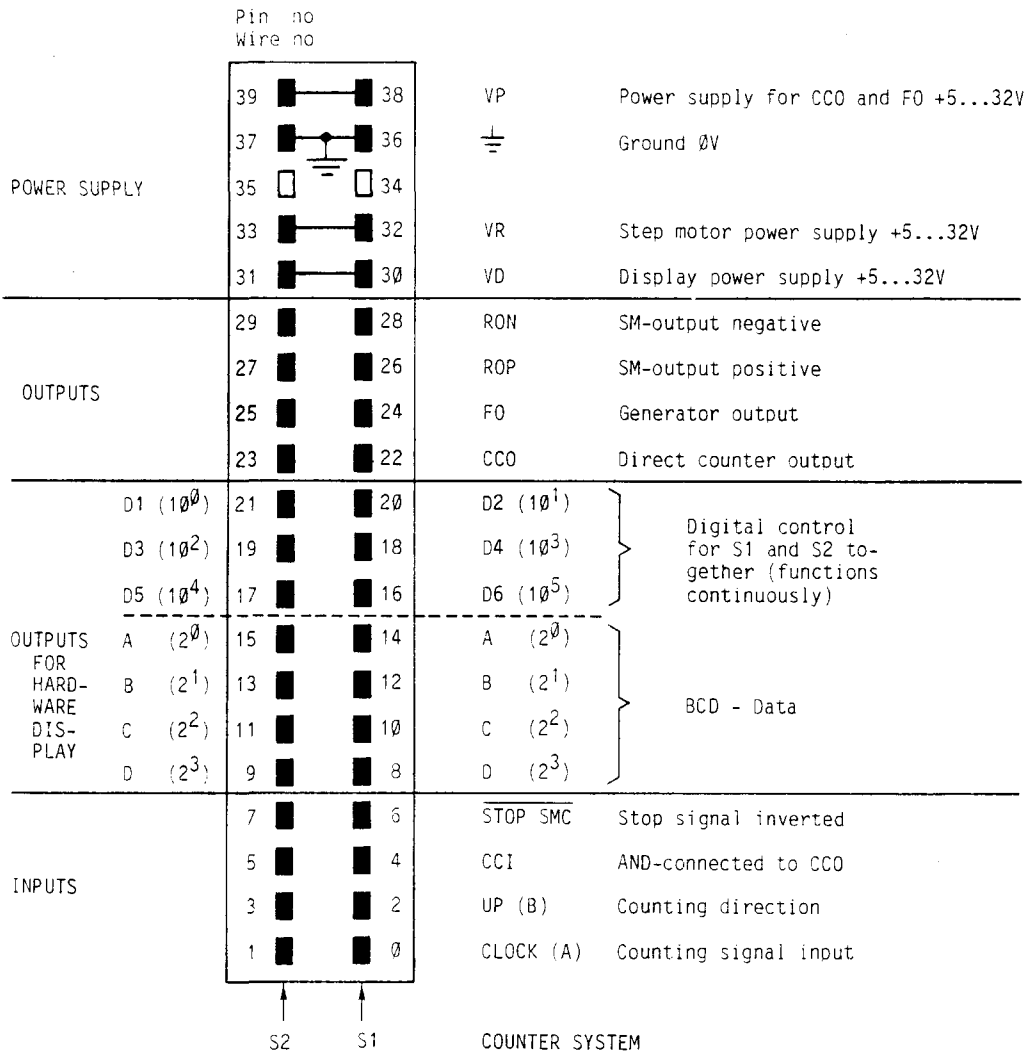

Module assignment: Setting of the basic address via DIL-switch:

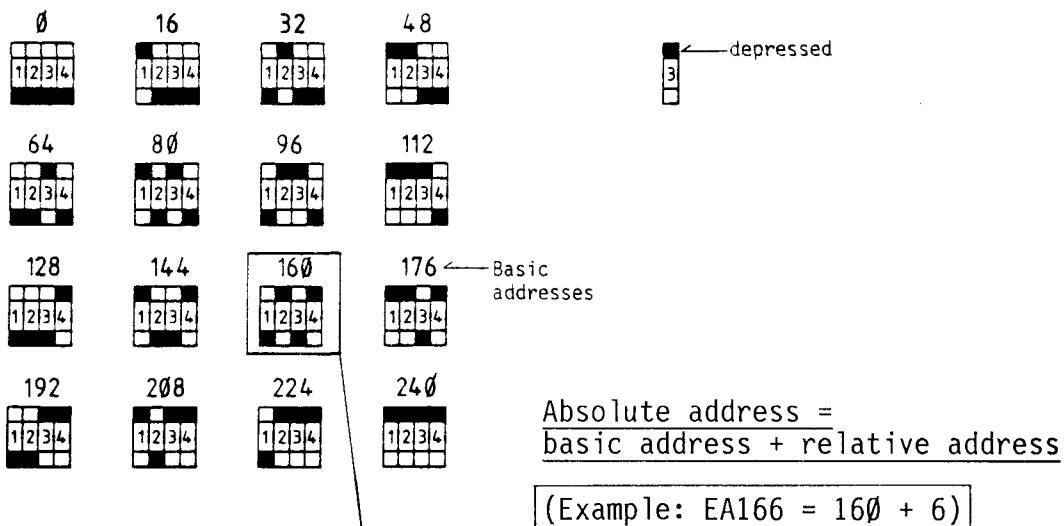

Technical dataCounter (Z)

Number of systems	2 (i.e.: all functions listed in the following are present in double and consequently independent of each other)
Counting frequency	standard: 10kHz max.: 200 kHz by adapting or leaving out the input filter
Number of decades	6
Storage of data	registers of the counter module are volatile, but data can be saved in non-volatile PLC-registers
Counting direction	forward, backward
Counter = register	selectable via jumper to pos. "C-C=R" (EQUAL) (CCO - counter = register)
Counter = 0	selectable via jumper to pos. "C-C=0" (ZERO) (CCO - counter = 0)
Direct counter output	1 (CCO = Counter Controlled Output) Switch on via user program Switch off in case of EQUAL or ZERO
Display of the counter contents	via 10 outputs - 4 BCD-out, 6 digit-out (for external power supply) Both systems share the 6 digit-out outputs
Inputs	Clock (A) Up/down (B) H = up; L = down min. 50µs ("H")  Rising edges are decisive
	CCI (Counter Controlled Input) AND-connected to CCO STOP SMC (for step motor control) all inputs may have a source voltage of 24V, 10mA* L = 0...+4V, H = +19...+32V* Input delay 50µs

\*) Smoothed DC-voltage

Outputs	<p>CCO and FO (Frequency Output) + switching, 5...32V, 500mA*</p> <p>Load resistor: 5...24V: min. 48Ω</p> <p>BCD-out and digit-out + switching, 10...32V, 100mA* 5...10V, 50mA*</p> <p>Load resistor: 10...24V: min. 240Ω 5...10V: min. 200Ω</p>
Power supply VP	for outputs CCO and FO 5...32V smoothed (or pulsating for CCO)
Power supply VD	for the outputs of the display 5...32V smoothed (permissible ripple content depends on the data of the displays in use)
Power supply VR	for step motor control output ROP + switching, 5...32V, 500mA Load resistor: 5...24V: min. 48Ω
	if output RON is used, the power source is directly connected to the load and VR is not used - switching, 5...32V, 100mA Load resistor: 5...24V: min. 240Ω
Element addresses used	16 (total for both systems)
Load counter/register	via user program - from elements (I, O, M, H) - from CPU counters (Cn) - from word register (Rn)
Read counter contents	via user program - to elements (I, O, M, H) - to CPU counters (Cn) - to word registers (Rn)

---

\*) Smoothed DC-voltage



Generator (F)

Frequency	Standard: $f_{max} = 10\text{kHz} \pm 5\%$ Special: by changing the capacitor CG and/or the resistance RG $f_{max}$ ranges from a few Hz to 50kHz
	Exact adjustment can be achieved by soldering in a balancing resistor RA
Signal	Symmetric square wave signal
Frequency selection	via the user program $f_{max}$ can be subdivided into 255 steps (1...255) (8 bits)
Start generator	via the user program
Stop generator	via the user program or by means of the counter depending on the position of the jumper "F-C=R" (EQUAL) (Frequency-Counter = Register) or "F-C=0" (ZERO) (Frequency-Counter = 0)
Single pulse	via the user program to output FO (Frequency-Output) Pulse length approx. 50 $\mu$ s

### B 1.4.2 Type PCA2.H11 Additional counting mode module

As an additional module it can be attached to the counter card PCA2.H10 and secured by means of a screw, after removing the bridging plug from the counter card.

Number of channels	2
Modes	- Phase decoder (M1) - UP/DOWN-mode (M2) can be selected by changing the position of a jumper
Phase decoder	2 phases to the inputs A and B
Mode "x 4"	1 impulse per edge A and B
Mode "x 2"	1 impulse per edge of A
Mode "x 1"	1 impulse per cycle
UP/DOWN-mode	signals at A count up signals at B count down signals arriving simultaneously (within one sampling pulse) are suppressed
Sampling frequency	200kHz
Counting frequency	in mode M1 min. 50kHz in mode M2 min. 100kHz

### B 1.4.3 Type PCA2.H12/H13 Additional step motor module

It can be attached to the counter card PCA2.H10 and secured by means of a screw as an additional module.

Number of channels                    1: PCA2.H13  
    2: PCA2.H12

Parameters adjustable via 5 potentiometers (10-turn) each:

P1: max. step frequency            The max. step frequency is supplied by the internal generator ( $F_{out}$ ). P1 serves for adjustment of the synchronisation range of the module PLL-circuit of the module oscillator.

P2: Start/stop frequency           adjustable between 50 and 500Hz

P3: Ramp slope                      adjustable 1 : 20  
Basic value can be determined by soldering in a capacitor  
Standard: 1µF ---> min. slope: 10kHz/s

P4: Ramp symmetry                  ratio 1 : 5 to 5 : 1

P5: Pulse length                    adjustable from 10...85µs for ROP/RON

#### Module inputs

$F_{out}$                                     signal from generator

STOP SMC (Step Motor Control)    Reset of SMC-circuit and switch off ROP/RON via process plug

RESET SMC                            like STOP SMC, but via the user program

#### Module outputs

ROP (Ramped Output Positive)    + switching pulse output to the process plug  
5...32V (VR) 500mA

RON (Ramped Output Negative)    - switching pulse output to the process plug  
5...32V (VR) 100mA

RAMP READY                          can be interrogated in the user program during pulse output ---> "L"

## B 1.5 Type PCA2.F20 Data line switching module for processor module M22 and M32

### Application

The module PCA2.F20 allows connecting 4 peripherals which are fitted with a serial interface of the RS 232c-type or a 20mA-current loop.

Via the DATA LINES of the CPU PCA2.M32\* data can be exchanged between the SAIA°PLC and these units. Message and control lines allow establishing a connection from or to the respective peripheral unit. Remote transmission via modem is also possible with the data line switching module F20.

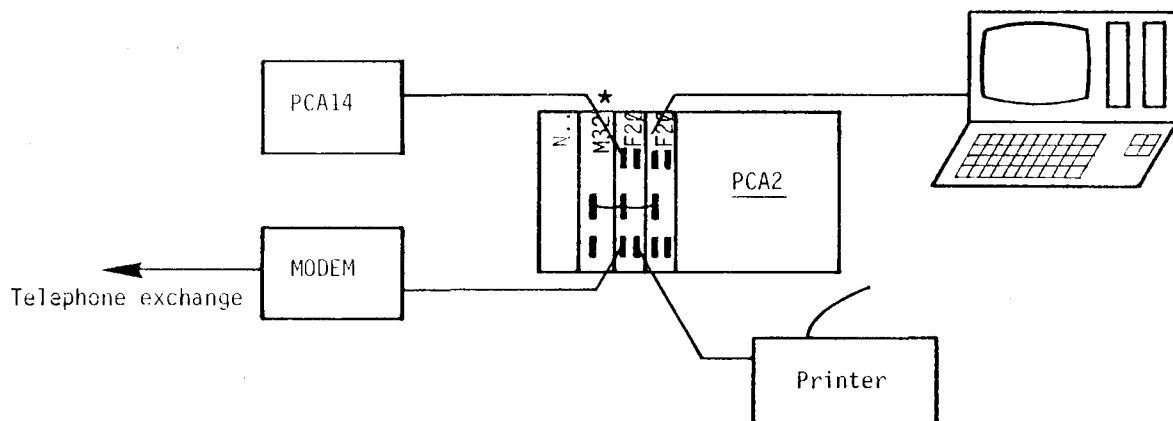

PCA2.N..	PCA2.M32 *	PCA2.F2	PCA2.F2
	☀	⋮	⋮
	○ CPU RUN	○ 0	○ 1
	○ ERROR	○ 0	○ 1
	DATA LINES	DATA LINES	DATA LINES
	PGU	2 3	2 3

- \*) The data line switching module can be used for the following CPUs:  
 PCA2.M31, M32 and M22.  
 Only M32 will be referred to in the following.  
 For one CPU 1 to 4 F20-modules can be employed, i.e. communication is possible with a maximum of 16 peripherals.

Technical data

Number of peripheral interfaces	4, active or passive
Type of interface	RS 232c or 20mA-current loop, selectable individually
Used addresses	8, the basic address is set with DIL-switches
Data transfer	The data transfer is performed between the CPU PCA2.M32 and the connected peripherals via PCA2.F20
Management of the peripheral interfaces	With SEL 0...3 selection of the peripheral interfaces by means of the user program with the aid of the control and status signals
Number of control and status signals per peripheral interface	2 CTS (Clear to Send) RTS (Request to Send)
Transmission speed	100 baud to max. 9600 baud*, defined in the software with the PAS 100-instruction
Peripheral connector	25-pin miniature connector, male (for details refer to "Connector pin assignment")
Power consumption	5V: 480mA (max.) 25V: 45mA + 50mA per active current loop
Number of modules per rack	max. 4 (standard: 1 or 2)

---

\*) In order to obtain high baud rates, the user program must be organised correspondingly (short logic operations).

Presentation

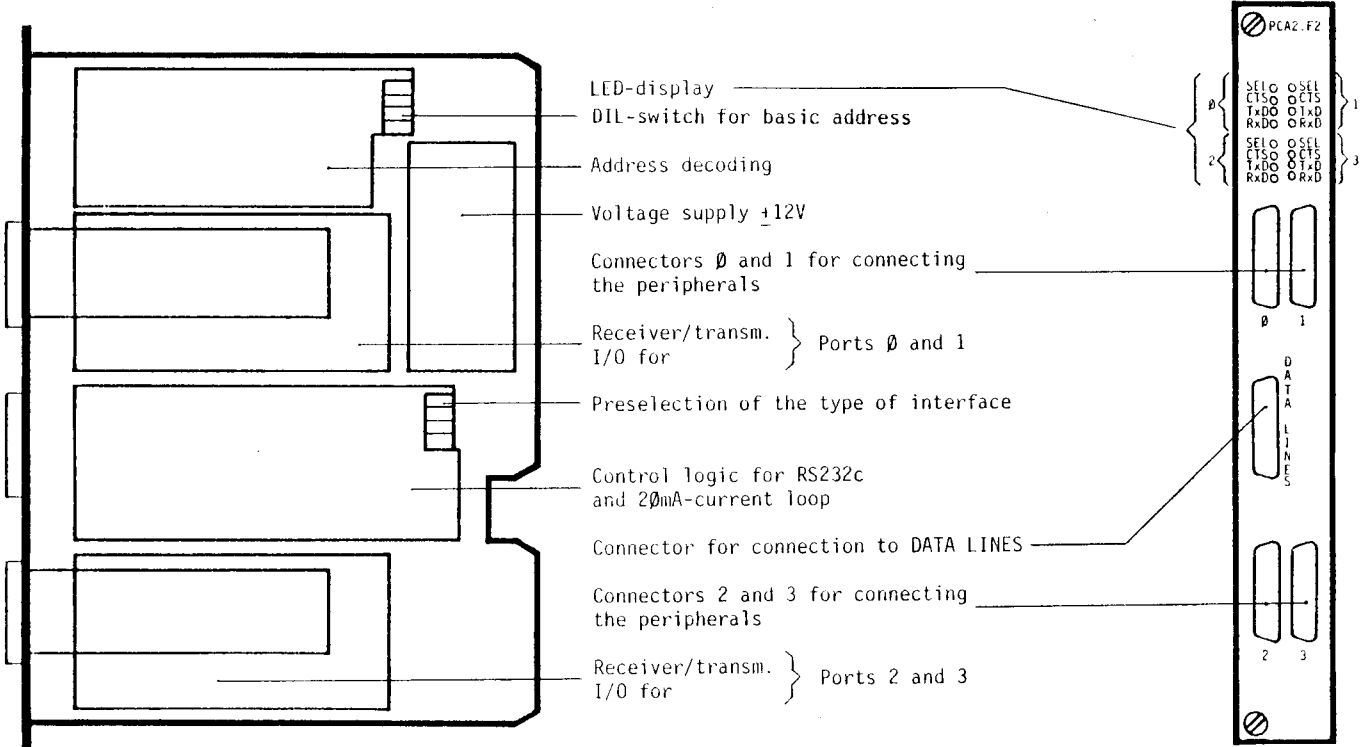

Addressing of the module

The module uses 8 addresses. As a result, addressing is performed in steps of 8 using 5 DIL-switches.

0, 8, 16, 24, 32, ....., 240, 248

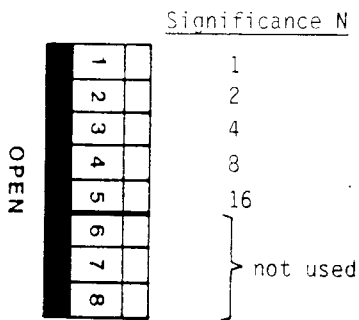

The basic address (BA) is calculated as follows:

$$BA = N \cdot 8; \quad N = \frac{BA}{8}$$

The binary value N is set with the DIL-switches 1...5.

Example for basic address 56

$$N = \frac{56}{8} = 7$$

Setting of the DIL-switches:

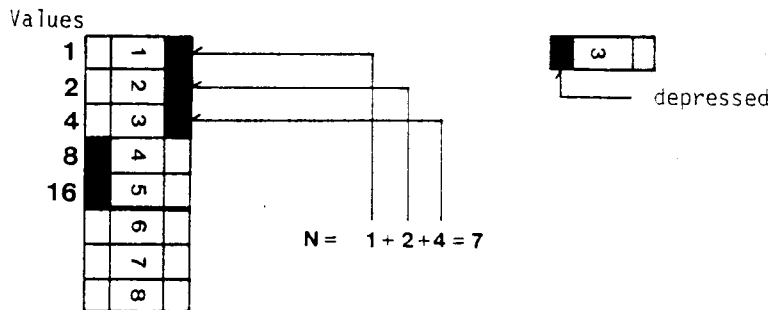

Block circuit diagram PCA2.F20

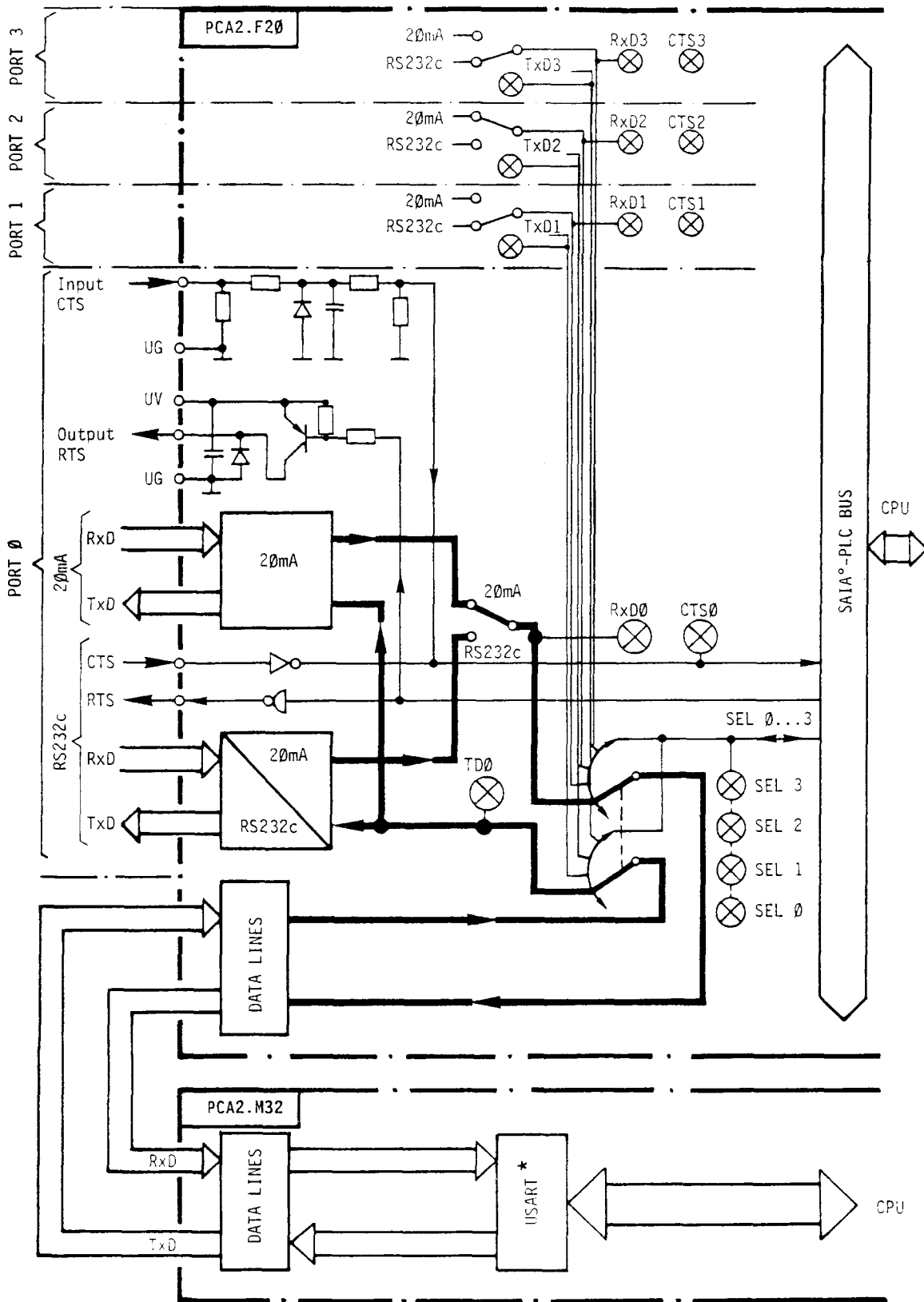

\*) USART: Universal Synchronous Asynchronous Receiver Transmitter

Selection of the interfaces 20mA or RS 232c

For each of the 4 peripheral connectors the desired type of interface can be selected. The setting is performed with the fourfold DIP-switch.

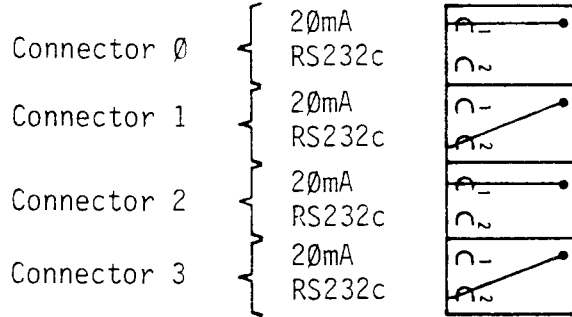

With this setting only the line "Received data" (RxD) is switched. The lines "Transmitted data" (TxD) function simultaneously with both interfaces (see block circuit diagram).

"DATA LINES" connection between PCA2.F20 and PCA2.M32

For this connection the interface of the CPU PCA2.M32 must be active (see chapter Hardware M22 and M32).

Connection of one module PCA2.F20:

Scheme

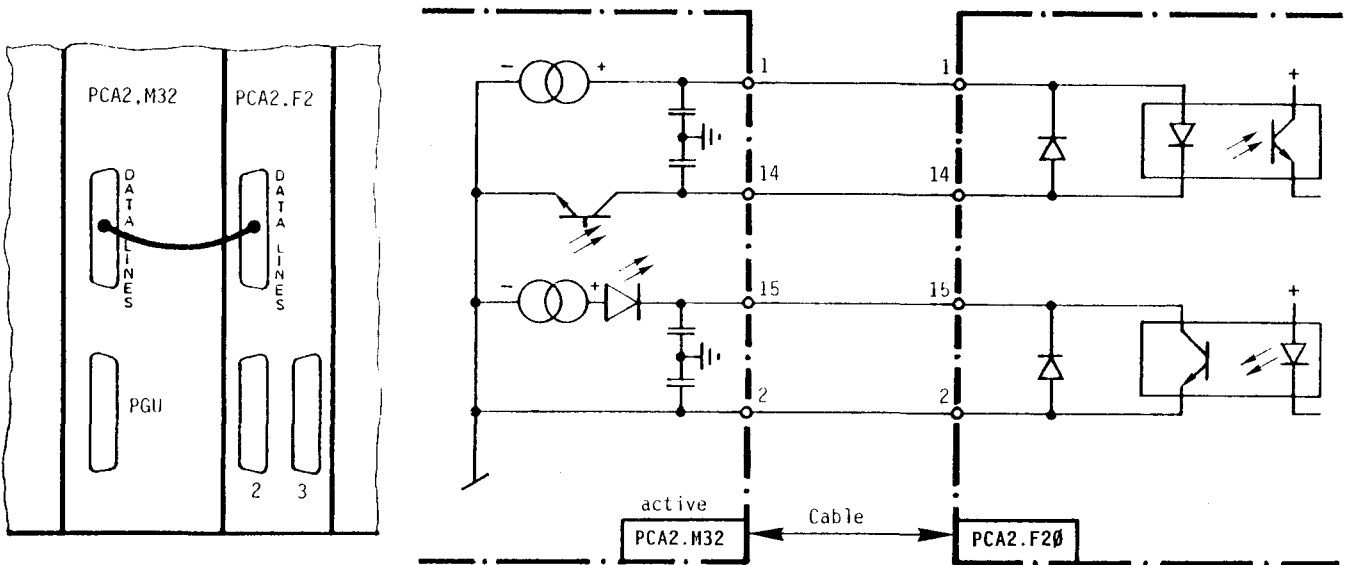



Connection of several modules PCA2.F20  
(max. 4):

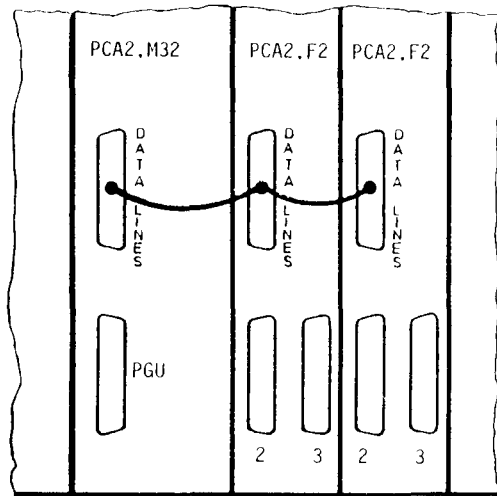

Scheme (for 2 modules PCA2.F20)

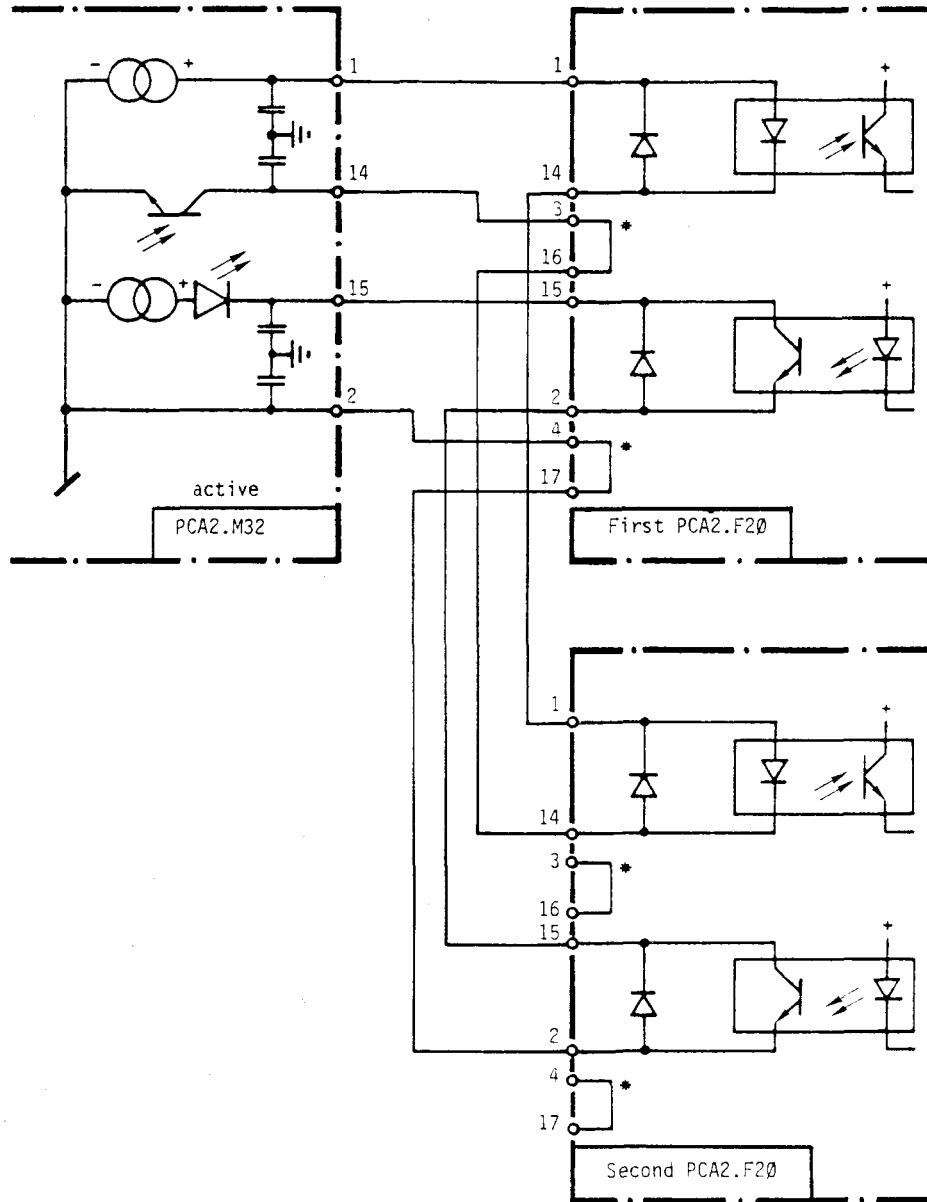

\*) These jumpers are integrated in the module PCA2.F20 and serve for cabling in case several data line switching modules are used.

### Address assignment and function of the signals

The four peripheral interfaces must be managed via the user program. In order to ensure this, 1 status signal and 1 control signal, which can be set or read in the user program, are available for each connector.

#### Address assignment

Address	Signal designation	Treatment
0	SEL 0	} settable and readable
1	SEL 1	
2	SEL 2	
3	SEL 3	
4	RTS 0 CTS 0	only settable only readable
5	RTS 1 CTS 1	only settable only readable
6	RTS 2 CTS 2	only settable only readable
7	RTS 3 CTS 3	only settable only readable

#### Function of the signals

SEL 0...3 (Select) With the instruction SEO SEL 0...3 the data lines (TxD, RxD) of the respective peripheral connector 0...3 are connected to the DATA LINES of the CPU.

With the read commands (e.g. STH SEL 0...3) it can be determined which peripheral connector was connected to DATA LINES.

RTS 0...3 (Request to Send) With the instruction SEO RTS 0...3 the respective peripheral unit can be informed that the connection to DATA LINES has been established.

CTS 0...3 (Clear to Send) With the read commands (e.g. STH CTS 0...3) it can be determined that a peripheral unit needs to be connected to DATA LINES.

Similar to the input/output module PCA1.B90 the control signal RTS and the status signal CTS use the same address. Consequently, one signal can only be set, the other one can only be read (see also "Address assignment").

### Meaning of the LEDs

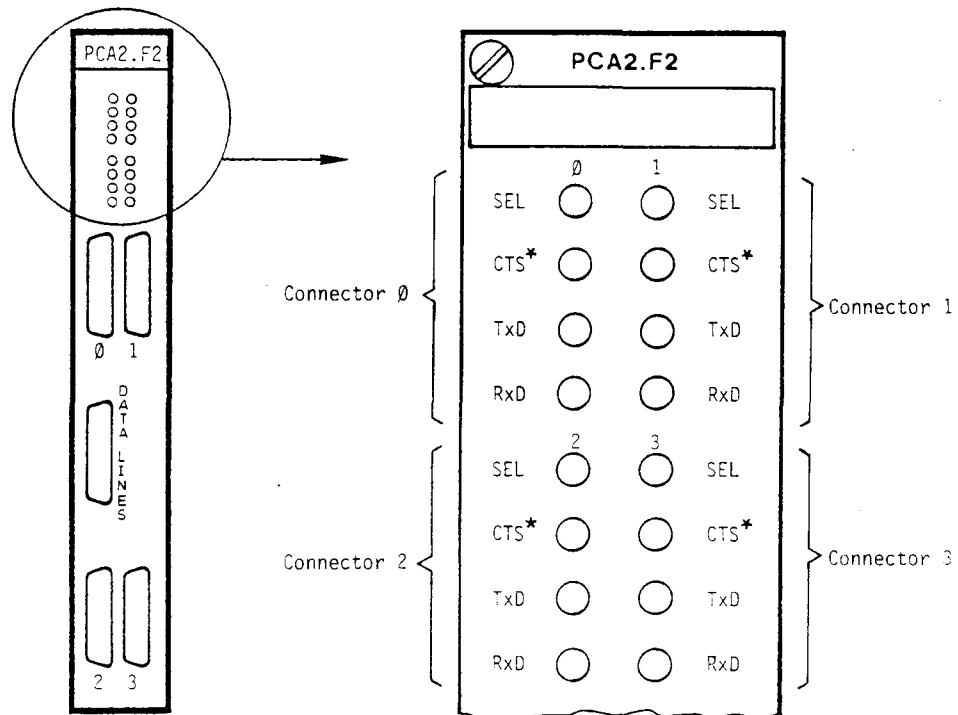

- SEL (Select): OFF-state: 0  
The transmit and receive line of the corresponding connector are separated from DATA LINES. Data transfer is not possible.
- ON-state: 1  
The connection between the respective peripheral unit and DATA LINES is established. Data transfer is possible.
- CTS (Clear to Send)\*: OFF-state: 0  
State of rest. The connected peripheral unit does not need to be connected to DATA LINES.
- ON-state: 1  
The respective peripheral unit needs to be connected to DATA LINES.
- TxD (Transmit Data): LED flashes, when data is transmitted from the CPU to the respective peripheral unit.
- RxD (Receive Data): LED flashes, when the module PCA2.F20 receives data from the respective peripheral unit. The reception of data is always indicated, even when the respective connector is not connected to DATA LINES.

Depending on the baud rate and the telegram length only a short flash or a long flickering of the LEDs "TxD" and "RxD" can be recognized.

\*) The first modules PCA2.F20 still use the designation REQ (Request).

### Interface RS 232c (to peripheral units)

If the interface RS 232c is selected, the data lines as well as the control and message lines of the PCA2.F20 correspond to the recommendation RS 232 as regards the function and electric level or they correspond to DIN standard 66020:

Signal level of the data lines:	"L": +12V "H": -12V
Signal level of the control and message lines:	"L": -12V "H": +12V

### Pin assignment according to RS 232c

Pin no.	Abbreviation	Signal name	Direction of the signal	
			Periph.	PLC
1	PGN	Protective Ground		
2	TxD	Transmitted Data	←	
3	RxD	Received Data		→
4	RTS	Request to Send	←	
5	CTS	Clear to Send		→
7	SGN	Signal Ground		

### Connecting cable for RS 232c-interface (to the peripheral units)

The standardized guidelines hold true for laying the cable, i.e. screened cable with a max. length of 15m (not in the same cable duct as the power cables).

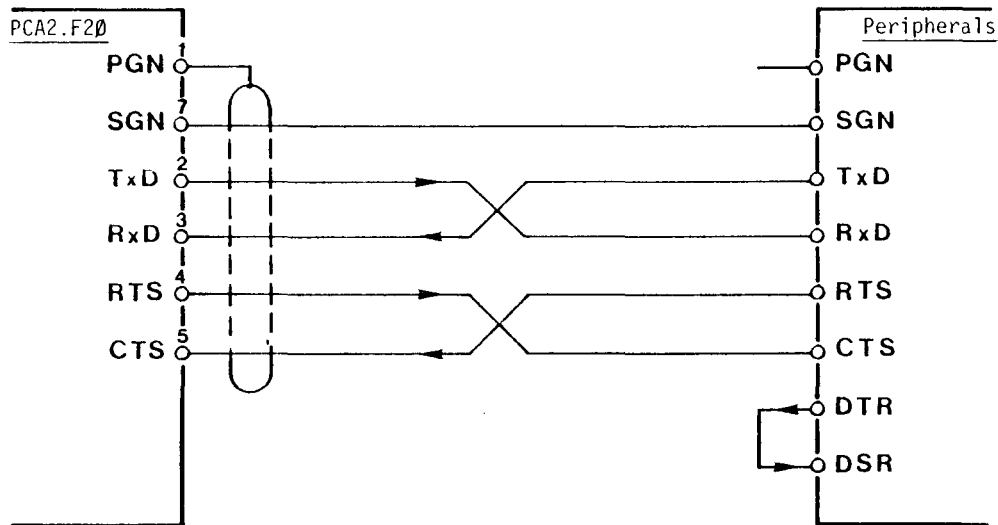

With many peripheral units fitted with RS 232c-interfaces the signals

- DTR (Data Terminal Ready)
- DSR (Data Set Ready)

can be found, too.

In the case of the PCA2.F20 they are always assumed to be in the ON-state. For the peripheral unit the connection must be established as evident from the drawing.

### 20mA-current loop interface (to the peripheral units)

The 20mA-interface usually functions without control and message lines. Via the module PCA2.F20, however, up to 4 peripherals are connected to DATA LINES of CPU PCA2.M32. In order to control the data transfer, an output (for RTS) and an input (for CTS) have been provided for each peripheral unit connected.

Signal level of the data lines	"L": 20mA "H": 0mA
Signal level of the control lines RTS (output of the type PCA1.B90)	5...36VDC; $I_{max}$ 0.5A
Signal level of the message line CTS (input of the type PCA1.B90)	"L": 0... 4VDC "H": 19...32VDC

### Connector pin assignment for the 20mA-current loop

Pin no.	Abbreviation	Signal name	Direction of the signal			
			Periph.	PLC		
12 11 9 10	TS TA TC TG	Transmitter Source Transmitter Anode Transmitter Cathode Transmitter Ground	} ←			
24 25 23 22	RS RA RC RG	Receiver Source Receiver Anode Receiver Cathode Receiver Ground		} →		
14 15 16	UV Output (RTS) UG	User Voltage Request to Send User Ground			} ←	
17 18	Input (CTS) UG	Clear to Send User Ground				} →

Connecting cable for the 20mA-current loop (to peripheral units)

With the 20mA-current loop good protection against interference for line lengths of up to 1000m is ensured. In an environment with weak interference fields an unscreened cable can be used.

The connecting cable can be designed in such a way that the peripheral interfaces of the PCA2.F20 can be active or passive. In order not to stress the power supply needlessly, we recommend to switch the interface of the peripheral unit to be active (see technical data):

PCA2.F20 passive:

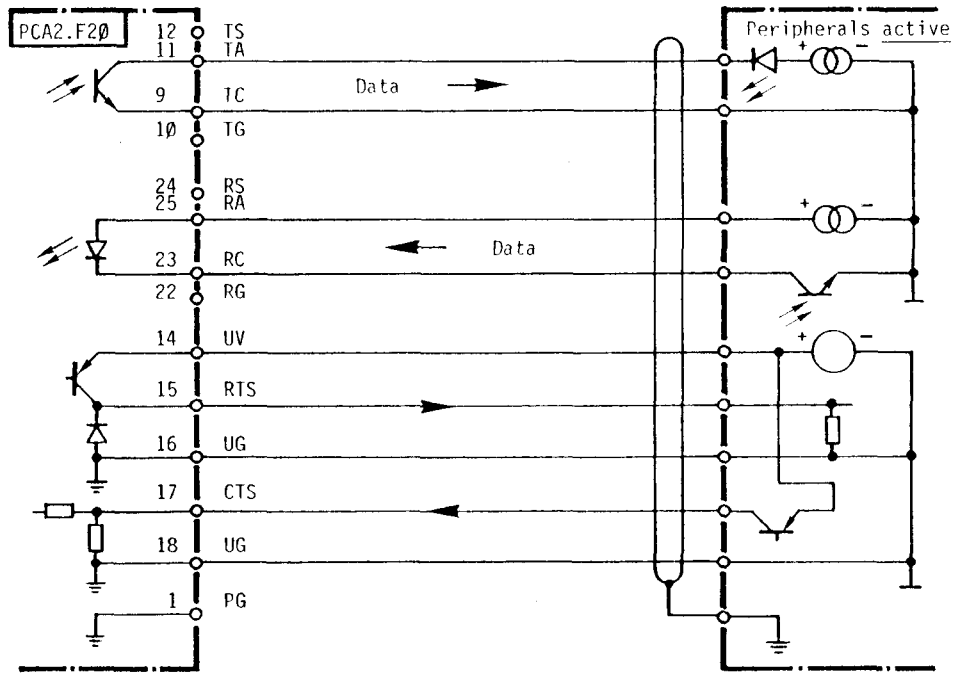

PCA2.F20 active: \*

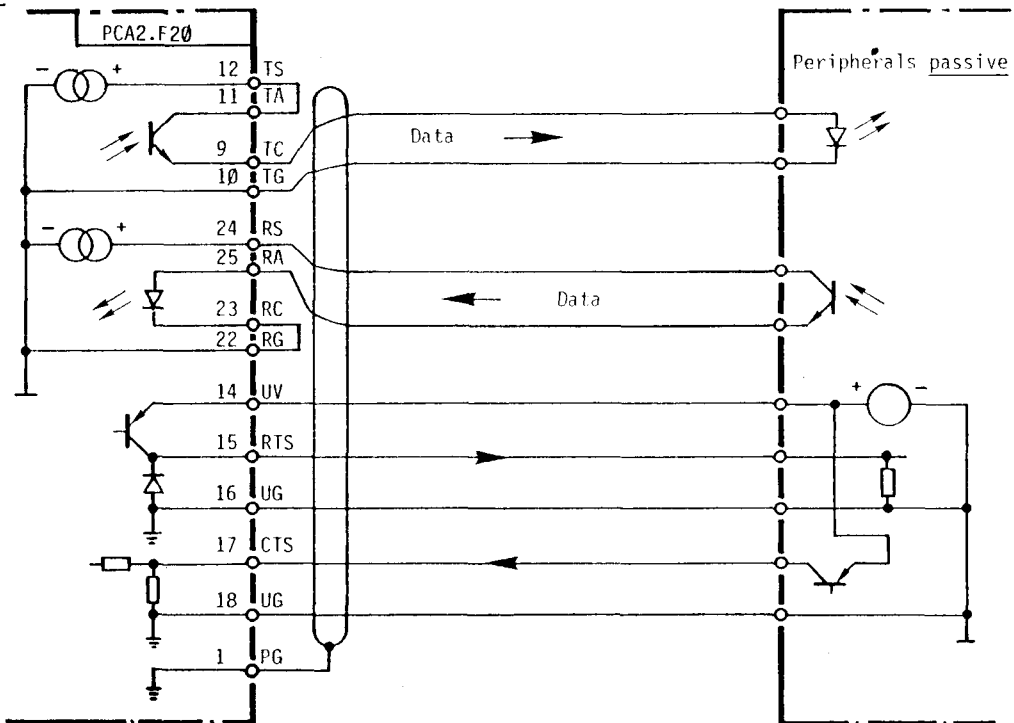

\*) Note the current consumption of the module (see technical data).

### The front connectors of the PCA2.F20

Both the DATA LINES connector and the 4 peripheral connectors are 25-pin miniature connectors, male. They are all fitted with a sliding lock in order to fix the cable connector.

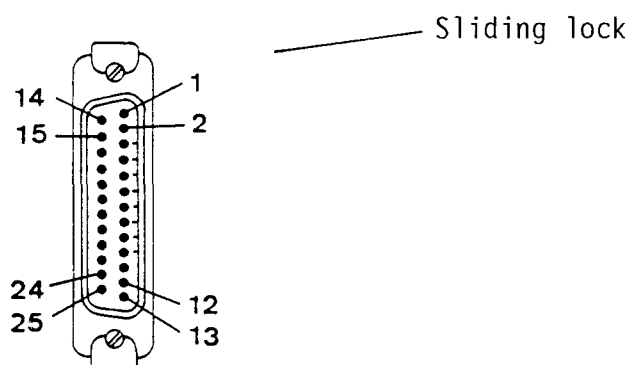

The signal allocation of the connector pins 1...25 for the DATA LINES connector and the peripheral connectors 0...3 are given in the corresponding chapter.



### B 1.6 Selection of power supply modules depending on the power requirement of the PCA2 I/O modules

The power supply modules of the PCA2 meet the internal power requirement of all PCA2-modules at the voltage levels 5V and 25V. When using many modules M32, W1.. and H10, the load limit of the power supply units may be exceeded. In order to avoid this, the nominal load of the power supply modules is compared to the power consumption of the respectively active modules as follows. Note especially the 5V column:

#### Current load of the PCA2-power supply modules

Type PCA2	V <sub>in</sub>	I for 5V (A)		I for 25V (A)	
		max.	average	max.	average
N20	DC	4.0	4.0	1.0	1.0
N21	DC	6.0	6.0	1.0	1.0
N30	AC	4.0	4.0	0.4	0.4
N31	AC	8.0	8.0	0.4	0.4

#### Power consumption of the PCA2-modules

Type PCA2	I for 5V (A)		I for 25V (A)	
	max.	average <sup>1)</sup>	max.	average <sup>1)</sup>
M32		1.14	0.04 <sup>2)</sup>	0.01
M21/M22		0.62	0.04 <sup>2)</sup>	0.01
R16		0.04		
R23 (4K)		0.14		
R26/R27/R28/R29	0.05	0.03		
P05/P10		0.20		
E10/E11	0.26	0.15		
E20	0.14	0.09		
E30	0.26	0.15		
E60	0.07	0.04		
A10	0.34	0.29	0.14	0.11
A21	0.16	0.09	0	0
A31	0.21	0.15	0.01	0.01
A40	0.34	0.29	0.02	0.02
W1..	0.85	0.67	0.08	0.04
W2..	0.08	0.04	0.02	0.01
H10		0.56		0.04
H11		0.03		
H12		0.01		0.05
F20	0.48	0.3		0.05 <sup>3)</sup>

1) 50% of all I/O are active

2) With DATA LINES being active

3) Plus 50mA per active current loop

Example

Type PCA2	I for 5V (A)		I for 25V (A)	
	max.	average	max.	average
M32	1.14	1.14	0.04	0.01
2xR26	0.10	0.06		
P05	0.20	0.20		
4xE10	1.04	0.60		
3xA40	1.02	0.87	0.06	0.06
Total	3.50	2.87	0.10	0.07
Power supply				
N20	4.0	4.0	1.0	1.0
N30	4.0	4.0	0.4	0.4

It is assumed that never all inputs/outputs are active at the same time. In the above example power supply module PCA2.N20 as well as N30 is sufficient. If the number of I/O-modules is increased at a later stage, however, take care that the power rating reserve is not exceeded.



**Chapter B 2**

**Programming units, additional units  
and accessories**

## B 2 Programming units, additional units and accessories

### B 2.1 Additional units used for programming (simulation, starting-up, documentation)

P05	Hand-held programming unit	PCA2.P05
S10	Input simulation unit	PCA2.S10
K70	Cable	PCA2.K70
P18	Programming unit	PCA2.P18
PCASS	SAIA°PCA ASSEMBLER	PCASS
P16	EPR0M-copying unit	PCA2.P16

#### B 2.1.6 Memory modules

R95	Memory module 4K, non-volatile	PCA1.R95
R96	Memory module 4K, non-volatile	PCA1.R96

#### B 2.2 Display modules

D12	Display module (remote display) 4-digit	PCA2.D12
D13	Display interface for D12	PCA2.D13
D14	Display module (remote display) 2x6 digit	PCA2.D14

#### B 2.3 External interface module, type KOM

KOM 111B	Dual-input interface, 220VAC, type D4, output 24VDC/40mA per input
KOM 111B	Dual-input interface, 110VAC, type C8, output 24VDC/40mA per input
KOM 121B	Dual-relay output interface, type M4
	Switching power AC1 : 6A, 250VAC (per output)
	AC11: 1A, 250VAC (per output)

#### B 2.4 Dimensions of the accessories

#### B 2.5/B 2.6 Dimensions and installation of display module PCA2.D12/14

## B 2.1 Programming units

### B 2.1.1 Hand-held programming unit PCA2.P05

This compact programming unit was developed in particular for the series PCA0, but it can also be used for the series PCA1 and PCA2.

Programming is performed in the "PROG" - operating mode by means of a 10-part keyboard in simple numerical code. All elements ( inputs, outputs, flags, timers, counters ) can be queried or set in the operating mode "MAN".

All timer and counter values can be indicated in the RUN-mode. In the operating mode "STEP" a jump can be effected to any program line (= step address) of the user memory. "BREAK" permits the program processing up to a set break-point and continuation in step-by-step operation. For details refer to chapter C "Operating modes".

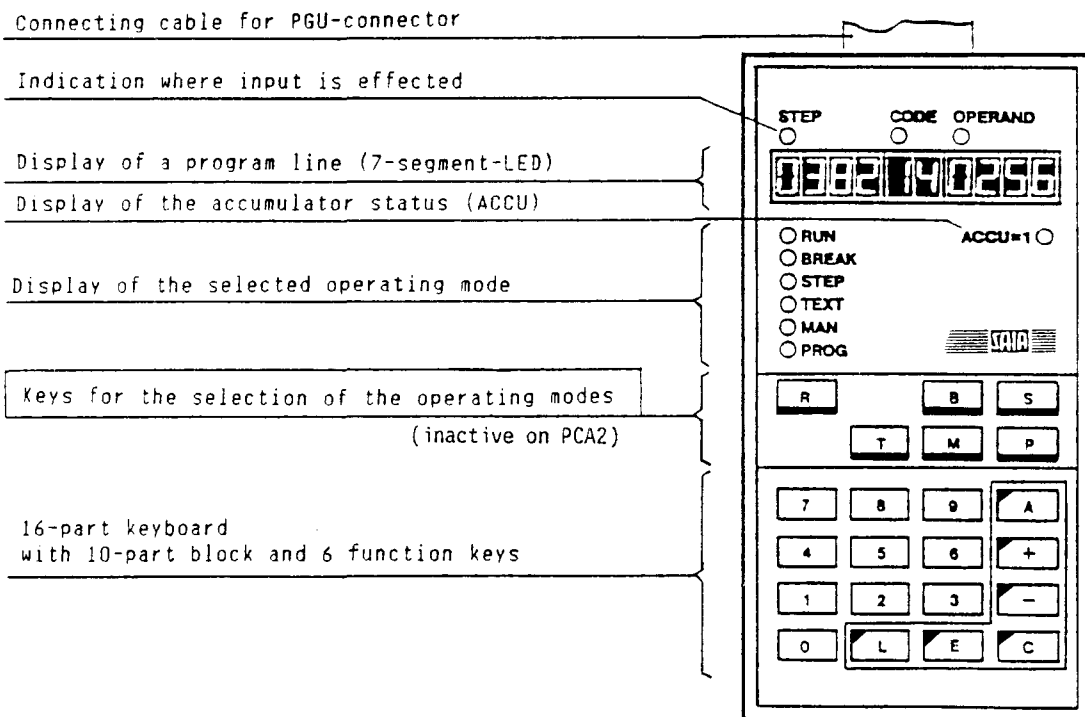

B 2.1.2 Input simulation unit type PCA2.S1Ø

Its purpose is to simulate input signals via toggle switches so that a program can be tested "at the desk". This considerably facilitates the commissioning of the actual control system.

A transformer with rectifier is supplied from a mains cable. From the rectifier is a branch to 32 numbered toggle switches, the signals of which are fed to the PLC inputs via a system cable and plug.

Ordering designation for connection to 22ØVAC: PCA2.S1Ø D4

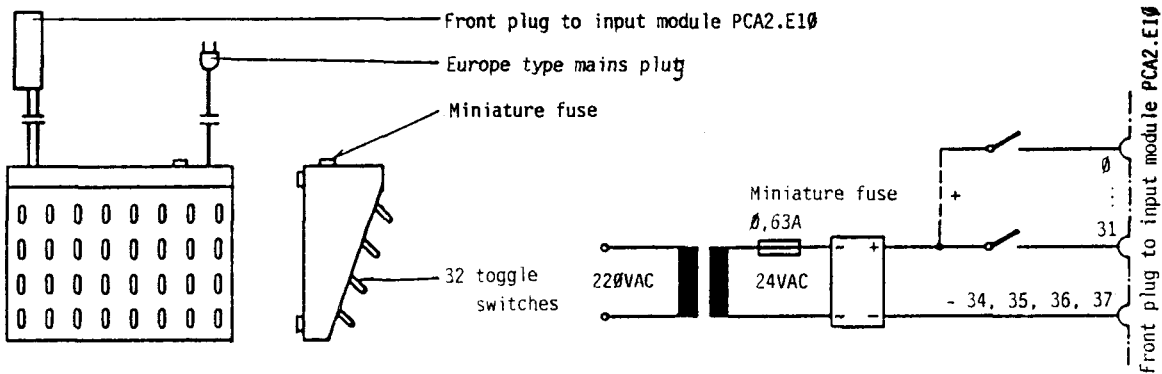

Intermediate cable type PCA2.K7Ø for connection to input module PCA2.E2Ø

As the E2Ø input cards have no joint negative pole and are provided with only 16 inputs, this intermediate cable must be used.

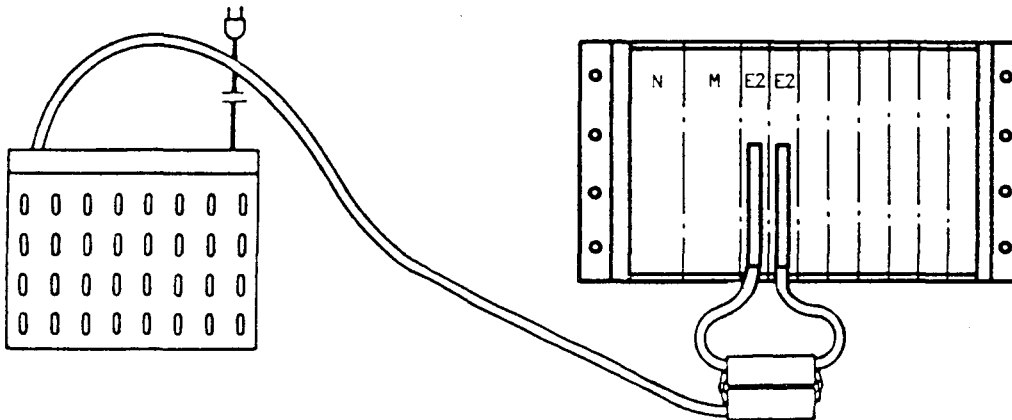

### B 2.1.3 Programming unit PCA2.P18

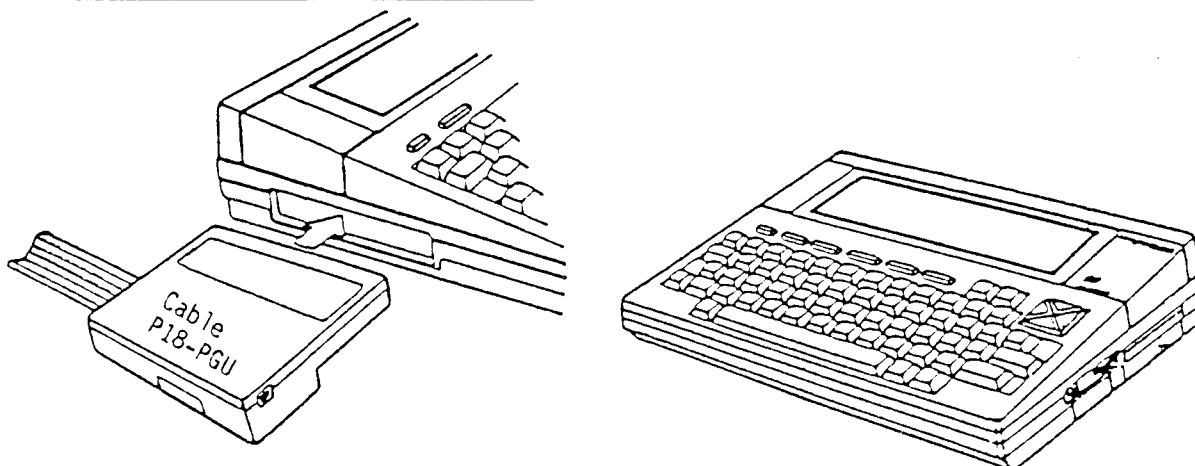

#### Brief description

The programming unit PCA2.P18 is a compact and versatile means which can be used for programming all SAIA°PLC as well as for servicing.

The P18 uses the commercially available hand-held computer, type NEC 8201A, as hardware. Compactness combined with a high degree of intelligence, an efficient firmware and a variety of peripherals form an ideal portable programming unit, be it on your desk or out in the field.

With the SAIA°PLC connected (via PGU-connector), the P18 makes programming very easy. Moreover, SAIA°PLC texts can be edited or all PLC-registers can be accessed on-line for servicing purposes via the 20mA-data line of the PCA 222 and PCA 232.

In short, the following functions are possible:

- Programming in numerical or mnemonic code
- Display of program sections and texts
- Search functions
- Storage and loading of user programs and texts
- Printing of programs (on an external printer)
- Editing and output of SAIA°PLC texts
- Access to data and registers of SAIA°PLC while user program is running.

Thanks to the permanently stored BASIC-interpretor and the text processing program, the P18 can also be used as a portable personal computer. Numerous additional interfaces and the corresponding software support communication with peripheral units such as printer, modem, tape unit, disk drive unit and bar code reader.

A detailed description is supplied with each unit.



#### B 2.1.4 SAIA°PCA-ASSEMBLER

##### The software package SAIA°PCA-ASSEMBLER for comfortable programming, documentation and starting-up

The PCA-ASSEMBLER makes programming of the PCA-family of controllers very easy. The user is efficiently supported in his work by practical menus and the appropriate "HELP" pages which means that he virtually does not require a manual or a knowledge of MS-DOS.

The user program is written in the so-called "Editor" using a conventional text processing program (e.g. Personal Editor or Wordstar). It is possible to use practice-oriented designations for the operands to mark jumps in the form of symbols and labels which are then converted to a PCA-program by the actual "Assembler" and "Linker". Macros with parameters can be implemented for frequently used routines and comments can be used for clearly documenting the new program.

Further possibilities of the new PCA-ASSEMBLER include the modular and global documentation, presentation as flow-charts, an efficient cross-reference list and it is also possible to load the program directly into the RAM-memory of the PCA.

Its advantages become obvious particularly when the controller is started up. In RUN-mode the "Online Debugger" allows the actual states of elements such as inputs, outputs, flags, timers, counters, registers and the date-time to be displayed and also modified. The programs "P10" and "CI" permit direct access to the RAM user memory of all PCAs. By selecting the submenu "Program eproms", tested user programs can be directly loaded into the EPROM programming units PCA2.P16 or ERTEC PGS49.

The software package SAIA°PCA-ASSEMBLER can be run on all IBM-PC/XT/AT or PS/2 or compatible units which fulfil the following conditions:

- 512 KByte main memory
- 2 floppy disk drives of 360K or even better 1 floppy disk drive and a hard disk
- 1 or even better 2 bidirectional, parallel interfaces for controlling a printer and for connection to the PGU-connector of the PCA
- Monochrome or colour VDU (with MCGA, CGA, EGA, VGA or Hercules cards)
- Keyboard as desired
- Operating system MS-DOS 3.0 or a higher version
- Cable PCA2.K43 for connection to the PGU-connector of the PCA
- Text processing program as desired (Personal Editor and Wordstar are recommended)

A detailed description is available for every software package.

The SAIA<sup>®</sup>PCA-ASSEMBLER software package is available in three complementary packages:

- PCASS1 ONLINE                      The basic package mainly contains the tools needed for commissioning as well as for writing or modifying program directly in the PCA.
  
- PCASS2 PROGRAMMING              The main package includes the entire PCASS1 package as well as the tools "Assembler", "Linker", "Disassembler", "Textassembler", etc. They allow preparing and documenting extensive programs in various ways by using symbols, labels and macros.
  
- PCASS3 TRANSFER                  It includes aids for optimizing communications programs and loading EPROMs.

All software packages are available in German, French or English and, if desired, on a 5 1/4" or 3 1/2" disk.

ScreenMain menu of PCA-ASSEMBLER

SAIA PCA ASSEMBLER V1.1		MAIN MENU
***** SAIA AG Marktbereich CH 3280 Murten *****		
Directory: C:\PCASS		16.12.88 13.30
Edit	Text assembler	Compare programs
Assemble	Disassembler	Xref listing
Link	flow chart	File handling
Up/download	Runtime analysis	Ms-dos command
<b>Online debug</b>	Hex converter	Setup
comms Interface	Program eproms	Quit
<b>&lt;ARROW&gt;, &lt;SPACE&gt; or &lt;Tab&gt; selects operation, &lt;CR&gt; or &lt;Command letter&gt; executes</b>		

ONLINE DEBUG menu of PCA-ASSEMBLER

SAIA PCA ONLINE DEBUG V3.4	
<b>Display</b> C260 2090 e12 0011 0010 B200 EE EF FF 3B 67  Σ0 1101 0000 0100 0011 T256 2163	<b>Clock</b> wy du yy mo dm hh mm ss 48 03 88 12 15 17 05 58
<b>Write</b>  	<b>Program</b> A 1 03 2 A 2 03 7 A 3 10 12 A 4 10 21 A 5 10 13 A 6 10 24 A 7 14 256 A 8 00 500 A 9 01 256 A 10 10 25 A 11 20 0
<b>Display Write Program clock Save Load comms-interface Reset Quit</b>	

### B 2.1.5 Type PCA2.P16 EPROM-copying unit

Owing to two high-quality sockets (Textool) the unit can be used for copying and comparing EPROMs and buffered RAMs independently of other units. The serial interface RS 232c permits connection of any commercial personal computer. A program supporting operation of the P16 from the IBM-PC is part of the PCA-assembler (package no. 3).

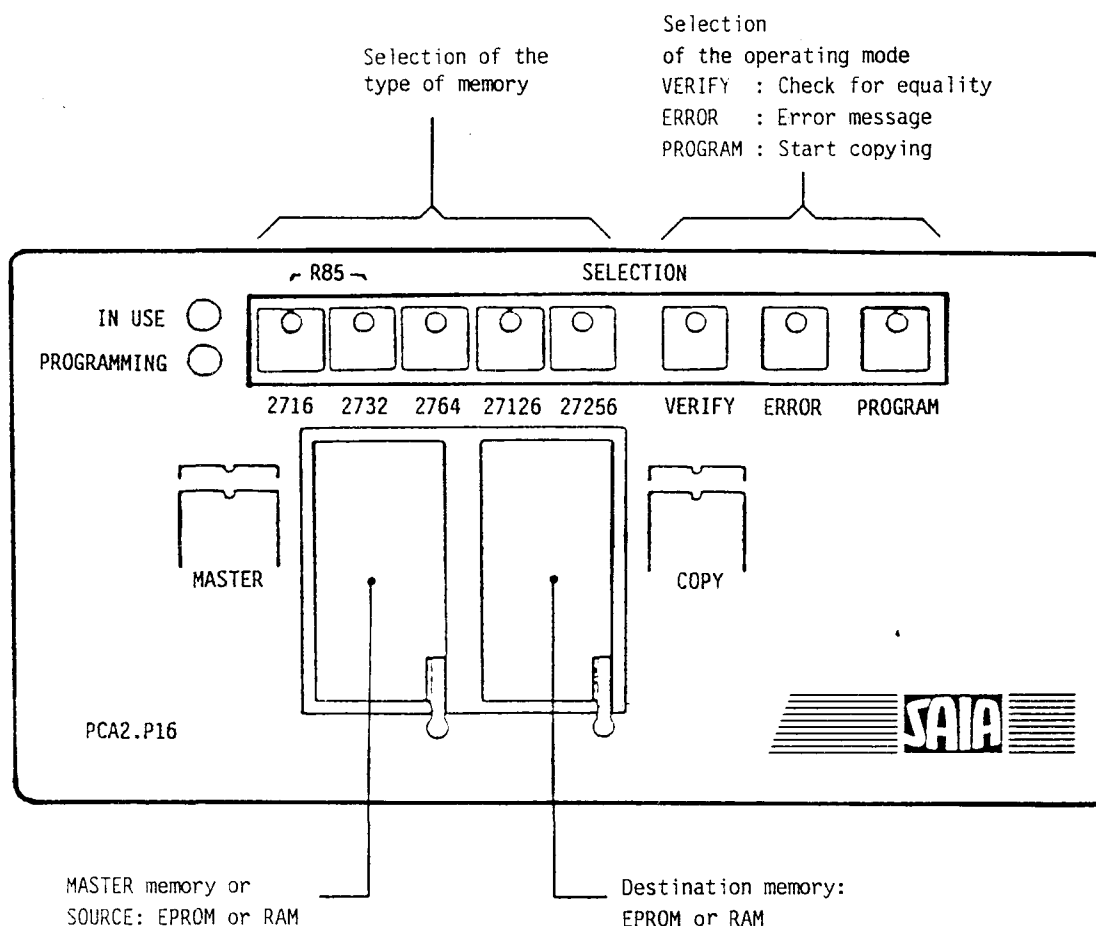

The P16 meets especially the requirements of the SAIA<sup>®</sup>PLC. In addition to the usual EPROM types 2716 to 27256, the buffered RAMs PCA1.R95 and PCA1.R96 can be written to and read.

A detailed manual is delivered with each unit.

### Technical data

Supply voltage	220 VAC 50 Hz $\pm$ 10%
Power requirement	20 VA
Microprocessor	MC 6809
Serial interface	RS 232c (9600, 2400, 1200 and 300 bauds)
Dimensions	222 x 47 x 172 mm (W x H x D)
Weight	1.7 kg

The following memory modules can be programmed with the P16:

Type	Programming voltage
2716	25V
2732	25V 1) 3)
2732A	21V 1)
2764	21V
27128	21V
27256	21V 2)
2816	3)
PCA1.R95 (buffered RAM)	
PCA1.R96 (buffered RAM)	

- 
- 1) For the type 2732A the P16 has been set to a programming voltage of 21V (factory setting).  
For the type 2732 which has a programming voltage of 25V, a jumper needs to be re-soldered on the pc-board EP 80 067.
- 2) For the type 27256, which has a programming voltage of 12.5V, the resistor R3 (3k6) needs to be changed to 2k on the pc-board EP 80 066.
- 3) Do not use with SAIA<sup>o</sup>PLC.

### Copying

During copying, data is read from a master-IC and written to a copying-IC. When working without the Personal Computer, i.e. without using the serial interface, copying can usually be performed only using the same types of EPROM. However, mixed operation is possible using the EPROM 2764 and buffered RAMs PCA2.R95 or PCA2.R96. Only the entire memory contents can be copied from the MASTER socket to the COPY socket.

- Select the copying EPROM with the appropriate key. The corresponding LED lights up. For the EPROM-emulators R95 and R96 the keys 2716 and 2732 must be pressed simultaneously.
- Insert the master-IC and the copy-IC in the frames. Take care that the notch or pin 1 respectively is at the top on the left.  
The ICs are retained in the frames by pressing down the levers. In the case of the 24-pole ICs it must be noted that the upper contact openings must not be covered.

3. Press key 'PROGRAM'. The LED 'IN USE' lights up for a short time. During this time a check is performed to determine whether the memory module to be programmed has been erased. Afterwards the LED 'PROGRAMMING' also lights up until programming is finished. Any errors which occur during programming, are displayed by the flashing LED 'ERROR'. Moreover, an LED lights up in the keys indicating the type of error.

#### Error messages

Key 2716 : EPROM cannot be programmed  
Key 2732 : EPROM has not been erased  
Key 2764 : EPROMs are different  
Key 27128: EPROMs are different and copy-IC empty  
Key 27256: 2816 cannot be erased

The error display is cleared with the key 'ERROR'.

#### Comparing

The procedure is similar to copying. However, the LED 'PROGRAMMING' does not light up. Proceed as follows:

1. Select copying-EPROM with the appropriate key.
2. Press key 'VERIFY'.

If no error message appears, the contents of the two memory modules are the same. The flashing LED 'ERROR' indicates an error (see list of errors).

#### Erasing the 2816 (EPROM)

In order to erase the 2816, press the key 'ERROR' and '2716' simultaneously.

Important: The memory module 2816 cannot be used together with SAIA°PLC.

When the PCA2.K46 cable is used, the transfer of data is supported under menu-guidance by the SAIA°PCA-ASSEMBLER with the "Program eproms" program (in package no. 3).

### B 2.1.6 Type PCA1.R95/R96 Buffered RAM chip

RAM-memories are read-/write-memories, which means that the information can be modified at any time with the aid of a programming unit (as data memory in the PCA2 also via the user program).

The buffered RAM chip is the ideal memory chip serving as a program and text memory from the programming stage to the start-up. Owing to the incorporated buffer battery and the protective electronic system, this memory chip can be detached from the PLC and transported without modifying its contents.

The slightly conductive plastic socket protects the pins against static charges, thus avoiding memory content changes. The internal battery is thereby not discharged.

Memory type	PCA1.R95	PCA1.R96
Storage capacity		
- Program lines	4K	4K
- Texts, data	8K	8K
Number of pins	28	28
Buffer battery life	approx. 8 years	approx. 6 years

Application in PCA14/15, PCAØ and PCA2.

#### Presentation

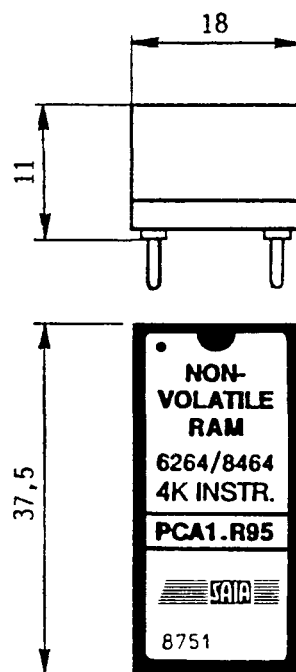

## B 2.2 Display modules

### B 2.2.1 Type PCA2.D12 Display module

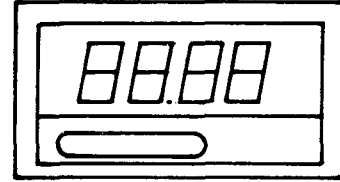

#### General

The PCA2.D12 module is a remote display which can be controlled via SAIA<sup>®</sup>PLC outputs. It has a 4-digit display and is able to indicate a decimal point. The display can be built in anywhere at a greater distance to the PLC e.g. in the door of a control cabinet or an operating panel. Due to data transmission being effected via outputs, several displays can be controlled by one PLC. In conjunction with the display interface PCA1/2.D13 the D12 can be connected even at a greater distance to the PGU-connector where the comfortable instructions DTC and DOP are available.

#### Structure, function

The module is in the same housing as the electronic totalizing counter of the CKG type. It consists of the following main components:

- power supply 24VDC
- 3 inputs for 24VDC
- decoder/driver
- 4-digit, 7-segment display with decimal point

The 3 outputs of the PLC resp. the 3 inputs of the display are designated "Enable", "Data" and "Clock". The Enable signal activates the display, i.e. Enable = "L" --> display is able to receive data, Enable = "H" --> display is inactive (it is not able to receive new data). Via the "DATA" line data in BCD-format is transmitted sequentially, i.e. bit by bit from the SAIA<sup>®</sup>PLC to the display. The display accepts each bit with the falling edge of the "Clock" signal.

For a complete indication (4 digits with or without decimal point) always 20 clock signals must be generated and 20 data bits must be transmitted (4 BCD-values + 4 bits for the decimal point).

The following sequences of the 20 data bits must be adhered to:

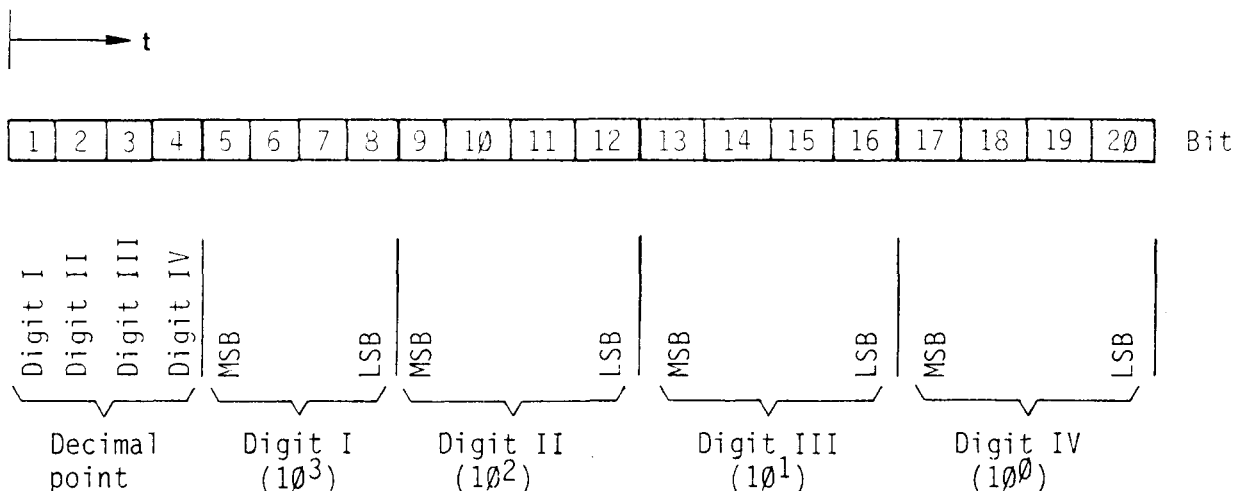



The following 16 characters can be presented per segment:

Character	Code	Character	Code
∅	0000	□	1010
1	0001	┌	1011
2	0010	├	1100
3	0011	└	1101
4	0100	-	1110
5	0101	"blank"	1111
6	0110		
7	0111		
8	1000		
9	1001		

The connection between "Enable", "Clock" and "Data" is illustrated in the time-dependency diagram:

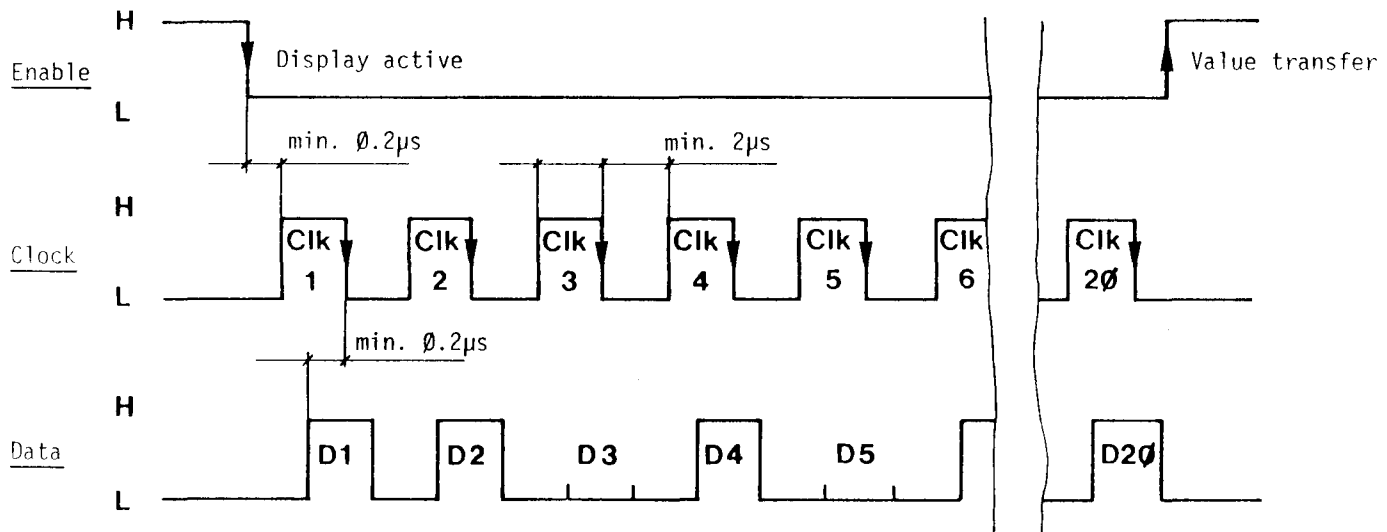

For the generation of the "Clock" as well as for the transmission of data the user must write a short program (examples will follow at the end). In this program, all functions shown in the above diagram, must be realized.

The minimum clock pulses and waiting times are short, so that the instruction set of the SAIA<sup>®</sup>PLC can easily be applied directly without waiting for certain periods to elapse.

### Presentation and terminal arrangement

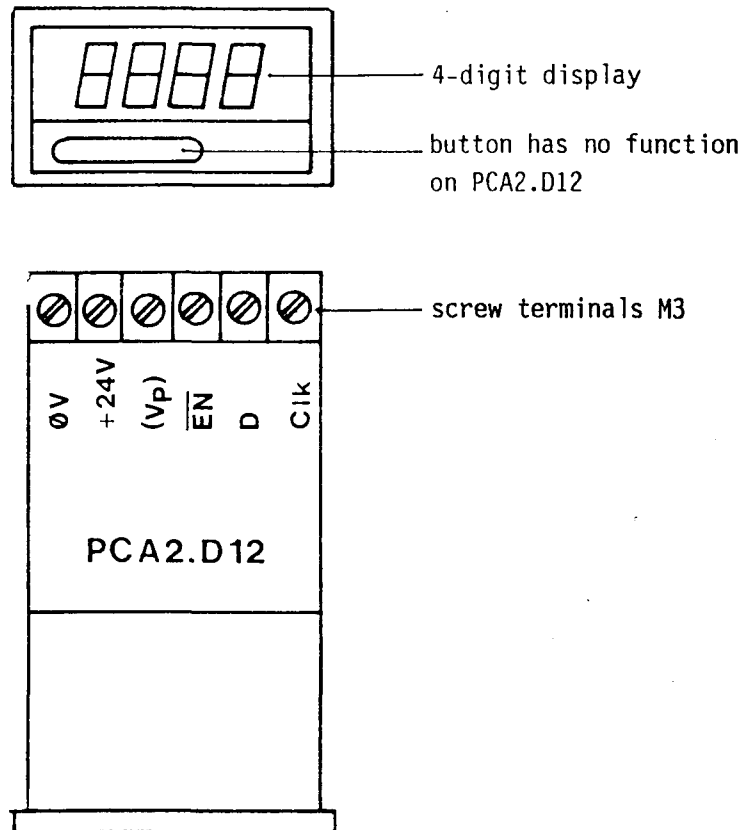

### Technical data:

- |   |  |
|---|--|
| - Supply voltage                              | 24VDC $\pm$ 20%, two-way rectification is sufficient |
| - Input voltage for EN, D, CLK                | 24VDC, smoothed                                      |
| - Input current for 24VDC                     | 10mA   |
| - Definition of the input voltages            | "H": 19V...32V<br>"L": 0V... 4V                      |
| - Input delay                                 | < 1ms  |
| - Usable SAIA <sup>o</sup> PLC output modules | PCA1.A10, B10, B80, B90<br>PCA2.A40                  |
| - Control                                     | serially via 3 PLC-outputs or via interface D13      |
| - Connection V <sub>P</sub>                   | Output, used to supply D13 with voltage              |
| - Dimension drawing see chapter B2.5          |  |

Input circuit and block circuit diagram

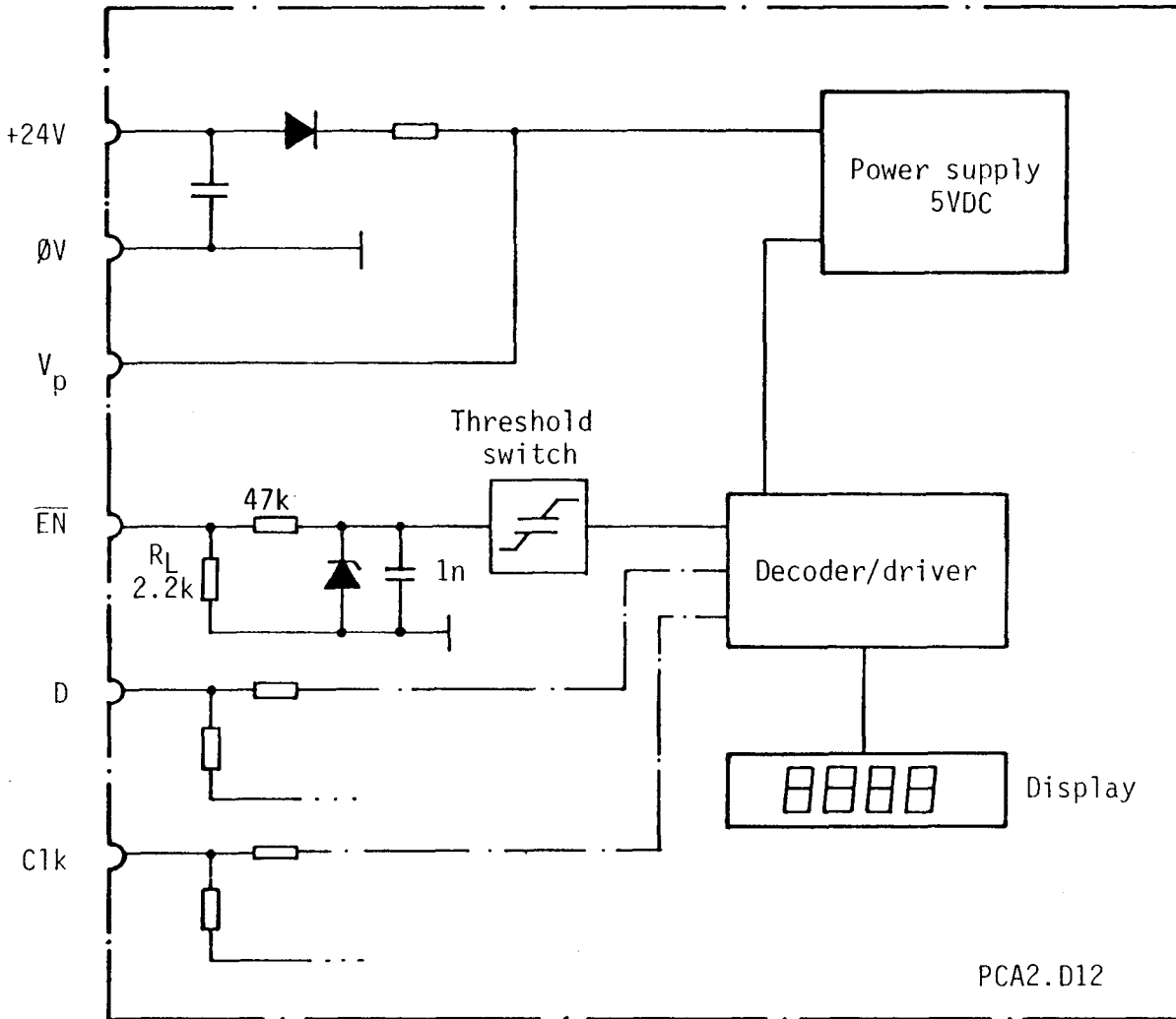

Note:

$V_p$  supplies display interface D13.

Connection of several displays to a PLC

Since the PCA2.D12 module is able to transmit an "Enable" signal, i.e. it can be switched to be active or inactive, the same "Clock" and "Data" signals can be used for several displays. These are transmitted to each display simultaneously. The "Enable" signal decides which display is controlled. This means that for each display one "Enable" signal is necessary (1 output per display). This also means, however, that for as many displays as desired only one data and one clock output must be provided.

Connection: (e.g. PCA2.A40 - PCA2.D12)

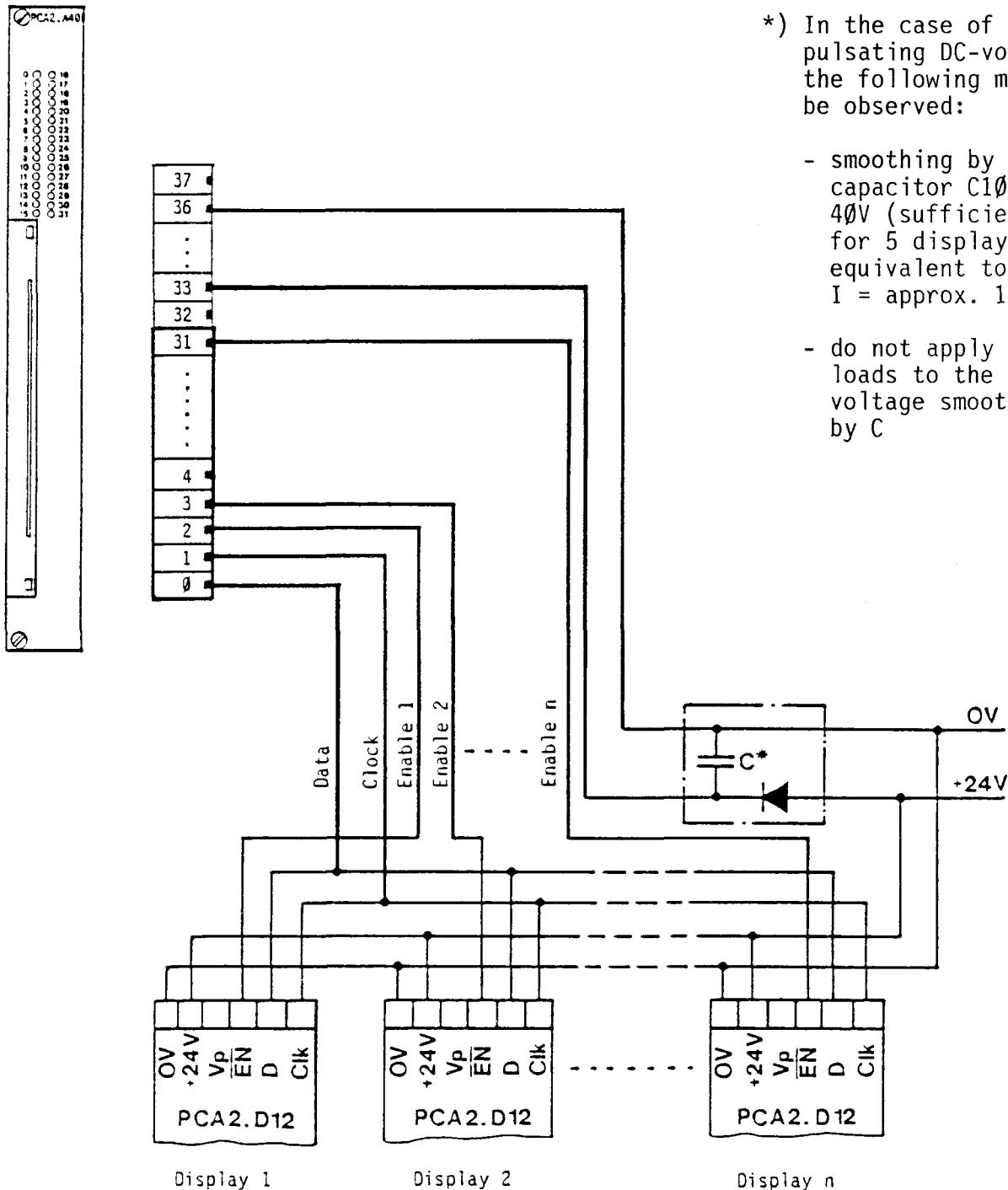

\*) In the case of a pulsating DC-voltage the following must be observed:

- smoothing by capacitor C100  $\mu$ F, 40V (sufficient for 5 displays is equivalent to I = approx. 100mA)
- do not apply other loads to the voltage smoothed by C

Examples

Example 1

Six PCA2.D12 displays are to be connected to one SAIA<sup>®</sup>PLC. How many outputs are required?

Solution 1

Per display module one "Enable" signal	6 outputs
1 "Data" signal (simultaneously to all display modules)	1 output
1 "Clock" signal (simultaneously to all display modules)	<u>1 output</u>
<u>Total</u>	8 outputs =====

Example 2

Every half second a counter is to be incremented up to the value 9999 and then reset to zero. Its content is to be indicated on the PCA2.D12 display module with a decimal point in the 2nd place.

The following outputs must be assigned for "Enable", "Data" and "Clock":

EN : 02  
D : 03  
CLK: 04

Used counters: C280  
C281

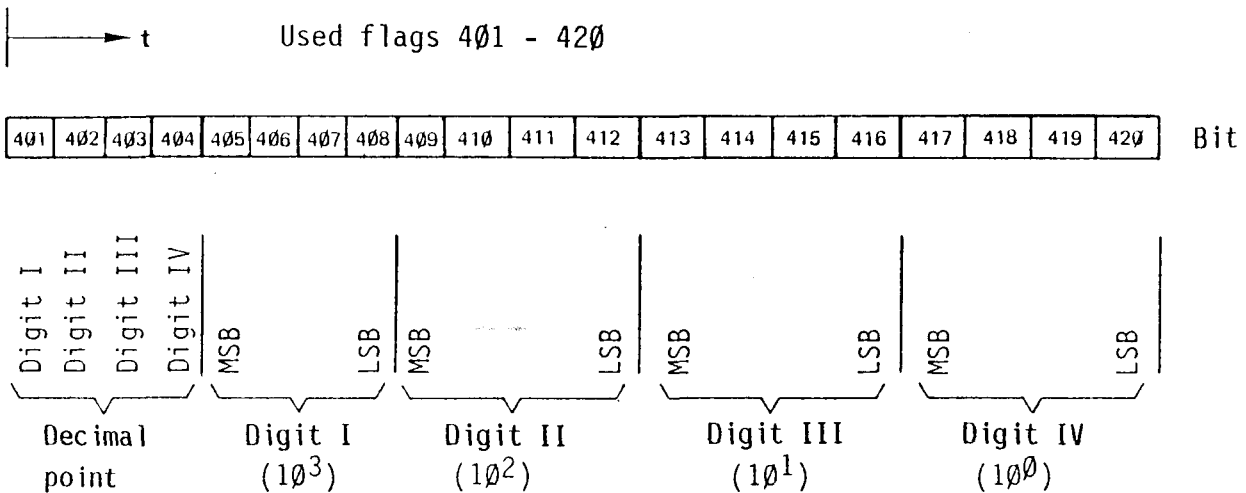

Solution 2

```

10 (SEA 0) (When not need as subroutine)
11 SCR 280
12 SCR 0 0 ; Initial value 0
13 SCR 281
14 04 1807 ; Maximum value 9999
15 SCR 280
16 20 420 ; Counter contents on flags (20 bits)
17 SEO 402 ; Decimal point in 2nd place
18
19
20
21 SEA 0
22 REO 2 ; Enable = "L"
23 SEI 0
24 SEO 4 ; Clock
25 STH 1401 ; Flag 401...420
26 OUT 3 ; Data
27 SEA 0
28 REO 4 ; Clock
29 INI 19
30 JIO 23
31 SEO 2 ; Enable = "H"
32
33 DTC 280 ; Operand display
34 DEC 281 ; -1
35 STL 281 ; 0 ?
36 JIO 10
37
38
39 INC 280 ; (0,1,2,3...9999,0,1...)
40 STR 256
41 00 5
42 WIH 256 ; Wait 0.5s
43 JMP 15
    
```

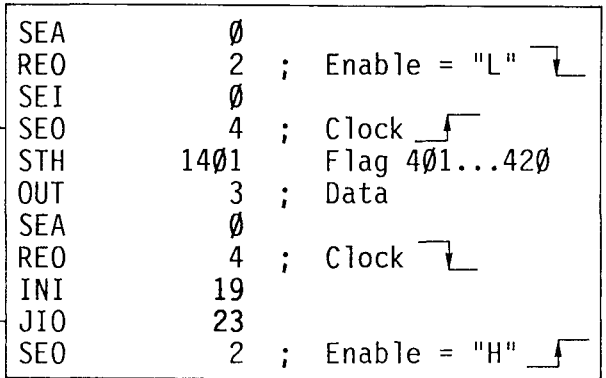

Standard routine for controlling the display

t → Used flags 401 - 420

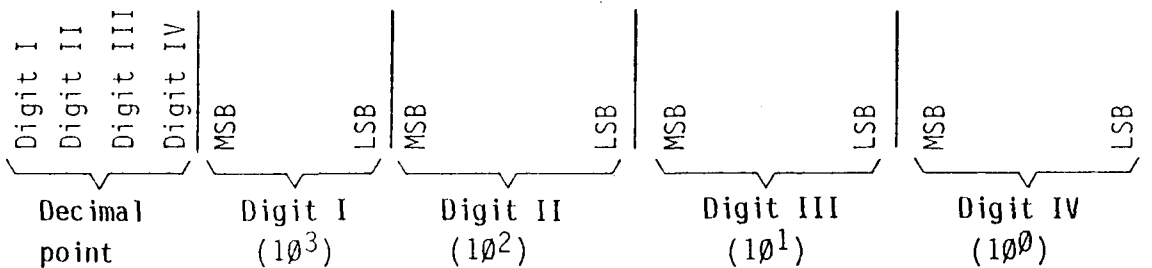
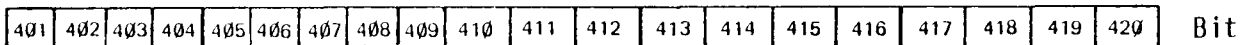

### B 2.2.2 Type PCA2.D13 Display interface

#### Description

The display interface D13 combines the advantages of the display module PCA1.D11 for PCA1 (simple software handling via the instruction DTC and DOP for 4-digit decimal displays) and those of the display PCA2.D12, which need not be located anywhere near the SAIA°PLC.

The D13 is inserted in the PGU-connector of the SAIA°PLC and connected to the display PCA2.D12 by means of pluggable screw terminals.

#### Technical data

- Supply voltage  $V_p$ : 24VDC,  $\pm 20\%$ , full-wave rectified is sufficient (supplied by the display module PCA2.D12)
- 3 opto-isolated outputs for EN, D, CLK
- Connection of 2 displays PCA2.D12 is possible (same display)
- Control by means of the instructions DOP and DTC (see manual Software 1H)
- Concerning the cable layout and type of cable between D12 and D13 no special measures are required. The same general criteria as for the cabling of input and output modules apply (see chapter A 8).

#### Presentation

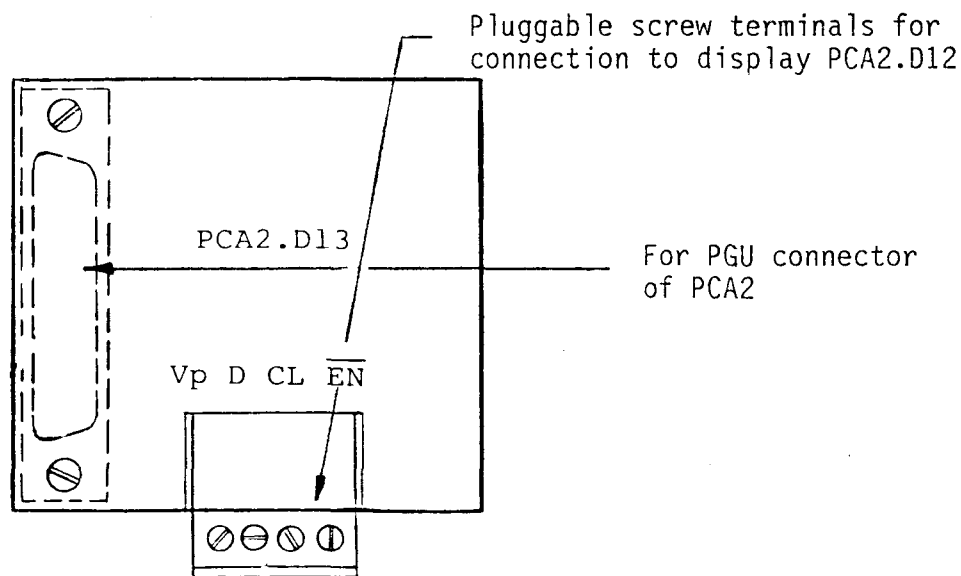

### Connection diagram

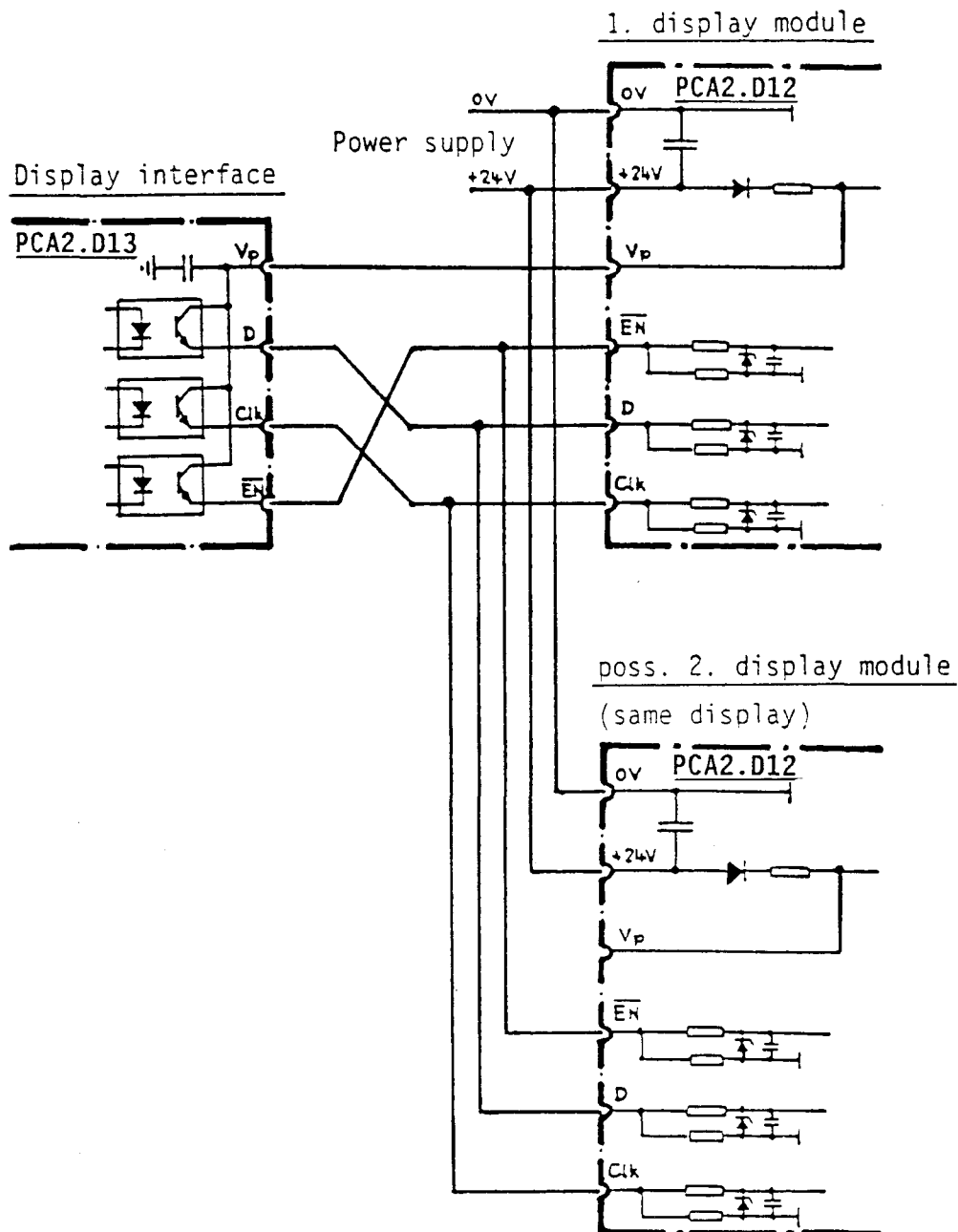

#### Note:

- Both displays indicate the same data.
- Module D13 is supplied by module D12 backwards via the terminals Vp. This and the use of optocouplers ensure maximum interference protection of the PCA2.



Connection to display module PCA2.D12

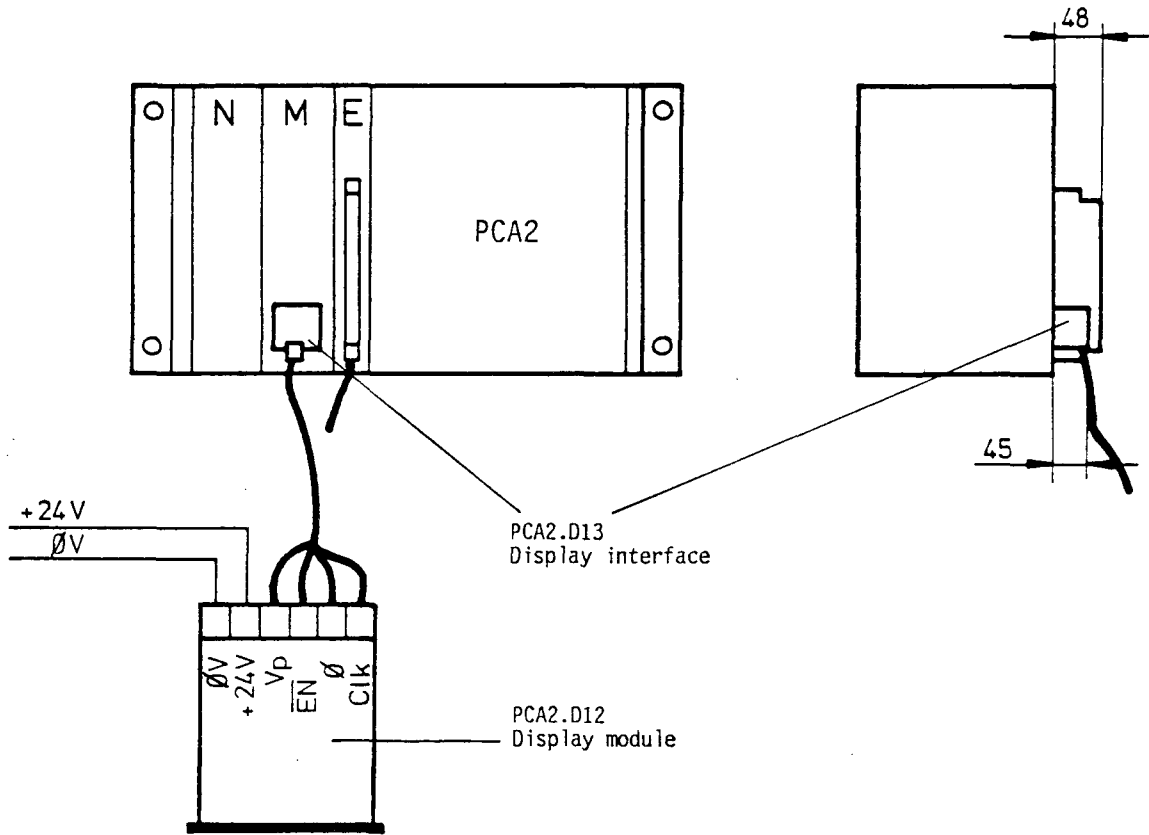

### B 2.2.3 Type PCA2.D14 Display module

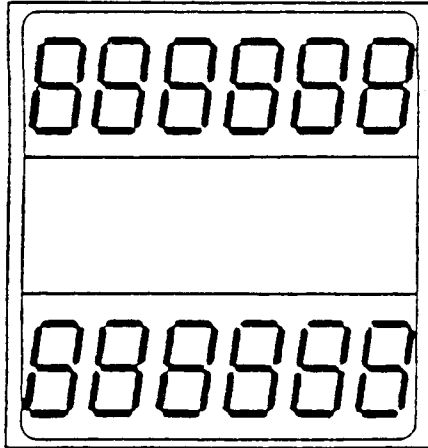

#### General

The PCA2.D14 module is a remote display module which is controlled via 3 outputs of the SAIA°PLC. The module has two 6-digit displays. Several PCA2.D14 can be connected in series in case of more than two displays.

#### Application, control

The module was developed in connection with the fast counter module PCA1.H10. In this application controlling is performed by the counter module alone. The user must only program the appropriate mode in the user program.

When the PCA2.D14 is used without the H10 module, the information to be displayed is most easily transmitted serially with a standard program routine from a flag field via 3 SAIA°PLC outputs.

#### Technical data

Display	2 times 6 digits, 7-segment LED
Digit height	10mm
Supply voltage	24VDC $\pm$ 20%, full-wave rectified is sufficient
Input voltage for EN, D, CLK	24VDC smoothed
Input current at 24VDC	10mA
Definition of the input level	"H" = +19...+32V "L" = 0...+ 4V
Input delay	< 1ms
Usable SAIA°PLC output modules	PCA1.A10, B10, B80, B90 PCA2.A40
Control	serially via 3 SAIA°PLC-outputs irrespective of the number of D14

Structure, function

The module is located in the same housing as the electronic totalizing counter CKG/AC.

Terminals: Screw terminals combined with connection strips (2.8 x 0.8 mm) for flat pluggable bushes or soldering.

PLC-output	Clock	----->	Clk	PCA2.D14
PLC-output	Data-In	----->	D-IN	
PLC-output	Enable	----->	EN	
Carry	Data-Out	----->	D-OUT	
Voltage supply	+24V	----->	+24V	
Voltage supply	0V	----->	0V	

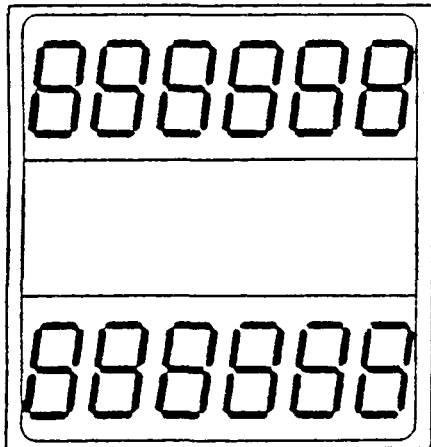

Upper display

Lower display

The data for a display of 2 x 6 digits are most easily presented in a complete flag field, e.g. M500...547 in BCD-notation. If these values are kept in counters, they must be transferred to the flag fields first.

500						523	
M	0 0 0 0	0 0 0 0	0 0 0 0	0 0 0 0	0 0 0 0	0 0 0 0	upper display
	MSB	LSB				MSB	LSB
	100'000	10'000	1'000	100	10	1	
524						547	
M	0 0 0 0	0 0 0 0	0 0 0 0	0 0 0 0	0 0 0 0	0 0 0 0	lower display
	MSB	LSB				MSB	LSB
	100'000	10'000	1'000	100	10	1	

### Software routine

Every time the following routine has been executed the current information in the flag field is indicated on the display until the display is updated by a new piece of information after a further run.

#### Softlevel 1 \*

```

(60  SEA  0)
61  REO  2  ENABLE
62  SEI  0
63  SEO  3  DATA
64  SCR  280 AUX. COUNTER
   00  4
66  SEO  4  CLOCK
67  REO  4  CLOCK
68  DEC  280 AUX. COUNTER
69  STH  280 AUX. COUNTER
70  JIO  66
71  SCR  280 AUX. COUNTER
   00  16
73  STH  1500 FLAGS
74  OUT  3  DATA
75  SEA  0
76  SEO  4  CLOCK
77  REO  4  CLOCK
78  INI  47
79  JIZ  84
80  DEC  280 AUX. COUNTER
81  STH  280 AUX. COUNTER
82  JIO  73
83  JMP  63
84  SEO  2  ENABLE
(85  RET  0)

```

(When not used as subroutine)

#### Used addresses

Enable	O2
Data	O3
Clock	O4
Flag	M500...M547
Aux. counter	C280

for M500...547 with index register

for 1 D14 (upper and lower display) \*\*

(When used as a subroutine)

500						523	
M	0 0 0 0	0 0 0 0	0 0 0 0	0 0 0 0	0 0 0 0	0 0 0 0	upper display
	MSB	LSB				MSB	LSB
	100'000	10'000	1'000	100	10	1	
524						547	
M	0 0 0 0	0 0 0 0	0 0 0 0	0 0 0 0	0 0 0 0	0 0 0 0	lower display
	MSB	LSB				MSB	LSB
	100'000	10'000	1'000	100	10	1	

\*) The display module D14 can thus be controlled from any SAIA<sup>®</sup>PLC (including PCA13 and PCA21)

\*\* ) For connecting several D14 in series see following page.

The following diagram shows several PCA2.D14 connected in series:  
Each D14 displays its own data.

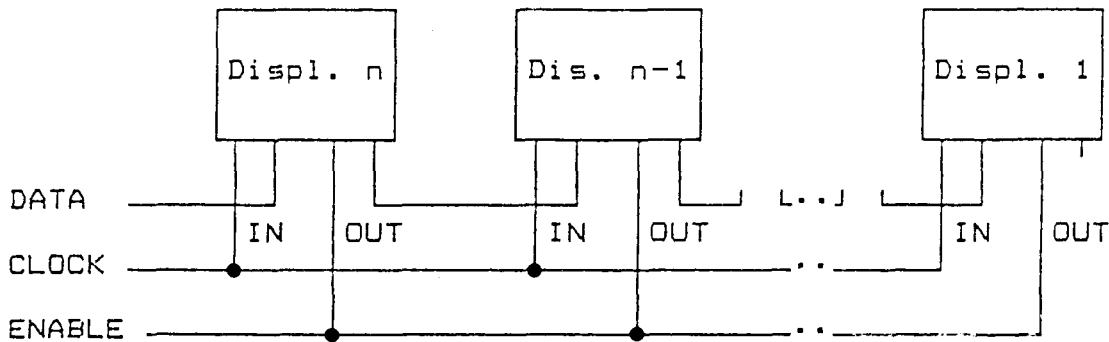

The flag field containing the information to be displayed must be expanded correspondingly:

- for 1 PCA2.D14 = 1 x 48 flags
- for 2 PCA2.D14 = 2 x 48 flags
- for 3 PCA2.D14 = 3 x 48 flags etc.

The routine in the user program remains the same, only the instruction "INI" must be changed accordingly:

- for 1 PCA2.D14 = INI 47
- for 2 PCA2.D14 = INI 95
- for 3 PCA2.D14 = INI 143 etc.

In other words,  $INI (n \times 48) - 1$  with  $n =$  number of PCA2.D14.

The following 16 characters per segment can be presented:

<u>Character</u>	<u>Code</u>	<u>Character</u>	<u>Code</u>
0	0000	␣	1010
1	0001		1011
2	0010		1100
3	0011	└	1101
4	0100	-	1110
5	0101	"blank"	1111
6	0110		
7	0111		
8	1000		
9	1001		

### B 2.3 KOM series external interface module

The purpose of the external interfaces is for adapting the I/O levels of the PLC from 24VDC to the process requirements. They are constructed in two-channel form and mounted in plug-in housings for an 11-way round socket. LEDs indicate the logic status ("H" = ON), facilitating the rapid checking of the signal lines as far as the terminals of the process. To render the wiring easy to view, the cables from the process or to the PLC are arranged on the opposite side of the plug holder.

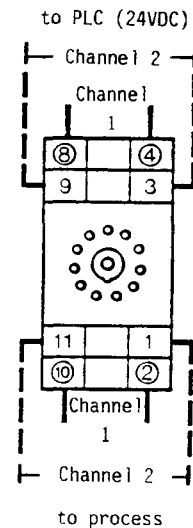

Plug-socket holder  
Order no. 4'408'4817'0

#### B 2.3.1 Type KOM 111B Dual input interface

The purpose of this input interface is for the isolation of the mains control lines from the 24V signal level of the PLC. The isolation is accomplished by means of inductive transmitters; this has the advantage of providing a safeguard against surge voltages.

Front Switching scheme (per channel)

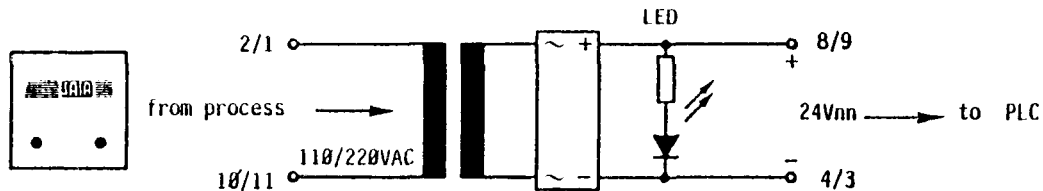

#### Technical data

Input voltage	220V, 50...60 Hz $\pm$ 20% type KOM 111B D4 110V, 50...60 Hz $\pm$ 20% type KOM 111B C8
Input current	in each case 0.5A
Output voltage	24VDC pulsating
Output current	in each case max. 40mA
Reaction time	max. 10ms (acc. to phase length)
Surge voltage on process side	5kV, 1/50 $\mu$ s
Connection	11-way round socket
Order specification	KOM 111B D4 or C8 (see input voltage)

### B 2.3.2 Type KOM 121B Dual-relay-output interface

Electric isolation in this interface is achieved by relays, the contacts of which are able to directly switch mains voltages. The normally-open contact to the relay is used corresponding to the PLC output.

Front

Switching scheme (per channel)

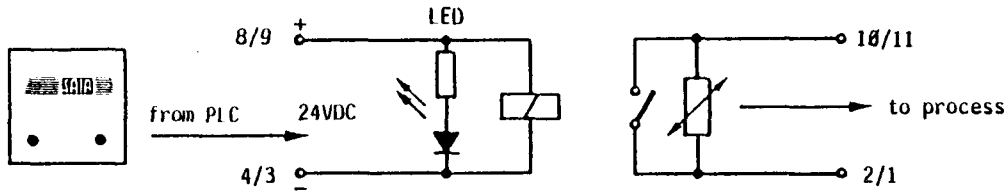

#### Technical data

Input voltage	24VDC $\pm$ 20%, smoothed or pulsating
Input current	20mA respectively
Relay contact	1 normally-open contact with hard silver contacts respectively
Switching power	6A, 250VAC AC1 1A, 250VAC AC11 respectively
Contact life (AC1)	3A, 220VAC 0.1 mio. switching cycles 1.5A, 220VAC 0.5 mio. switching cycles 0.3A, 220VAC 5 mio. switching cycles
Order specification	KOM 121B M4

B 2.4 Dimensions of additional units

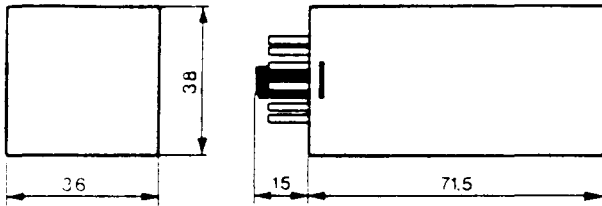

External interfaces  
KOM 111B and 121B

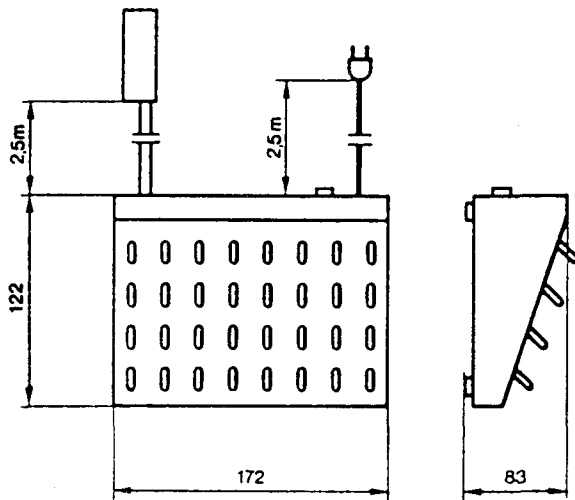

Input simulation unit  
PCA2.S10

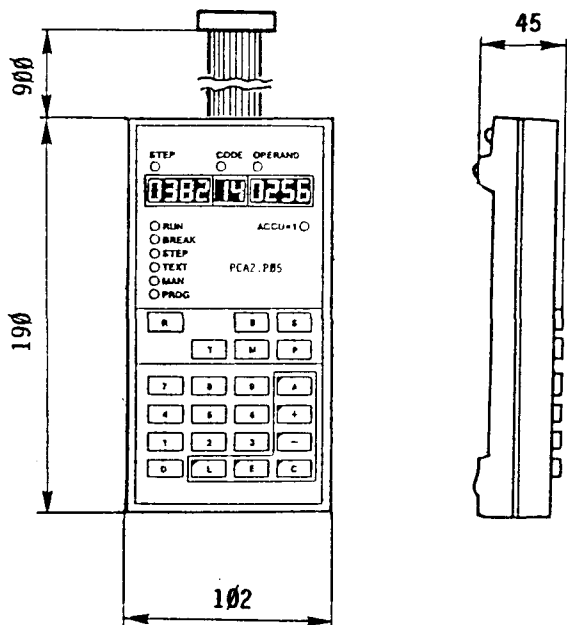

Programming unit  
PCA2.P05



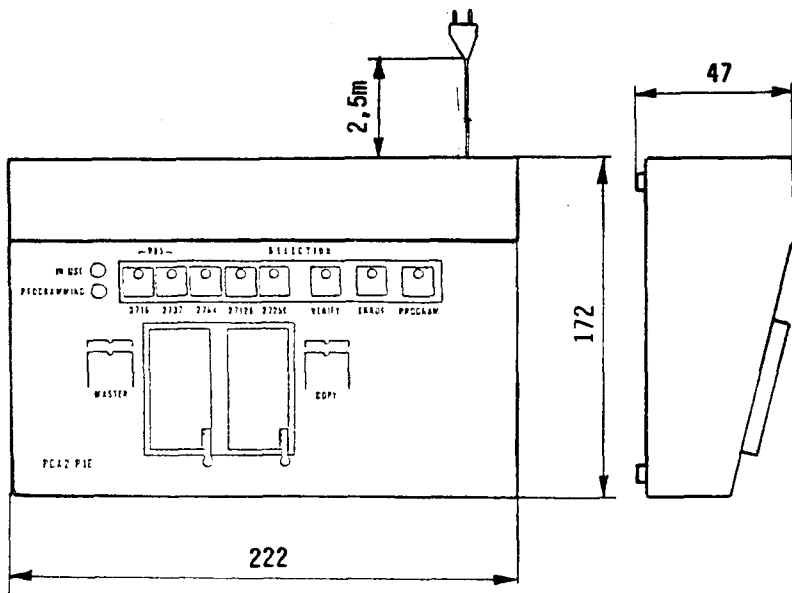

EPROM-copying unit  
PCA2.P16

**B 2.5 Dimensions and installation of PCA2.D12**

The display module can be installed in any position desired anywhere in a control cabinet door or an operating panel.

The display can be fastened in three ways:

<p>Dimensions</p>		
<p>Opening for installation valid for both assembly types</p>		
<p>Fastening with clamping spring</p>		<p>Standard version</p>
<p>Fastening with frontal frame and 2 countersunk screws M3/90°. with vertical frontal frame</p>	<p>Assembly type, vertical</p>	<p>Accessories Order no. 4'108'3671'0</p>
<p>with horizontal frontal frame</p>	<p>Assembly type, horizontal</p>	<p>Order no. 4'108'3672'0</p>

### B 2.6 Dimensions and installation of PCA2.D14

The display module can be installed in any location desired.

It can be fastened in two ways:

- with a clamping spring
- with a frontal frame and screws

(The clamping spring and the frontal frame are supplied with every PCA2.D14).

#### Dimensions

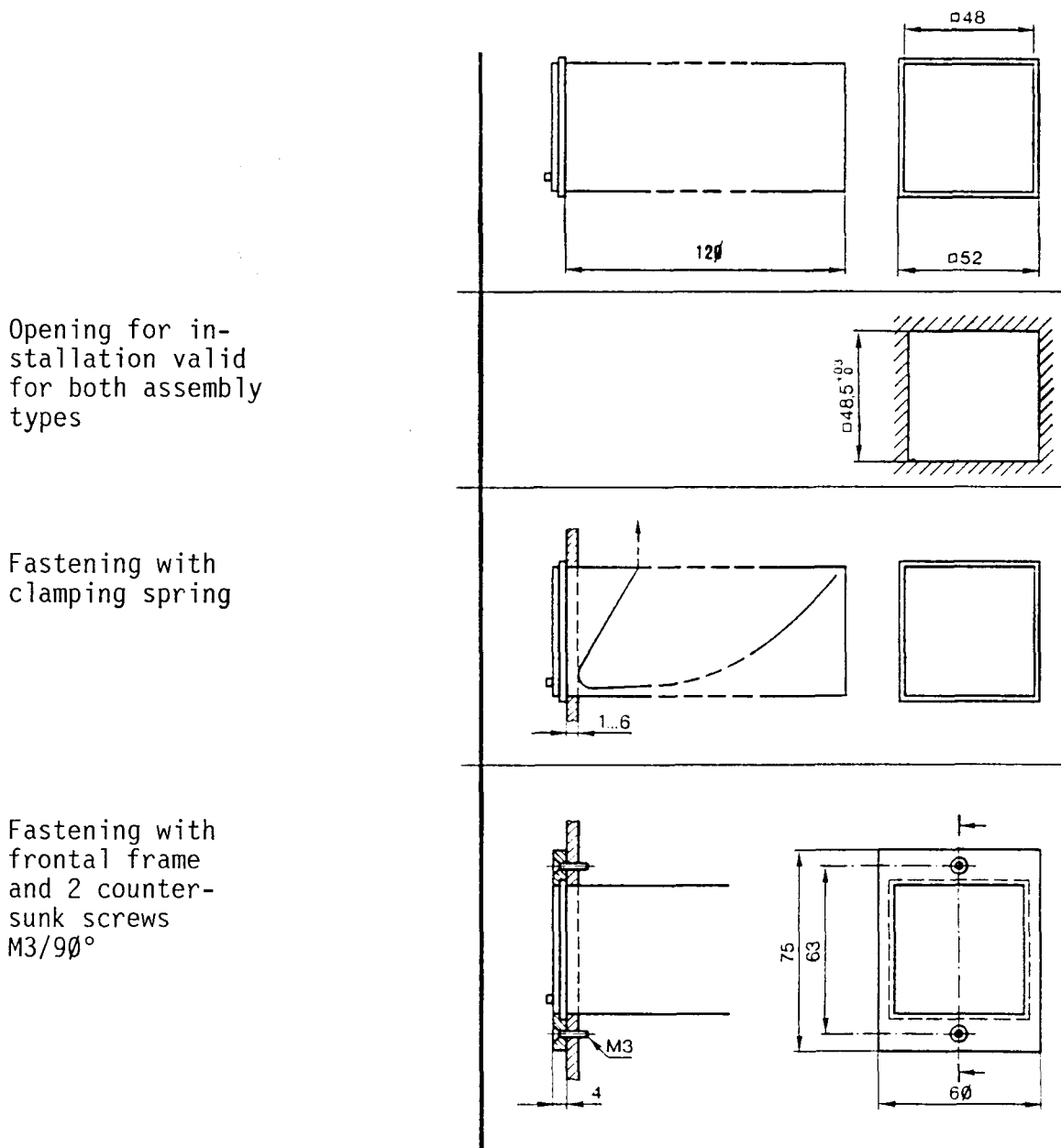

## **PART C OPERATING MODES**

### **C 1 Basic operating modes**

- RUN**
- PROG**
- MAN (Bit)**
- STEP**
- BREAK**

#### **C 1.1 Summary of operating modes**

#### **C 1.2 Detailed description of operating modes**

### **C 2 Further operating modes (only for PCA2.M22/M32)**

#### **C 2.1 TEST**

#### **C 2.2 MAN or MAN BIT**

#### **C 2.3 TEXT or text memory as data register**

#### **C 2.4 MAN BCD**

#### **C 2.5 LCM**

#### **C 2.6 List of modules**



General

In addition to the operating modes "programming" (PROG) and "normal program execution" (RUN), further useful operating modes are available for starting up and servicing. For this, only the compact programming unit PCA2.P05 is required for all SAIA<sup>®</sup>PLC.

PCA2.M21

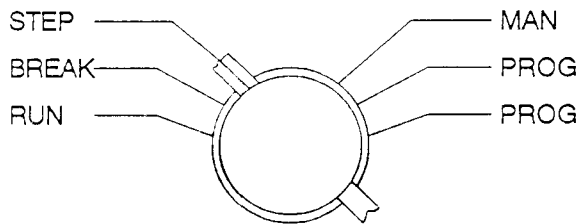

The operating modes are selected with the operating mode/selector switches opposite on all processor modules of the PCA2 series. The selector switch is only active when a programming unit is plugged into the PGU connector.

PCA2.M22

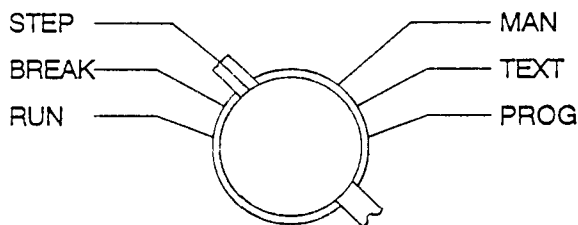

PCA2.M32

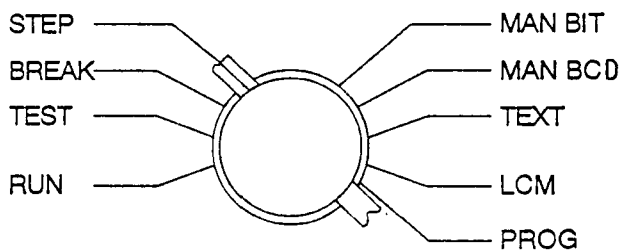

Display of the selected operating mode

Keys for selecting operating modes have no function on PCA2

PCA2.P05

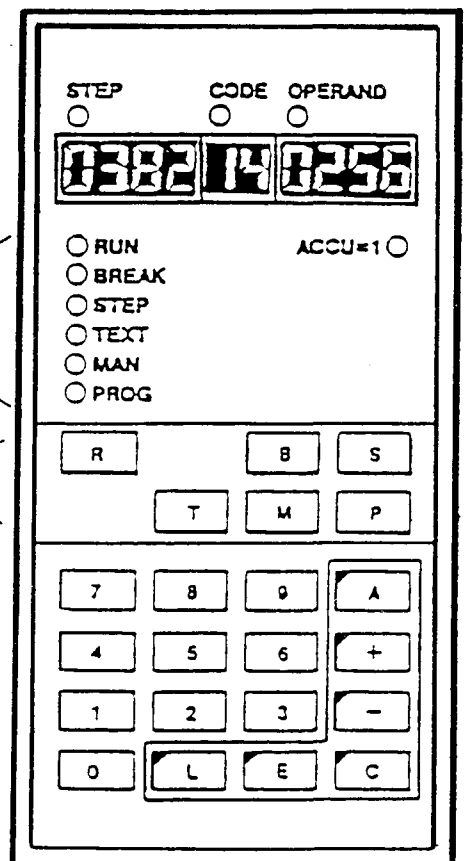

C 1 Basic operating modes

- RUN        Normal program processing
- PROG       A user program can be loaded into a RAM memory
- MAN        Manual interrogation and setting of elements  
(inputs, outputs, flags, timers, counters)
- STEP       Jump to a preselected step address (program  
line) of the user program and step-by-step  
operation
- BREAK      Program processing up to a set "breakpoint"  
and subsequent step-by-step operation

## C 1.1 Summary of operating modes

### RUN Normal program execution

The PCA2 is automatically in the RUN-mode when switching on if no programming unit is connected.

### PROG Programming

A program can be stored in a RAM-memory (on the user socket of the PCA1) or overwritten (corrected).

<input type="checkbox"/> A	Step	<input type="checkbox"/> E	Code	Operand	
	x x x x		x x	x x x x	
		<input type="checkbox"/> E	x x	x x x x	or <input type="checkbox"/> C to delete a wrongly entered line
		<input type="checkbox"/> +	Terminates the input.		
Test program	<input type="checkbox"/> + <input type="checkbox"/> +	or	<input type="checkbox"/> - <input type="checkbox"/> -		

### MAN \*\* Manual testing or setting of elements

(Elements = inputs, outputs, flags, counters, timers)

Testing:  A  $\underbrace{\text{ x x x } }_{\text{Element address}}$   $\longrightarrow$  display of the logic state in the operand (0/1)

Setting:  A  $\underbrace{\text{ x x x } }_{\text{Element address}}$   E  I  $\longleftrightarrow$  or  0

**STEP**  +  $\longrightarrow$  Display showing where the program is.

Jump to the preselected step address of the user program

A 139  +  $\longrightarrow$  Program jumps to step 139, then

+  + ... Step-by-step execution of the program with the result of the logic operation being checkable ACC = 1\*. Switching to RUN is always possible.

In case of parallel programs, only the activated parallel program is executed in the STEP-mode.

### BREAK Interruption of the program run and subsequent step-by-step-operation

+  $\longrightarrow$  Display showing where the program is.

+  + ... Step-by-step execution of the program with the result of the logic operation being checkable ACC = 1\*. Switching to RUN is always possible.

In case of parallel programs, all programs are executed simultaneously (as in the RUN-mode).

Setting of a breakpoint

A 820  +  $\longrightarrow$  Program runs up to step 820, then

+  + .... step-by-step operation skipping the "critical" point.

\*) ACC = accumulator is used to indicate the result of the logic combination. If ACC = 1 (conditions of the logic combination fulfilled = 1), the following switching instructions are executed.

\*\*\*) If the address of a timer or counter is preceded by a 3 (e.g. 3260 for counter 260), the value of this register can be read or entered manually with  E value  +.



## C 1.2 Detailed description of the operating modes

**RUN**      Normal program processing  
 The PCA2 is automatically in the RUN-mode when switching on if no programming unit is connected.  
 For PCA14, the sliding switch must be in position RUN.

**PROG**    Programming  
 A program can be stored in a RAM memory (on the user plug-in socket of the PCA2) or overwritten (corrected).

	STEP	CODE	OPERAND
<input type="checkbox"/> A	xxxx	<input type="checkbox"/> E	xx      xxxx
		<input type="checkbox"/> E	xx      xxxx
		<input type="checkbox"/> C	Deletes a wrongly entered line
		<input type="checkbox"/> +	Terminates the input
		<input type="checkbox"/> + <input type="checkbox"/> +	or <input type="checkbox"/> - <input type="checkbox"/> - to display the program

**MAN**      Manual testing or setting of elements  
 (Elements = inputs, outputs, flags, counters, timers)

	STEP <sup>1)</sup>	OPERAND	
Testing:	<input type="checkbox"/> A    xxx	0/1	→ display of the logic state
Setting:	<input type="checkbox"/> A    xxx	<input type="checkbox"/> E	→ <input type="checkbox"/> 1 or <input type="checkbox"/> 0

### 1) STEP = Element address

If the address of a timer or counter is preceded by a 3 (e.g. 3260 for counter 260), the value of this register can be read or entered manually with:

A    3xxx     E    value     +,  -,  A,  E

For an example see following page.

Continued from footnote 1)

Example: Input of values 23419 or 127 into counters 290 or 291.

Input:	Display:	STEP	CODE	OPERAND
A 3290		3290	0Y	YYYY

Input:	Display:	STEP	CODE	OPERAND
A 3290		3290	0Y	YYYY
E 23419		3290	02	3419
E 127		3291	01	0027 (wrong input)*

Correction before storing

C		3291	00	0000
0	127*	3291	00*	0127
+				

\* Values <10'000 have to be preceded by a leading 0.

STEP +  $\longrightarrow$  Display showing where the program is.

Jump to the preselected step address of the user program

A 139 +  $\longrightarrow$  Program jumps to step 139

+ + ... step-by-step processing of the program with the linkage result being checkable:  $\star$  ACCU = 1 <sup>2)</sup>

Switching to RUN is always possible.  
In case of parallel program, only the activated parallel program is processed in the STEP mode.

BREAK Interruption of the program run and subsequent step-by-step operation

+  $\longrightarrow$  Display showing where the program is.

+ + ... step-by-step execution of the program with the linkage result being checkable:  $\star$  ACCU = 1 <sup>2)</sup>

Switching to RUN is always possible.  
In case of parallel programs, all programs are processed simultaneously (as in the RUN-mode).

Setting of a "breakpoint"

A 820 +  $\longrightarrow$  Program runs up to step 820 in slow RUN operation

+ + ... step-by-step operation over the "critical" point.

<sup>2)</sup> Accu ( = accumulator ) is used to indicate the status of the logic combination  
When LED lights up, the ACCU = 1 (conditions of the logic combination fulfilled, linkage result = 1) , and the following switching instructions are executed.

## C 2 Further operating modes (only for PCA2.M22 and M32)

### C 2.1 "TEST" = checking of the ACCU state of the bit processor in the RUN-mode (only PCA2.M32)

It is often of advantage to know the ACCU state of the bit processor at a certain program point in the RUN-mode.

Proceed as follows:

- Turn operating mode selector switch to position "TEST".
- Depress key  , followed by the step address for checking the ACCU. Each key must be depressed (approx. 0.5s) until the display has responded.
- In order to test the following step,  is depressed, for the preceding step  is depressed.
- The ACCU state is displayed in the CODE-field as follows:

- |   |  |   |
|---|--|---|
|   | CODE   |   |
|   | <div style="border: 1px solid black; display: inline-block; padding: 2px 5px;"> <input type="checkbox"/> <input type="checkbox"/> </div> |   |
| <ul style="list-style-type: none"> <li>. If the display is effected in the <u>left</u> digit, the selected step address is in the program part of the <u>word</u> processor.</li> </ul> |  | <ul style="list-style-type: none"> <li>If the display is effected in the <u>right</u> digit, the selected step address is in the program part of the <u>bit</u> processor.</li> </ul> |
- . If the display remains out, the program does not execute the step address.
  - . Display 0 means ACCU = 0
  - . Display 1 means ACCU = 1
  - . Display 2 means, that the ACCU-state rapidly oscillates between 0 and 1 (the display is updated every second).

Example: CODE  means that the ACCU = 1 and the selected address is in the bit program part.

Remark: Concerning the operating mode "TEST".  
The cycle time of the CPU in this operating mode is twice the cycle time in the operating mode "RUN", i.e. approx. 70µs instead of 35µs.

## C 2.2 "MAN" or "MAN BIT"

### Manual access to the software date-time

Processor module M32 is only equipped with a software date-time which stops in case of voltage failure. The hardware date-time of this module is activated by using memory module PCA2.R27 on the upper main memory location and by inserting jumper "R27". Processor module M22 comes equipped with hardware date-time.

All programming units allow direct access to the software date-time (reading and writing).

The following table shows the signification and the numerical range for the addresses 4000...4007.

Address	Meaning	Numerical range
4000	Week of the year	1...53
4001	Day of the week	1...7
4002	Year (1989=89)	0...99
4003	Month	1...12
4004	Day of the month (Feb = 28)*	1...31
4005	Hours	1...23
4006	Minutes	1...59
4007	Seconds	0...59

\*) Contrary to the hardware date-time R27, the software date-time does not take the leap years into account (February = 28 days).

You may enter a maximum of 2 digits which appear in the operand (see examples on the following page).

- Examples: Input for Thursday, June 2nd, 89, 10h 12min 45s

Input:	Display:	STEP	CODE	OPERAND
A 4000		4000	00	00YY
E 22*		4000	00	0022
E 4*		4001	00	0004
E 89		4002	00	0089
E 6*		4003	00	0006
E 2*		4004	00	0002
E 10		4005	00	0010
E 12		4006	00	0012
E 45		4007	00	0045
+				

After entering the seconds (4007), key  is depressed, provided that the input corresponds to the actual time. Do not press key  again, since otherwise the input of the calendar week is erased.

- Display:

Input:	Display:
A 4000	4000 00 0022 22nd week of the year
+	4001 00 0004 Thursday
+	4002 00 0089 1989
+	4003 00 0006 June
+	4004 00 0002 2
+	4005 00 0010 10h
+	4006 00 0012 12min
+	4007 00 0045 45s
	46s
	47s
	::
	::

\* Calendar week and day of the week must correspond to month and date!

C 2.3 "TEXT" or text memory as data register

Input and reading of texts in the text memory

Input of texts is effected on RAM 6264 or 8464 or on the buffered RAM modules PCA1.R92/95/96 which are plugged onto the text socket.

The following 2 possibilities are available:

- a) Using one of the PCA programming units, connected via the PGU connector.
- b) With a peripheral unit with current loop interface, connected to the serial data interface.

For detailed description refer to manual Software level 2.

Manual access to the text memory as data register (PAS 54 for M22 and M32, PAS 55 only for M32)

In order to understand the monitor function of the system program, the formats which are used for organizing the various registers must be brought to mind:

Counter register : binary 16 bits  
 Text memory : binary 8 bits or 16 bits  
 (as data register) or BCD 8 bits

For manual access to the text memory as data register the operating mode selector switch must be set to "TEXT".

It is advantageous to use the data register for CPU M32 which is accessible in the operating mode "MAN BCD" or with PAS 56/57 (see chapter C 2.4).

● Display of the text memory contents

- a) Immediate display of a character value of 8 bits (1 byte) in binary notation

Upon actuation of key **A**, and subsequent input of the character number to be displayed (0...8191), the stored value (0...255) is displayed in the operand field in binary notation.

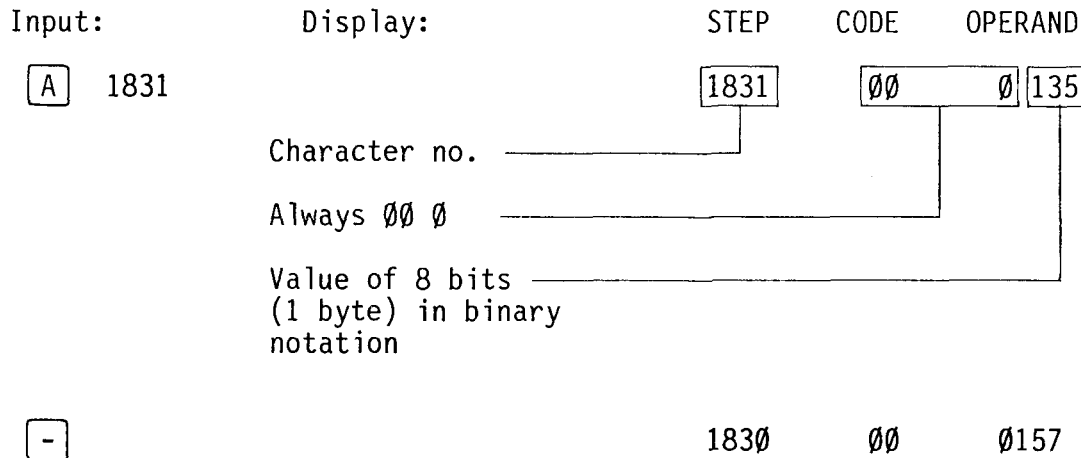

b) Display of the contents of 2 character no. (2 bytes = 16 bits) in binary notation

Actuating the key **C** once has the result that in addition to the selected character number the value of the preceding character can also be combined to form a 16-bit value (2 bytes) in binary notation. Consequently values in the range 0...65'535 can be displayed in the CODE and OPERAND field.

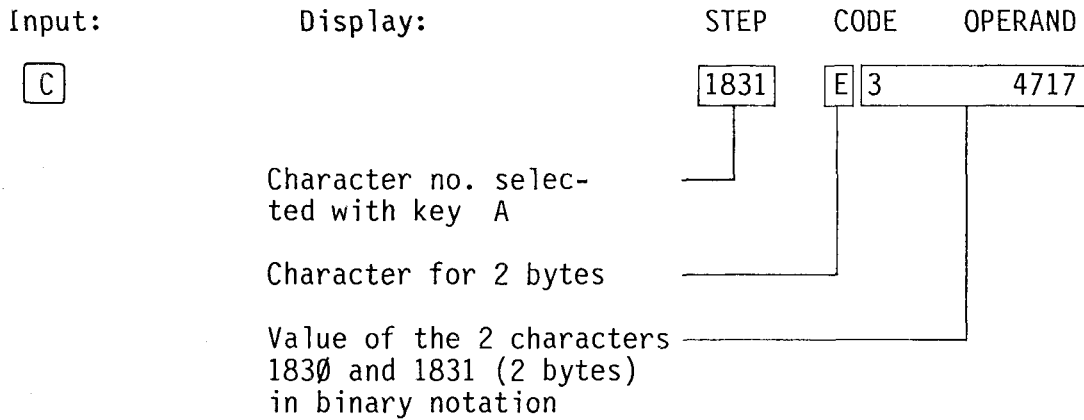

In such a way, the contents of transferred counters can be displayed with their total capacity of 16 bits.

c) Display of 1 character no. (1 byte = 8 bits) in BCD-notation

By actuating key **C** (convert) a second time, the bit pattern is displayed in BCD-notation.

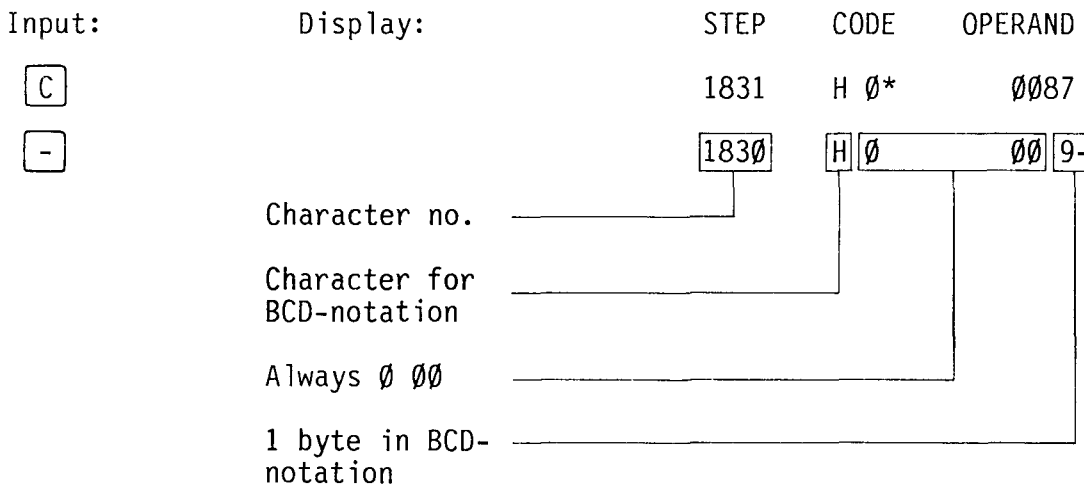

\*) Character in the code applies to P05. For P10 refer to the table on the following page.



Real BCD-bit patterns are displayed as decimals. If other characters are present as e.g. at character no. 1830, these are no BCD-bit patterns. In order to be able to interpret their values nevertheless, the following 7-segment characters are defined in the OPERAND:

Binary value	7-segment character	
	P10	P05
10		
11		
12		
13		
14		
15	blank	blank

● Manual data inputs into the text memory  
(limited RAM-memory in this area)

Key **A** : subsequent input of the character no., at which the value is to be stored

Key **E** : clears the old value and permits new input

Key **C** : before key **E** means "convert"  
after key **E** means "clear"

Key **+**, **-**, **A**, **E**: cause storage of the value introduced

Corresponding to the reading of data, 3 cases are distinguished for the manual input of data:

a) Input of a binary value of 1 byte (e.g. 48) at a character no.  
(e.g. 7436)

Input:	Display:	STEP	CODE	OPERAND
<b>A</b> 7436		7436	00	0XXX
<b>E</b> 48		7436	00	0048
<b>+</b>		7437	00	0YYY

b) Input of a binary value of 2 bytes (e.g. 1487) at character no. 7456 and 7457

Input:	Display:	STEP	CODE	OPERAND
[A] 7457 1)		7457	00	0XXX
[C]		7457	EY*	YYYY
[E] 1487 3)		7457	E1*	0487
[C] 01487		7457	E0*	1487
[+]		7459 4)	EZ*	ZZZZ

1) Always the higher address of a pair of 2 bytes is entered.

2) [C] before [E] results in the conversion to 2 bytes.

3) If values < 10'000 are entered, a 0 must be typed first.  
Correction with [C].

4) The character no. is automatically increased by 2.

c) Input of a BCD-value (e.g. 30) at character no. 7660 (in BCD-notation, only values from 0...99  $\cong$  1 byte can be entered)

Input:	Display:	STEP	CODE	OPERAND
[A] 7660		7660	00	0XXX
[C]		7660	EY*	YYYY
[C]		7660	H0*	00ZZ
[E] 30		7660	H0*	0030
[+]		7661	H0*	00AB

\*) Characters apply to PCA2.P05.

### C 2.4 "MAN BCD" = manual access to the word register as well as to the data register of the user memory (only for PCA2.M32)

#### Manually reading out and entering BCD-values into the word register

##### Display of a stored value

By depressing key **A** which is followed by the word address Rn (0...999) the value is displayed in the operand (2 digits).

##### Input of a value into the word register

- . Key **A** followed by the word address (0...999).
- . Key **E** clears the display and allows a new input.
- . The value is keyed in and terminated with **+**, **-**, **A**, **E**

##### Examples:

- The BCD-value 35 is to be entered at word address 510:

**A** 510 **E** 35 **+**

- The BCD-value 68 is to be entered at word address 174:

**A** 174 **E** 65 **C** 68 **+**

The value can be corrected with key "clear"

- The BCD-value 12'537 are entered at the word addresses 622, 623 and 624:

<b>A</b> 622	<b>E</b> 12	3	7	<table style="border-collapse: collapse;"> <tr><td style="border: 1px solid black; padding: 2px 5px;">R624</td></tr> <tr><td style="border: 1px solid black; padding: 2px 5px;">R623</td></tr> <tr><td style="border: 1px solid black; padding: 2px 5px;">R622</td></tr> <tr><td style="border: 1px solid black; padding: 2px 5px;">R621</td></tr> <tr><td style="border: 1px solid black; padding: 2px 5px;">R620</td></tr> </table>	R624	R623	R622	R621	R620
R624									
R623									
R622									
R621									
R620									
(623)	<b>E</b> 65	6	5	<table style="border-collapse: collapse;"> <tr><td style="border: 1px solid black; padding: 2px 5px;">R623</td></tr> <tr><td style="border: 1px solid black; padding: 2px 5px;">R622</td></tr> <tr><td style="border: 1px solid black; padding: 2px 5px;">R621</td></tr> <tr><td style="border: 1px solid black; padding: 2px 5px;">R620</td></tr> </table>	R623	R622	R621	R620	
R623									
R622									
R621									
R620									
(624)	<b>E</b> 37	1	2						
	<b>+</b>	0	0						
		0	0	} Value 12'65'37					

When reading the whole register block, check whether a 0 is at the addresses 620 and 621. Otherwise, 0 must be entered.

- The negative BCD-value -12'537 is to be entered using the register block R624:

Proceed as above, with the difference that a 9 is to be entered for the upper value of R620 which is evaluated as negative character by the processor.

<b>A</b> 620	<b>E</b> 90	3	7	<table style="border-collapse: collapse;"> <tr><td style="border: 1px solid black; padding: 2px 5px;">R624</td></tr> <tr><td style="border: 1px solid black; padding: 2px 5px;">R623</td></tr> <tr><td style="border: 1px solid black; padding: 2px 5px;">R622</td></tr> <tr><td style="border: 1px solid black; padding: 2px 5px;">R621</td></tr> <tr><td style="border: 1px solid black; padding: 2px 5px;">R620</td></tr> </table>	R624	R623	R622	R621	R620
R624									
R623									
R622									
R621									
R620									
(621)	<b>E</b> 0	6	5	<table style="border-collapse: collapse;"> <tr><td style="border: 1px solid black; padding: 2px 5px;">R623</td></tr> <tr><td style="border: 1px solid black; padding: 2px 5px;">R622</td></tr> <tr><td style="border: 1px solid black; padding: 2px 5px;">R621</td></tr> <tr><td style="border: 1px solid black; padding: 2px 5px;">R620</td></tr> </table>	R623	R622	R621	R620	
R623									
R622									
R621									
R620									
(622)	<b>E</b> 12	1	2						
		0	0						
		9	0	} Value - 12'65'37					

etc.

- A binary value is to be entered at word address 715:

$\underbrace{1100}_{C} \underbrace{0010}_{2}$  B (binary)  
 $\hat{=}$  C 2 H (hexa)  
 $\hat{=}$  194 D (decimal)  
 A 715  C  E 194  +

Key "C" (convert) causes conversion from BCD ---> binary of the value subsequently entered in BCD-representation. An acknowledgement is effected in the OPERAND by the character  194.

Note:

- Every input is terminated with  +,  - or  A.
- The above example shows that  C before  E results in the conversion of the input from BCD ---> binary or from binary ---> BCD. BCD-format is always selected by depressing  A.

Manually reading out and entering values into the data register of the user memory

The user memory of the M32 has a data memory of 8K times 8 bits, which can be accessed in the user program via the instructions PAS 56 and PAS 57. In order to be able to understand the supervisory function of the system program recall the representation of the various registers.

Counter register: binary 16 bits  
 Word register : BCD 8 bits or 5 x 8 bits  
 Text memory : binary 8 bits or 16 bits  
                   or BCD 8 bits

The word register and data register can be manually accessed in the operating mode "MAN BCD". In order to avoid conflicts with the 1023 word registers, the value 1100 must be added to the data addresses 0...8191 entered.

### Display of the data register contents

#### a) Display of a value of 8 bits (1 byte) in binary representation

The contents of data register 1831 is to be displayed:

By actuating key **A** and subsequently entering address 2931 ( $1831 + 1100$ ), the stored value ( $0\dots255$ ) is displayed in binary representation in the operand field.

Input:	Display:	STEP	CODE	OPERAND
<b>A</b> 2931		2931	00	0135
	Address of the data registers 1831 ( $2931 - 1100 = 1831$ )			
	Always 000			
	Value of 8 bits (1 byte) in binary representation			
<b>-</b>		2930	00	0157

#### b) Display of the contents of 2 data registers (2 byte = 16 bits) in binary notation

Actuating the key **C** (convert) once has the result that in addition to the selected data register, the value of the preceding register can be combined to form a 16 bit-value (2 bytes) in binary notation. As a result, values from  $0\dots65'535$  can be displayed in the CODE and OPERAND field.

Input:	Display:	STEP	CODE	OPERAND
<b>C</b>		2931	E3	4717
	Data register address 1831 selected with key A ( $2931 - 1100 = 1831$ )			
	Character for 2 bytes			
	Value of the 2 registers 1830 and 1831 (2 bytes) in binary notation			

In this way, the contents of transferred counters can be displayed with their total capacity of 16 bits.

c) Display of 1 data register (1 byte = 8 bits) in BCD-notation

By actuating key **C** (convert) a second time, the bit pattern is displayed in BCD-notation.

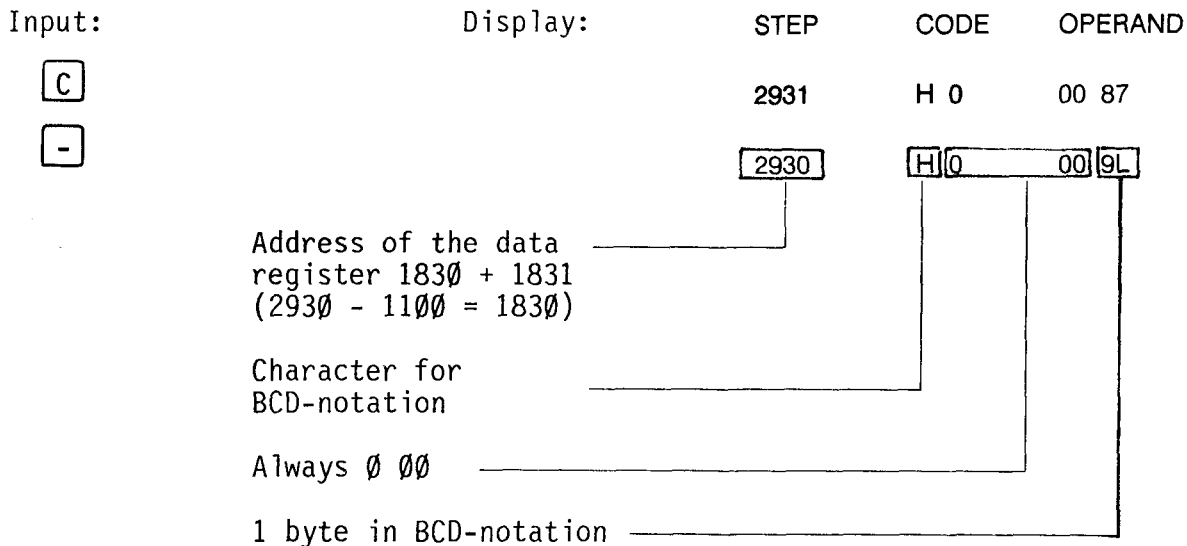

Real BCD-bit patterns are displayed as decimals. If other characters are present as e.g. in the data register 1830, these are no BCD-bit patterns. In order to be able to interpret their values nevertheless, the following 7-segment characters have been defined:

Binary value	Character BCD	
	P10	P05
10	☐	☐
11	☐	☐
12	☐	☐
13	☐	☐
14	☐	☐
15	blank	blank

The characters of the P05 are used in the explanations.

Manually entering data into the data register

(RAM-memory is required in this area)

Key **A** : Subsequently enter the data register address at which the value is to be stored (address = data register + 1100)

Key **E** : Clears the old value and permits new input

Key **C** : before key **E** means "convert"  
after key **E** means "clear"

Keys **+**, **-**, **A**, **E** : cause storage of the value introduced

As with reading of data, 3 cases can be distinguished when entering data manually.

- 1) Input of a binary value of 1 byte (e.g 48) into a data register  
(e.g. register 6336, addr. = 6336 + 1100 = 7436)

Input:	Display:	STEP	CODE	OPERAND
<b>A</b> 7436	7436		00	0XXX
<b>E</b> 48	7436		00	0048
<b>+</b>	7437		00	0YYY

- 2) Input of a binary value of 2 bytes (e.g. 1487) into the data registers  
6356 and 6357 (addr. = reg. + 1100)

Input:	Display:	STEP	CODE	OPERAND
<b>A</b> 7457 1)	7457		00	0XXX
<b>C</b> 2)	7457		EY *	YYYY
<b>E</b> 1487 3)	7457		E1 *	0487
<b>C</b> 01487	7457		E0 *	1487
<b>+</b>	7459 4)		EZ *	ZZZZ

1) Always the higher address of a pair of 2 bytes is entered.

2) **C** before **E** causes conversion to 2 bytes.

3) If values < 10'000 are entered, a 0 must be entered first.  
Correct with **C**.

4) The data register address is automatically increased by 2.

\*) For PCA2.P05

3) Input of a BCD-value (e.g. 30) into data register 6560 (in BCD-notation only values from 0...99  $\cong$  1 byte can be entered).

Input:	Display:	STEP	CODE	OPERAND
<input type="checkbox"/> A 7660 (6560 + 1100)		7660	00	0XXX
<input type="checkbox"/> C		7660	EY *	YYYY
<input type="checkbox"/> C		7660	H0 *	00ZZ
<input type="checkbox"/> E 30		7660	H0 *	0030
<input type="checkbox"/> +		7661	H0 *	00AB

---

\*) For PCA2.P05



### C 2.5 "LCM" = Load Copy Memory (only PCA2.M32)

- Virtually all memory modules can be used with PCA2.M32. The full capacity, however, is obtained only by using the modules R26 and R27.
- Copying is effected from the upper plug-in location of the CPU (main memory location) to the lower plug-in location (copy memory location). It is not important, whether programs or texts are copied. After transferring a program word, the contents are compared. If the contents of master and copy differ, the process will be stopped at once and the error address will be displayed.
- Two programs on two modules (RAM or EPROM) can be compared to each other in a similar way.

Examples:

. Input for copying

A 1200 (start address)  E 00 3800 (end address)  L "Load"

. Input for comparing the contents

A 1200 (start address)  E 00 3800 (end address)  C "COMPARE"

- Copying is effected at different speeds depending on the memory to be loaded:
  - . For loading into RAM (from RAM or EPROM) copying takes approx. 1s/1K.
  - . For loading into EPROM (from RAM or EPROM) copying takes approx. 100s/1K.

The CPU is able to choose the right speed itself by means of self-testing.

If a certain text area is to be copied, the text numbers must be converted to step addresses as follows:

Starting text no. x5           ≐ starting step address  
 Destination text no. x5 (+4) ≐ destination step address

Example:

Starting text no. 150           ≐ starting step address 750  
 Destination text no. 200       ≐ destination step address 1004

Note: Use power supply module PCA2.N30/31 and disconnect the I/O cards from the bus connectors for copying into EPROM.

## C 2.6 List of modules

Type	Chapter	Page
KOM 111B	B 2.3.1	85B
KOM 121B	B 2.3.2	86B
PCA-ASSEMBLER	B 2.1.4	64B
PCA1.R95/R96	B 2.1.6	70B
PCA2.A1Ø	B 1.2.1	14B
PCA2.A21	B 1.2.2	16B
PCA2.A31	B 1.2.3	18B
PCA2.A4Ø	B 1.2.4	21B
PCA2.C..	A 7	33A
PCA2.C21	A 7.1/A 7.2	33A
PCA2.C3Ø	A 7.2	34A
PCA2.D12	B 2.2.1	71B
PCA2.D13	B 2.2.2	78B
PCA2.D14	B 2.2.3	81B
PCA2.E1Ø	B 1.1.1	3B
PCA2.E11	B 1.1.2	6B
PCA2.E2Ø	B 1.1.3	7B
PCA2.E3Ø	B 1.1.4	9B
PCA2.E6Ø	B 1.1.5	12B
PCA2.F2Ø	B 1.5	45B
PCA2.H1..	B 1.4.1	36B
PCA2.H11	B 1.4.2	43B
PCA2.H12/H13	B 1.4.3	44B
PCA2.K..	A 8	35A
PCA2.M21	A 2	4A
PCA2.M22	A 3	10A
PCA2.M32	A 4	16A
PCA2.N2Ø/N21	A 6.1	28A
PCA2.N3Ø/N31	A 6.2	30A
PCA2.R26/R27	A 5	25A
PCA2.PØ5	B 2.1.1	61B
PCA2.P16	B 2.1.5	67B
PCA2.P18	B 2.1.3	63B
PCA2.S1Ø	B 2.1.2	62B
PCA2.W1..	B 1.3.1	24B
PCA2.W2..	B 1.3.2	31B

Notes:

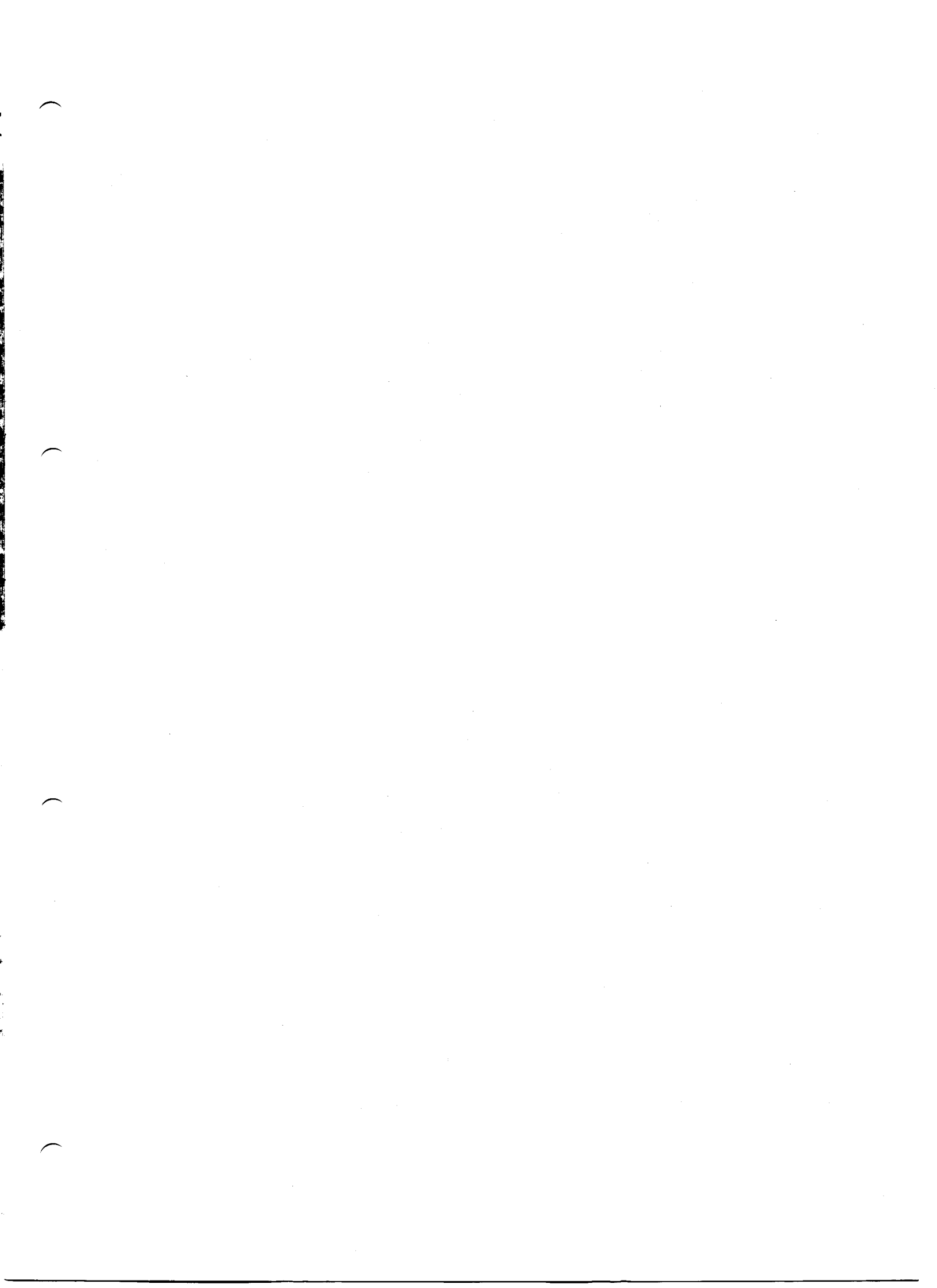

# SAIA AG

Industrial Electronics and Components  
3280 Murten/Switzerland

Telephone 037/727111  
Telefax 037/71 44 43  
Telex 942 127

## Further representatives

- Belgique** Landis & Gyr Belge SA, Dépt. Industrie  
Avenue des Anciens Combattants 190, B-1140 Bruxelles  
☎ 02/244 02 11, Tx 65 930, Fax 02/242 88 31
- Danmark** Skandia-Havemann  
Vallensbækvej 46, DK-2625 Vallensbæk  
☎ 02/64 33 33, Tx 33 383, Fax 02/64 22 45
- Deutschland** SAIA GmbH  
Flinschstrasse 67, D-6000 Frankfurt 60  
☎ 069/42 09 93-0, Ttx 69 99 375, Fax 069/42 56 54
- España** Landis & Gyr BC SA  
Batalla del Salado 25, Apartado 575, 28045 Madrid  
☎ 91/467 19 00, Tx 22 976, Fax 91/239 44 79
- France** SAIA Sàrl  
10, Blvd. Louise Michel, F-92230 Gennevilliers  
☎ 1/4086 03 45, Tx 613 189, Fax 1/47 91 40 13
- Great Britain** A.S.A.P. Ltd.  
Unit 15 D, Compton Place, Surrey Avenue, Camberley, Surrey GU15 3DX  
☎ 0276/691 580, Fax 0276/69 15 81
- Italia** Landis & Gyr SpA, Divisione Commerciale  
Via P. Rondoni 1, I-20146 Milano  
☎ 02/42 48.1, Tx 332 142, Fax 02/483 00 773
- Nederland** Landis & Gyr BV, Div. Electrowater  
Kampenringweg 45, Postbus 444, NL-2800 AK-Gouda  
☎ 01820/65 683, Tx 20 657, Fax 01820/32 437
- Norge** Malthe Winje & Co A/S  
Cort Adellersgt. 14, Postboks 2440, Solli, N-0202 Oslo 2  
☎ 02/55 86 40, Tx 19 629, Fax 02/55 22 11
- Österreich  
COMECON** Landis & Gyr Gesellschaft m. b. H  
Breitenfurterstrasse 148, Postfach 9, A-1230 Wien  
☎ 0222/84 26 26-0, Tx 132 706, Fax 0222/84 26 26 313
- Portugal** Infocontrol Electronica e Automatismo LDA.  
Av. da Igreja No. 68-1º Esq., P-1700 Lisboa  
☎ 01/77 51 61-65, Tx 63 454, Fax 01/77 56 87
- Suomi  
Finland** OY Landis & Gyr AB  
SF-02430 Masala  
☎ 8/0 297 31, Tx 100 11 53, Fax 8/0 297 5531
- Sverige** Beving Elektronik AB  
St. Eriksgatan 113a, Box 21 104, S-10031 Stockholm  
☎ 08/15 17 80, Tx 10 040, Fax 08/33 68 63
- USA** After sales services: Maxmar Controls Inc.  
99 Castleton Street, Pleasantville, New York 10570-3403  
☎ 914/747 3540, Fax 914/747 3567
- Australia** Landis & Gyr (Australia) Pty Ltd  
411 Ferntree Gully Road, P.O. Box 202, Mount Waverley, Vic. 3149  
☎ 3/544-2322, Tx 32 224, Fax 3/543 74 96
- Argentina** Electromedidor S.A.I. y C.  
Defensa 320, RA-1065 Buenos Aires  
☎ 1/33 7125, Tx 23 377, Fax 1/33 19 582