

**MOVIDRIVE® DFP21A Fieldbus Interface
PROFIBUS DP (12 MBaud)**

Edition

03/2001

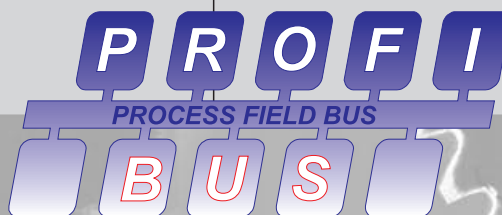

Manual

1051 6115 / EN

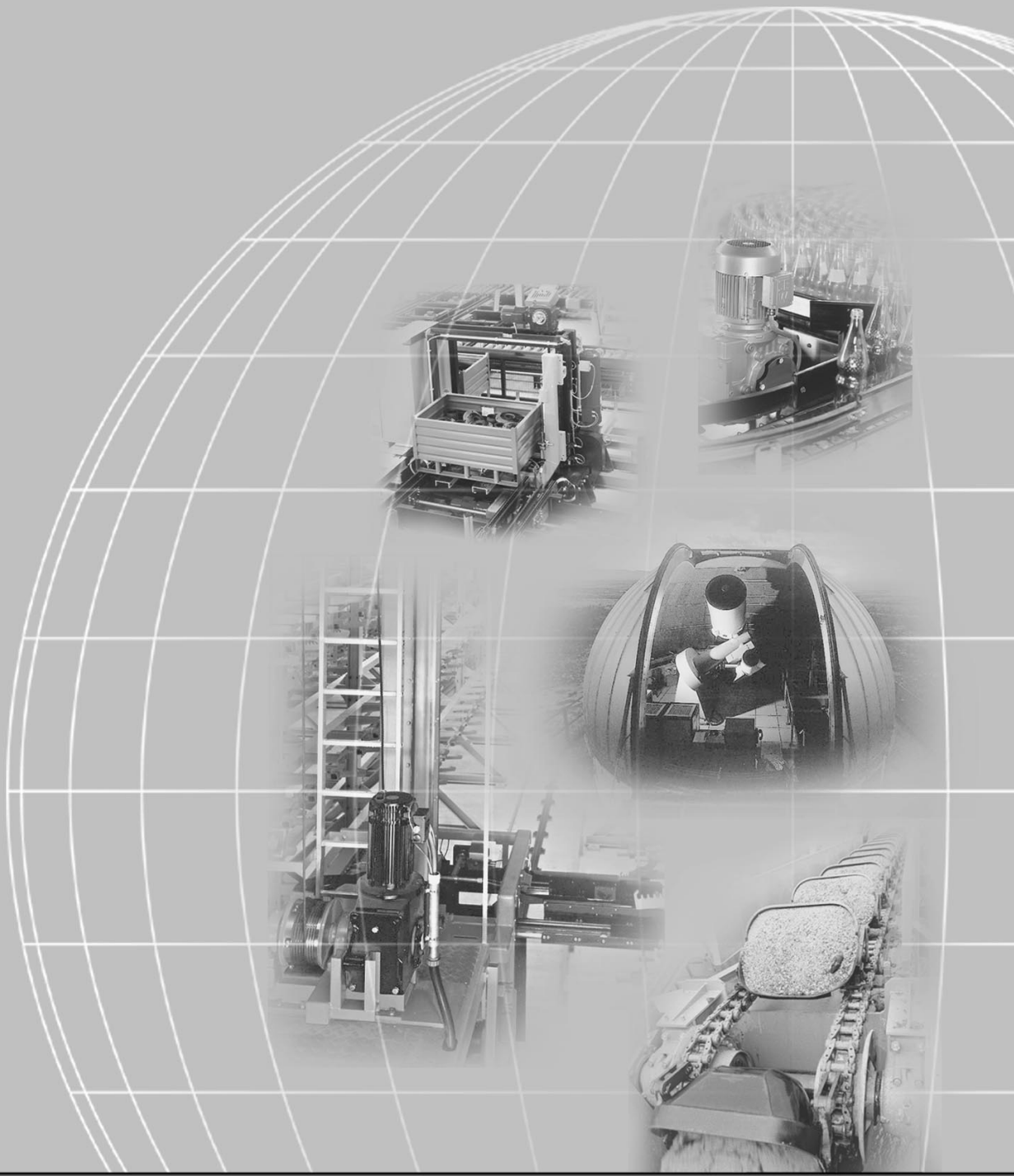

SEW-EURODRIVE

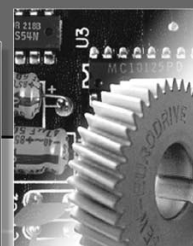
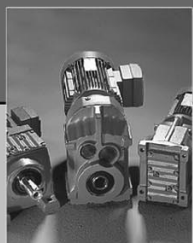



Contents

1	Introduction	4
2	DFP11A / DFP21A	6
2.1	Differences between DFP11A and DFP21A	6
2.2	Converting from DFP11 to DFP21	7
3	Assembly / Installation Instructions	8
3.1	Supported device types	8
3.2	Assembly of option card	8
3.3	Connector pin assignment	9
3.4	Shielding and routing of bus cables	10
3.5	Bus termination	11
3.6	Adjusting the station address	11
3.7	Display elements	12
3.8	GSD file	13
4	Project Planning and Startup	14
4.1	Project planning of DP master	14
4.2	External diagnostics	17
4.3	Startup of the drive inverter	19
5	Operating Performance at the PROFIBUS DP	22
5.1	Control of the drive inverter	22
5.2	PROFIBUS DP timeout	24
5.3	Fieldbus timeout response	25
5.4	Setting parameters via PROFIBUS DP	25
6	Parameter Setting Return Codes	31
6.1	Elements	31
6.2	Special cases	32
7	Troubleshooting	35
7.1	Diagnostics procedures	35
8	Technical Data	38
9	Index	39



1 Introduction

Contents of this manual

This manual accompanies the PROFIBUS (DFP) option and describes the installation of the PROFIBUS DFP option card in the drive inverter and the startup of MOVIDRIVE® on the PROFIBUS fieldbus system.

Additional documentation

The following documentation should be requested in addition to this manual for a simple and effective connection of MOVIDRIVE® to the PROFIBUS fieldbus system:

- MOVIDRIVE® Fieldbus Unit Profile Manual

The manual accompanying MOVIDRIVE® “Fieldbus Unit Profile” features a description of fieldbus parameters and related coding. It also features an explanation of the various control schemes and possible applications in form of small examples.

The MOVIDRIVE® “Fieldbus Unit Profile” manual contains a list of all parameters of the drive inverter that can be read and written via various communication interfaces such as the system bus, RS-485 and via the fieldbus interface.

Features

The MOVIDRIVE® drive inverter along with the DFP option and its high-performance universal fieldbus interface enables the connection to higher-level automation systems via PROFIBUS.

MOVIDRIVE® and PROFIBUS

The performance of the inverter (also referred to as the device profile) that forms the basis for the PROFIBUS operation, is fieldbus-independent and therefore uniform. This allows the user to develop fieldbus-independent drive applications. Thus, a change to other bus systems such as INTERBUS (DFI option) can easily be accomplished.

Access to all information

Use of the MOVIDRIVE® PROFIBUS interface offers digital access to all drive parameters and functions. Control of the drive inverter is achieved through the fast, cyclical process data. This process data channel makes it possible to initiate various drive functions such as release, controller inhibit, normal stop, quick stop, etc. and to specify setpoints such as setpoint speed, integrator time for acceleration/ramp down, etc. At the same time, this channel may also be used to read back actual values from the drive inverter, such as actual speed, current, device condition, error code or even reference messages.

Cyclical and acyclical data exchange

While the process data are generally exchanged in cycles, the drive parameters can also be read and written acyclically via functions such as READ and WRITE or the parameter channel. This exchange of parameter data enables applications where all important drive parameters are stored in the higher-level automation unit to be implemented, thus avoiding manual adjustment of parameters on the drive inverter itself, which can often be very time-consuming.



Configuring the PROFIBUS option card

In general, the PROFIBUS option card is designed so that all fieldbus-specific settings, such as the station address or default bus parameters, can be performed via hardware switch on the option card. Using this manual setting, the drive inverter can be integrated into the PROFIBUS and switched on quickly. Parameter setting can be performed automatically by the higher-level PROFIBUS master (parameter download). This trend-setting variant offers the advantage of reducing system startup time and simplifying the documentation of the application program since all important drive parameters can be stored directly in the control program.

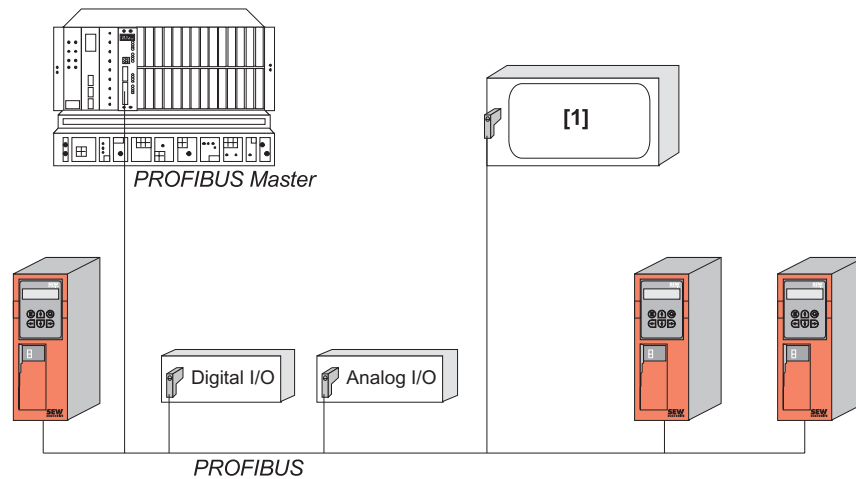

Figure 1: PROFIBUS with MOVIDRIVE® ([1] = visualization)

01061BXX

Monitoring functions

The use of a fieldbus system requires additional drive system monitoring such as time-monitoring of the fieldbus (fieldbus timeout) or even rapid stop concepts. The MOVIDRIVE® monitoring functions can be customized to your applications. The user can determine which error response the drive inverter should trigger in case of a bus error. A quick stop is useful for many applications, but the user can also cause a freeze of the last setpoints so that the drive runs continuously using the last valid setpoints (e.g. conveyor belt). Since the functionality of the control terminals is ensured in fieldbus operation, the user can still implement fieldbus-independent quick stop schemes via the drive inverter terminals.

Diagnostics

The MOVIDRIVE® drive inverter offers numerous diagnostic options for startup and service. Using the integrated fieldbus monitor, users can control setpoints sent from the higher-level controller as well as the actual values.

Fieldbus monitor

It also provides a lot of additional information on the status of the fieldbus option card. The fieldbus monitor function along with the MOVITOOLS® PC software, offer a convenient diagnostics option that allows not only the setting of all drive parameters (including the fieldbus parameters) but also a detailed display of the fieldbus and unit status information.



2 DFP11A / DFP21A

DFP21A is basically application-compatible with DFP11A, i.e. the use of the control program can be continued without modifications. However, **no FMS protocol** can be used with DFP21A.

Since the Profibus user group issued a new identification number and GSD file, a simple **replacement of the DFP11A with DFP21A without changing the DP master project planning is no longer possible**. The control program can be adopted without changes.

2.1 Differences between DFP11A and DFP21A

The following table shows the essential functions of the DFP11A and DFP21A options.

Functional feature	DFP11A	DFP21A
Maximum baud rate:	1.5 MBaud	12 MBaud
Bus terminating resistor:	integrated	via Profibus connector
Profibus FMS protocol:	YES	-
Profibus DP protocol:	YES	YES
Identification number:	6000 hex	6003 hex
GSD filename:	SEW_6000.GSD	SEW_6003.GSD
Module name for project planning:	"MOVIDRIVE+DFP11"	"MOVIDRIVE+DFP21"
Process data configurations:		
(Param) + 1 PD	YES	YES
(Param) + 2 PD	YES	YES
(Param) + 3 PD	YES	YES
(Param) + 6 PD	YES	YES
(Param) + 10 PD	YES	YES
Diagnostics information for DDLM_Slave_Diag:		
DP standard diagnostics	YES	YES
Unit-specific diagnostics (DP)	YES	YES



2.2 Converting from DFP11 to DFP21

Requirements

- The current GSD file for option DFP21A was imported into the DP master project planning program.
- If the inverter is the first or last participant of a Profibus segment – i.e. only one Profibus cable leads to the connector – a Profibus connector with integrated bus terminating resistor is required.

Procedure

Accept the address settings from the DIP switches

- On the DFP21A, use the DIP switches 2^0 through 2^6 to set the same Profibus address as preset on the DFP11A.
- Ignore the settings of the FMS/DP DIP switch since the DFP21A is a true PROFIBUS DP card.
- Set the lowest (unoccupied) “nc” DIP switch to OFF (factory setting).

Replacing option cards

- Remove the DFP11A option card and insert DFP21A into the left slot of the drive inverter.
- If the inverter is the first or last participant of a Profibus segment – i.e. only one Profibus cable leads to the connector – enable the bus terminating resistor in the Profibus connector.

Changing the DP master project planning

- Record the project planning data of the DFP11A (bus address, peripheral addresses, diagnostics alarm setting, etc.).
- Delete the project planning of the “MOVIDRIVE+DFP11” drive inverter.
- Add a new project planning with the name “MOVIDRIVE+DFP21.”
- Use the recorded project planning data of the “old” DFP11 project planning for the new DFP21A.
- Load the new project planning in the master system.

Restart of the bus system

- Switch on the 24 V support voltage of the drive inverter.
- Start the DP master.
- If the red *Bus Fault* LED = OFF, the DFP21 project planning in the DP master was performed successfully.



3 Assembly / Installation Instructions

3.1 Supported device types

The DFP option for connection to the PROFIBUS can be used with all drive inverters in the MOVIDRIVE® series.

3.2 Assembly of option card

- Before you begin**
- Remove electrostatic charge with appropriate measures (anti-static band, conductive shoes, etc.) before touching the option card.
 - Keep option card in its original packaging and remove it only when you are ready to install the option.
 - Avoid frequent touching of the option card and hold the card only at the edges. Do not touch any components.

Installation of option card

- Disconnect the supply voltage of the inverter. Switch off the supply voltage and the 24 V supply, if necessary.
- Remove lower cover from control unit.
- Unscrew electronics shield clamp.
- Remove black cover plate.
- Insert option card into guide rails of OPTION1 slot and push it into the slot.
- Apply moderate pressure to the front plate of the option card while pushing it into the slot. The card is seated correctly when it is level with the controller card.
- Fasten electronics shield clamp.
- Replace cover from control unit.
- Depending on the type of sub-D connector, the cover may not be installed. This fact does not affect the enclosure type of the device.
- The DFP option card is now completely installed.



Front view and components of DFP21A

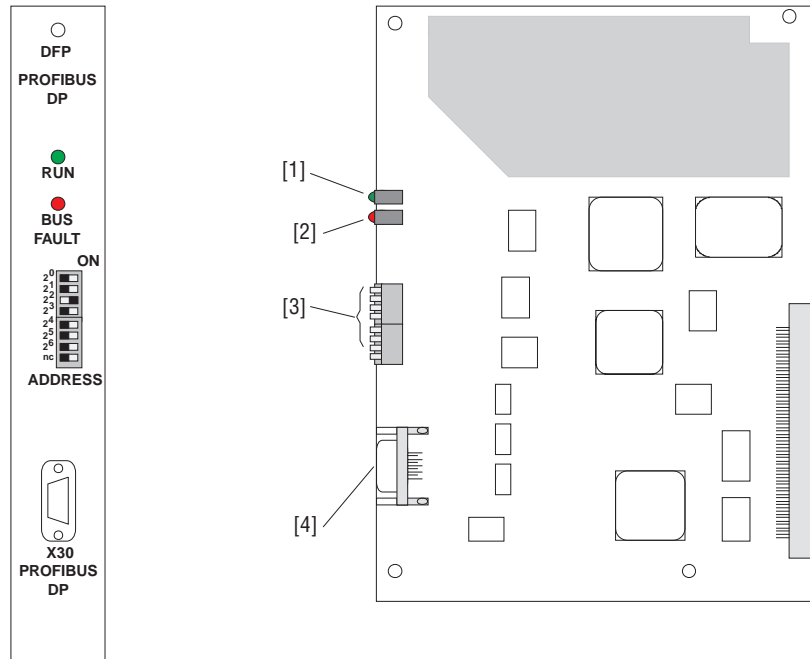

Figure 2: The DFP21A option

50257AXX

- [1] Green LED: RUN
- [2] Red LED: BUS FAULT
- [3] Bus address
- [4] 9-pole sub-D socket

3.3 Connector pin assignment

The MOVIDRIVE[®] drive inverter is connected to the PROFIBUS network by means of a 9-pole sub-D connector in accordance with EN 50170 (V2). The T-bus connection must be implemented using the appropriately designed connector or a bus terminal.

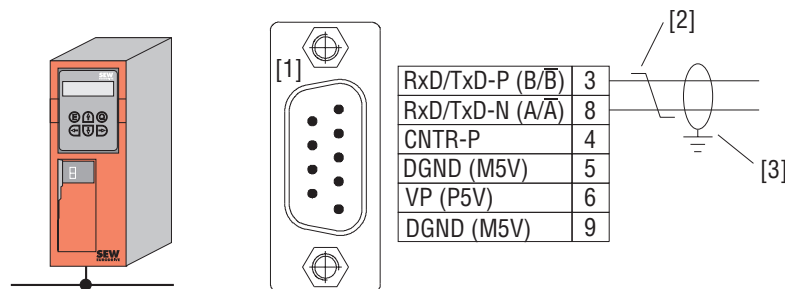

Figure 3: Connection of MOVIDRIVE[®] to PROFIBUS ([1] = 9-pole sub-D connector; [2] = twisted signal cable; [3] = conductive connection between connector plug housing and shield)

01222CXX



Pin number	Signal	RS-485 reference
1:	-	not assigned
2:	-	not assigned
3:	RxD/TxD-P	Receive/send data P
4:	CNTR-P	Repeater control signal (TTL)
5:	DGND	Data reference potential (5 V)
6:	VP	Supply voltage plus (P5V)
7:	-	not assigned
8:	RxD/TxD-N	Receive/send data N
9:	DGND	Data reference potential (5 V)
Housing	Shield of twisted-pair cable	

Connection of MOVIDRIVE® / PROFIBUS

The connection of the MOVIDRIVE® drive inverter to the PROFIBUS system is generally implemented using a shielded twisted-pair cable.

The twisted-pair cable is connected to the PROFIBUS receptacle via pin 8 (A/A') and pin 3 (B/B'). The communication is performed via these two contacts. The RS-485 signals A/A' and B/B' must be contacted the same way for all PROFIBUS participants. Otherwise, no communication is possible via the bus medium.

The PROFIBUS option card delivers a TTL control signal for a repeater or fiber optic link adapter (reference = pin 9) via pin 4 (CNTR-P).

Baud rates greater than 1.5 MBaud

The DFP21A can only be operated at baud rates of more than 1.5 MBaud with a special 12 MBaud Profibus connector!

3.4 Shielding and routing of bus cables

The PROFIBUS DFP option card supports the RS-485 communications protocol and requires a type A cable in accordance with EN 50170 (V2) as shielded twisted-pair cable for the physical connection.

Shielding properties

Professional shielding of the bus cables attenuates electrical interference that may occur in industrial environments. The following measures will enable you to obtain the best shielding properties:

- Tighten the mounting screws on the connectors, modules and equipotential bonding conductors by hand.
- Use connectors with metal housing or plated housing only.
- Connect the shielding in the connector with the greatest possible surface area.
- Place the shielding of the bus conductor on both sides.
- Do not route signal and bus cables parallel to line cables (motor leads). They must be routed in separate cable conduits.
- In industrial environments, use metal, grounded cable racks.
- Route the signal cable and the corresponding equipotential bonding in close proximity using the shortest way possible.



- Avoid extending bus lines by means of connectors.
- Route the bus cables closely alongside existing grounding areas.



CAUTION!

If ground potential fluctuations are present, a compensating current may flow via the shield that is bilaterally connected and connected with ground potential (PE). In this case, ensure that sufficient equipotential bonding is present in accordance with relevant VDE regulations.

3.5 Bus termination

The DFP21A is not equipped with bus terminating resistors to simplify startup of the bus system and reduce error sources during installation.

A connector with integrated bus terminating resistor must be used in case the drive inverter is located at the beginning or end of a PROFIBUS segment and only one PROFIBUS cable leads to the DFP21A.

Switch on the bus terminating resistors at this PROFIBUS connector.

3.6 Adjusting the station address

The PROFIBUS station address is set using the DIP switches on the option card. PROFIBUS supports the address range from 0 through 125.

It is not possible to change the PROFIBUS station address via DIP switches during operation of the drive inverter. The modified station address will only become effective after the drive inverter is switched off and on again (supply voltage + 24 V OFF/ON).

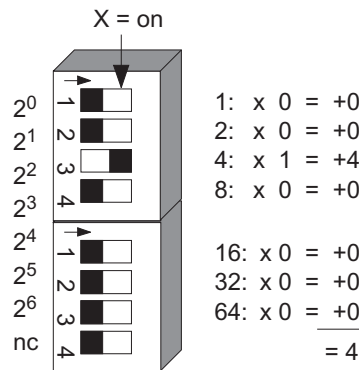

50232AXX

Figure 4: Setting the PROFIBUS station address / nc = reserved, position OFF



The following table uses address 17 as example to show how the DIP switch settings are determined for any bus address. Divide the desired bus address by two and note the remainder which may be only 0 or 1. This remainder also represents the setting of the DIP switches.

Table 1: Example for determining the DIP switch settings for bus address 17

Calculation	Remainder	DIP switch setting	Valence
$17 \div 2 = 8$	1	X1 = 20 = ON	1
$8 \div 2 = 4$	0	X2 = 21 = OFF	2
$4 \div 2 = 2$	0	X3 = 22 = OFF	4
$2 \div 2 = 1$	0	X4 = 23 = OFF	8
$1 \div 2 = 0$	1	X5 = 24 = ON	16
$0 \div 2 = 0$	0	X6 = 25 = OFF	32
$0 \div 2 = 0$	0	X7 = 26 = OFF	64

The current PROFIBUS station address can be controlled with parameter *P092 Fieldbus Address*.

092	Fieldbus Address	4
------------	-------------------------	----------

3.7 Display elements

The DFP21A option offers two LEDs for diagnostic purposes:

- **RUN** LED signals the proper operation of the bus electronics
- **BUS-FAULT** LED to display faults at the PROFIBUS DP

Table 2: States of the RUN LED (green)

RUN	Fault cause	Fault correction
On	<ul style="list-style-type: none"> • PROFIBUS hardware OK. 	-
Off	<ul style="list-style-type: none"> • A hardware problem exists in the bus electronics. 	<ul style="list-style-type: none"> • Switch MOVIDRIVE® on again. If the fault occurs again, contact SEW service for support.
Flashing	<ul style="list-style-type: none"> • PROFIBUS address is set higher than 125. 	<ul style="list-style-type: none"> • Use <i>P093 Fieldbus Address</i> to check the address set with the DIP switches.



Table 3: States of the BUS FAULT LED (red) with RUN LED = On

BUS FAULT	Fault cause	Fault correction
On	<ul style="list-style-type: none"> • Connection to the DP master has failed. • The device does not detect any PROFIBUS baud rate. • Possible bus interruption. • DP master is not operating. 	<ul style="list-style-type: none"> • Check the PROFIBUS DP connection of the device. • Check the project planning in the DP master. • Check all cables in your PROFIBUS DP network.
Off	<ul style="list-style-type: none"> • The device is currently exchanging data with the DP master (data exchange state). 	-
Flashing	<ul style="list-style-type: none"> • Device detected the baud rate; however, it is not addressed by the DP master. • Device was not configured in DP master or configured incorrectly. 	<ul style="list-style-type: none"> • Check the preset PROFIBUS address on the DFP21 and in the project planning software of the DP master. • Check the project planning of the DP master. • Use the GSD file SEW_6003.GSD with the identification <i>MOVIDRIVE-DFP21</i> for the project planning.

3.8 GSD file

A GSD file is available for the project planning of the DP master. This file must be copied to a special directory of your project planning software.

The detailed installation procedure can be found in the manuals of the corresponding project planning software.

The device master files standardized by the PROFIBUS user organization can be read by all PROFIBUS DP masters.

Table 4: GSD file of DFP21A

Project planning tool	DP Master	File name
All DP project planning tools in accordance with EN 50170 (V2)	for Standard DP Master	SEW_6003.GSD
Siemens S7 hardware configuration	for all S7 DP Masters	
Siemens S5 COM PROFIBUS	for IM 308C and others	



The latest versions of the SEW GSD files are always located on SEW's Internet pages at the following address:

<http://www.sew-eurodrive.com>



The entries in the GSD file may not be modified or expanded. No liability is accepted for any malfunctions of the inverter due to a modified GSD file!



4 Project Planning and Startup

This section features information about the project planning of the DP master and the startup of the drive inverter for fieldbus operation.

4.1 Project planning of DP master

A GSD file is available for the project planning of the DP master. This file must be copied to a special directory of your project planning software.

The detailed installation procedure can be found in the manuals of the corresponding project planning software.

Project planning procedure

Perform the following procedure for the project planning of MOVIDRIVE® with PROFIBUS DP interface:

1. Read the file *README_GSD6003.PDF* that accompanies the GSD file to obtain additional updated information about the project planning.
2. Install (copy) the GSD file according to the requirements of your project planning software. Once the installation has been completed correctly, the device appears in the slave stations with the designation *MOVIDRIVE+DFP21*.
3. Now insert the interface module under the name *MOVIDRIVE+DFP21* in the PROFIBUS structure for the project planning and assign the station address.
4. Select the process data configuration required for your application (see also “DP Configurations” section).
5. Enter the I/O or peripheral addresses for the configured data widths.

After the project planning has been completed, the PROFIBUS DP may be put into operation. The red “*BUS-FAULT*” LED signals the state of the project planning (OFF = project planning is OK).

DP configurations

The drive inverter must be given a specific DP configuration by the DP master to define type and number of input and output data used for the transmission. The following options are available:

- control the drive via process data,
- read or write all drive parameters via parameter channel,
- use a freely definable data exchange between IPOS^{plus}® and controller.

MOVIDRIVE® drive inverters allow for different DP configurations for the data exchange between DP master and inverter. The following table gives additional information for all available DP configurations in the MOVIDRIVE® series. The “Process data configuration” column shows the name of the configuration. These texts also appear as a selection list in the project planning software for the DP master. The “DP configurations” column shows the type of configuration data sent to the inverter while the link to PROFIBUS DP is being established.



Table 5: DP configurations of DFP21A

Process data configuration	Meaning / notes	DP configurations*	
		0	1
1 PD	MOVIDRIVE® control via 1 process data word	240 _{dec}	-
2 PD	MOVIDRIVE® control via 2 process data words	241 _{dec}	-
3 PD	MOVIDRIVE® control via 3 process data words	242 _{dec}	-
6 PD	MOVIDRIVE® control via 6 process data words (PD4-PD6 can only be used with IPOS ^{plus} ®)	0 _{dec}	245 _{dec}
10 PD	MOVIDRIVE® control via 10 process data words (PD4-PD10 can only be used with IPOS ^{plus} ®)	0 _{dec}	249 _{dec}
Param + 1 PD	MOVIDRIVE® control via 1 process data word Parameter setting via 8-byte parameter channel	243 _{dec}	240 _{dec}
Param + 2 PD	MOVIDRIVE® control via 2 process data words Parameter setting via 8-byte parameter channel	243 _{dec}	241 _{dec}
Param + 3 PD	MOVIDRIVE® control via 3 process data words Parameter setting via 8-byte parameter channel	243 _{dec}	242 _{dec}
Param + 6 PD	MOVIDRIVE® control via 6 process data words Parameter setting via 8-byte parameter channel (PD4-PD10 can only be used with IPOS ^{plus} ®)	243 _{dec}	245 _{dec}
Param + 10 PD	MOVIDRIVE® control via 10 process data words Parameter setting via 8-byte parameter channel (PD4-PD10 can only be used with IPOS ^{plus} ®)	243 _{dec}	249 _{dec}

Universal DP configuration

Selecting the DP configuration “Universal Module” (S7 HWKonfig) offers the option to perform a user-specific DP configuration while adhering to the following boundary conditions.

Module 0 (DP identifier 0) defines the parameter channel of the inverter.

The parameter channel should always be transmitted consistently over the complete length to ensure a proper setting of the parameters.

Length	Function
0	Parameter channel switched off
8 I/O bytes or 4 I/O words	Parameter channel is used

Module 1 (DP identifier 1) defines the process data channel of the inverter.

In addition to the process data configurations predefined in the GSD file, the process data configurations can also be specified with 4, 5, 7, 8 and 9 process data words. It should be observed that the number of input and output words is always identical. If the lengths are different, no data exchange is possible. In this case, the bus fault LED remains flashing in the state and the *P090 PD configuration* parameter indicates the configuration fault with **0PD**.



Length	Function
2 I/O bytes or 1 I/O word	1 process data word
4 I/O bytes or 2 I/O words	2 process data words
6 I/O bytes or 3 I/O words	3 process data words
8 I/O bytes or 4 I/O words	4 process data words
10 I/O bytes or 5 I/O words	5 process data words
12 I/O bytes or 6 I/O words	6 process data words
14 I/O bytes or 7 I/O words	7 process data words
16 I/O bytes or 8 I/O words	8 process data words
18 I/O bytes or 9 I/O words	9 process data words
20 I/O bytes or 10 I/O words	10 process data words

The following figure shows the structure of the configuration data defined in EN 50170(V2). The configuration data are transmitted to the drive inverter during the initial start of the DP master.

Table 6: Format of the identification byte *Cfg_Data* in accordance with EN 50170 (V2)

7 / MSB	6	5	4	3	2	1	0 / LSB
				Data length 0000 = 1 byte/word 1111 = 16 bytes/words			
				Input/output 00 = special identification formats 01 = input 02 = output 11 = input/output			
				Format 0 = byte structure 1 = word structure			
Integrity over 0 = byte or word 1 = complete length							



Note:

MOVIDRIVE® does not support the coding “Special identification formats!”
 For data transmission, use only the setting “Integrity over complete length!”

**Data integrity**

Integral data is data that must always be transmitted consistently between automation device and drive inverter and may never be transmitted in separated form.

Data integrity is especially important for the transmission of positioning values or complete positioning tasks since an inconsistent transmission may feature data from different program cycles of the automation device and, therefore, may transfer undefined values to the drive inverter.

For PROFIBUS DP, the data communication between automation device and drive engineering devices is generally carried out with the setting “Data integrity over complete length.”

4.2 External diagnostics

For the MOVIDRIVE[®] MDx60 drive inverter with DFP21A option, the automatic generation of external diagnostic alarms via PROFIBUS DP can be activated during the project planning in the DP master. If this function is activated, the inverter reports an external diagnostics to the DP master with every occurring fault. In order to analyze the diagnostics information, it is necessary to program corresponding (and at times difficult) program algorithms in the DP master system.

Recommendation

Since MOVIDRIVE[®] transmits the current drive state via status word 1 with every PROFIBUS DP cycle, it is on principle not necessary to activate the external diagnostics.

The design of the device-specific diagnostics was redefined for Profibus DPV1. The mechanism described below can only be used with Profibus DP (without DPV1 extensions). It is recommended not to use this mechanism for new applications.

**Note on Simatic S7 master systems!**

Diagnostic alarms may also be triggered by the PROFIBUS-DP system in the DP master at any time if the external diagnostic generation is deactivated. As a result, the corresponding operation blocks (e.g., OB84 for S7-400 or OB82 for S7-300) should always be created in the controller.

Procedure

Additional application-specific parameters can be defined in every DP master during the project planning of a DP slave. These parameters are transferred to the slave when the PROFIBUS-DP is running up. Nine application-specific parameter data are provided for MOVIDRIVE[®] that feature the following functions:



Table 7: Application-specific parameter setting data for MOVIDRIVE® + DFP21

Byte:	Permitted value	Function
0	00 hex	Reserved for DPV1
1	00 hex	Reserved for DPV1
2	00 hex	Reserved for DPV1
3	06 hex	Structured user parameter block with 6 byte length
4	81 hex	Structure type: user (manufacturer-specific)
5	00 hex	Slot number: 0 = complete device
6	00 hex	Reserved
7	01 hex	SEW user parameter version: 1
8	00 hex	DFP21 generates diagnostic alarm in the case of a malfunction
	01 hex	DFP21 does not generate a diagnostic alarm in the case of a fault (factory setting)

All unlisted values are not permitted. They can lead to malfunctions of the DFP21!

Project planning example

The project planning programs of the DP master systems offer the possibility to either activate the diagnostics in plain text, for example through the use of STEP7 (Figure 5), or to specify it directly as hex code (Table x).

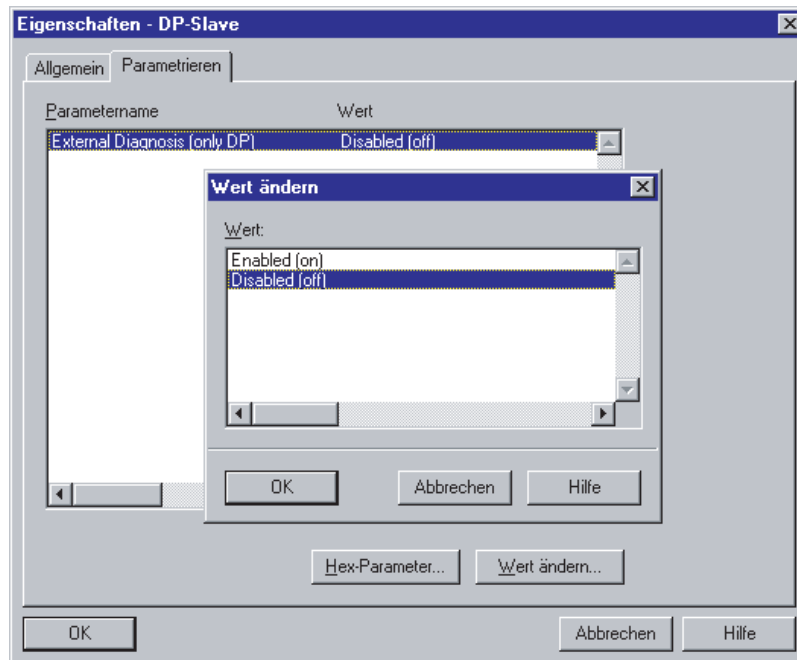

Figure 5: Activating the external diagnostics with STEP7

50256AXX



Table 8: Hex code for activating the external diagnostics generation

Parameter setting data (hex)	Function
00, 00, 00, 06, 81, 00, 00, 01, 00	Diagnostic alarms are also generated if there is a fault. (enabled = on)
00, 00, 00, 06, 81, 00, 00, 01, 01	Diagnostic alarms are not generated if there is a fault. (disabled = off, factory setting)

4.3 Startup of the drive inverter

After installing the PROFIBUS option card, you can immediately set parameters in the MOVIDRIVE[®] drive inverter via the PROFIBUS system without any additional settings. For example, after power-on all parameters of the higher-level programmable controller can be set.

However, in order to control the drive inverter via PROFIBUS, it must first be switched to the control (P101) and setpoint source (P100) = FIELDBUS. Using the FIELDBUS setting, the drive inverter is parameterized to the setpoint transfer from the PROFIBUS. The MOVIDRIVE[®] drive inverter now responds to the process output data sent by the higher-level programmable controller.

The activation of the FIELDBUS control and setpoint source is signaled to the higher-level controller using the “fieldbus mode active” bit in the status word.

For safety reasons, the drive inverter must also be enabled on the terminal side for control via fieldbus system. This means the terminals must be connected or programmed so that the inverter is released via input terminals. The simplest way of releasing the drive inverter at the terminal side consists of connecting the input terminal DIØØ (/CONTROLLER INHIBIT function) with a +24 V signal and programming the input terminals DIØ1 through DIØ3 to NO FUNCTION. The procedure for the startup of the MOVIDRIVE[®] drive inverter with fieldbus connection is described on the next page.



Procedure for startup of the MOVIDRIVE® drive inverter

1. Enable the power-circuit output module on the terminal side.

Connect input terminal DI00 / X13.1 (/CONTROLLER INHIBIT function) to a +24 V signal (via device jumper).

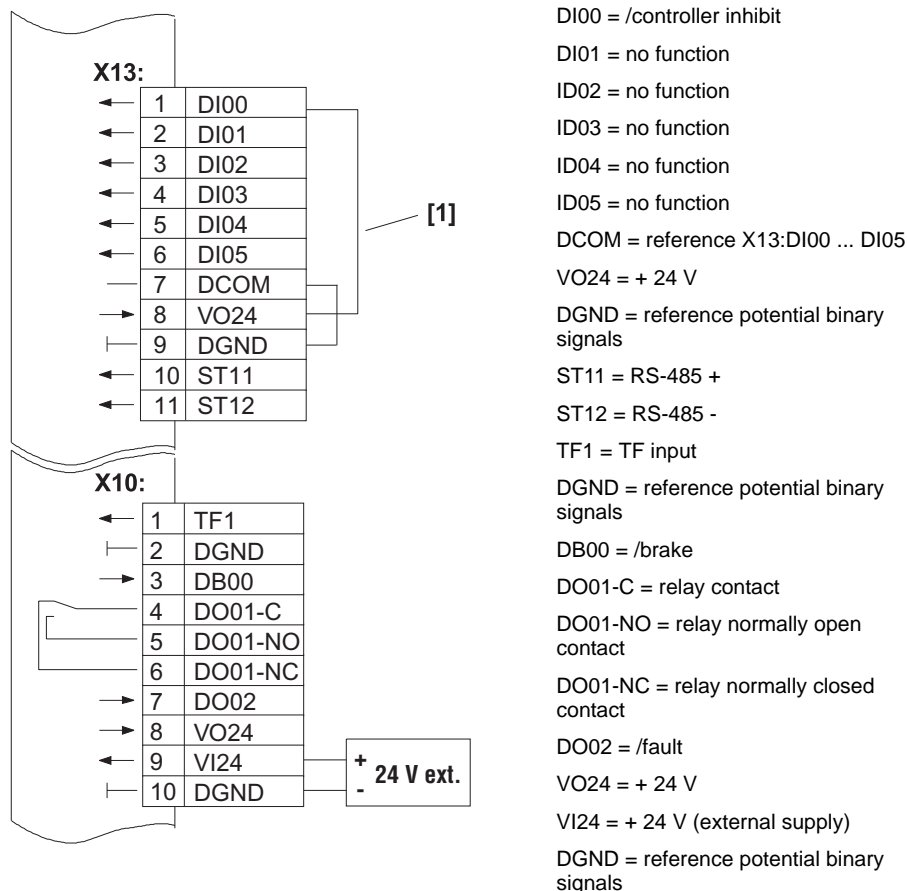

Enabling the power output stage via device jumper [1]

2. Switch on the 24 V voltage supply

Switch on the external 24 V power supply (not the supply voltage!) only so that the parameters of the drive inverter can be set.

3. Setpoint source = FIELDBUS / control source = FIELDBUS

Set the parameters of the setpoint source and the control source to FIELDBUS to control the drive inverter via fieldbus.

P100 setpoint source = FIELDBUS
--

P101 control source = FIELDBUS



4. Input terminals DIØ1 ... DIØ3 = NO FUNCTION

Program the functionality of the input terminals to NO FUNCTION.

P600 programming terminal DIØ1 = NO FUNCTION

P601 programming terminal DIØ2 = NO FUNCTION

P602 programming terminal DIØ3 = NO FUNCTION

Further information on startup and control of the MOVIDRIVE® drive inverter can be found in the manual accompanying the fieldbus unit profile.



5 Operating Performance at the PROFIBUS DP

This section describes the principal drive inverter performance at the PROFIBUS DP.

5.1 Control of the drive inverter

The control of the drive inverter takes place via the process data channel which is one, two or three I/O words in length. These process data words may be mapped in the I/O or peripheral area of the controller if a programmable controller is used as DP master and can be addressed as usual.

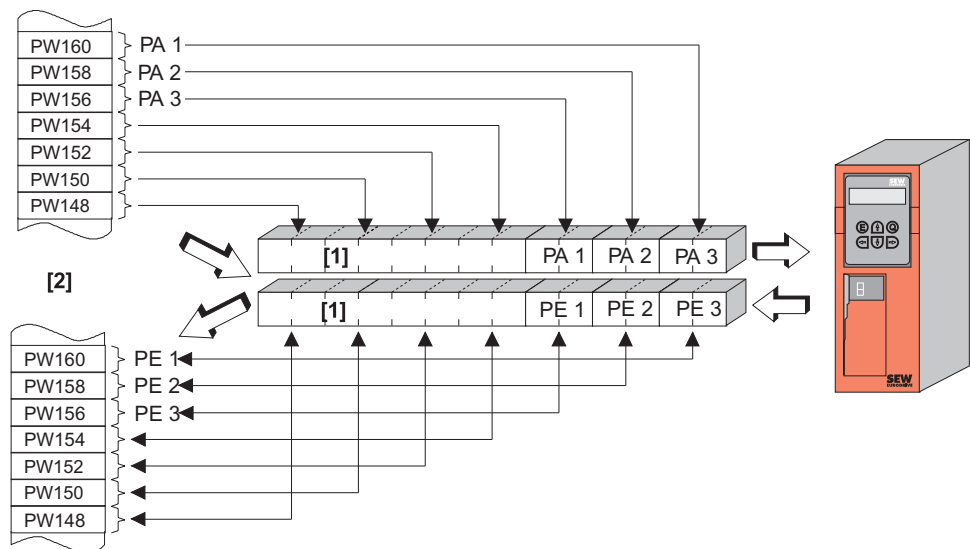

50234AXX

Figure 6: Mapping of PROFIBUS data in the PLC address range ([1] = parameter channel / [2] = PLC address range)

PO = process output data / PI = process input data

Additional information on programming and project planning can be found in the README_GSD6003.PDF file which you will receive with the GSD file.

Control example for Simatic S5

While the process input data (actual values) are read in via load commands for the Simatic S5, the process output data (setpoints) can be transmitted using the transfer commands. Based on the following figure, the example shows the syntax for processing the process input and output data of the MOVIDRIVE® drive inverter. The factory setting for the process data channel is listed in the comment section.



Detailed information on the control via process data channel, especially on the coding of the control and status word, can be found in the manual of the fieldbus unit profile.

STEP5 programming example



For this example, MOVIDRIVE® is configured with process data configuration “3 PD” to the input addresses PW156... and output addresses PW156....

In this example, the consistent access is carried out in the order “last byte first.”

Caution!

Maintenance of data integrity for Simatic S5 is primarily determined by the CPU type. You will find information on the correct programming with data integrity in the manuals for the CPU or the DP master circuit board of Simatic S5.

```
//Read in actual values consistently
L PW 160 //Load PI1 (status word 1)
L PW 158 //Load PI2 (actual speed value)
L PW 156 //Load PI3 (no function)

//Output setpoints consistently
L KH 0
T PW 160 //Write 0hex to P03 (although it is without function)
L KF +1500
T PW 158 //Write 1500dec to P02 (speed setpoint = 300 1/min)
L KW#16#0006
T PW 156 //Write 6hex to P01 (control word = enable)
```

Control example for Simatic S7

Control of the drive inverter via Simatic S7 takes place depending on the selected process data configuration, either directly via load and transfer commands or via special system functions *SFC 14 DPRD_DAT* and *SFC15 DPWR_DAT*.

Data lengths with 3 bytes or more than 4 bytes must always be transmitted via system functions SFC14 and SFC15 for S7. The following table applies:

Process data configuration	STEP7 access via
1 PD	Load/transfer command
2 PD	Load/transfer command
3 PD	SFC14/15 system functions (6 bytes long)
6 PD	SFC14/15 system functions (12 bytes long)
10 PD	SFC14/15 system functions (20 bytes long)
Param +1 PD	Parameter channel: SFC14/15 system functions (8 bytes long) Process data: load/transfer command
Param +2 PD	Parameter channel: SFC14/15 system functions (8 bytes long) Process data: load/transfer command
Param +3 PD	Parameter channel: SFC14/15 system functions (8 bytes long) Process data: SFC14/15 system functions (6 bytes long)
Param +6 PD	Parameter channel: SFC14/15 system functions (8 bytes long) Process data: SFC14/15 system functions (12 bytes long)
Param + 10 PD	Parameter channel: SFC14/15 system functions (8 bytes long) Process data: SFC14/15 system functions (20 bytes long)



STEP7 programming example

For this example, MOVIDRIVE® is configured with process data configuration “3 PD” to the input addresses PIW576... and output addresses POW576....

A DB3 data block with approx. 50 data words is created.

The process input data are copied in the DB3 data block, data word 0, 2 and 4 by calling up SFC14. After processing the control program, SFC15 is called up to copy the process output data of data word 20, 22 and 24 to the output address POW 576....

Observe the length information in bytes for the RECORD parameter. It must be identical with the configured length.

Additional information on the system functions can be found in the online help to STEP7.

```
//Beginning of the cyclical program processing in OB1
BEGIN
NETWORK
TITLE =Copy PI data from inverter in DB3, word 0/2/4
CALL SFC 14 (DPRD_DAT) //Read DP slave record
LADDR := W#16#240 //Input address 576
RET_VAL:= MW 30 //Result in flag word 30
RECORD := P#DB3.DBX 0.0 BYTE 6 //Pointer

NETWORK
TITLE =PLC program with drive application
// PLC program uses process data in DB3 for
// drive control

L DB3.DBW 0 //Load PI1 (status word 1)
L DB3.DBW 2 //Load PI2 (actual speed value)
L DB3.DBW 4 //Load PI3 (no function)

L W#16#0006
T DB3.DBW 20//Write 6hex to PO1 (control word = enable)
L 1500
T DB3.DBW 22//Write 1500dec to PO2 (speed setpoint = 300 1/min)
L W#16#0000
T DB3.DBW 24//Write 0hex to PO3 (no function)

//End of the cyclical program processing in OB1
NETWORK
TITLE =Copy PO data from DB3, word 20/22/24 to inverter
CALL SFC 15 (DPWR_DAT) //Write DP slave record
LADDR := W#16#240 //Output address 576 = 240hex
RECORD := P#DB3.DBX 20.0 BYTE 6 //Pointer to DB/DW
RET_VAL:= MW 32 //Result in flag word 32
```

5.2 PROFIBUS DP timeout

The response monitoring time in the MOVIDRIVE® elapses (if configured in the DP master) in case the data transfer via PROFIBUS DP is disrupted or interrupted. The “BUS-FAULT” LED lights up or flashes to signal that no new user data are being received. At the same time, MOVIDRIVE® executes the fault response selected with *P831 Fieldbus Timeout Response*.

P819 Fieldbus Timeout shows the response monitoring time specified by the DP master in the initial start of the PROFIBUS DP. A change of this timeout setting can only be carried out via DP master. While changes via keypad or MOVITOLS® are displayed, they are not effective and are overwritten during the next DP initial start.



5.3 Fieldbus timeout response

The parameter of the fault response triggered via fieldbus timeout monitoring is set with P831. The parameter setting performed here must be conclusive to the setting in the master system (S7: response monitoring).

5.4 Setting parameters via PROFIBUS DP

For PROFIBUS DP, access to the drive parameters is carried out via MOVILINK[®] parameter channel which offers additional parameter services next to the traditional READ and WRITE services.

Structure of the parameter channel

For PROFIBUS DP, access to the drive parameters of the inverter is carried out via “Parameter process data object” (PPO). This PPO is transmitted cyclically and contains the process data channel as well as a parameter channel that can be used to exchange acyclical parameter values.

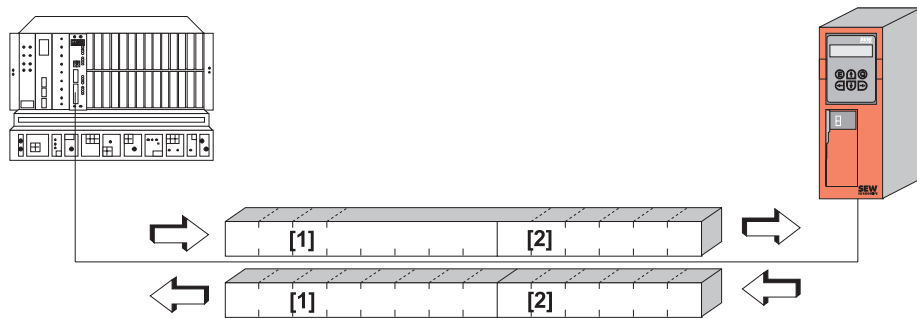

01065CXX

Figure 7: Communication via PROFIBUS DP with parameter channel [1] and process data channel [2]

The following table shows the structure of the parameter channel. In principle, it consists of a management byte, an index word, a reserved byte and four data bytes.

Table 9: Structure of the parameter channel

Byte 0	Byte 1	Byte 2	Byte 3	Byte 4	Byte 5	Byte 6	Byte 7
Manage	Reserved	Index High	Index Low	MSB data	Data	Data	LSB data
Parameter index				4-byte data			



Management of the parameter channel

The entire parameter adjustment procedure is coordinated with byte 0: management. This byte makes important parameters available, such as service identifier, data length, version and status of the executed service. The following table shows that bits 0, 1, 2 and 3 contain the service identifier, thereby defining which service is executed. Bits 4 and 5 specify the data length in byte for the write service which generally should be set to 4 bytes for SEW drive inverters.

Table 10: Structure of the management byte

7 / MSB	6	5	4	3	2	1	0 / LSB
				Service identifier 0000 = No service 0001 = Read parameter 0010 = Write parameter 0011 = Write parameter volatile 0100 = Read minimum 0101 = Read maximum 0110 = Read default 0111 = Read scale 1000 = Read attribute			
		Data length 00 = 1 byte 01 = 2 bytes 10 = 3 bytes 11 = 4 bytes (must be set!)					
		Handshake bit must be changed with each new task for cyclical transfer					
		Status bit 0 = no fault in service execution 1 = fault in service execution					

Bit 6 serves as handshake between controller and drive inverter. It triggers the execution of the transferred service in the drive inverter. Since the parameter channel is transferred in each cycle together with the process data for PROFIBUS DP, the execution of the service in the drive inverter must be edge-triggered using handshake bit 6. The value of this bit is therefore toggled each time a new service is to be executed. The drive inverter uses the handshake bit to signal whether the service has been executed or not. The service is executed as soon as the controller notices that the received and transmitted handshake bits are identical. Status bit 7 indicates whether the service was executed properly or whether it produced an error.

Index addressing

Byte 2: Index High and byte 3: Index Low are used to identify the parameter to be read or written via the fieldbus system. The parameters of a drive inverter are addressed with a uniform index independent of the connected fieldbus system. Byte 1 should be considered reserved and must generally be set to 0x00.



Data area

As shown in the following table, the data are contained in bytes 4 through 7 of the parameter channel. This allows a maximum of 4 byte data to be transmitted for each service. The data are generally entered flush right, i.e. byte 7 contains the least significant data byte (LSB data), byte 4 correspondingly the most significant data byte (MSB data).

Table 11: Definition of the data area in the parameter channel

Byte 0	Byte 1	Byte 2	Byte 3	Byte 4	Byte 5	Byte 6	Byte 7
Manage	Reserved	Index High	Index Low	MSB data	Data	Data	LSB data
				High byte 1	Low byte 1	High byte 2	Low byte 2
				High word		Low word	
				Double word			

Incorrect service execution

Incorrect service execution is signaled by setting the status bit in the management byte. If the received handshake bit is identical to the transmitted handshake bit, the drive inverter has executed the service. If the status bit indicates an error, the error code is entered in the data area of the parameter message. Bytes 4 through 7 provide the return code in a structured format (see section Return Codes).

Table 12: Structure of the parameter channel in the event of incorrect service execution

Byte 0	Byte 1	Byte 2	Byte 3	Byte 4	Byte 5	Byte 6	Byte 7
Manage	Reserved	Index High	Index Low	Error Class	Error Code	Add. code high	Add. code low
Status bit = 1: Incorrect service execution							

Reading a parameter via PROFIBUS DP (Read)

The handshake bit may be changed only after the complete parameter channel was prepared according to the service because of the cyclical transfer of the parameter channel to execute a READ service via parameter channel. The following sequence should be observed for reading a parameter:

1. Enter the index of the parameter to be read in byte 2 (Index High) and byte 3 (Index Low).
2. Enter the service identifier for the Read service in the management byte (Byte 0).
3. Transfer the Read service to the inverter by changing the handshake bit.

Since this is a read service, the transmitted data bytes (bytes 4 through 7) and the data length (in the management byte) are ignored and do not have to be set.



The inverter processes only the Read service and returns the service confirmation with a change of the handshake bit.

Table 13: READ service coding in the management byte

7 / MSB	6	5	4	3	2	1	0 / LSB
0	0/1	X	X	0	0	0	1
				Service identifier 0001 = Read parameter			
				Data length not relevant for Read service			
				Handshake bit must be changed with each new task for cyclical transfer			
Status bit 0 = no fault in service execution 1 = fault in service execution							

X = not relevant
0/1 = bit value is changed

The figure above shows the coding of a READ service in the management byte. The data length is not relevant, only the service identifier for the READ service must be entered. This service is then activated in the drive inverter with a change of the handshake bit. For example, the Read service could be activated with the management byte coding 01hex or 41hex.

Writing a parameter via PROFIBUS DP (Write)

The handshake bit may be changed only after the complete parameter channel was prepared according to the service because of the cyclical transfer of the parameter channel to execute a WRITE service via parameter channel. The following sequence should be observed for writing a parameter:

1. Enter the index of the parameter to be written in byte 2 (Index High) and byte 3 (Index Low).
2. Enter the data to be written in bytes 4 through 7.
3. Enter the service identifier and the data length for the Write service in the management byte (Byte 0).
4. Transfer the Write service to the inverter by changing the handshake bit.

The inverter processes only the Write service and returns the service confirmation with a change of the handshake bit.

The following table shows the coding of a WRITE service in the management byte. The data length is 4 bytes for all parameters of the SEW drive inverters. This service is then transferred to the drive inverter with a change of the handshake bit. Thus, a Write service on SEW drive inverters generally features the management byte coding 32hex or 72hex.



Table 14: WRITE service coding in the management byte

7 / MSB	6	5	4	3	2	1	0 / LSB
0	0/1	1	1	0	0	1	0
				Service identifier 0010 = Write parameter			
				Data length 11 = 4 bytes			
				Handshake bit must be changed with each new task for cyclical transfer			
Status bit 0 = no fault in service execution 1 = fault in service execution							

0/1 = bit value is changed

Parameter setting procedure with PROFIBUS DP

Using the WRITE service, the following figure is used to show a parameter setting procedure between controller and drive inverter via PROFIBUS DP. The following figure represents only the management byte of the parameter channel to simplify the procedure.

While the controller prepares the parameter channel for the Write service, the parameter channel is only received and returned by the drive inverter. The service is only activated once the handshake bit has been changed, in this example changing from 0 to 1. The drive inverter now interprets the parameter channel and processes the Write service, but continues to answer all messages with handshake bit = 0. The confirmation for the executed service is carried out with a change of the handshake bit in the response message of the drive inverter. The controller now recognizes that the received handshake bit is once again identical with the transmitted one and it can prepare a new parameter setting.



Table 15: Parameter setting procedure with PROFIBUS DP

Controller	PROFIBUS DP	Drive inverter (slave)
	-- 00110010XXX... →	Parameter channel is received, but not evaluated
	← 00110010XXX... --	
Parameter channel is prepared for Write service		
Handshake bit is changed and service is transferred to drive inverter	-- 01110010XXX... →	
	← 00110010XXX... --	
	-- 01110010XXX... →	
	← 00110010XXX... --	Write service executed, handshake bit is changed
Service confirmation received since send and receive handshake bit are identical again	← 01110010XXX... --	
	-- 01110010XXX... →	Parameter channel is received, but not evaluated

Parameter data Format

The parameter setting via fieldbus interface uses the same parameter coding as via serial RS-485 interfaces or system bus.

The data formats and value ranges for the individual parameters can be found in the SEW documentation MOVIDRIVE® Parameter Listing.



6 Parameter Setting Return Codes

6.1 Elements

If parameters are set incorrectly, the drive inverter returns various return codes to the parameter setting master providing detailed information on the cause of the error. In general, these return codes feature a structured design. The following elements can be distinguished:

- Error Class
- Error Code
- Additional Code

A detailed description of these return codes can be found in the manual accompanying the fieldbus communications profile. They are not listed separately in this documentation. However, the following special cases may occur in connection with PROFIBUS:

Error class

The error class component provides a more exact classification of the error type. MOVIDRIVE® supports the following error classes defined in accordance with EN 50170(V2):

Table 16: Error classes in accordance with EN 50170 (Error Class)

Class (hex)	Designation	Meaning
1	vfd state	Status error of the virtual field device
2	application reference	Error in application program
3	definition	Definition error
4	resource	Resource error
5	service	Error at service execution
6	access	Access error
7	ov	Error in object list
8	other	Other error (see Additional Code)

The error class is generated by the communications software of the fieldbus card in the case of a faulty communication, except for *Error Class 8 = Other Error*. Return codes that are provided by the drive inverter system fall under the category *Error Class 8 = Other Error*. A more detailed error breakdown is achieved with the Additional Code component.

Error code

The error code component allows for a more detailed breakdown of the error cause within the error class and is generated by the communications software of the fieldbus card in the case of a faulty communication. Only *Error Code = 0* (Other Error Code) is defined for *Error Class 8 = Other Error*. In this case, the detailed breakdown is achieved in the *Additional Code*.

**Additional code**

The additional code contains SEW-specific return codes for faulty parameter setting of the drive inverter. They are returned to the master under *Error Class 8 = Other Error*. The following table shows all possible codings for the Additional Code.

Table 17: List of additional codes for error class 8 = Other Error

Add.-Code high (hex)	Add.-Code low (hex)	Meaning
00	00	No error
00	10	Illegal parameter index
00	11	Function/parameter not implemented
00	12	Read access only
00	13	Parameter lock is active
00	14	Factory setting is active
00	15	Value too large for parameter
00	16	Value too small for parameter
00	17	Required option card missing for this function/parameter
00	18	Error in system software
00	19	Parameter access only via RS485 process interface to X13
00	1A	Parameter access only via RS485 diagnostics interface
00	1B	Parameter is access-protected
00	1C	Controller inhibit required
00	1D	Illegal value for parameter
00	1E	Factory setting was activated
00	1F	Parameter was not saved in EEPROM
00	20	Parameter cannot be changed with enabled output stage

6.2 Special cases

Special return codes (special cases)

Parameter setting errors that are neither recognized automatically by the application layer of the fieldbus system nor by the system software of the drive inverter are treated as special cases. This includes the following possible errors, depending on the installed fieldbus option card:

- Incorrect coding of a service via parameter channel
- Incorrect length information of a service via parameter channel
- Internal communications error



Incorrect service coding in parameter channel

While setting the parameters via the parameter channel, an incorrect coding for the management and reserved bytes were entered. The following table shows the return code for this special case.

Table 18: Return code for incorrect coding of bytes 0 and 1 in the parameter channel

	Code (dec)	Meaning
Error class:	5	Service
Error code:	5	Illegal parameter
Add. code high:	0	-
Add. code low:	0	-

Error correction:

Check bits 0 and 1 in the parameter channel.

Incorrect length information in parameter channel

While setting the parameters via the parameter channel, a data length other than 4 data bytes was entered in the Read or Write service. The following table shows the return code.

Table 19: Return code for incorrect length information in the parameter channel (length \neq 4)

	Code (dec)	Meaning
Error class:	6	Access
Error code:	8	Type conflict
Add. code high:	0	-
Add. code low:	0	-

Error correction:

Check bits 4 and 5 for the data length in the management byte of the parameter channel. Both bits must show the value 1.



Internal communications error

The return code listed in the following table is returned if an internal communications error occurs. The parameter service transmitted via the fieldbus may not have been executed and should be repeated. If this error occurs again, the drive inverter must be completely switched off and back on again to perform a new initialization.

Table 20: Return code for internal communications error

	Code (dec)	Meaning
Error class:	6	Access
Error code:	2	Hardware fault
Add. code high:	0	-
Add. code low:	0	-

Error correction:

Repeat the read or write service. If this error occurs again, briefly disconnect the drive inverter from the power supply and switch it on again. If this error occurs permanently, consult the SEW service.



7 Troubleshooting

7.1 Diagnostics procedures

The diagnostics procedures described below illustrate the procedure for error analysis of the most frequently occurring problems:

- The inverter does not function at the PROFIBUS DP.
- The inverter cannot be controlled with the DP master.

Additional information specifically pertaining to the parameter setting of the inverter for various fieldbus applications can be found in the *Fieldbus Unit Profile and MOVIDRIVE® Parameter Listing* manual. In addition, please read the current information on the GSD disks.



Diagnostic problem 1: The inverter does not function at the PROFIBUS.

Initial state:

- Inverter physically connected to PROFIBUS
- Inverter configured in DP master and bus communications active

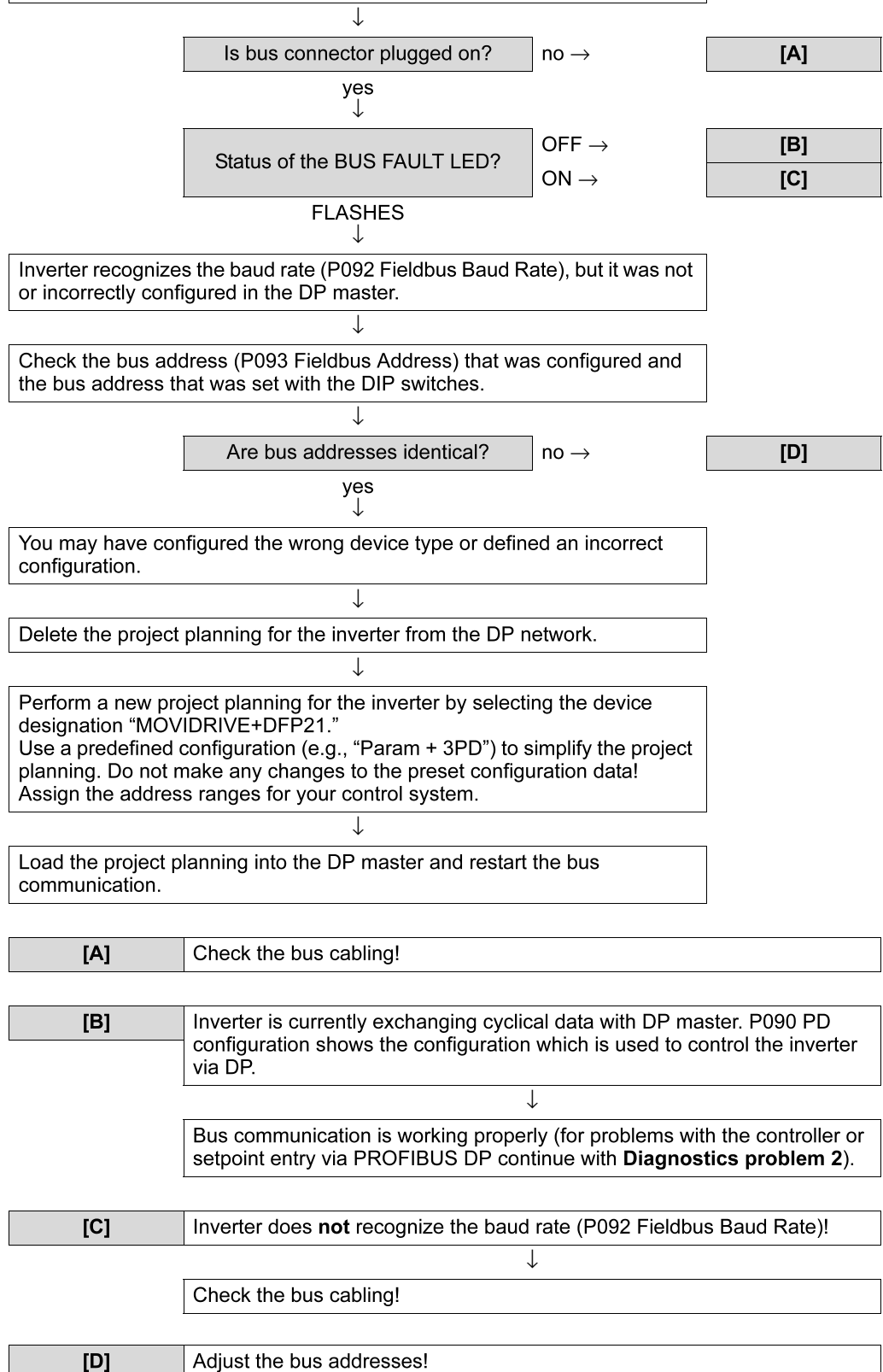

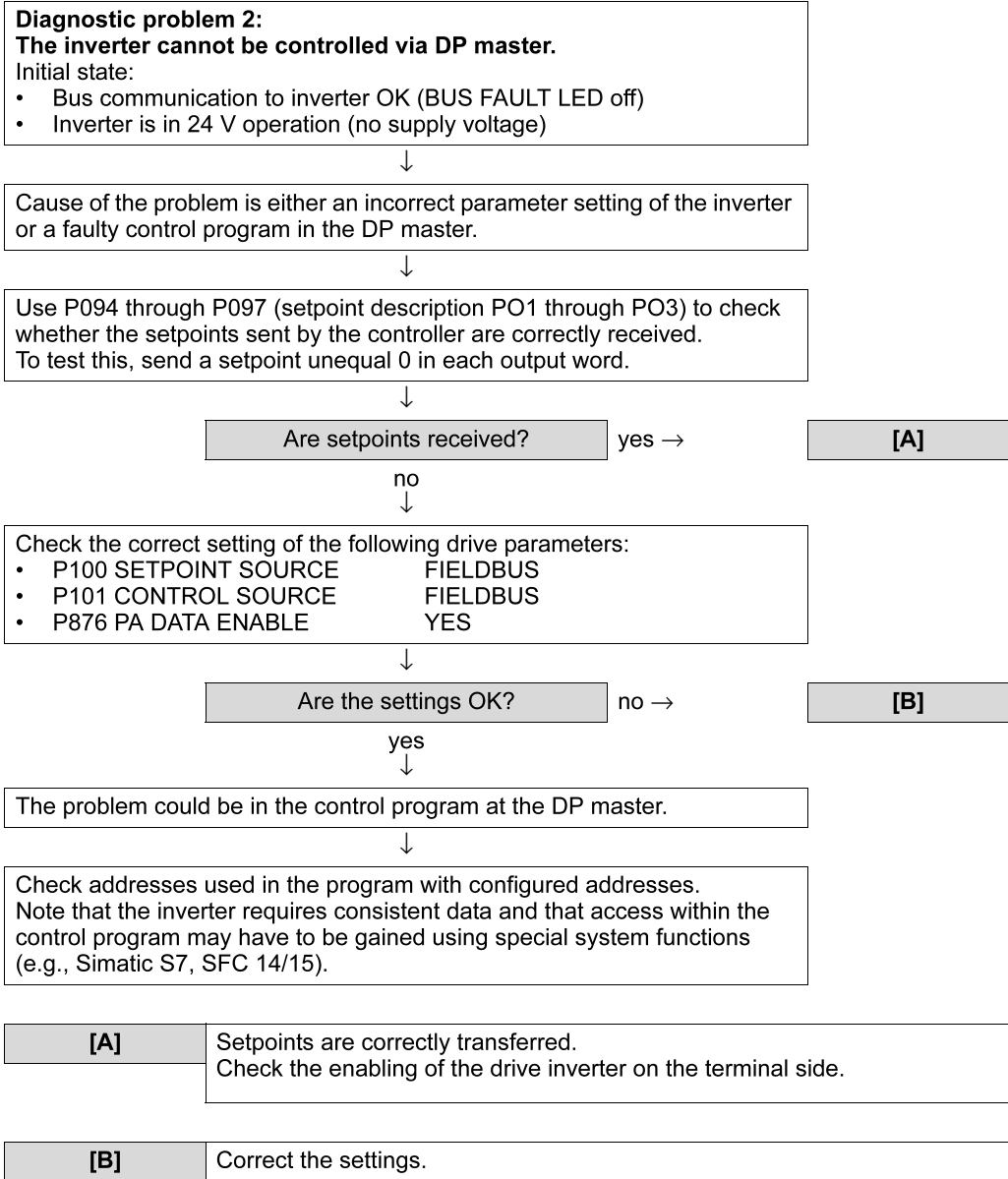

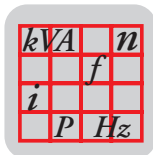

8 Technical Data

Part no. for PROFIBUS interface	• 823 618 6
Profibus protocol variants	• PROFIBUS DP in accordance with EN 50170 V2 / DIN E 19245 T3
Automatic baud rate detection	• 9.6 kBaud to 12 MBaud
Connection technology	• via 9-pole sub-D socket • pin assignment to EN 50170 (V2)
Bus termination	• not integrated, via PROFIBUS connector
Station address	• 0-125 adjustable via DIP switches
Name of GSD file	• SEW_6003.GSD
DP ident number	• 6003hex = 24579dec
Application-specific parameter setting data (Set-Prm-UserData)	• 9 bytes long • hex parameter setting 00,00,00,06,81,00,00,01, 01 = DP diagnostics alarm = OFF • hex parameter setting 00,00,00,06,81,00,00,01, 00 = DP diagnostics alarm = ON
DP configurations for DDLM_Chk_Cfg	• F0hex = 1 process data word (1 I/O word) • F1hex = 2 process data words (2 I/O words) • F2hex = 3 process data words (3 I/O words) • 0hex, F5hex = 6 process data words (6 I/O words) • 0hex, F9hex = 10 process data words (10 I/O words) • F3hex, F0hex = parameter channel +1 process data word (5 I/O words) • F3hex, F1hex = parameter channel +2 process data words (6 I/O words) • F3hex, F2hex = parameter channel +3 process data words (7 I/O words) • F3hex, F5hex = parameter channel +6 process data words (10 I/O words) • F3hex, F9hex = parameter channel +10 process data words (14 I/O words)
Diagnostics data	• Max. 8 bytes • standard diagnostics 6 bytes
Tools for startup	• MOVITOOLS® program • DBG11 keypad



9 Index

A

Additional Code 32

B

Baud rate 10, 38
Bus cable 10
BUS FAULT 12
Bus termination 38

C

Communications error, internal 34
Components 9
Configuration 5
Connection technology 38
Control 22
Control example 23

D

Data format, parameter 30
Device types 8
DFP11A / DFP21A 6
Diagnosis data 38
Diagnostics 5
Display elements 12
DP configuration 14
DP configuration, universal 15
DP configurations 38
DP ident number 38

E

Error class 31
Error Code 31

F

Fault diagnosis 35
Faulty service execution 27
Fieldbus monitor 5
Front view 9

G

GSD file 38

I

Ident number 38
Index addressing 26
Internal communications error 34

L

LEDs 12
Length information 33

M

Management, parameter channel 26
Monitoring functions 5

P

Parameter channel 25
Parameter channel data area 27
Parameter channel, management 26
Parameter channel, structure 25
Parameter data format 30
Parameterization data 38
Parameterization procedure 30
Parameters, reading 27
Parameters, writing 28
Part number 38
Procedure, parameterization 30
PROFIBUS DP timeout 24
Protocol variants 38

R

READ 27
Reading parameters 27
Return codes 31
Routing of bus cable 10
RUN 12

S

Service coding 33
Service execution, faulty 27
Setting parameters via PROFIBUS DP 25
Shielding of bus cable 10
Simatic S5 22
Simatic S5 control example 22
Simatic S7 23
Startup 19
Station address 38
STEP5 23
STEP5 Programming Example 23
STEP7 24
STEP7 programming example 24
Structure, parameter channel 25
Supported device types 8

T

Technical Data 38
Timeout 24

U

Universal DP configuration 15

W

WRITE 28
Writing parameters 28

SEW-EURODRIVE GmbH & Co · P.O. Box 3023 · D-76642 Bruchsal/Germany · Phone +49-7251-75-0
Fax +49-7251-75-1970 · <http://www.sew-eurodrive.com> · sew@sew-eurodrive.com

SEW
EURODRIVE

