

MITSUBISHI

QnA SERIES

For QnA Ethernet Interface Module

User's Manual

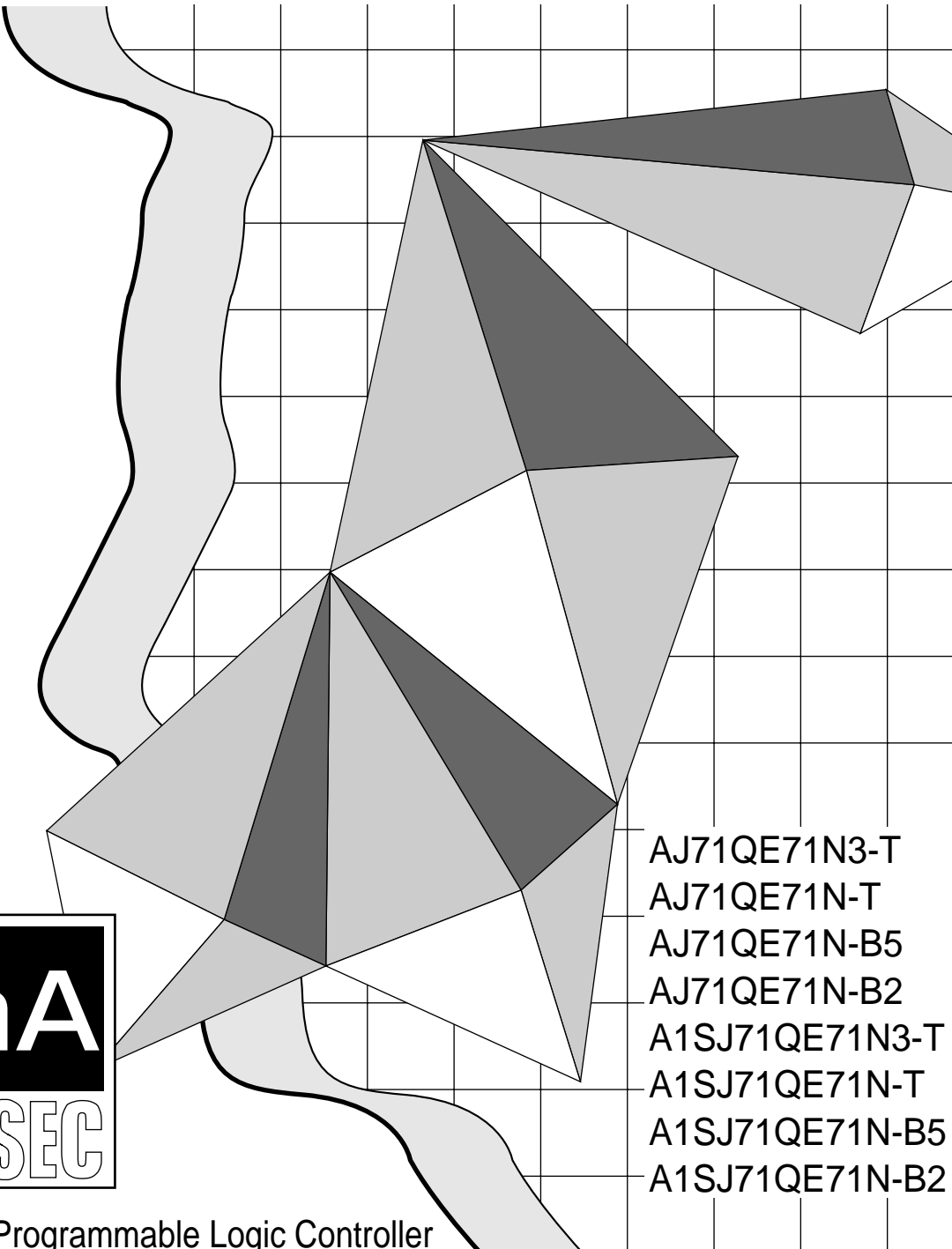

Mitsubishi Programmable Logic Controller

An abstract graphic composed of several overlapping, shaded geometric shapes (triangles and polygons) on a grid background. The shapes are rendered in various shades of gray, creating a sense of depth and movement. The overall composition is dynamic and modern.

AJ71QE71N3-T
AJ71QE71N-T
AJ71QE71N-B5
AJ71QE71N-B2
A1SJ71QE71N3-T
A1SJ71QE71N-T
A1SJ71QE71N-B5
A1SJ71QE71N-B2

● SAFETY PRECAUTIONS ●

(Read these precautions before using.)

When using Mitsubishi equipment, thoroughly read this manual and the associated manuals introduced in this manual. Also pay careful attention to safety and handle the module properly.

These precautions apply only to Mitsubishi equipment. Refer to the user's manual of the CPU module to use for a description of the PLC system safety precautions.

These ● SAFETY PRECAUTIONS ● classify the safety precautions into two categories: "DANGER" and "CAUTION".



DANGER

Procedures which may lead to a dangerous condition and cause death or serious injury if not carried out properly.



CAUTION

Procedures which may lead to a dangerous condition and cause superficial to medium injury, or physical damage only, if not carried out properly.

Depending on circumstances, procedures indicated by  **CAUTION** may also be linked to serious results. In any case, it is important to follow the directions for usage.

Store this manual in a safe place so that you can take it out and read it whenever necessary. Always forward it to the end user.

[DESIGN PRECAUTIONS]



DANGER

- When controlling (changing data, program or operation status (remote RUN/STOP) in particular) a PLC while it is running via a device such as a personal computer connected to the special function module, configure an interlock circuit in the sequence program so that the safety of the overall system is always maintained.

Especially, when performing the above control for a remote PLC from an external device, troubles occurring on the PLC side due to data communication error may not be handled immediately.

Determine error handling methods between the external device and the PLC CPU for when data communication errors occur, in addition to configuring an interlock circuit in the sequence program.



CAUTION

- Do not bundle the control wires and the communication cables with the main circuit and the power wires, and do not install them close to each other.

They should be installed 100mm (3.9 inch) or more from each other.

Not doing so could result in noise that would cause erroneous operation.

[INSTALLATION PRECAUTIONS]

CAUTION

- Use the PLC in an environment that meets the general specifications contained in this manual. Using this PLC in an environment outside the range of the general specifications could result in electric shock, fire, malfunction, and damage to or deterioration of the product.
- Make sure to switch off all phases of the external power supply used by the system before installing or placing wiring. Not doing so could result in electric shock or damage to the product.
- Shut off all phases of the external power supply in the system before mounting or dismounting the module. Otherwise, it will cause failure or malfunction of the module.
- Insert the fixing latch on the bottom of the module into the fixing hole in the base unit and install the module using the hole point as a fulcrum.
(The Q2AS series module shall be fastened to the base unit by screws using the specified torque.)
If the module is not properly installed, it may result in malfunctions, breakdowns, or the module may fall off.
- Tighten the screw within the range of specified torque. If the screws are loose, it may result in fallout, short circuits, or malfunctions.
Tightening the screws too far may cause damage to the screw and/or the module, resulting in fallout, short circuits, or malfunctions.
- Do not directly touch the module's conductive parts or electronic components. Doing so could cause malfunction or trouble in the module.

[WIRING PRECAUTIONS]

CAUTION

- Do not connect the AUI cables when the module installation station's power is turned on.
- The communication cables and power cables connected to the module must always be set in ducts or secured using clamps.
If the cable is not placed in a duct or not secured with clamps, it may be loosened, relocated or pulled unintentionally, causing malfunctions or damage to the module and cable.
- Perform correct pressure-displacement, crimp-contact or soldering for wire connections using the tools specified by the manufactures. Attach connectors to the module securely.
- Tighten the terminal screws within the range of specified torque.
If the terminal screws are loose, it may result in short circuits or malfunctions.
Tightening the screws too far may cause damage to the screw and/or the module, resulting in fallout, short circuits, or malfunctions.
- When removing communication cables or power cables connected to the module, do not pull directly on the cable.
For cables with connectors, remove them by holding the connector that connects to the module. For cables without connectors, remove them after loosening the screws in the connection area. If the cable is pulled while it is connected to the module, it may cause a malfunction or damage to the module and cable.
- Be sure there are no foreign substances such as sawdust or wiring debris inside the module. Such debris could cause fires, damage, or malfunction.

[STARTING AND MAINTENANCE PRECAUTIONS]

DANGER

- Do not touch the connector while the power is on. Doing so could cause malfunction.
- Make sure to switch off all phases of the external power supply used by the system before cleaning or re-tightening screws. Otherwise, it will cause failure or malfunctions of the module. If the screws are loose, it may result in fallout, short circuits, or malfunctions. Tightening the screws too far may cause damage to the screw and/or the module, resulting in fallout, short circuits, or malfunctions.

CAUTION

- Do not disassemble or modify the modules. Doing so could cause trouble, malfunction, injury, or fire.
- Make sure to switch off all phases of the external power supply used by the system before mounting or removing the module. Otherwise, it will cause failure or malfunction of the module.
- Always make sure to touch the grounded metal to discharge the electricity charged in the body, etc., before touching the module.
Failure to do so may cause a failure or malfunctions of the module.

[OPERATING PRECAUTIONS]

DANGER

- Do not write data in the "system area" in the buffer memory of the special function module. Also, of the output signals directed to the special function module from the PLC CPU, do not output (switch ON) the signals that are "use-prohibited."
If data is written to the "system area" or output is performed with respect to a "use-prohibited" signal, it may result in the malfunction of the PLC system.

CAUTION

- Before performing the control of the PLC in operation (especially changing data, program, and operation status (remote RUN/STOP)) by connecting a personal computer, etc. to the special function module, read the manual carefully and confirm if the overall safety is maintained.
Failure to perform correct operations to change data, program, or operation status may result in system malfunctioning, machine damage, or an accident.
- Remote RUN/STOP for the PLC CPU of the main module connection station (local station) is recommended after carefully reading the manual and being conducted under the following conditions.
 - (1) Start the main module using the automatic start mode.
 - (2) Control remote RUN/STOP using the main module automatic open UDP port.
 - (3) A data exchange function is used while the PLC CPU is stopped.
If this cannot be done, use the TCP/UDP port that the user uses to conduct open processing to conduct remote RUN/STOP. Conducting a remote stop turns the output signal from the PLC CPU to the main module off, so the communication line is disconnected (close processing). In this case, thereafter all data exchange cannot be done including PLC CPU remote RUN/STOP from the remote node.

[OPERATING PRECAUTIONS]

CAUTION

- When using the module while values, such as buffer memory set values, are registered in the EEPROM, do not turn off the power supply for the module loading station nor reset the PLC CPU. If the power supply for the module loading station is turned off or the PLC CPU is reset while any values are registered, the data contents in the EEPROM become inconsistent and as a result the values must be set again in the buffer memory, etc. and reregistered to the EEPROM. Also this may cause failure and malfunctions of the module.

[DISPOSAL PRECAUTIONS]

CAUTION

- When disposing of this product, treat it as industrial waste.

REVISIONS

* The manual number is given on the bottom left of the back cover.

Print Date	*Manual Number	Revision								
Mar., 2002	SH(NA)-080146-A	First edition								
May, 2003	SH(NA)-080146-B	<p>Additional model AJ71QE71N-T, AJ71QE71N-B5, A1SJ71QE71N-T, A1SJ71QE71N-B5</p> <p>Deleted model AJ71QE71N-B5T, A1SJ71QE71N-B5T</p> <p>Correction SAFETY PRECAUTIONS, About This Manual, About the Generic Terms and Abbreviations, Product Configuration, Section 1.1 (2), 1.3, Section 2.1, 2.2, 2.3, 2.5, Section 3.1, 3.2, 3.7.2, Section 4.2, 4.4, 4.5.1, 4.7, 4.8, 4.9, Section 5.2.2, 5.5.3, 5.6.2, Section 6.3.3, Section 7.4.3, Section 9.2.1*7, Section 10.1, 10.2.1, 10.2.10Point, 10.4Point, Section 13.6.4, Section 14.4.1, 14.4.2, 14.4.3, Section 17.1.3, Appendix 1, Appendix 6, Appendix 7.2, Appendix 9, Appendix 10</p> <p>Addition Section 17.1.3 (error code COB2H)</p> <p>Term change</p> <table border="1"> <thead> <tr> <th>Before change</th> <th>After change</th> </tr> </thead> <tbody> <tr> <td>MELSECNET/10 routing information parameter</td> <td>Station No. <-> IP information parameter</td> </tr> <tr> <td>Routing information parameter</td> <td>Router relay parameter</td> </tr> </tbody> </table>	Before change	After change	MELSECNET/10 routing information parameter	Station No. <-> IP information parameter	Routing information parameter	Router relay parameter		
Before change	After change									
MELSECNET/10 routing information parameter	Station No. <-> IP information parameter									
Routing information parameter	Router relay parameter									
Dec., 2004	SH(NA)-080146-C	<p>Additional model AJ71QE71N3-T, A1SJ71QE71N3-T</p> <p>Correction SAFETY PRECAUTIONS, About the Generic Terms and Abbreviations, Product Configuration, Section 2.3 (3), 2.5.3, Section 3.2, 3.7.2, Section 4.2, 4.3.2, 4.7.1(3), 4.7.4, Section 5.2.2, 5.5.3, 5.5.5, 5.6.2, 5.7, Section 7.3.3Remark, Section 10.1.2, Chapter11, Chapter12, Section 14.4, Section 17.1.3, Appendix 1, Appendix 3, Appendix 6, Appendix 7, Appendix 9</p> <p>Term change</p> <table border="1"> <thead> <tr> <th>Before change</th> <th>After change</th> </tr> </thead> <tbody> <tr> <td>net ID, net address</td> <td>network address</td> </tr> <tr> <td>subnet ID</td> <td>subnet address</td> </tr> <tr> <td>host ID</td> <td>host address</td> </tr> </tbody> </table>	Before change	After change	net ID, net address	network address	subnet ID	subnet address	host ID	host address
Before change	After change									
net ID, net address	network address									
subnet ID	subnet address									
host ID	host address									
Jun., 2006	SH(NA)-080146-D	<p>Correction Compliance with the EMC and Low Voltage Directives, Section 5.5.3, Appendix 3</p>								

Japanese Manual Version SH-080145-E

This manual does not imply guarantee or implementation right for industrial ownership or implementation of other rights. Mitsubishi Electric Corporation is not responsible for industrial ownership problems caused by use of the contents of this manual.

INTRODUCTION

Thank you for purchasing the Mitsubishi programmable controller MELSEC-QnA Series.

Before using your MELSEC-QnA Series, please read this manual thoroughly to gain an understanding of the functions and performances of the QnA Series PLC so that the equipment is used to its optimum.

OUTLINE OF CONTENTS

(COMMON SECTION)

1. GENERAL DESCRIPTION	1- 1 to 1-15
2. SYSTEM CONFIGURATION	2- 1 to 2-13
3. SPECIFICATIONS	3- 1 to 3-26
4. SETTINGS AND PROCEDURES UP TO OPERATION	4- 1 to 4-30
5. PROCEDURES FOR EXCHANGING WITH REMOTE NODES	5- 1 to 5-64

(FIXED BUFFER EXCHANGE SECTION)

6. FIXED BUFFER EXCHANGE WITH PROCEDURE	6- 1 to 6-14
7. FIXED BUFFER EXCHANGE WITHOUT PROCEDURE	7- 1 to 7-16

(RANDOM ACCESS BUFFER EXCHANGE SECTION)

8. RANDOM ACCESS BUFFER EXCHANGE	8- 1 to 8-16
--	--------------

(READING/WRITING DATA IN THE PLC CPU SECTION)

9. READING/WRITING DATA IN THE PLC CPU EXCHANGE	9- 1 to 9 - 26
10. WHEN READING/WRITING DATA IN THE PLC CPU WITH QE71 COMMANDS	10-1 to 10-167

(SPECIAL FUNCTIONS SECTION)

11. WHEN SETTING A SUBNET MASK	11- 1 to 11- 5
12. WHEN USING ROUTER RELAY FUNCTIONS	12- 1 to 12- 6
13. WHEN USING FILE TRANSFER FUNCTIONS (FTP SERVER)	13- 1 to 13- 30
14. WHEN THE QNACPU ACCESSES THE REMOTE STATION PLC USING THE DATA LINK COMMAND	14- 1 to 14- 49
15. WHEN EXCHANGING WITH MELSENET/10 RELAY	15- 1 to 15- 24
16. WHEN EXCHANGING WHILE PLC CPU IS STOP	16- 1 to 16- 9

(TROUBLESHOOTING SECTION)

17. TROUBLESHOOTING	17- 1 to 17-30
---------------------------	----------------

APPENDICES	APP.- 1 to APP. -44
------------------	---------------------

CONTENTS

About This Manual and Related Manuals

COMMON SECTION (CHAPTERS 1 to 5)

CHAPTER 1. GENERAL DESCRIPTION 1- 1 to 1-15

- 1.1 Software Configuration 1- 3
- 1.2 Features 1- 5
- 1.3 Comparison with Existing Modules 1-14

CHAPTER 2. SYSTEM CONFIGURATION 2- 1 to 2-13

- 2.1 Overall Configuration 2- 1
- 2.2 Supported Systems 2- 3
- 2.3 Devices Required for Network Configuration 2- 5
- 2.4 Access to the QCPU and the MELSECNET/H Remote I/O Station 2- 9
- 2.5 Precautions for Network System Configuration 2-11
 - 2.5.1 Precautions for the Selection of the QE71 2-11
 - 2.5.2 Precautions for the System Design 2-12
 - 2.5.3 Precautions for Accessing the QnACPU 2-13

CHAPTER 3. SPECIFICATIONS 3- 1 to 3-26

- 3.1 General Specifications 3- 1
- 3.2 Performance Specifications 3- 2
- 3.3 Data Codes During Exchange 3- 3
- 3.4 Functions 3- 5
 - 3.4.1 List of Functions 3- 5
 - 3.4.2 Relationship between Communication Remote Node and Added Functions for Each Communication Function 3- 7
- 3.5 Send and Receive Processing 3- 8
 - 3.5.1 Message Division and Data Length 3- 8
 - 3.5.2 Continuous Processing Over the Same Connection 3- 9
 - 3.5.3 Conditions for Issuing a Forced Disconnect 3- 9
- 3.6 I/O Signals for the PLC CPU 3-10
 - 3.6.1 List of I/O Signals 3-10
 - 3.6.2 Detailed Explanation of I/O Signals 3-11
- 3.7 Buffer Memory 3-21
 - 3.7.1 Buffer Memory Applications 3-21
 - 3.7.2 List of Buffer Memory Allocations 3-22

CHAPTER 4. SETTINGS AND PROCEDURES UP TO OPERATION 4- 1 to 4-30

- 4.1 Abbreviated Procedures Up to Operation 4- 1
- 4.2 Names of Parts 4- 2

4.3	Switch Settings	4- 3
4.3.1	Operation Mode Settings	4- 3
4.3.2	Exchange Condition Settings	4- 4
4.4	Description of Display LED's Display	4- 5
4.5	Mounting and Installation	4- 7
4.5.1	Handling Precautions	4- 7
4.5.2	Installation Environment	4- 8
4.6	Self Diagnostic Test	4- 9
4.6.1	Self-Loopback Test	4- 9
4.6.2	RAM Test	4-10
4.6.3	ROM Test	4-10
4.6.4	EEPROM Test	4-11
4.7	Connecting to the Network	4-12
4.7.1	Connection Precautions	4-12
4.7.2	Connecting to 10BASE5	4-14
4.7.3	Connecting to 10BASE2	4-15
4.7.4	Connecting to 10BASE-T	4-17
4.8	Parameter Types and Parameters that can be Set Up by GPPW	4-18
4.9	Registering Parameters (Setting Values) in the EEPROM	4-24
4.9.1	Registering Parameters in the EEPROM	4-24
4.9.2	I/O Signal and Buffer Memory for Handshaking with the PLC CPU	4-24
4.9.3	Registering, Reading, and Clearing of Parameters	4-27
4.10	Loopback Test	4-29
4.11	Maintenance and Inspection	4-29

CHAPTER 5. PROCEDURES FOR EXCHANGING WITH REMOTE NODES 5- 1 to 5-64

5.1	Overview of Exchange Procedures	5- 1
5.2	Connecting and Disconnecting Communication Lines	5- 6
5.2.1	Connecting and Disconnecting Communication Lines Using Start Up Mode	5- 6
5.2.2	Data for Initial Processing	5- 7
5.3	Initial Processing and End Processing During Request Start Up Mode	5-13
5.3.1	Initial Processing and End Processing Procedures	5-13
5.3.2	Example Program	5-14
5.3.3	Confirming the Completion of Initial Processing	5-15
5.4	Initial Processing and End Processing During Automatic Start Up Mode	5-21
5.4.1	Initial Processing and End Processing Procedures	5-21
5.4.2	Example Program	5-23
5.5	Communication Line Open and Close	5-24
5.5.1	Data for Opening	5-25
5.5.2	Communication Line Open Processing Procedure	5-32
5.5.3	Communication Line Close Processing Procedure	5-34
5.5.4	Pairing Open Communication Line Open Processing and Close Processing Procedures	5-40
5.5.5	Example Program	5-44
5.6	Exchange State Storage Area	5-50
5.6.1	Exchange State Storage Area	5-50
5.6.2	Error Log Area	5-57
5.7	Automatic Open UDP Port	5-60
5.8	Precautions for Programming	5-62

FIXED BUFFER EXCHANGE SECTION (CHAPTERS 6 AND 7)

CHAPTER 6. FIXED BUFFER EXCHANGE WITH PROCEDURE

6- 1 to 6-14

6.1	Control Format.....	6- 1
6.1.1	Transmission Control Method	6- 3
6.1.2	Reception Control Method	6- 5
6.2	Data Format.....	6- 7
6.2.1	Header	6- 7
6.2.2	Application Data.....	6- 7
6.3	Programming	6-11
6.3.1	Programming Creation Precautions.....	6-11
6.3.2	Program Creation Procedure	6-12
6.3.3	Example Fixed Buffer Exchange Program (With Procedure).....	6-13

CHAPTER 7. FIXED BUFFER EXCHANGE WITHOUT PROCEDURE

7- 1 to 7-16

7.1	Control Format.....	7- 1
7.1.1	Transmission Control Method	7- 3
7.1.2	Reception Control Method	7- 5
7.2	Data Format.....	7- 7
7.3	Simultaneous Broadcast Communication When Using UDP/IP	7- 8
7.3.1	Simultaneous Broadcast Communication Transmission	7- 8
7.3.2	Simultaneous Broadcast Communication Reception	7- 9
7.3.3	Precautions When Using Simultaneous Broadcast Communications Functions	7-11
7.4	Programming	7-12
7.4.1	Precautions When Creating Programs.....	7-12
7.4.2	Program Creation Procedures	7-14
7.4.3	Example Fixed Buffer Exchange Program (Without Procedure).....	7-15

RANDOM ACCESS BUFFER EXCHANGE SECTION (CHAPTER 8)

CHAPTER 8. RANDOM ACCESS BUFFER EXCHANGE

8- 1 to 8-16

8.1	Control Format.....	8- 1
8.1.1	Control Method When There is a Read Request from a Remote Node	8- 2
8.1.2	Control Method When There is a Write Request from a Remote Node	8- 3
8.2	Data Format.....	8- 4
8.2.1	Header	8- 4
8.2.2	Application Data.....	8- 4
8.2.3	Example Command and Response Format	8- 9
8.3	Random Access Buffer (Data Storage Area) Address	8-13
8.4	Programming	8-14
8.4.1	Program Creation Precautions	8-14
8.4.2	Program Creation Procedure	8-15

READING/WRITING DATA IN THE PLC CPU SECTION (CHAPTERS 9 AND 10)

CHAPTER 9. READING/WRITING DATA IN THE PLC CPU EXCHANGE 9- 1 to 9-26

9.1	Control Format	9- 1
9.1.1	Exchanging with the PLC CPU Installed in the QE71	9- 2
9.1.2	Exchanging with the PLC CPU in the Network System	9- 3
9.1.3	Exchanging with the PLC CPU in the Data Link System	9- 8
9.1.4	Exchanging with the PLC CPU in Mixed Systems	9-12
9.2	List of Commands	9-16
9.2.1	List of QE71 Commands and Functions	9-16
9.2.2	List of E71 Commands and Functions	9-22
9.3	PLC CPU Operation During Data Exchange	9-25
9.4	Data Exchange Precautions	9-26

CHAPTER 10. WHEN READING/WRITING DATA IN THE PLC CPU WITH QE71 COMMANDS

10- 1 to 10-167

10.1	Data Format	10- 1
10.1.1	Header	10- 1
10.1.2	Application Data	10- 1
10.1.3	Thinking Regarding Data Transmission	10- 8
10.2	Device Memory Read/Write	10-12
10.2.1	Command and Character Area Contents and Device Range	10-12
10.2.2	Bit Units Batch Read (Command : 0401)	10-20
10.2.3	Word Units Batch Read (Command : 0401)	10-22
10.2.4	Bit Units Batch Write (Command : 1401)	10-25
10.2.5	Word Units Batch Write (Command : 1401)	10-27
10.2.6	Word Units Random Read (Command : 0403)	10-30
	1 Character area data order and contents during random read	10-31
	2 Word units random read (When monitor conditions not specified)	10-41
	3 Word units random read (When monitor conditions specified)	10-43
10.2.7	Bit Units Random Write (Test) (Command : 1402)	10-45
10.2.8	Word Units Random Write (Test) (Command : 1402)	10-47
10.2.9	Device Memory Monitor	10-49
	1 Monitor procedures	10-49
	2 Monitor data registration (Command : 0801) (Monitor conditions not specified)	10-50
	3 Monitor data registration (Command : 0801) (Monitor conditions specified)	10-52
	4 Registration device memory monitor (Command : 0802)	10-54
10.2.10	Multiple Block Batch Read, Batch Write	10-56
	1 Data order in the character area during the multiple block batch read	10-56
	2 Data order in the character area during the multiple block batch write	10-58
	3 Details of the multiple block batch read and batch write	10-60
	4 Multiple block batch read (Command: 0406)	10-62
	5 Multiple block batch write (Command:1406)	10-64
10.2.11	Reading and Writing Using Device Memory Extension Specification	10-66
	1 Character area data order and contents when specifying device memory extension	10-68

	2] Device memory for which extension specification is possible and example specification	10-72
	3] Restrictions when specifying device memory extension	10-80
10.3	Buffer Memory Read/Write	10-81
10.3.1	Ethernet Interface Module Buffer Memory Read and Write	10-83
	10.3.1.1 Command and Buffer Memory	10-83
	10.3.1.2 Buffer Memory Read (Command : 0613)	10-85
	10.3.1.3 Buffer Memory Write (Command : 1613)	10-87
10.3.2	Special Function Module Buffer Memory Read and Write	10-89
	10.3.2.1 Commands and Buffer Memory	10-89
	10.3.2.2 Accessible Special Function Modules	10-94
	10.3.2.3 Special Function Module Buffer Memory Read (Command: 0601)	10-96
	10.3.2.4 Special Function Module Buffer Memory Write (Command: 1601)	10-98
10.4	PLC CPU State Control	10-100
10.4.1	Command and Control Description and Character Area Contents	10-101
10.4.2	Remote RUN (Command : 1001)	10-103
10.4.3	Remote STOP (Command : 1002)	10-104
10.4.4	Remote PAUSE (Command : 1003)	10-105
10.4.5	Remote Latch Clear (Command : 1005)	10-106
10.4.6	Remote RESET (Command : 1006)	10-107
10.5	Drive Memory Optimization	10-108
10.5.1	Command and Character Area Contents	10-109
10.5.2	Drive Memory Usage State Read (Command : 0205)	10-112
10.5.3	Drive Memory Optimization (Command : 1207)	10-113
10.6	File Control	10-114
10.6.1	Command and Character Area Contents	10-114
10.6.2	Precautions When Using File Control	10-125
10.6.3	File Control Execution Procedure	10-126
	1] File contents read procedure	10-126
	2] File new creation and data write procedure Procedure for copying existing file data to a newly created file	10-127
	3] Existing file data overwrite procedure Procedure for changing file information	10-128
	4] File delete procedure	10-129
10.6.4	Reading the File Information List	10-130
	1] Reading the file information list without titles (Command : 0201)	10-130
	2] Reading the file information list with titles (Command : 0202)	10-132
	3] Reading the file No. usage state (Command : 0204)	10-134
10.6.5	Changing File Information (Command : 1204)	10-136
	1] Changing the file creation date and time (Command : 1204, subcommand : 0000)	10-136
	2] Changing the file name, attribute, and size (Command : 1204, subcommand : 0001)	10-138
	3] Batch changing of file information (Command : 1204, subcommand : 0002)	10-140
10.6.6	Reading a File Existence (File Search) (Command : 0203)	10-142
10.6.7	Reading File Contents (Command : 0206)	10-144
10.6.8	Creating New Files (File Name Registration) (Command : 1202)	10-146
10.6.9	Writing to Files (Command : 1203)	10-148

1	Batch writing	10-148
2	Writing the same data (FILL)	10-150
10.6.10	Registering and Deleting File Lock (Command : 0808)	10-152
10.6.11	File Copy (Command : 1206)	10-154
10.6.12	Deleting Files (Command : 1205)	10-156
10.7	Registering and Reading EEPROM Parameters (Setting Values)	10-158
10.7.1	Command and Character Area Contents	10-158
10.7.2	Reading Parameters (Command : 0611)	10-160
10.7.3	Registering Parameters (Command : 1611)	10-162
10.8	Turning Off COM.ERR LED	10-164
10.8.1	Command and Character Area Contents	10-164
10.8.2	Turning Off COM.ERR LED (Command : 1617)	10-165
10.9	Loopback Test	10-166
10.9.1	Command and Character Area Contents	10-166
10.9.2	Loopback Test (Command : 0619)	10-167

SPECIAL FUNCTIONS SECTION (CHAPTERS 11 to 16)
--

CHAPTER 11. WHEN SETTING A SUBNET MASK	11- 1 to 11- 5
---	-----------------------

11.1	Subnet Mask	11- 1
11.2	Setting for the Subnet Mask	11- 3
11.3	Ethernet IP Address	11- 4

CHAPTER 12. WHEN USING ROUTER RELAY FUNCTIONS	12- 1 to 12- 6
--	-----------------------

12.1	Router Relay Functions	12- 1
12.2	Exchangeable Functions and Settable Range Using Router Relay Functions	12- 2
12.3	Summary of Router Relay Processing	12- 2
12.4	Setting for Using Router Relay Functions	12- 3

CHAPTER 13. WHEN USING FILE TRANSFER FUNCTIONS (FTP SERVER)	13- 1 to 13-30
--	-----------------------

13.1	File Transfer Functions	13- 1
13.1.1	File Transfer Functions	13- 1
13.1.2	FTP Server Support Functions of QE71	13- 3
13.2	File Transferable Range	13- 5
13.3	Setting for File Transfer	13- 6
13.4	File Transfer Procedure	13- 8
13.4.1	Procedures and Required Processes at the QE71 (FTP Server)	13- 8
13.4.2	Procedures and Required Processes at the Remote Node (FTP Client)	13- 9
13.5	Precautions When Using the File Transfer Functions	13-12
13.6	FTP Commands	13-15
13.6.1	File Specification Method	13-15
13.6.2	QnACPU User File List	13-17
13.6.3	Response Code	13-18
13.6.4	FTP Operation Command	13-19
1	FTP server support commands	13-20
binary	(Notifies that the transfer is performed without converting the file)	13-20

bye	(Shuts down the FTP server connection, and ends FTP)	13-20
close	(Shuts down the FTP server connection)	13-20
delete	(Deletes the file)	13-20
dir	(Displays the file names, created dates, and sizes of the files)	13-20
get	(Reads the file)	13-21
ls	(Display the file names)	13-21
mdelete	(Deletes the file)	13-21
mdir	(Stores the file information to the FTP client-side)	13-22
mget	(Reads a file)	13-22
mls	(Stores file names to the FTP client side)	13-23
mput	(Writes a file)	13-23
open	(Connects with the FTP server)	13-24
put	(Writes a file)	13-24
pwd	(Displays the QnACPU current directory)	13-25
quit	(Shuts down the connection to the FTP server, and ends FTP)	13-25
quote	(Sends the FTP server subcommand (QE71 dedicated command) ...	13-25
rename	(Changes the file name)	13-25
user	(Enter the user name and password for the connected FTP server) ...	13-26
2 QE71 dedicated commands	13-26
change	(Displays/changes the file attribute)	13-27
keyword-set	(Sets/displays/clears the keyword registered to the QnACPU)	13-28
run	(Sets the QnACPU to the run state)	13-29
status	(Displays the QnACPU operation information)	13-30
stop	(Sets the QnACPU to the stop state)	13-30

CHAPTER 14. WHEN THE QnACPU ACCESSES THE REMOTE STATION PLC USING THE DATA LINK COMMAND **14- 1 to 14-49**

14.1	Remote Station Access with the Data Link Command	14- 1
14.2	Remote Station Access Function Using the Data Link Command	14- 2
14.3	Precautions When Performing Remote Station Accesses	14- 3
14.4	Data Link Commands	14- 6
14.4.1	Send/Receive Data (SEND/RECV)	14- 8
14.4.2	Read/Write Word Device of Remote Stations (READ/WRITE)	14-18
14.4.3	Read/Write Word Device of Remote Stations (ZNRD/ZNWR)	14-30
14.4.4	QnACPU Status Control	14-36
14.4.5	QnACPU Clock Data Read/Write (REQ)	14-43
14.4.6	QE71 EEPROM Data Read/Write (REQ)	14-46
14.5	Error Codes for Data Link commands	14-49

CHAPTER 15. WHEN EXCHANGING WITH MELSECNET/10 RELAY **15- 1 to 15-24**

15.1	MELSECNET/10 Relay Exchange	15- 1
15.2	Remote Station PLC Accessible Range and Stations	15- 2
15.2.1	Accessible Range and Stations	15- 2
15.2.2	Exchange Request Origin Station/Exchange Relay Station/ Exchange Request Destination Station	15- 3
15.3	Setting for Remote Station Access	15- 5
15.3.1	Setting Parameter Types	15- 6
15.3.2	Ethernet Parameters	15-10

15.3.3	Routing Parameters	15-11
15.3.4	Station No. <-> IP Information Parameters	15-13
15.3.5	Convert Format between the Network Number/ Station Number and IP Address/Port Number	15-17
15.4	Remote Access Procedure	15-23
15.5	Precautions When Performing the Remote Station Access	15-24

CHAPTER 16.WHEN EXCHANGING WHILE PLC CPU IS STOP	16- 1 to 16- 9
---	-----------------------

16.1	Data Exchange While PLC CPU is Stop	16- 1
16.2	Setting for Continuing Data Exchange	16- 2
16.3	Relationship Between the Setting and the Data Exchange When the PLC CPU is at the Stop State	16- 3

TROUBLESHOOTING SECTION (CHAPTER 17)

CHAPTER 17.TROUBLESHOOTING	17- 1 to 17-30
-----------------------------------	-----------------------

17.1	List of Error Codes	17- 1
17.1.1	End Codes Returned to the Remote Node During Data Exchange	17- 2
17.1.2	Error Codes Returned to the Remote Node by Reading and/Writing Data in the PLC CPU Using E71 Commands	17- 4
17.1.3	Error Codes Stored in the Buffer Memory	17- 5
17.2	Troubleshooting Flow	17-16
17.2.1	Transmission Error During Fixed Buffer Exchange (With Procedure/Without Procedure Commonization)	17-18
17.2.2	Reception Errors During Fixed Buffer Exchange (With Procedure/Without Procedure Commonization)	17-20
17.2.3	Errors During Random Access Buffer Exchange	17-22
17.2.4	Errors When Reading/Writing Data in the PLC CPU	17-24
17.3	Checking the Existence of Errors on the PLC Side and the Contents of Errors	17-26
17.4	How to Check an Error Through GPPW	17-27
17.4.1	Ethernet Diagnostics	17-28
17.4.2	Buffer Memory that can be Monitored with the GPPW Diagnostic Function	17-28
17.4.3	Checking the Error Information by the Buffer Memory Batch Monitoring Function	17-30

Appendix 1	Using the Existing Program and Replacing Module	APP.- 1
Appendix 2	Adding the QE71 to the Existing System	APP.- 2- 3
Appendix 3	Processing Time	APP.- 3
Appendix 4	ASCII Code Table	APP.- 9
Appendix 5	Reference Documents	APP.- 9
Appendix 6	Diagram of External Dimensions	APP.-10
Appendix 7	Sample Program	APP.-12
	7.1 Program for Reading/Writing Data in the PLC CPU	APP.-12- 2
	7.2 Sequence Programs for All Functions	APP.-21
	7.3 Program for Reading/Writing Data in the PLC CPU	APP.-29
Appendix 8	Difference between Ethernet and IEEE802.3	APP.-32
Appendix 9	QE71 Support's ICMP Protocol	APP.-32
Appendix 10	Communication Support Tool (MX Component)	APP.-33
	10.1 Overview of MX Component	APP.-33
	10.2 Usage Procedure of MX Component	APP.-36
Appendix 11	Index	APP.-40

About This Manual

Following is a list of manuals related to the Ethernet Interface Module.

Related Manuals

Manual Name	Manual No. (Model Code)	
For A Ethernet Interface Module User's Manual This manual explains the control procedures and E71 commands used when reading/writing data in the PLC CPU using E71 commands. When using E71 commands, please also refer to Chapter 9 of the User's Manual. (Sold separately)	SH-080192 (13JR45)	
MELSECNET and MELSECNET/B Data Link System Reference Manual This manual gives an overview and the specifications for MELSECNET (II) and MELSECNET/B and the procedures for setting the link parameters and operation and troubleshooting. Please read this manual when accessing other stations via data link systems. (Sold separately)	IB-66350 (13JF70)	
QnA corresponding MELSECNET/10 Network System Reference Manual This system gives an overview of and the specifications for the MELSECNET/10 and the procedures for setting and operating the parameters, and explains about programming and troubleshooting. Please read this manual when accessing remote stations via the MELSECNET/10 network system or when accessing another station using data link instructions. (Sold separately)	QnA	IB-66620 (13JF77)
	QnA /Q4AR	IB-66690 (13JF78)

Compliance with the EMC and Low Voltage Directives

When incorporating the Mitsubishi PLC into other industrial machinery or equipment and keeping compliance with the EMC and low voltage directives, refer to Chapter 3 "EMC Directive and Low Voltage Instruction" of the User's Manual (Hardware) for the CPU module used or the PLC CPU supplied with the base unit.

The CE logo is printed on the rating plate of the PLC, indicating compliance with the EMC and low voltage directives.

For making this product compliant with the EMC and low voltage directives, please refer to Section 3.1.3 "Cable" in Chapter 3 of the above-mentioned user's manual.

About the Generic Terms and Abbreviations

1 Module terms and abbreviations

This manual uses the following terms and abbreviations for the Ethernet interface module and the PLC CPU module. When display of the model name is required, the module name will be written.

Abbreviations/Terms	Descriptions/Target module	
ACPU PLC CPU	The appropriate CPU module shown in Item 2.2. Sometimes shown as CPU in diagrams. (Including PLC CPUs with MELSECNET data link functions)	
A1SJ71E71	A1SJ71E71-B5, A1SJ71E71-B2	
A1SJ71E71-S3	A1SJ71E71-B5-S3, A1SJ71E71-B2-S3	
A1SJ71QE71N-B2	A1SJ71QE71N-B2 Ethernet Interface Module	
A1SJ71QE71N-B5	A1SJ71QE71N-B5 Ethernet Interface Module	
A1SJ71QE71N-T	A1SJ71QE71N-T Ethernet Interface Module	
A1SJ71QE71N3-T	A1SJ71QE71N3-T Ethernet Interface Module	
AJ71QE71 (B5)	AJ71QE71, AJ71QE71-B5	
AJ71QE71N-B2	AJ71QE71N-B2 Ethernet Interface Module	
AJ71QE71N-B5	AJ71QE71N-B5 Ethernet Interface Module	
AJ71QE71N-T	AJ71QE71N-T Ethernet Interface Module	
AJ71QE71N3-T	AJ71QE71N3-T Ethernet Interface Module	
AJ72P25/R25	AJ72P25, AJ72R25, AJ72T25B, A1SJ72T25B	
AnA/AnU/QnACPU	AnACPU, AnUCPU, QnACPU	
AnACPU	A2ACPU, A2ACPU-S1, A3ACPU, A2ACPUP21/R21, A2ACPUP21/R21-S1 and A3ACPUP21/R21 in ACPU	
AnSCPU or AnS	A1SCPU, A1SJCPU, A1SHCPU, A1SJHCPU, A2SCPU, A2SHCPU and A2SHCPU-S1 in ACPU	
AnU/QnACPU	AnUCPU, QnACPU	
AnUCPU	A2UCPU, A2UCPU-S1, A3UCPU, A4UCPU, A2ASCPU and A2ASCPU-S1 in ACPU	
An(N)CPU or An(N)	A1CPU, A1NCPU, A2CPU, A2CPU-S1, A2NCPU, A2NCPU-S1, A3CPU, A3NCPU in ACPU	
E71 (Existing module)	AJ71E71, A1SJ71E71-B5, A1SJ71E71-B2	
E71	AJ71E71N3-T, AJ71E71N-T, AJ71E71N-B5, AJ71E71N-B2, AJ71E71N-B5T, A1SJ71E71N3-T, A1SJ71E71N-T, A1SJ71E71N-B5, A1SJ71E71N-B2, A1SJ71E71N-B5T	
E71S3 (Existing module)	AJ71E71-S3, A1SJ71E71-B5-S3, A1SJ71E71-B2-S3	
LP21/BR11	AJ71LP21 (G), AJ71BR11, AJ71LR21, A1SJ71LP21, A1SJ71BR11	
LP25/BR15	AJ72LP25 (G), AJ72BR15, AJ72LR25	
QCPU	Q-mode	Q00JCPU, Q00CPU, Q01CPU, Q02CPU, Q02HCPU, Q06HCPU, Q12HCPU, Q25HCPU, Q12PHCPU, Q25PHCPU, Q12PRHCPU, Q25PRHCPU
	A-mode	Q02CPU-A, Q02HCPU-A, Q06HCPU-A
QE71	AJ71QE71N3-T, AJ71QE71N-T, AJ71QE71N-B5, AJ71QE71N-B2, AJ71QE71N-B5T, A1SJ71QE71N3-T, A1SJ71QE71N-T, A1SJ71QE71N-B5, A1SJ71QE71N-B2, A1SJ71QE71N-B5T	
QE71 (Existing module)	AJ71QE71, AJ71QE71-B5, A1SJ71QE71-B2, A1SJ71QE71-B5	
QLP21/QBR11	AJ71QLP21 (S/G), AJ71QBR11, A1SJ71QLP21, A1SJ71QBR11	
QLP25/QBR15	AJ72QLP25 (G), AJ72QBR15, AJ72QLR25, A1SJ72QLP25, A1SJ72QBR15, A1SJ72QLR25	
QnACPU	Q2ACPU, Q2ACPU-S1, Q3ACPU, Q4ACPU, Q4ARCPU, Q2ASCPU, Q2ASCPU-S1, Q2ASHCPU and Q2ASHCPU-S1 in ACPU	

2 Other terms and abbreviations

This manual uses the following terms and abbreviations to explain the QE71 data exchange functions. When it is necessary to clearly show what is being explained the name or model name will be written.

Abbreviation/Terms		Description
Data link system		MELSECNET (II), MELSECNET/B data link systems
Data link module		MELSECNET (II), MELSECNET/B modules
External device		Remote node personal computers, computers, workstations (WS), and other QE71/E71s, etc. connected to the Ethernet to exchange data.
Ethernet		10BASE5, 10BASE2, 10BASE-T
Ethernet Address		A machine-specific address that is also referred to as the MAC (Media Access Control) address. This is used to identify the addresses of external devices over a network. The Ethernet address of the QE71 can be verified on the MAC ADD column of the rating plate.
GPP	GPPQ	SWnIVD-GPPQ, SWnNX-GPPQ GPP Function Software Package
	GPPW	GX Developer (Product after SW2D5C/F-GPPW-E)
I/F		Interface
MELSECNET		Network system, data link system
Network		10BASE5, 10BASE2, 10BASE-T, network system, data link system
Network system		MELSECNET/10 network system
Network module		MELSECNET/10 module
N/W module		

3 Terminology

For information on terminology, please use the index provided at the end of the appendixes in this manual.

Product Configuration

The following lists the product configuration of the Ethernet interface modules.

Model	Item name (*1)	Quantity
AJ71QE71N3-T	AJ71QE71N3-T Ethernet Interface Module	1
AJ71QE71N-T	AJ71QE71N-T Ethernet Interface Module	1
AJ71QE71N-B5	AJ71QE71N-B5 Ethernet Interface Module	1
AJ71QE71N-B2	AJ71QE71N-B2 Ethernet Interface Module	1
	F-type connector (A6RCON-F)	1
A1SJ71QE71N3-T	A1SJ71QE71N3-T Ethernet Interface Module	1
A1SJ71QE71N-T	A1SJ71QE71N-T Ethernet Interface Module	1
A1SJ71QE71N-B5	A1SJ71QE71N-B5 Ethernet Interface Module	1
A1SJ71QE71N-B2	A1SJ71QE71N-B2 Ethernet Interface Module	1
	F-type connector (A6RCON-F)	1

*1 For parts and materials not listed above, please contact the respective manufacturers or network vendors for purchase.

COMMON SECTION

The common section gives a summary of the functions and explains the features and system configuration, module specifications, and data exchange when exchanging data with the PLC CPU using a node external device via the Ethernet Interface Module.

Before using the Ethernet Interface Module, please read Chapters 1 through 5 once.

When booting up the system please follow the explanation in Chapter 4 to set the module switch, connect with external devices, and check operations.

Abbreviated procedures for booting up the module are given in Item 4.1.

1 GENERAL DESCRIPTION

This manual explains the specifications, functions and usage, handling, and remote node connection methods of the following Ethernet interface modules in order to send and receive data using the TCP/IP or UDP/IP communication protocol by connecting the QnA Series PLC with a computer via Ethernet. When applying the following program examples to the actual system, make sure to examine the applicability and confirm that it will not cause system control problems.

	Model	Product name (*1)	Interface (*2)		
			T	B5	B2
1	AJ71QE71N3-T	AJ71QE71N3-T Ethernet Interface Module	○	—	—
2	AJ71QE71N-T	AJ71QE71N-T Ethernet Interface Module	○	—	—
3	AJ71QE71N-B5	AJ71QE71N-B5 Ethernet Interface Module	—	○	—
4	AJ71QE71N-B2	AJ71QE71N-B2 Ethernet Interface Module	—	—	○
5	A1SJ71QE71N3-T	A1SJ71QE71N3-T Ethernet Interface Module	○	—	—
6	A1SJ71QE71N-T	A1SJ71QE71N-T Ethernet Interface Module	○	—	—
7	A1SJ71QE71N-B5	A1SJ71QE71N-B5 Ethernet Interface Module	—	○	—
8	A1SJ71QE71N-B2	A1SJ71QE71N-B2 Ethernet Interface Module	—	—	○

*1 For the package contents of each product, refer to the product configuration (previous page in the Common Edition).

*2 Indicates the communication interface of the applicable unit (○: available, —: not available).

T: 10BASE-T, B5: 10BASE5, B2: 10BASE2

Including these modules in Ethernet makes it possible to exchange data between the QnA series PLC and the computer and between QnA and A-series PLC.

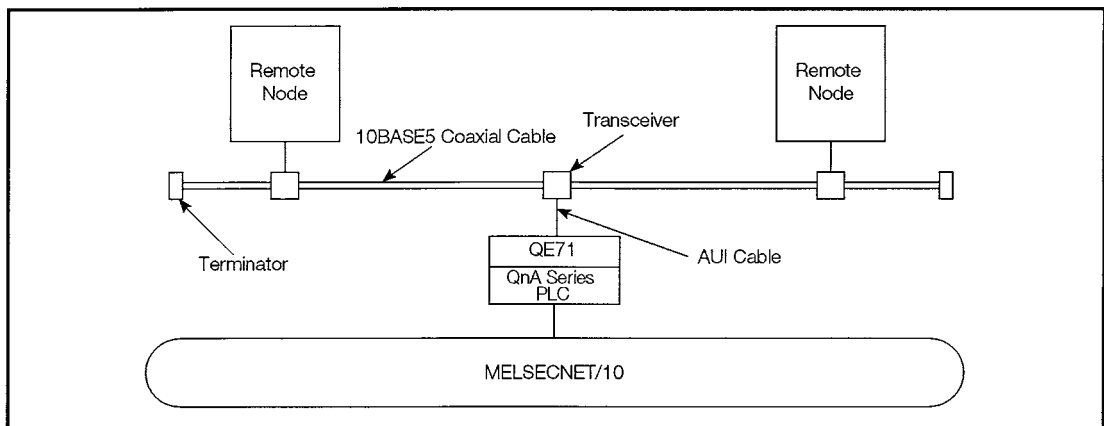

Fig 1.1 Connection Diagram Using 10BASE5 (Ethernet)

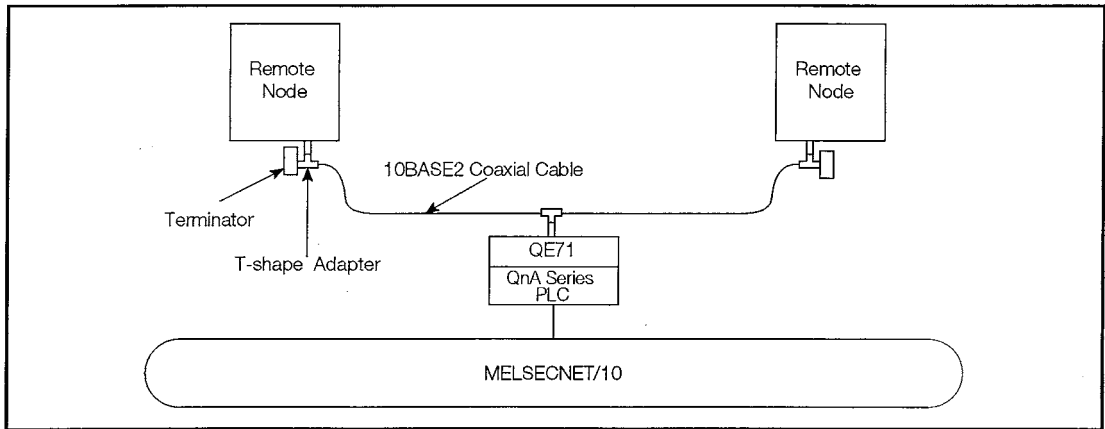

Fig 1.2 Connection Diagram Using 10BASE2 (Cheapernet)

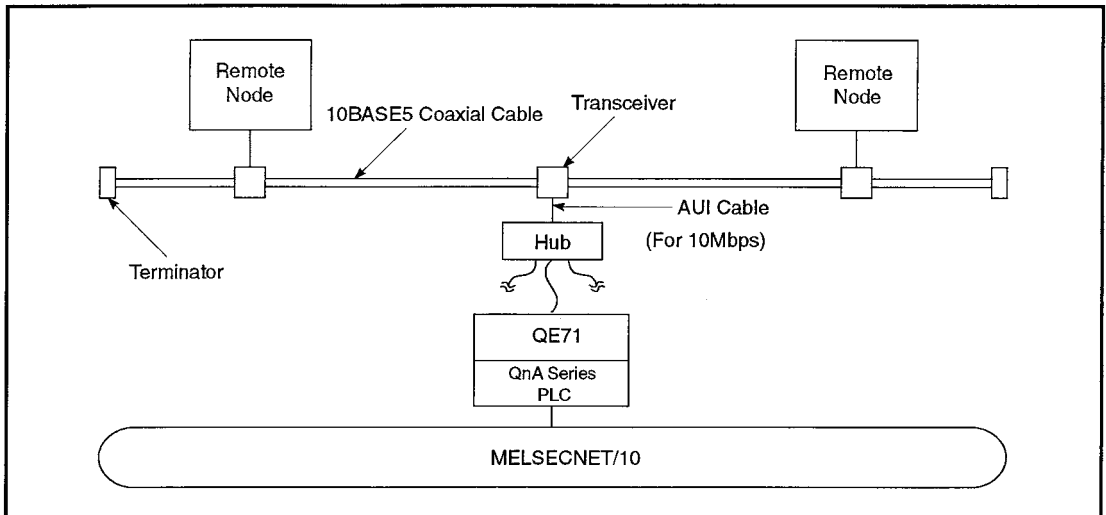

Fig 1.3 Connection Diagram Using 10BASE-T

1.1 Software Configuration

QE71 supports the TCP/IP and the UDP/IP protocols.

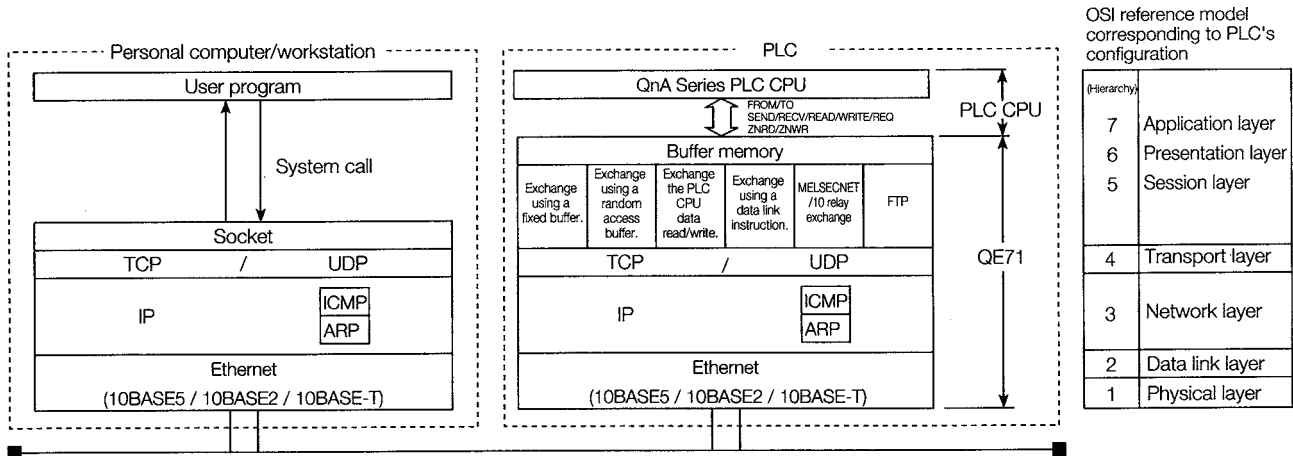

Fig 1.4 Software Configuration Diagram

* The exchange request from the QE71 installed QnACPU, fixed buffer exchange to remote nodes and exchange to remote QnACPU using data link command can be performed.

The exchange request from remote nodes, fixed buffer exchange to the PLC CPU, buffer exchange for random access, data read/write exchange in the PLC CPU, exchange using data link command, MELSECNET/10 relay exchange and FTP exchange can be performed.

1 TCP (Transmission Control Protocol)

This protocol retains the data reliability and correctness for the TCP protocol level.

- Establishing a connection creates a theoretical connection as if a special line were created between the nodes.
- A maximum of 8 connections can be established at the same time and communication to multiple buffers can be done at the same time.
- Data reliability is maintained by using a check sum for PLC control and data read transmit functions using the PLC No.
- The communication data flow can be controlled using window operations.
- Supports the Maximum Segment option.
The Maximum Segment option is enabled during TCP retransmission.
It can also be enabled during TCP transmission.
The data reception side must check the length of received data before processing the message.

2 UDP (User Datagram Protocol)

This protocol can not retain the data reliability and correctness for the UDP protocol level.

However if the data does not reach the target node it will not be retransmitted.

- Because it is connectionless, high speed transmission is possible.
- A check sum is used to increase the reliability of the communication data. However when greater reliability must be maintained, use a user application or TCP.

3**IP (Internet Protocol)**

- Data communication can be sent and received using the datagram format.
- The communication data can be divided and reassembled.
- Routing options are not supported.

4**ARP (Address Resolution Protocol)**

- A broadcast is used to find the Ethernet physical address from the IP address.

5**ICMP (Internet Control Message Protocol)**

- Has a function to transmit IP error messages.
- Please refer to the appendix for information regarding the ICMP option support type (ICMP protocol).

6**FTP (File Transfer Protocol)**

- This is the protocol that is used to transfer the file.
- The QnACPU file can be uploaded and downloaded.

1.2 Features

QE71 is a module used to connect the QnACPU (or MELSECNET/10 remote station) to the Ethernet.

By combining a QnACPU in the Ethernet it is possible to construct a network system that combines data link system/network with the Ethernet.

It is possible to conduct fixed buffer exchange with a remote node and to read and write data from the random access buffer exchange area from the PLC CPU.

Fixed buffer exchange using TCP/IP or UDP/IP, random access buffer exchange, and reading and writing data inside the PLC CPU (general data exchange) from a remote node is possible.

The main features of the QE71 are explained below.

1 **Selecting the communication format (TCP/UDP) and exchange remote node units is possible (Detailed explanation in Chapter 5)**

The QE71 has the following ports for data exchange with remote nodes.

- ① This is a port for exchanging data when opening (communication line connection) is done using the sequence program. It is possible to open 8 ports at the same time (TCP/UDP).
- ② This port is automatically opened when the QE71 installation station is booted up and automatic open UDP port is possible to be exchange data. The number of ports is 1 (UDP) and it is not included in the number of ports opened at the same time mentioned in ① above.

Reading and writing the data within the PLC CPU from the remote node is possible without conditions such as RUN/STOP status QE71 installed station, the PLC CPU.

It is possible to exchange data with data link command from the local station QnACPU.

When using the port in ① above, you can select for each port whether to use TCP/IP or UDP/IP as the communication format to use when exchanging .

The relationship between the QE71 data exchange and the selectable communication formats is shown below.

	Exchange functions		Communication method		Remarks
			TCP/IP	UDP/IP	
Communication format for the exchange functions that connect the communication line from the sequence program (User selected)	Fixed buffer exchange	With procedure	○	○	_____
		Without procedure	○	○	
	Random access buffer exchange		○	○	
	Read/write data in the PLC CPU (General data exchange)	QE71 command exchange	○	○	When the automatic open UDP port is not used.
		E71 command exchange	○	○	
Router relay exchange		○	○	_____	
MELSECNET/10 relay exchange		○	○	UDP/IP is used for exchange between QE71's that serve as relays.	
Communication format for the functions to be enabled upon completion of QE71's initial processing (Exchange using the automatic open UDP port)	Read/write data in the PLC CPU (General data exchange)	QE71 command exchange	×	○	UDP/IP is used for exchange between QE71's that serve as relays. The communication format cannot be selected by the user.
		E71 command exchange	×	○	
	Remote station access using data link commands		×	○	
	Router relay exchange		×	○	
MELSECNET/10 relay exchange		×	○		
Communication format for the functions to be enabled upon completion of QE71's initial processing	File transfer (FTP server function)		○	×	The communication format cannot be selected by the user.

2

Data exchange at 1:1 or 1:n to the remote node (Fixed buffer exchange)

- (a) When the QE71 fixed buffer is used data for exchange between a remote node and the QnACPU at 1:1 or 1: n.
- (b) The QE71 is set with 8 fixed buffers with a memory capacity of 1k words, with a remote node for communicating with each fixed buffer, application (transmission/reception), and the usage protocol (TCP/UDP); data can be transmitted and received to and from multiple nodes at the same time. (Exchange between QE71 and another QE71 is possible.)
- Two fixed buffers are required when transmitting or receiving from the same remote node.
- (c) When exchanging with fixed buffers, exchange can be done using either the QE71 procedure (with procedure) or without procedures.

(Please refer to Item 3.3 for details regarding the amount of data that can be transmitted at one time.)

- ① When exchanging with procedure (Detailed explanation in Chapter 6)

The QE71 protocol transmits and receives data on a 1:1 basis using a handshake between the specified node and the QnACPU.

Use when transmitting or reception data easily from the Sequence program.

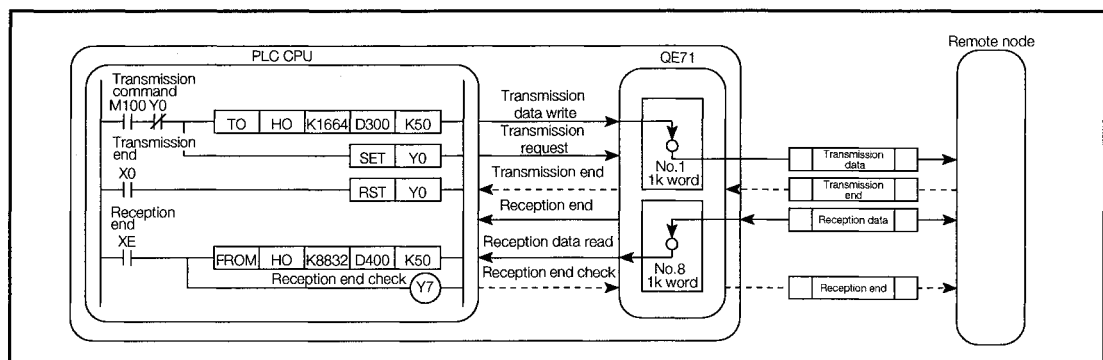

Fig 1.5 Fixed Buffer Exchange (With Procedure)

- When transmitting data
 - After writing the transmission data in the fixed buffer, the transmission request signal will turn on and data of the specified number of words will be transmitted.
 - When a transmission end response is received from the remote node the transmission end signal will turn on.
- When receiving data
 - When the data of the specified number of words is stored in the reception fixed buffer, the reception end signal will turn on.
 - When the reception data is read from the fixed buffer and the reception end check signal is turned on, the reception end check response will be sent and the reception end signal will be turned off.

② When exchanging without procedure (Detailed explanation in Chapter 7)

Data transmission is conducted when the specific node and the PLC CPU are 1:1 or 1:n by simultaneous communication. (Simultaneous transmission function, refer to [7])

Used to transmit fixed buffer data or to put reception data in the fixed buffer the way it is received.

Because it is without procedure the handshake with the remote node must be done by the sequence program.

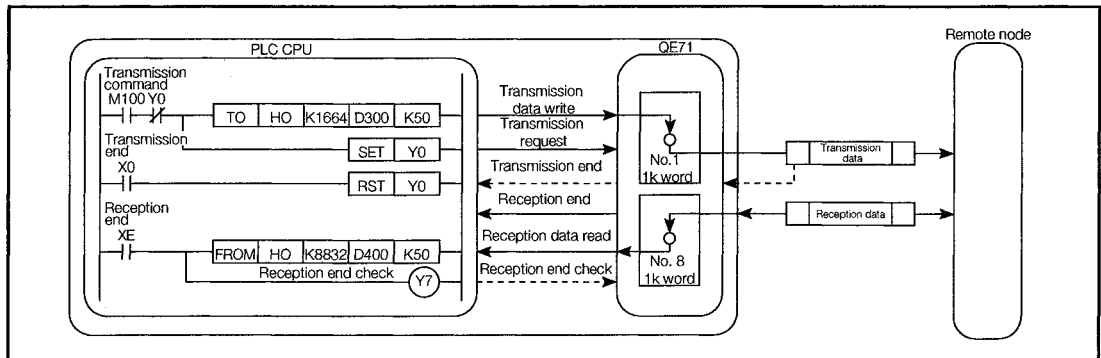

Fig 1.6 Fixed Buffer Exchange (Without Procedure)

- When transmitting data

After the transmitted data is written in the fixed buffer and the transmission request signal is turned on, the data of the specified number of words is transmitted and the transmission end signal is turned on.

The transmission end response does not wait for a reception signal.

- When receiving data

When the data of the specified number of words is received and stored in the fixed buffer, the reception end signal is turned on.

When the reception data is read from the fixed buffer and the reception end check signal is turned on, the reception end signal turns off.

The reception end response is not sent.

3

Data exchange from a read/write request from a remote node (Random access buffer exchange : detailed explanation in Chapter 8)

Use when processing the maximum 6k word data quantity with the sequence program and when processing transmission and reception data when the sequence program and the remote node are non synchronous.

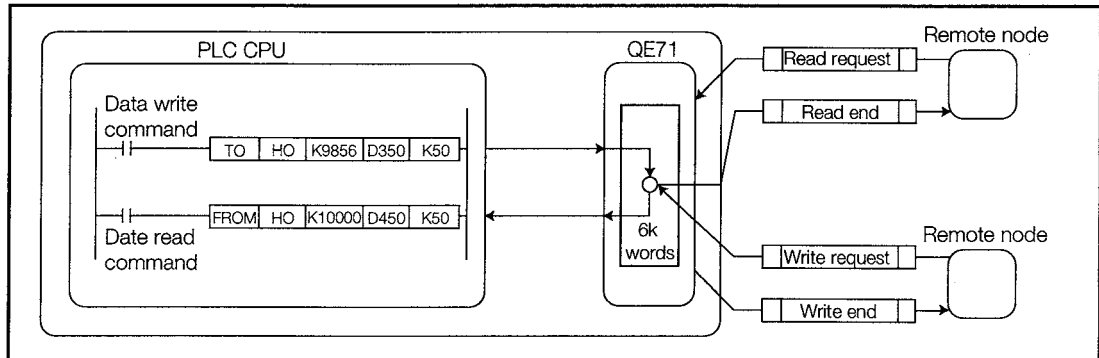

Fig 1.7 Random Access Buffer Exchange

- (a) The random access buffer can read and write the same address to multiple nodes. However, exchange between the PLC CPU and the remote node is non synchronous so the user must conduct interlock processing.
- (b) The random access buffer is 6k words.
The area is not set for each connection as for fixed buffer exchange.
- (c) The PLC CPU processing when data is transmitted and received is as follows.
 - When transmitting data
The transmitted data can be written into any area of the random access buffer by sequence program.
When a read request is received from a remote node the data written in the specified area of the random access buffer is transmitted as read end response.
 - When receiving data
When a write request is received from a remote node the reception data is stored in the specified area of the random access buffer and a write end response is transmitted.
The reception data can be read from the random access buffer by sequence program.
- (d) Writing to and reading from the random access buffer from a remote node can be freely done between nodes set in the QE71 parameter.
For this reason, the random access buffer can be used to store common data and to receive and relay data between remote nodes. (There is no need to use the PLC CPU memory.)

4

Reading and writing inside the PLC CPU via a request from a remote node (general data exchange : detailed explanation in Chapters 9 and 10)

Use to read and write remote station PLC data via local station PLC installed in the QE71 and data link systems/network systems from the remote node with MITSUBISHI MELSEC communication support tool (*1) inserted. In addition, the PLC CPU state can be controlled from a remote node using remote RUN/STOP, etc.

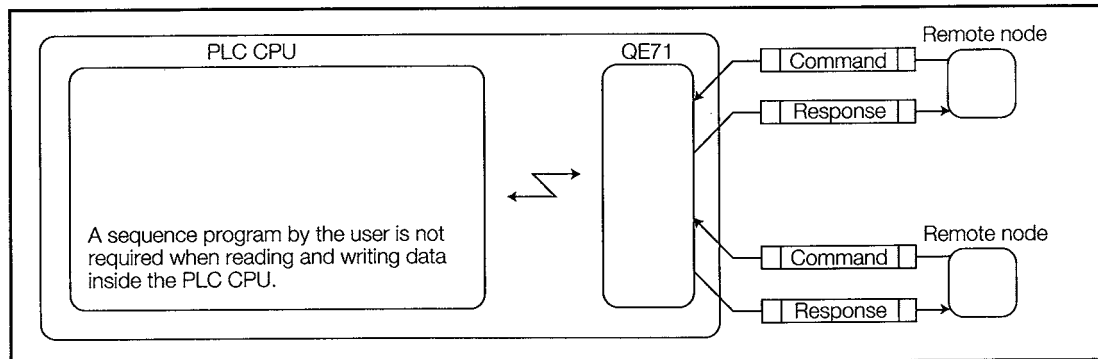

Fig 1.8 Reading and Writing the PLC CPU

- When a remote node transmits a request for a read/write of data inside the PLC CPU to the QE71, the data in all devices, programs, comments, and parameters is transmitted to or received from the QE71.
- When the PLC CPU installed in the QE71 is connected to a data link system or a network system, data can be exchanged to and from the remote PLC CPU. (For details refer to Item 9.1.)
- Because all data exchange are conducted between QE71 and remote nodes, the sequence program is used only for initial processing and open processing for a communication line, then data exchange can be started. There is no need to create a special sequence program for data exchange.

*1 Communication programs in the personal computers to be connected to Ethernet or computer link can be simplified by using the following communication support tools manufactured by Mitsubishi Electric, which support communication between MELSEC-A or QnA series PLC and personal computers.

- MX Component (SW0D5C-ACT-E or later)

The overview and application examples of basic communication support tools are shown in Section 10 in the Appendix. Refer to it as needed.

5 Data exchange using sequence program
(Data link command exchange : detailed explanation in Chapter 14)

The data of the PLC CPU installed in the QE71 station can be transmitted and received via Ethernet using the sequence program data link commands (SEND, RECV, READ, WRITE, REQ, ZNRD, and ZNWR). In addition, data of PLC CPUs not installed in the QE71 can be transmitted and received via Ethernet and data link systems/network systems.

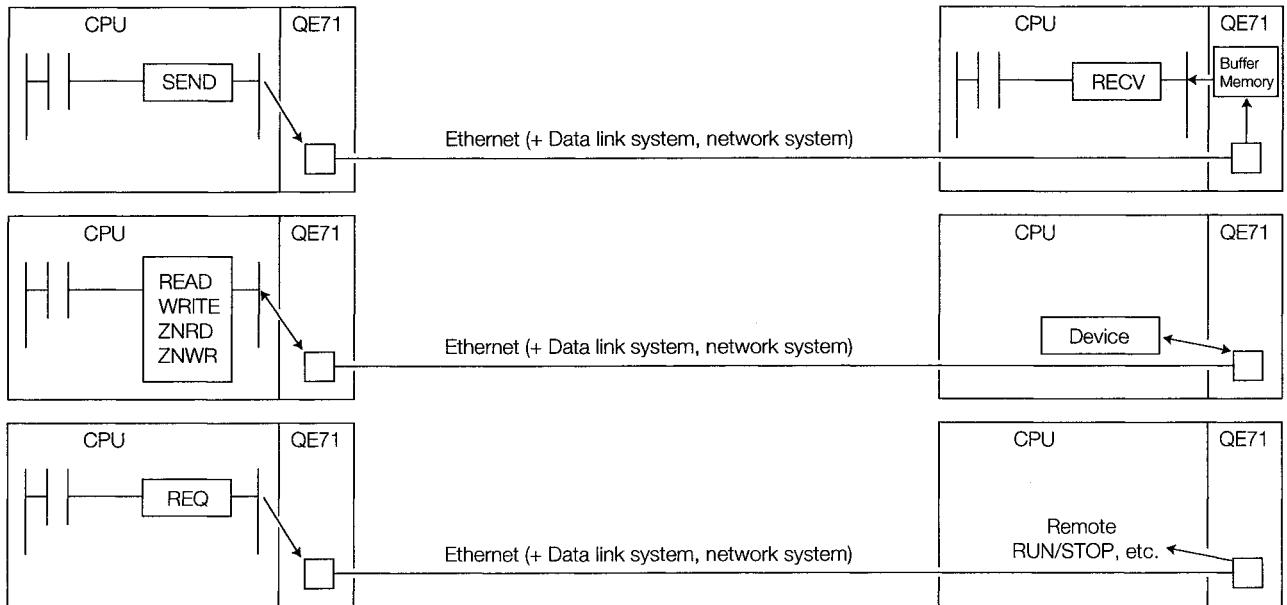

Fig 1.9 Data Link Command Exchange

6

File transfer (FTP server functions : detailed explanation in Chapter 13)

Supports the TCP/IP standard protocol's FTP (File Transfer Protocol) server functions. The FTP commands are protocol that are used to transmit data in the file units, which makes it possible to easily read and write QnACPU files.

This makes it possible to manage QnACPU files using a remote node (workstation, etc.), and to transmit files and review file lists when necessary. (All the files that are used by QnACPU, such as parameters, sequence programs, and data files, can be accessed using the FTP commands.)

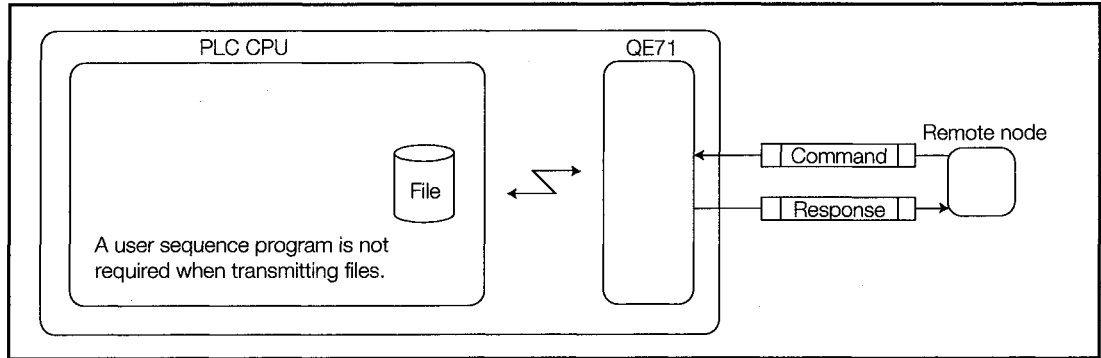

Fig 1.10 File Transmission

FTP Server and client

The node (QE71) that supplies the file transmission service is called the FTP server, and the remote node (other device such as workstation or personal computer) that requests the file transfer service is called the FTP client.

The QE71 supports the FTP server (subset) functions, and can use FTP commands from a remote node to access files in the QnACPU.

7

Simultaneous broadcast function (Simultaneous broadcast communication)

This is a function available in the following data exchange functions by UDP/IP that is used to broadcast the data simultaneously to all remote nodes on the same ethernet (excluding router relay and MELSENET/10 relay) as the exchange request origin.

- Exchange using without procedure fixed buffer (Refer to **1**) **2**)
- Exchange using data link instructions (Refer to **5**))

This function enables remote RUN/STOP for synchronization at all the stations and the same data write to all the stations.

However, the remote node will determine whether a received message is required for simultaneous broadcast, and if it is not, read and delete processing must be performed.

8

Selecting the exchanged data's data code (Detailed explanation in Item 3.3)

Use the following functions to select an exchange data code (ASCII code/binary code) that matches that of the remote node when exchanging data between the QE71 and the remote node (except for MELSENET/10 relay exchanges).

- Fixed buffer exchange with procedure (Refer to **2**) **1**)
- Random access buffer exchange (Refer to **3**))
- Reading/writing data from the PLC CPU using a request from a remote node (Refer to **4**))

(File transmission follows the FTP protocol and the exchange data code (ASCII/binary code) can be selected using FTP commands.)

Code conversion during exchange is conducted by the QE71 and all data received between the QE71 and PLC CPU is in binary code.

For this reason, a sequence program for code conversion is not required. However, the selection of exchange data codes is done on a unit basis so selection for each port cannot be done.

9 MELSECNET/10 relay exchange (Detailed explanation in Chapter 15)

Used when Ethernet and MELSECNET/10 are mixed in a network system or when there are multiple Ethernet relays in a network system.

This function enables the following data exchange by relaying networks using the user-specified network number and station number in the same way used for MELSECNET/10. (The maximum number of relays is seven, and the QE71 and QLP21/QBR11, etc. can be relayed.)

- Data read/write exchange within the PLC CPU using QE71 commands issued from remote nodes (Refer to **4**)
- Exchange to remote station's PLC CPU using data link commands from the QnACPU at the QE71 installed station (Refer to **5**)
- Exchange from GPPW, etc. connected to the QnACPU

Read/write of programs and data to remote stations via Ethernet, PLC CPU status control, etc.

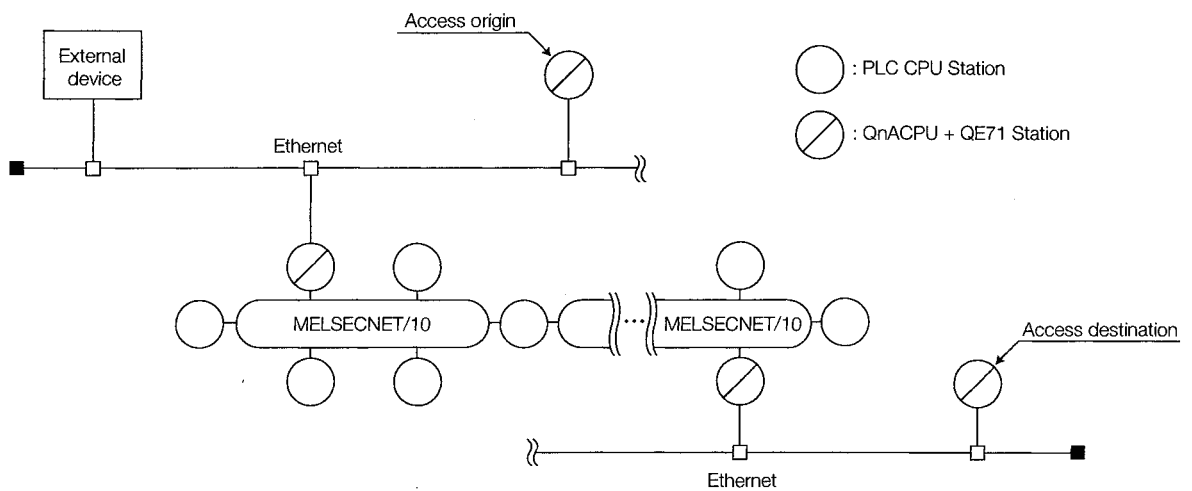

Fig 1.11 Relay Exchange Between MELSECNET/10

10 Router relay function (Detailed explanation in Chapter 12)

Used when exchanging by relaying the router.

This function does not operate as a router but is a function to make exchange via routers and gateways.

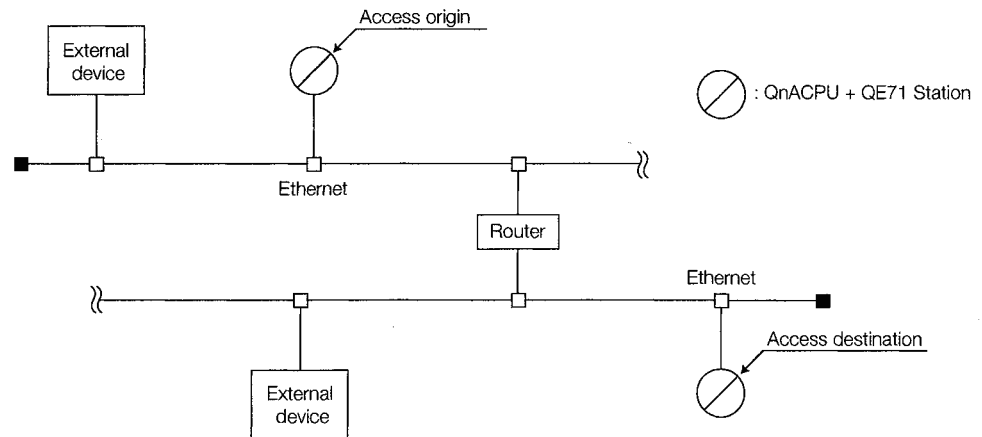

Fig 1.12 Router Relay Function

11 Exchange while the PLC CPU is in the STOP status (Detailed explanation in Chapter 16.)

This exchange is used to continue data exchange from remote nodes to the QE71, after the QnACPU at the QE71 installed station is in the STOP status, or after the open request signals (Y8 to YF)/initial request signal (Y19) from the QE71 are turned off.

This exchange is used for communication lines for which open processing has been completed by the user.

The function enables remote RUN/STOP of the QnACPU from remote nodes and rewrite of sequence program files.

12 Partner remote node existence check function (Detailed explanation in Item 5.2.2)

Used to have the QE71 regularly check if the other remote node for which the connection was made exists.

When exchange has not been conducted with the other node for a specified period of time the QE71 checks whether the node is operating properly.

When the other node is not operating properly the QE71 closes the line (connection forced disconnect).

13 Built-in EEPROM

The QE71 has a built-in EEPROM to hold the various data exchange settings (parameters) stored in the buffer memory.

Registering the parameters in the EEPROM makes the following possible.

- (a) Sequence program reduction (Detailed explanation in Item 4.9)

The parameters registered in the EEPROM are used as the buffer memory default values when the QE71 is booted up. This makes it possible to eliminate the parameter setting program that is read into the buffer memory when the QE71 is booted up.

- (b) Data exchange without sequence program (Detailed explanation in Item 5.7)

When the QE71 is booted up, UDP/IP can prepare a port in the open end status. (Sequence program initial processing and port open processing are not required.)

This makes it possible to read and write data in the PLC CPU with a request from a remote node regardless of the local station PLC CPU RUN/STOP state. However, that exchange can only be done using UDP/IP.

14 Strengthening RAS (Detailed explanation in Item 5.6.2)

A maximum of 16 sets of error history information, such as subheaders when data exchange errors are generated and the remote node IP address, can be stored in the buffer memory. This error history information makes it easy to analyze the causes of data exchange trouble.

15 Accessing a PLC CPU from GPPW through Ethernet connection (Detailed explanation in the GPPW Manual)

Access can be made to other station's PLC CPU on the MELSECNET/10 or MELSECNET (II) via the QnACPU of a station equipped with a QE71 or via a station equipped with a QE71 through Ethernet connection from GPPW.

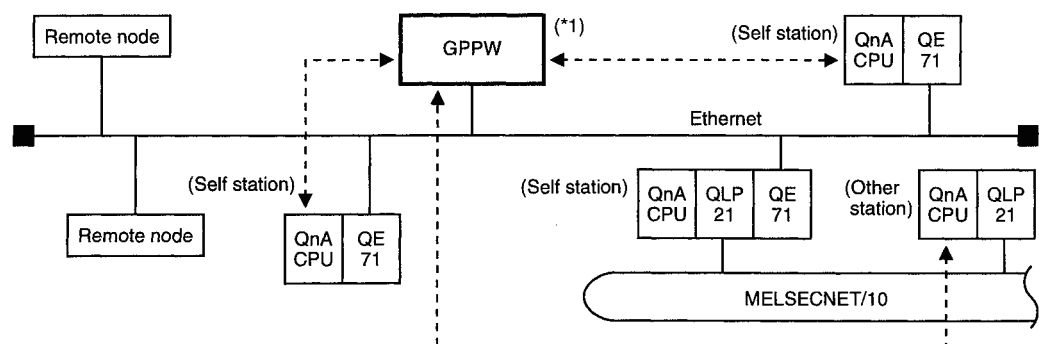

*1 Indicates a personal computer in which the following software is installed:

GPPW: GX Developer (Product after SW2D5C/F-GPPW-E)

1.3 Comparison with Existing Modules

The following describes the differences of the product from the conventional Ethernet interface module, focusing on the QE71.

Regarding the same function, if there is a circle in the model column, that means the function is compatible for the version.

○ : Function supported × : Function not supported

	Data exchange function	E71 (Existing module)	E71S3 (Existing module)	E71	QE71 (Existing module)		QE71 (This module)	Remarks
					Modules before 9706	Modules after 9707B		
1	Function to select a communication format by partner remote node units	○	○		○	○	○	—
2	Fixed buffer exchange	with procedure	○	○	○	○	○	
		without procedure	×	○	○	○	○	
3	Random access buffer exchange	○	○		○	○	○	
4	Data read/write in the PLC CPU	○	○		○	○	○	General data exchange function
5	Data link command exchange	×	×		×	○(*2)	○(*2)	For exchange between QnACPU's
6	File transfer	×	×		×	○	○	FTP server function
7	Simultaneous broadcast communication	×	○		○	○	○	—
8	Exchange while the PLC CPU is in the STOP status	×	○		×	○	○	
9	Selection of data code exchange (ASCII/binary)	○	○		○	○	○	
10	MELSECNET/10 relay exchange	×	×		×	○(*2)	○(*2)	
11	Router relay exchange	×	○		○	○	○	Router relay function
12	Partner remote node existence check function	×	○		○	○	○	—
13	Exchange by pairing open	×	○		○	○	○	For exchange using fixed buffer
14	Unit of the set value for each timer for data exchange	500ms	×(*1)	○	○(fixed)	○(fixed)	○(fixed)	—
		2S	○(fixed)	○	×	×	×	
15	Built-in EEPROM	×	×		○	○	○	Registering exchange parameters exchange without a sequence program
16	Strengthening RAS	×	○		○	○	○	Storing error history to buffer memory
17	Parameter setting	GPPQ	×	×	×	○	○	Refer to Item 2.2 for GPP that can be set.
		GPPW	×	×	×	○	○	Refer to Item 3.7.2 for the parameter that can be set.
18	Ethernet connection for GX Developer (Product after SW2D5C/F GPPW-E)	×	○		×	○	○	Connection via Ethernet
19	Ethernet connection for MX Component	○	○		○	○	○	There are some restrictions. For more details, refer to the manual of each product.
20	Accessing remote station from MELSOFT product	GX Developer	×	○	×	○	○	
		MX Component	○	○	○	○	○	
21	Connection line with remote node	10BASE2	○	○	○	○	○	Interface residing in the module
		10BASE5	○	○	○	○	○	
		10BASE-T	×	×	○	×	×	

*1 If the module software version is before Q.

*2 The manufactured date and software versions of PLC CPU and GPP are relevant when using this function. Refer to Item 2.2.

Remarks

- (1) The QE71 (this product) has the same functions as those of the function version B product of the QE71 (existing module). However, the QE71 (this product) and the QE71 (existing module) have different response speeds. For the module compatibility and the diversion of programs for conventional products, refer to Appendix 1.
- (2) Refer to the appendix when diverting programs residing at the remote nodes of data exchange with the A series Ethernet interface module (including AJ71E71) or QE71 (existing module) into programs for the data exchange with QE71 (this model).

2. SYSTEM CONFIGURATION

This section explains the system configurations that are possible in combination with the QE71.

2.1 Overall Configuration

Following is shown a system configuration with a QE71 PLC installed in the Ethernet.

Please refer to Item 2.3 for information regarding other arrangements that must be made by the user.

1 When connecting the PLC CPU with the Ethernet

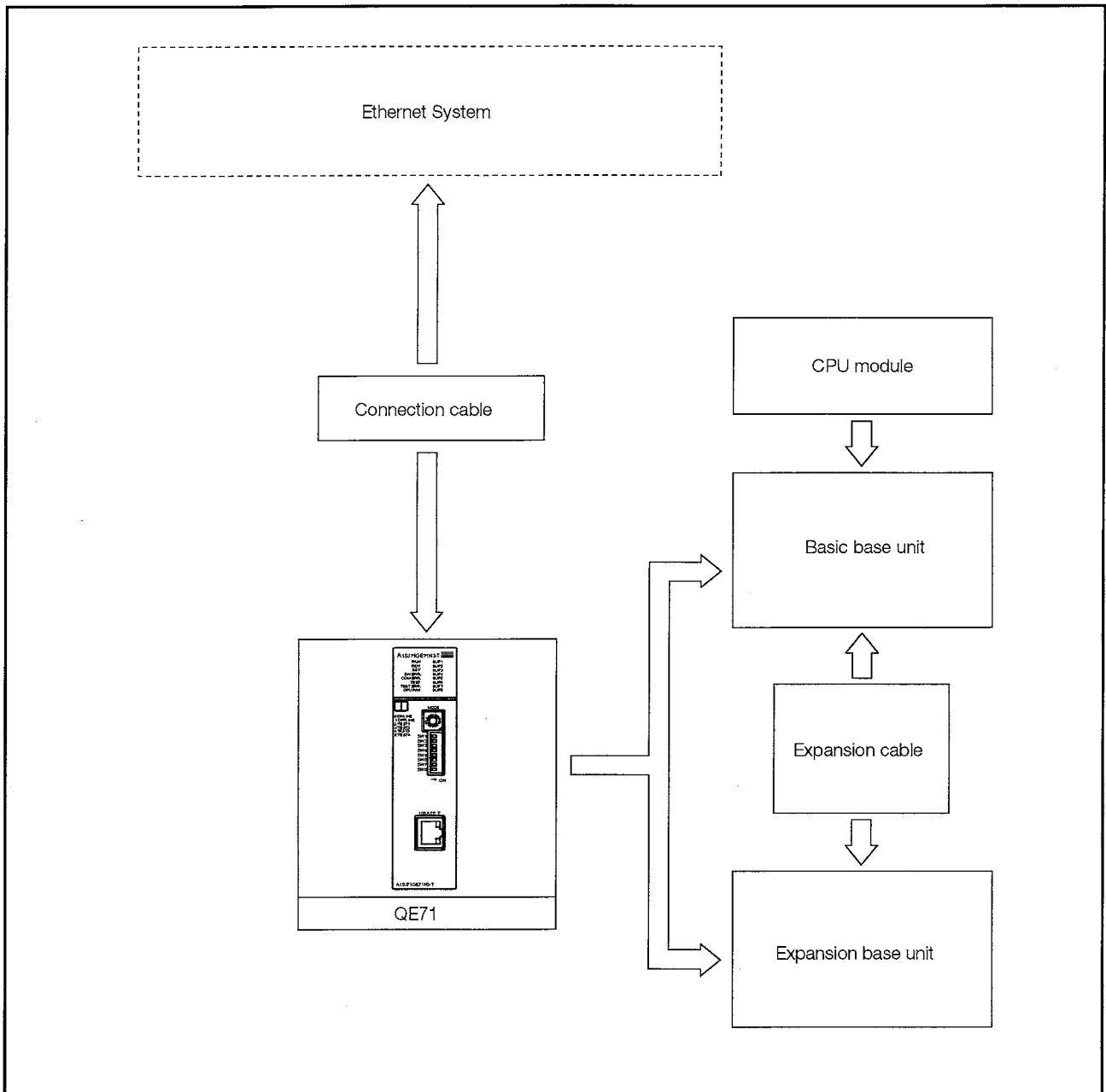

Fig 2.1 System Configuration Diagram-1

2 When connecting MELSECNET/10 remote station to the Ethernet

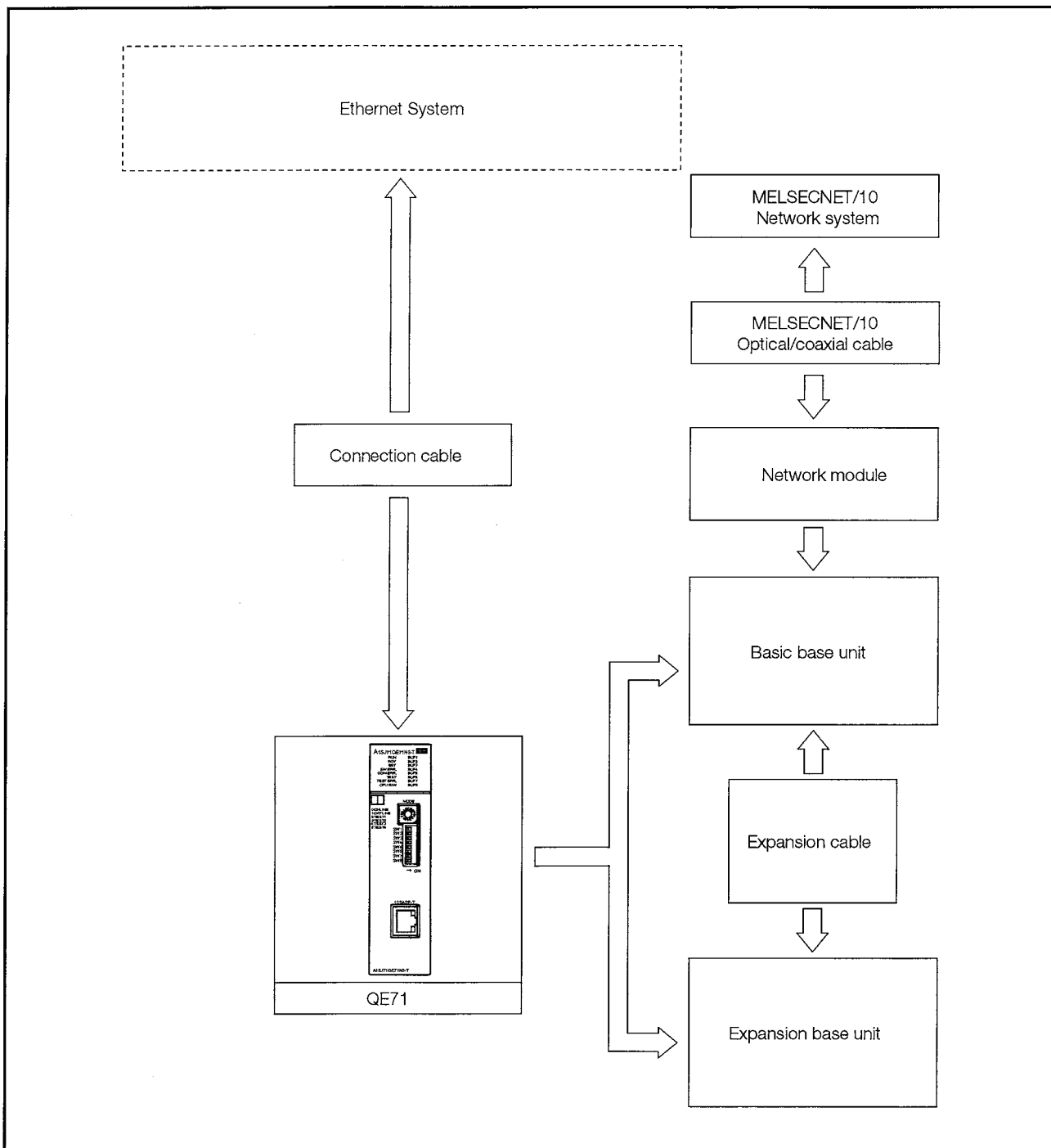

Fig 2.2 System Configuration Diagram-2

2.2 Supported Systems

The QE71 can be used for the system described below.

1 Supported modules and installable number of modules

The following table shows the PLC stations that can be installed in the QE71 and the number that can be installed.

Supported modules	Installable number of modules	Remarks
CPU module	4 modules	<ul style="list-style-type: none"> Can be installed in the range of the CPU module and remote station usable number of input signals.
Network module (MELSECNET/10)	3 modules	<ul style="list-style-type: none"> The number of modules which are used are included in network modules and data link modules.

*1 Refer to Item 2.5.3 (2).

2 Installable base units

Except where noted below the basic base unit and the expansion base unit can be freely used in installation slots of the QE71.

- (a) Installing the expansion base unit (models A52B, A55B, A58B etc.) without a power supply module could make the amount of power supply insufficient, so doing so should be avoided as far as possible. If this module is installed be sure to give sufficient consideration to the current capacity of the base unit's power supply module, and the expansion cable voltage drop when selecting the expansion cable. (For details to the usable CPU module's users manual) (Refer to **1**.)
- (b) The QE71's PLC CPU can be installed in the QnACPU based unit and the QnA supporting MELSECNET/10 remote station. It cannot be installed in PLC CPU stations other than QnACPU or in MELSECNET (II) and MELSECNET/B remote stations.

3 Accessible PLC

This shows the remote station PLC that can be accessed via a QE71 installable station from a remote node. Each accessible CPU module has a module that includes MELSECNET link functions.

(Example) In the case of the A3ACPU, the A3ACPUP21 and A3ACPUR21 can be accessed.

① PLC CPU

PLC CPUs that can be accessed from remote nodes can also be accessed via data link systems and network systems. The PLC CPU's device memory and special functions module's buffer memory can be accessed.

PLC CPU	A0J2H	A1	A1N	A1S(S1)	A1SJ(S3)	A1SH	A1SJH
	A2(S1)	A2N(S1)	A2A(S1)	A2U(S1)	A2S(S1)	A2SH(S1)	A2AS(S1)
	A2C	A2CJ(S3)		A3	A3N	A3A	A3U
	A3H	A3M	A4U				
	Q2A(S1)	Q2AS(S1)	Q2ASH(S1)	Q3A	Q4A	Q4AR	

② Remote station

Shows the remote stations that can be accessed from a remote node via the data link system and network system. The buffer memories of the special functions modules of the remote stations that are connected by the link modules that are named below can be accessed.

MELSECNET/10	AJ72QLP25(G) AJ72BR15 A1SJ72QLR25	AJ72QBR15 AJ72LR25	AJ72QLR25 A1SJ72QLP25	AJ72LP25(G) A1SJ72QBR15
MELSECNET (II)	AJ72P25	AJ72R25		
MELSECNET/B	AJ72T25B	A1SJ72T25B		

③ Relay module

Shows the link modules that can relay between each network system when remote station PLC are accessed from remote nodes via MELSECNET and Ethernet network systems. Relayed systems can be accessed by the link modules named below.

MELSECNET/10	AJ71QLP21(S/G) AJ71LR21 A1SJ71BR11	AJ71QBR11 A1SJ71QLP21	AJ71LP21(G) A1SJ71QBR11	AJ71BR11 A1SJ71LP21
MELSECNET (II)	AJ71AP21	AJ71AR21	A1SJ71AP21	A1SJ71AR21
MELSECNET/B	AJ71AT21B	A1SJ71AT21B		
Ethernet	AJ71QE71N-B2 A1SJ71QE71N-B5 AJ71QE71N-B5T A1SJ71QE71N3-T	AJ71QE71N-B5 A1SJ71QE71N-T AJ71QE71-B5 A1SJ71QE71N-B5T	AJ71QE71N-T AJ71QE71 A1SJ71QE71-B2	A1SJ71QE71N-B2 AJ71QE71N3-T A1SJ71QE71-B5

4 Applicable software packages

The following table lists the software packages that support the QE71.

(a) Software package for the PLC (for parameter setup) (*1)

Item name	Model name	Remark
GX Developer	SWnD5C/F-GPPW-E	MELSEC PLC programming software. The "n" in the model name must be 2 or greater. Abbreviated as GPPW in this document.
GPP function software package	SWnIVD-GPPQ	MELSEC PLC programming software The "n" in the model name must be 2 or greater. Abbreviated as GPPQ in this document.

*1 For the restrictions on the PLC software that can set up the parameters for the QE71 to be written to the QnACPU, see Item 4.8.

(b) Communication support tools for remote nodes

Item name	Model	Remark
MX Component	SWnD5C-ACT-E	Active X control library. The "n" in the model name is 0 or greater. (*1)

*1 Depending on the version of MX Component used, different versions of QE71 are supported. Refer to the manual of MX Component for the details.

2.3 Devices Required for Network Configuration

1 The device shown in Fig 2.3 are required when connecting to 10BASE5. The user will please make the arrangements.

(a) Only use 10BASE5 coaxial cable, N-type connectors, N-type terminators, transceivers, AUI cable (transceiver cable) that meet Ethernet standards. Please use transceivers that have functions that are generally called SQETEST or Heartbeat (transceiver function that uses a signal to check if the transceiver is operating correctly after transmission).

(SQETEST : Signal Quality Error TEST)
 SQETEST = ON, or Heartbeat signal = valid

		10BASE5			
Transmission medium	Coaxial cable (Ethernet standard cable)				
	50 Ω				
AUI cable (Transceiver cable)	Twisted pair cable with 15 pin D connector				
	*QE71s AUI cable connector layout				
		Pin No.	Signal name	Pin No.	Signal name
		1	FG	9	Collision detection (-)
		2	Collision detection (+)	10	Transmission (-)
		3	Transmission (+)	11	N.C.
		4	N.C.	12	Reception (-)
		5	Reception (+)	13	+12V
		6	12G	14	N.C.
		7	N.C.	15	N.C.
	8	N.C.	Shell	FG	

(b) Please use cable that meets the transceiver and AUI cable specifications for the transceiver supply power.

Use the AJ71QE71N-B5 in consideration of the voltage drop (maximum 0.8V) of the AJ71QE71N-B5 module.

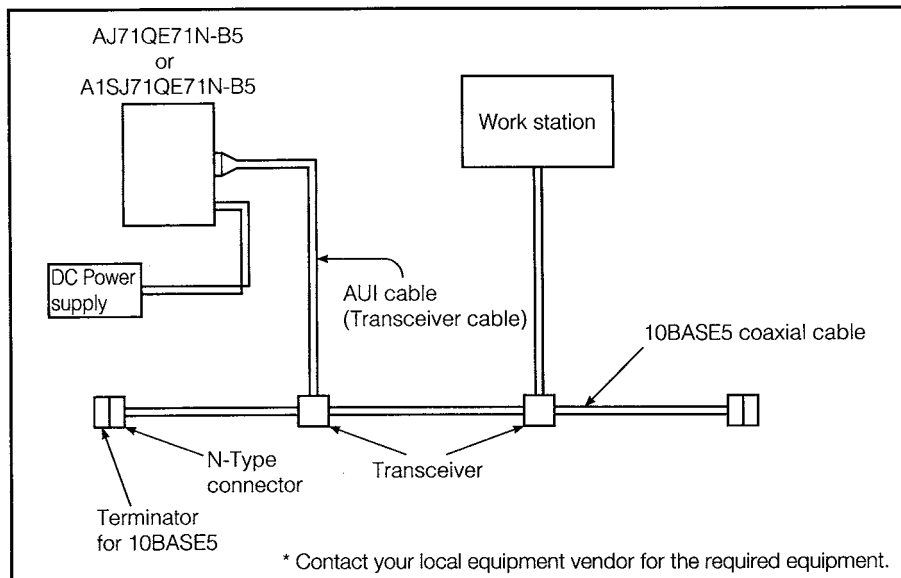

Fig 2.3 Example System Configuration

Remarks

The transceiver power characteristics are

- Input terminal voltage 12V^{-6%} to 15V^{+5%}
- AUI cable direct current resistance 40 Ω/km or under, maximum length 50m
- Maximum current consumption 500mA or less

Thus, the applicable transceiver supply power will be from 13.28 V to 15.75 V.

Since the 0.8V voltage drop of the AJ71QE71N-B5 module is considered for the AJ71QE71N-B5, the guideline of the transceiver supply power is 14.08V to 15.75V.

* Calculating the voltage drop (V) of the transceiver supply voltage

$$\text{Voltage drop (V)} = \text{AUI cable direct current resistance } (\Omega/\text{m}) \times \text{AUI cable length (m)} \\ \times 2 \text{ (both directions)} \times \text{transceiver consumption current (A)} + \text{AJ71QE71N-} \\ \text{B5 module voltage drop (V)}$$

(Example) When using the A1SJ71QE71N-B5

$$2.0 \text{ (V)} = 0.04 \text{ } (\Omega/\text{m}) \times 50 \text{ (m)} \times 2 \times 0.5 \text{ (A)}$$

In this case, the target value of the transceiver supply power will be larger than 13.28 V.

$$13.28 \text{ (V)} = 12\text{V}^{-6\%} \text{ (11.28 V)} + 2.0 \text{ (V)}$$

2 The device shown in Fig 2.4 are required when connecting to 10BASE2. The user will please arrange other than the F-type connector.

(a) 10BASE2 coaxial cable

	10BASE2
Transmission medium	Coaxial cable 50 Ω RG58A/U or RG58C/U

(b) F-type connector (for connecting to the QE71, included in the packaging)

A6RCON-F suitable products

(c) Terminator for 10BASE2 (BNC plug terminator for 10BASE2)

221629-4 (Tyco Electronics AMP K. K.) or equivalent product.

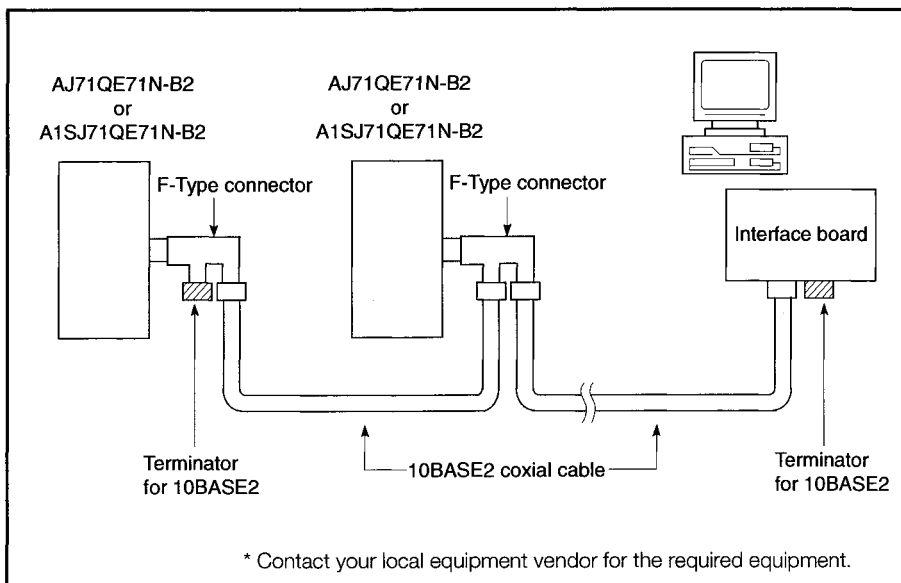

Fig 2.4 Example System Configuration

3 The devices shown in Figure 2.5 are required when connecting to the 10BASE-T. The user will please arrange the required devices in advance.

(a) Use devices that meet the standard of the 10BASE-T communication interface in IEEE802.3.

(b) Hub

Use a hub that supports 10Mbps.

(c) Twisted pair cables

① Unshielded twisted pair cable (UTP) or shielded twisted pair cable (STP) category 3, 4, 5

* Straight cables can be used.

(Correct operation is not guaranteed if a crossed cable is used to connect to an external device via the 10BASE-T of the QE71. However, it is possible to use crossed cables to connect to a QE71 module for data communication or to connect to a GOT.)

② RJ45

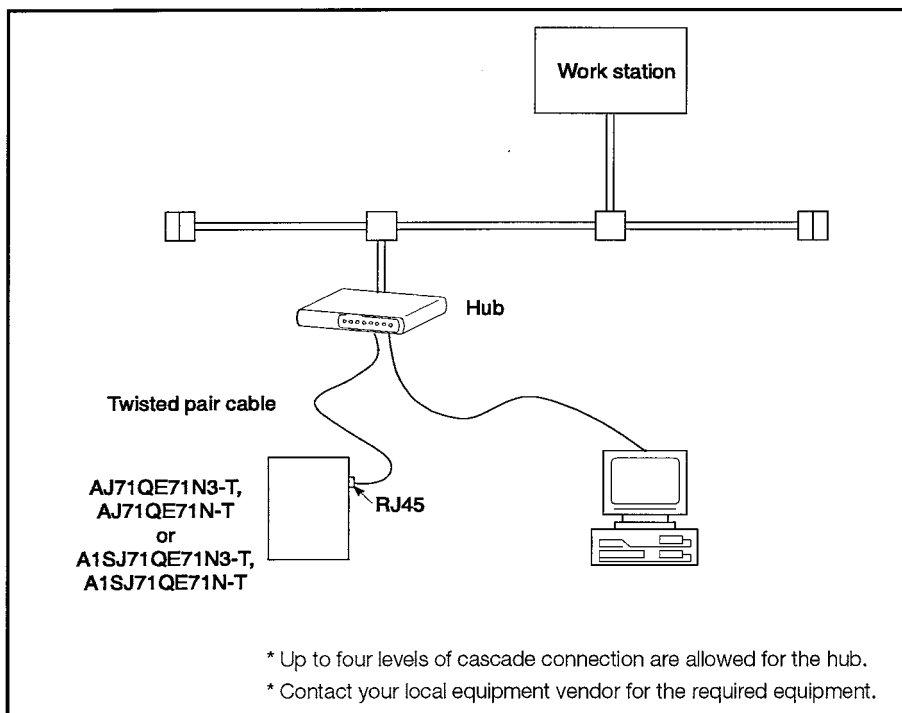

Fig 2.5 Example System Configuration

2.4 Access to the QCPU and the MELSECNET/H Remote I/O Station

This section explains about the access to the QCPU of other station and the MELSECNET/H remote I/O station via a station in which a QE71 is installed and via an Ethernet or MELSECNET/H (MELSECNET/10 mode).

Please skip this section if no access will be made to the QCPU of other station and the MELSECNET/H remote I/O station.

1

Access to the QCPU

(a) Available exchange functions of the QE71

- Read/write data exchange in the PLC CPU
- Fixed buffer exchange (with procedure, without procedure)
- Data link command exchange
- Router relay exchange
- MELSECNET/10 relay exchange

(b) Actions of the QE71 for the QCPU

The following table shows the actions of the QE71 when accessing the QCPU from a remote node via the local station installed with a QE71.

Exchange function used	Access destination	QCPU (other station)	
		QCPU (Q mode)	QCPU (A mode)
Read/write data exchange in the PLC CPU	E71 command	Can be accessed as A3ACPU (*1) (*2)	
	QE71 command	Can be accessed as Q4ACPU (*3) (*4)	Can be accessed as A3ACPU (*2)
Data link command exchange		Can be accessed as Q4ACPU (*3)	Cannot be accessed

*1 Using the E71 command shown in Section 9.2.2, access can be made to the QCPU's device memories shown by *5 in Section 9.2.2.

However, access cannot be made to the following devices among the device memories shown by *5 in Section 9.2.2 for the Q00J/Q00/Q01 CPU:

- Special relays (M9000 to M9255) cannot be accessed.
- Special registers (D9000 to D9255) cannot be accessed.

*2 Replace the target QCPU with the A3ACPU in the explanation of this document.

*3 Replace the target QCPU with the Q4ACPU in the explanation of this document.

*4 Access can be made to the buffer memory of the intelligent function module/special function module installed in the QCPU station.

(c) Support for a multiple PLC system of the QCPU

To access a multiple PLC system of the QCPU using the "read/write data exchange in the PLC CPU" function of the QE71, access should be made to the control PLC of the network module/Ethernet interface module that has received a communication request message of the QCPU station.

* Access can be made to the control PLC with either the E71 or QE71 command.

2 Access to the MELSECNET/H Remote I/O station

(a) Available exchange functions of the QE71

- Read/write data exchange in the PLC CPU
- Router relay exchange
- MELSECNET/10 relay exchange

(b) Available command

① The following accesses can be performed using the QE71 command.

Available function	Function
Read/write device memory	Batch reading, batch writing
	Random reading, testing (random writing)
	Monitor data registration, monitoring
	Batch reading of multiple blocks, batch writing of multiple blocks
Read/write buffer memory	Reading/writing from/to the buffer memory of the Ethernet interface module
Read/write buffer memory of intelligent function module	Reading/writing from/to the buffer memory of the specified intelligent function module

② The following devices of a remote I/O station can be accessed using the read/write device memory function.

Device	Device type		Device code		Device number range	Expression		Remark
	Bit	Word	For ASCII	For binary		Decimal	Hexadecimal	
			code	code				
Special relay	○		SM	91H	000000 to 002047	○		Assignment cannot be changed.
Special register		○	SD	A9H	000000 to 002047	○		
Input relay	○		X*	9CH	000000 to 001FFF		○	
Output relay	○		Y*	9DH	000000 to 001FFF		○	
Internal relay	○		M*	90H	000000 to 008191	○		
Link relay	○		B*	A0H	000000 to 003FFF		○	
Data register		○	D*	A8H	000000 to 012287	○		
Link register		○	W*	B4H	000000 to 003FFF		○	
Link special relay	○		SB	A1H	000000 to 0001FF		○	
Link special register		○	SW	B5H	000000 to 0001FF		○	

3 Transmission delay time via the network

For details on the transmission delay time via the network (MELSECNET/H, MELSECNET/10) when accessing the QCPU of other station, refer to the explanation on the "Transmission Delay Time of the Instruction Communication" in the reference manual of the network system to be routed.

4 Support for the MELSECNET/10 relay exchange function of the QE71

By using the MELSECNET/10 relay exchange function of the QE71, the following types of accesses to other station can be performed via MELSECNET/H (MELSECNET/10 mode):

- Read/write data exchange in the PLC CPU
- Data link command exchange

Replace the target MELSECNET/H (MELSECNET/10 mode) with the MELSECNET/10 in the explanation of this document.

2.5 Precautions for Network System Configuration

This section describes the precautions for the network system configuration using the QE71.

2.5.1 Precautions for the Selection of the QE71

1

Communication frames when sending/receiving data to/from a remote node

- (a) The QE71 can communicate with a remote node that handles frames of which the Ethernet header for the data link layer is in accordance with the Ethernet standard.

It cannot communicate with a remote node that handles frames of which the Ethernet header is in accordance with the IEEE802.3 standard.

This restriction is due to the differences in the types and lengths used in these Ethernet headers. (Refer to Item 8 in Appendix.)

- (b) As one method to confirm whether communication can be performed with the QE71 from a remote node, send the "Ping command" to a QE71 in which initial processing has normally been completed. If a reply is returned from the QE71 to the remote node, it means that the communication frame is compatible.

*The status of the QE71 in which initial processing has normally been completed:
The RDY LED flashes and X19 is ON.

**"Ping command": ICMP's echo request/echo reply function

2

Communication with remote nodes

- (a) The QE71 can send/receive data to/from a remote node that can support the TCP/IP or UDP/IP communication protocol.
- (b) A node, which is performing a normal communication using the "Ping command" mentioned above via the TCP/IP or UDP/IP communication protocol, can communicate with the QE71.

2.5.2 Precautions for the System Design

1 Installation of equipment

- (a) The installation distances between devices and the segment lengths must be within the specification value ranges.
- (b) For the installation of the 10BASE5, 10BASE2 and 10BASE-T, we recommend that each customer contact a professional contractor/cable manufacturer.

2 Separating the communication lines

To prevent communication problems that may be caused by excessive messages being transmitted over the communication line (congestion), do not allow unwanted messages to be transmitted over the communication line as much as possible.

Some examples of preventing communication line congestion are as follows:

- (a) Using a switching hub, gateway or router, separate the communication line for control and the communication line for transmission/reception of general data and office information.
- (b) Using a switching hub, gateway or router, separate the communication line to which a personal computer is connected (segment) and the communication line to which a computer for process control and a QE71 are connected (segment), so that no data other than communication messages between connected devices can be transmitted over other lines (segments).

3 Checking normal operation in the communication counterpart's remote node

The following examples show how to check the status on the remote node side to prevent communication from being disabled due to the occurrence of a sudden problem (down) on the remote node side with which communication is being performed in the communication between devices.

- (a) Using the QE71's existence check function
This function sends the "Ping command" from the QE71.
For more details, refer to *2 at the end of Item 5.2.2.

- (b) Duplex connection

By providing a separate connection for checking the status of the remote node side, the status of the local station can be periodically notified to the remote node side. (The status information of the self node is exchanged using a separate connection.)

* In this status check, change all connections with the applicable device from "closed" to "open" when an abnormality is detected on the remote node side.

4 Restarting the communication system

When designing a system, implement a feature to restart the communication system quickly with which a communication error can be notified to the maintenance personnel by the use of lamp display or buzzer sound in case the communication between devices is disabled due to a device failure or line problem.

2.5.3 Precautions for Accessing the QnACPU

1 Available functions

The following table shows the available functions, and the dates of manufacturing as well as the versions that support these functions.

Function	PLC CPU		
	Q2ACPU Q3ACPU Q4ACPU	Q2ASCPU Q2ASHCPU	Q4ARCPU
Batch read/write of multiple blocks			All products can be used.
Data link command exchange	Products whose date of manufacturing is 9707B or later can be used.		All products cannot be used.
MELSECNET/10 relay exchange			
Connection of GPPW to QE71 (Ethernet connection)			(*2)
Access to remote PLC from MELSOFT product via QE71 (*1)			

*1 Access to a remote PLC can be performed via the QE71 depending on the product.

For more details, refer to the manual of each product.

GPPW: SW2D5C/F-GPPW-E or later

MX Component: SW0D5C-ACT-E or later

*2 These functions can be used for the Q4ARCPU for which function addition has been implemented if its date of manufacturing begins with "0012" (last two digits of the year + two-digit month) and the software version is B or later.

GPPW can set up the parameters necessary to use these functions if its version is 6.05F or later.

For an overview, see Item 4.8. For more details, refer to the manual of each product.

Also, refer to the user's manual of the Q4ARCPU for which function addition has been implemented (IB-66686-B or later products).

2 Support of redundant Q4ARCPU systems

① The QE71 does not support redundant Q4ARCPU systems.

② When using a QE71 in a redundant Q4ARCPU system, the available functions will be limited to those when the QE71 is used with the Q4ACPU. *3
The operation status of each Q4ARCPU (control system, standby system) in a redundant system can be checked with the SM1516 special relay.

*3 When using the AJ71QE71 or AJ71QE71-B5 on the main base units of a redundant system, use products of software version "D" or earlier in both systems, or use products of software version "E" or later in both systems.

3. SPECIFICATIONS

This section explains the QE71 general specifications, performance specifications, and transmission specifications.

3.1 General Specifications

This section explains the QE71 general specifications.

Table 3.1 General Specifications

Item	Specifications				
Usage environment temperature	0 to 55°C				
Storage environment temperature	-20 to 75°C				
Usage environment humidity	10 to 90%RH, No condensation formation				
Storage environment humidity	10 to 90%RH, No condensation formation				
Anti-vibration	Conforming to JIS B 3502, IEC 61131-2	When there is intermittent vibration			Sweep frequency 10 times each in X,Y,Z directions (for 80 min.)
		Frequency	Acceleration	Amplitude	
		10 to 57Hz	—	0.075mm	
		57 to 150Hz	9.8m/s ²	—	
		When there is continuous vibration			
		10 to 57Hz	—	0.035mm	
57 to 150Hz	4.9m/s ²	—			
Anti-shock	Conforming to JIS B 3502, IEC 61131-2 (147m/s ² , 3 times in each of 3 directions X,Y,Z)				
Usage environment	No corrosive gas, etc.				
Usage altitude *3	2,000m or less				
Installation location	Inside the control panel				
Over voltage category *1	II or less				
Pollution level *2	2 or less				

*1 Shows if an estimate has been made for which distribution areas the connections will be done for the device from the public power grid to the device installation area inside the configuration.

Category II applies to equipment that receives its power from fixed facilities. The surge resistance voltage for equipment rated to 300V is 2,500V.

*2 Shows the index for inductive matter generation in the environment in which the equipment is used. Pollution level 2 is when only non-conductive pollution occurs. A temporary conductivity caused by condensation must be expected occasionally.

*3 Do not use or store the PLC under pressure higher than the atmospheric pressure of altitude 0m. Doing so can cause a malfunction.

When using the PLC under pressure, please contact your sales representative.

3.2 Performance Specifications

This section explains the performance specifications of the QE71.

Table 3.2 Performance Specifications

Item		Specifications			
		AJ71QE71N3-T A1SJ71QE71N3-T	AJ71QE71N-T A1SJ71QE71N-T	AJ71QE71N-B5 A1SJ71QE71N-B5	AJ71QE71N-B2 A1SJ71QE71N-B2
		10BASE-T		10BASE5	10BASE2
Transmission specifications	Data transmission speed	10Mbps			
	Communication mode	Half-duplex			
	Transmission method	Base band			
	Maximum distance between nodes	—	2500 m (8202.10 ft.)	925 m (3034.77 ft.)	
	Maximum segment length	100 m (328.08 ft.) (*1)		500 m (1640.42 ft.)	185 m (606.96 ft.)
	Maximum number of nodes/connection	Cascade connection, up to 4 stages		100 units/segment	30 units/segment
	Minimum node interval	—	2.5 m (8.20 ft.)	0.5 m (1.64 ft.)	
Transmission and reception data storage memory	Number of allowable simultaneously open connections	8 connections (Connections that can be used by sequence programs)			
	Fixed buffer	1K words × 8			
	Random access buffer	6K words × 1			
Number of remote nodes that can be communicated in a single initial processing		No restrictions			
EEPROM write frequency		Maximum of 10,000 times in the same area			
Number of occupied I/O points		32 points/1 slot (I/O assignment: special 32 points)			
5 VDC internal current consumption		AJ71QE71N3-T : 0.53A A1SJ71QE71N3-T: 0.53A	AJ71QE71N-T : 0.40A A1SJ71QE71N-T: 0.40A	AJ71QE71N-B5 : 0.40A A1SJ71QE71N-B5: 0.40A	AJ71QE71N-B2 : 0.56A A1SJ71QE71N-B2: 0.53A
Connector		Modular jack (RJ45)		D-sub connector (male 15 pins)	BNC connector
Connection cable		Unshielded twisted pair cable (UTP), or shielded twisted pair cable (STP) rated in category 3, 4 or 5	Unshielded twisted pair cable (UTP) rated in category 3, 4 or 5	AUI cable (twisted pair cable)	Coaxial cable (RG58A/U or RG58C/U)
12 VDC external power supply capacity (for transceiver)		—		(*2)	—
External dimensions		AJ71QE71N3-T, AJ71QE71N-T, AJ71QE71N-B5, AJ71QE71N-B2 : 250 (9.84) (H) × 37.5 (1.48) (W) × 106 (4.17) (D) [mm(in.)] A1SJ71QE71N3-T, A1SJ71QE71N-T, A1SJ71QE71N-B5, A1SJ71QE71N-B2 : 130 (5.12) (H) × 34.5 (1.36) (W) × 94 (3.70) (D) [mm(in.)] •All do not include the protruded section on the front surface.			
Weight		AJ71QE71N3-T : 0.30 kg (0.66lb.) A1SJ71QE71N3-T: 0.18 kg (0.37lb.)	AJ71QE71N-T : 0.30 kg (0.66lb.) A1SJ71QE71N-T: 0.17 kg (0.37lb.)	AJ71QE71N-B5 : 0.33kg (0.73lb.) A1SJ71QE71N-B5 : 0.19kg (0.42lb.)	AJ71QE71N-B2 : 0.35kg (0.77lb.) A1SJ71QE71N-B2 : 0.20kg (0.44lb.)

*1 The length between the hub and a node.

*2 It is necessary to use a power supply that satisfies the specifications of both the transceiver and AUI cable. (Refer to Section 2.3.)

Use the AJ71QE71N-B5 in consideration of the voltage drop (maximum 0.8V) of the AJ71QE71N-B5 module.

Remarks

The distances between nodes and the segment lengths are shown in the figures below.
10BASE5, 10BASE2
10BASE-T

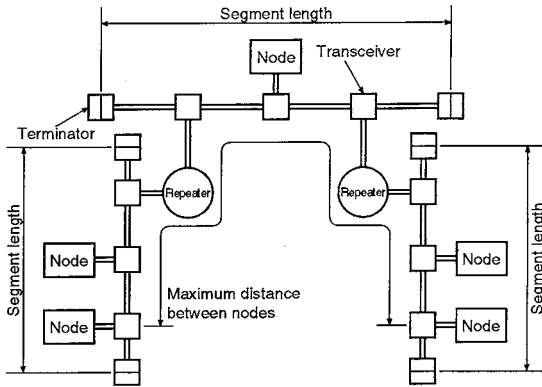

Up to 4 stages of cascade connection can be used.

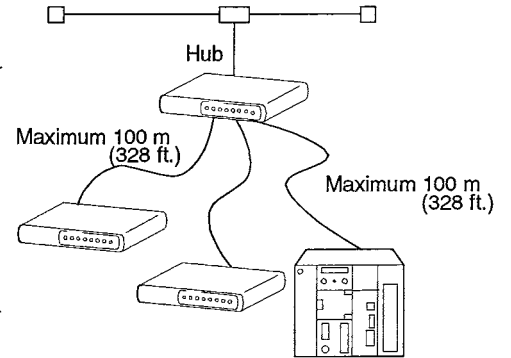

3.3 Data Codes During Exchange

This section explains the data codes used when exchanging between the QE71 and remote node or PLC CPU.

1 The data codes used during exchange are given below.

① Between QE71 and the remote node

The data exchange function makes it possible to conduct exchange by selecting either binary code or ASCII code as shown in the table below.

Switching between binary code and ASCII code is done using the exchange condition setting switch (SW2: Data code setting) on the QE71.

(For details refer to Item 4.3.2)

○ : Selection possible
 × : Not possible

Table 3.3 Codes that can be selected (*1)

Data exchange function		Binary code	ASCII code	Function explanation item
Fixed buffer exchange	With procedure	○	○	Chapter 6
	Without procedure	○	× (*3)	Chapter 7
Random access buffer exchange		○	○	Chapter 8
Reading/writing data in the PLC CPU (General data exchange)		○	○	Chapter 9 Chapter 10
File transmission (FTP server function)		(*2)		Chapter 13
Data link command exchange		○	× (*3)	Chapter 14
MELSECNET/10 relay exchange		○	× (*3)	Chapter 15

*1 When using automatically opened UDP/IP Port, the following functions make data exchange possible, but in all of the cases, exchange using ASCII code is not possible.

Binary code is always used regardless of the QE71 exchange condition setting switch (SW2: Data code setting) setting.

- ① Reading/writing data in the PLC CPU
- ② Data link command exchange
- ③ MELSECNET/10 relay exchange

*2 It is possible to switch between binary code and ASCII code using the FTP server function, but whether the data is handled in 1 byte units or line units depends on whether the FTP server is ASCII or binary.

The code system of this explanation is a separate issue.

*3 Communication can be performed using the binary codes shown in the figure below:

② Between QE71 and PLC CPU

Received binary code.

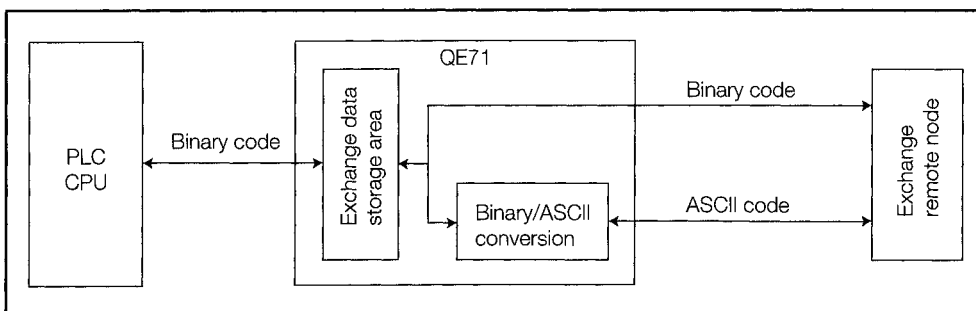
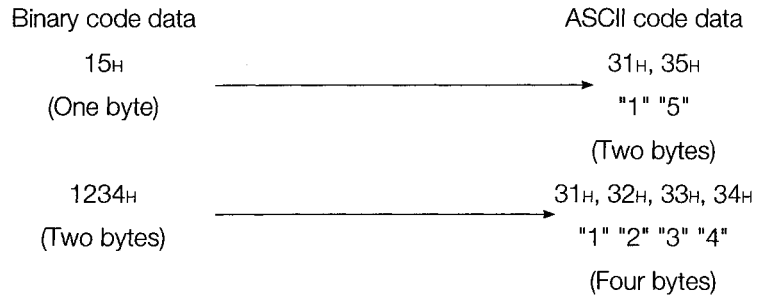

Fig 3.1 Exchange Data Code System

- 2** When exchanging using the ASCII code, the 1 byte binary code data is automatically converted into the 2 byte ASCII code.

Example:



- 3** The amount of data that can be exchanged at one time between the QE71 and remote node depends on the function used and the data code setting (binary/ASCII) selected using the exchange condition setting switch (SW2 : Data code setting) on the QE71.

The following table shows the maximum amount of exchange data that can be sent at one time for each data exchange function.

Table 3.4 Exchangeable Data Amount

Data exchange function		Exchangeable data size
Fixed buffer exchange	With procedure	1017 words (binary code), 508 words (ASCII code)
	Without procedure	2046 bytes
Random access buffer exchange		1017 words (binary code), 508 words (ASCII code)
Reading/writing data in the PLC CPU (General data exchange)		Equivalent to the maximum number of points that can be specified by each command/instruction: Maximum 1920 bytes
File transfer (FTP server functions)		Maximum 1 file
Data link command exchange		Equivalent to the maximum number of points that can be specified by each command/instruction: Maximum 960 bytes
MELSECNET/10 relay exchange		480 words

3.4 Functions

3.4.1 List of Functions

Table 3.5 List of QE71 Functions

Functions	Description of functions	Exchange partner module					
		Remote node ↓ QE71	QE71 ↓ Remote node	QE71 ↓ QE71	QE71 ↓ E71	E71 ↓ QE71	
Fixed buffer exchange	(1) Exchange between the PLC CPU and remote nodes in the Ethernet is done on a 1:1, 1:n basis. When With Procedure is used, exchange is conducted while a handshake is being done with the remote node. (2) When conducting exchange with a remote node, the fixed buffer (one area for each 1k word) has 8 areas (however, please refer to Item 3.3 regarding the amount of data that can be exchanged at one time.) (3) The exchange partner and usage application (transmission/reception) for the fixed buffer is set by the exchange parameters. (4) Exchange can be done with the connection and remote node that is in the Ethernet.	With procedure	○	○	○	○	○
		Without procedure	○	○	○	○	○
Random access buffer exchange	(1) Read/write exchange for the QE71 random access buffer memory can be conducted from multiple nodes. (2) Random access buffer used to exchange with remote nodes is 6k words. A continuous area can be read/written from the PLC and remote nodes. (However, please refer to Item 3.3 regarding the amount of data that can be exchanged at one time.) (3) During random access buffer exchange, the random access buffer can be used as a common buffer memory within the network without specifying the memory area for each connection. (4) Exchange can be done with remote nodes that are ending the connection open processing in the Ethernet.		○	/	×	×	/
Read/write data exchange in the PLC CPU	(1) The data in the PLC CPU such as that for each device, file data, and special function module buffer memories, etc., are read/written in the PLC CPU that is installed in the QE71 using request from the remote node. (2) When the PLC installed in the QE71 is connected to the MELSECNET, the exchange from remote node with the remote station PLC CPU can be done via the MELSECNET. (Please refer to Item 9.1 for details regarding data exchange with remote stations.) (3) Exchange can be done with remote node that is doing connection open processing end in the Ethernet. In addition, if an automatic open UDP/IP Port is used, exchange can be done even if the local PLC CPU is stopped.	QE71 command exchange	○	/	×	×	/
		E71 command exchange	○	/	×	×	/
Data link command exchange	(1) The sequence programs SEND, RECV, READ, WRITE, REQ, ZNRD, ZNWR commands are used to read/write to each device, send and receive data, control the state, and read/write time data for the PLC CPU installed in the QE71. (2) When the PLC installed in the QE71 is connected to the MELSECNET, exchange from the PLC CPU to remote PLC CPU can be done via Ethernet or MELSECNET. (3) Exchange can be done with remote PLC CPU (maximum 8 stations) that is ending connection open processing in the Ethernet.		/	/	○	×	/
Exchange when the PLC CPU is in the STOP status	(1) This function is used for the communication lines for which open processing by the sequence program has been completed. (2) After the open processing has been completed and when the PLC CPU becomes in the STOP status or when the open request signal/initial request signal is turned off, data exchange can be continued from remote nodes to QE71.		/	/	/	/	/

Functions	Description of functions	Exchange partner module				
		Remote node ↓ QE71	QE71 ↓ Remote node	QE71 ↓ QE71	QE71 ↓ E71	E71 ↓ QE71
File transfer	(1) The TCP/IP standard protocols FTP server functions are used to read / write data from the QnACPU file and to read the file list. (2) All files handled by QnACPU, such as parameter, sequence program, and data file, can be accessed using FTP commands. (3) Exchange can be done with the remote node if the initial processing for QE71 has ended.	○	/	×	×	/
Simultaneous broadcast communication	(1) Data exchange by UDP/IP that broadcasts the applicable data simultaneously to all remote nodes on the same Ethernet as the request origin. However, the remote node is required to get rid of reading when the received message by simultaneous broadcast is not necessary. (2) Simultaneous broadcast cannot be done for router relay and MELSECNET/10 relay exchange. (3) Exchange can be done from remote nodes that are ending connection open processing in the Ethernet.	○	○	○	×	/
MELSECNET/10 relay exchange	(1) Conducts data exchange over multiple networks when Ethernet and MELSECNET/10 are mixed in the same network, and when there are multiple relays in the Ethernet. (2) The maximum number of relays is 7 and relays can be done in the QE71 and QLP21/QBR11. (Relays between each network with the same user specified network No. and address as that of the MELSECNET/10) (3) Exchange can be done with the remote node if the initial processing for QE71 has ended.	○	/	○	×	/
Router relay exchange	(1) Exchanges data via the routers that are connected in the Ethernet network system. (QE71 does not operate as a router.) (2) Exchange is possible via a router by data transmission after TCP's active open and UDP open. (3) Exchange can be done with the remote node that is ending the connection open processing in the Ethernet.	○	○	○	○	/
Existence check	(1) Checks if the partner node is operating correctly when exchange has not been done with the partner node for a specified period of time after connection open processing has ended. (2) Closes the line (connection forced disconnect) if the QE71 exchange condition setting switch (SW1) is off when the partner node is not operating correctly.	○	○	○	○	/
EEPROM registration	(1) Stores the data exchange setting values (parameters) that are registered in the EEPROM built into the QE71 in the buffer memory as the default values when the QE71 is booted up. (2) Conducts the above registration to the EEPROM when the request is received from the sequence program or the remote node.	○	/	/	/	/
Exchanged error storage	(1) Stores a maximum of 16 sets of error history information, such as message subheaders and partner node IP address, in the buffer memory when a data exchange error occurs. (2) This error history information makes it easy to analyze the cause of data exchange trouble.	/	/	/	/	/
Self-loopback test	(1) Conducts a hardware check including QE71 transmission and reception circuits.	/	/	/	/	/

○ : Executable × : Not executable

3.4.2 Relationship between Communication Remote Node and Added Functions for Each Communication Function

Shows what partner equipment can be exchanged with and what added functions can be used for each exchange function.

Table 3.6 Relation between Exchange Partner Nodes and Added Functions

Exchange functions		Exchange partner			Communication format		Added functions					
		Remote node	E71	QE71	TCP/IP	UDP/IP	Simultaneous broadcast	MELSECNET /10 relay exchange	Pairing exchange	Existence check	Exchange with automatic open UDP port	Exchange when the PLC CPU is in the STOP status
Fixed buffer exchange	With procedure	○	○	○	○	○	×	×	○	○	×	×
	Without procedure	○	○	○	○	○	○ (*1)	×	○	○	×	×
Random access buffer exchange		○	×	×	○	○	×	×	×	○	×	×
Read/write data exchange in the PLC CPU	QE71 command exchange	○	×	×	○	○	○ (*1)	○	×	○ (*3)	○	○
	E71 command exchange	○	×	×	○	○	×	×	×	○	×	○
Data link command exchange		×	×	○	×	○	○ (*1)	○	×	×	○	○
File transfer (FTP server function)		○	×	×	×	○	×	×	×	×	×	○
Router relay exchange (router relay functions)		○	○	○	○	○	○ (*2)	×	—	—	—	○

○ : Usable × : Unusable — : None

*1 Only valid during UDP.

*2 Data is broadcast simultaneously after it is transmitted to the router and when it reaches the designated network. (UDP/IP)

*3 Only valid with nodes opened by the sequence program.

3.5 Send and Receive Processing

3.5.1 Message Division and Data Length

The message exchanged between the QE71 and the remote node is sometimes allocated by the local node or remote node transmission/reception buffer capacity.

Below is shown the message data length when it is allocated and transmitted or received.

* Reception data determination method

Messages received on the same connection are subject to the following subheader and data length determinations to determine the processing to be used.

- Subheader : This is used to determine whether the message is used to perform fixed buffer exchange, random access buffer exchange, or data read/write exchange in the PLC CPU.
- Data length : This is used to determine the number of remaining data.

1 When the QE71 receives data the message is reconstructed using the following data link (hereafter internal data length) when the message is reconstructed from the TCP/UDP level.

- ① Data length in the data bearing fixed buffer exchange or random access buffer exchange.
- ② The data length calculated from the command message contents when data is read or written in the PLC CPU.

2 The QE71 performs the following processing when the internal data length and the data amount that is actually transmitted differ.

- ① When the transmitted amount is less
 - Waits until the remaining data is transmitted.
 - If the next data is not sent within the response monitoring timer value (Item 5.2.2) the message currently being received will be ignored and the next processing (receive rate form initial message) will begin.
- ② When the transmitted data amount is more
 - Determined to be a transmission with two or more messages linked together.
 - The data from the first data received until the internal data length is handled as the initial message and that coming immediately thereafter is handled as the next message. (An error will be generated if there is subheader analysis being conducted or if processing is being conducted for the second message or thereafter.)

(Example) Message transmitted has one message from the partner node



Determined as a message by the QE71

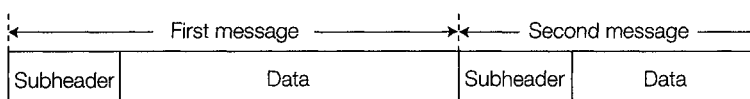

This portion is actually not a subheader so a command/response undefined error occurs.

Remarks

(1) If the error mentioned in **2** above is generated, an error code is stored for one of the error information storage areas shown below in the QE71 buffer memory.

- Exchange state storage area
- Error log area

3.5.2 Continuous Processing Over the Same Connection

The following explains the procedure to transmit data between QE71 and other nodes over the same connection, and the QE71 processing when continuous data transmission is performed from other nodes to the QE71 over the same connection.

1

Procedure to transmit data between other nodes and QE71

When transmitting data between other nodes and QE71, perform data transmission after the processing for the previous data transmission is complete.

For example, when data transmissions accompany responses, the next data transmission should be commenced after the response to the previous transmission is received.

* If data transmission is continued without following the above procedure, an error may be generated on the QE71 side, the connection may be closed, or the open error detection signal (X18) may turn on.

2

The QE71 processing during continuous data transmission is performed from other nodes to QE71

The following explains the QE71 processing when it receives a new message that has no relationship to the current processing, which is the processing of the message received previously over the same connection.

- (a) The processing of the message received first is performed.
- (b) After the processing of the message received first is complete, the processing of the next message will be commenced. (The processing of the next message will be suspended.)

Example: When a random access buffer read request is received via connection 1 while the receive processing for fixed buffer exchange is in progress

- ① The receive processing for the fixed buffer exchange is continued (*1).
- ② After the receive processing for the fixed buffer exchange is completed, the processing for random access buffer read is executed.

*1 The "receive processing for fixed buffer exchange in progress" is defined as the period of time from when the receive end signal (X0) turns on until the receive end confirmation signal (Y0) turns off.

3.5.3 Conditions for Issuing a Forced Disconnect

When the following conditions occur with the TCP/IP communication, the QE71 sends a connection forced disconnect to the remote node to forcefully close the line. (ABORT (RST) command transmission)

- ① When the initial request signal is turned off in the state that the open processing has ended on the connection used.
- ② When the remaining messages are not received within the response monitoring time when data allocation is being received.
- ③ TCP transmission error occurs when OFF (close) is selected using the exchange condition setting switch (SW1 : line processing selection during TCP time out error).
- ④ When an existence check trouble is detected for the existence check connection.
- ⑤ When an open request is performed again from the remote node side to the QE71 port that either active or full-passive open for performing TCP/IP communication has normally been ended. Or when an open request is performed using the same port number again from the identical remote node to the QE71 port that Unpassive open has normally been ended.

3.6 I/O Signals for the PLC CPU

This section explains the QE71 I/O signals.

The I/O signal allocation shows that the QE71 is installed in the 0 slot of the basic base units. It means that device X receives an input signal from the QE71 to the PLC CPU and that device Y receives an output signal from the PLC CPU to the QE71.

3.6.1 List of I/O Signals

Table 3.7 List of I/O Signals for the PLC CPU

Signal direction QE71 to PLC CPU			Signal direction PLC CPU to QE71		
Device No.	Signal name		Device No.	Signal name	
X0	Transmission normal end signal or reception end signal	For connection 1's fixed buffer exchange	Y0	Connection number 1	Transmission request signal and reception end check signal
X1	Transmission error detection signal or reception error detection signal		Y1	Connection number 2	
X2	Transmission normal end signal or reception end signal	For connection 2's fixed buffer exchange	Y2	Connection number 3	
X3	Transmission error detection signal or reception error detection signal		Y3	Connection number 4	
X4	Transmission normal end signal or reception end signal	For connection 3's fixed buffer exchange	Y4	Connection number 5	
X5	Transmission error detection signal or reception error detection signal		Y5	Connection number 6	
X6	Transmission normal end signal or reception end signal	For connection 4's fixed buffer exchange	Y6	Connection number 7	
X7	Transmission error detection signal or reception error detection signal		Y7	Connection number 8	
X8	Transmission normal end signal or reception end signal	For connection 5's fixed buffer exchange	Y8	Connection number 1	Open request signal
X9	Transmission error detection signal or reception error detection signal		Y9	Connection number 2	
XA	Transmission normal end signal or reception end signal	For connection 6's fixed buffer exchange	YA	Connection number 3	
XB	Transmission error detection signal or reception error detection signal		YB	Connection number 4	
XC	Transmission normal end signal or reception end signal	For connection 7's fixed buffer exchange	YC	Connection number 5	
XD	Transmission error detection signal or reception error detection signal		YD	Connection number 6	
XE	Transmission normal end signal or reception end signal	For connection 8's fixed buffer exchange	YE	Connection number 7	
XF	Transmission error detection signal or reception error detection signal		YF	Connection number 8	
X10	Connection number 1	Open end signal	Y10	EEPROM read request signal	
X11	Connection number 2		Y11	EEPROM write request signal	
X12	Connection number 3		Y12	Usage prohibited	
X13	Connection number 4		Y13		
X14	Connection number 5		Y14		
X15	Connection number 6		Y15		
X16	Connection number 7		Y16		
X17	Connection number 8		Y17	COM.ERR LED turn off request signal	
X18	Open error detection signal	Y18	Usage prohibited		
X19	Initial normal end signal	Y19	Initial request signal		
X1A	Initial error detection signal	Y1A	Usage prohibited		
X1B	Usage prohibited	Y1B			
X1C	COM.ERR LED turned on signal	Y1C			
X1D	EEPROM read end signal	Y1D			
X1E	EEPROM write end signal	Y1E			
X1F	Watchdog timer error detection signal	Y1F			

Important

- (1) Among the I/O signals for the PLC CPU, do not output (ON) the signals that are "usage prohibited." If any output is performed with respect to "usage prohibited" signals, it may result in the malfunction of the PLC system.
- (2) To perform each processing shown in Chapter 5 and succeeding sections, be sure to check the ON/OFF timing of the output signal (Y) and the input signal (X) shown in the applicable explanatory items, and then perform output relative to the output signal.
If ON/OFF of the output signal has not been performed according to the procedure shown in the applicable explanatory items, the QE71 will not be able to operate normally.

3.6.2 Detailed Explanation of I/O Signals

This section explains about the I/O signals ON/OFF timing and conditions shown in Table 3.7 (on the previous page). The codes in the parentheses are the device numbers that correspond to Table 3.7.

1 Transmission normal end signal and reception normal end signal (X0, X2, X4, X6, X8, XA, XC, XE)

These signals are used when exchange is conducted with the fixed buffer. These signals are not used when exchanging with the random access buffer or when reading and writing data in the PLC CPU. Used as the transmit normal end signal when the appropriate fixed buffer transmission is used. Used as the reception end signal when the appropriate fixed buffer reception is used.

(a) When used as transmission end signal

When exchanging with procedure

- ① Data is transmitted when the transmission request signal (Y0 to Y7) is turned on.
- ② The remote node that has received the data returns a response to the QE71.
- ③ The transmit normal end signal is turned on when a response is returned by the remote node.
- ④ The transmit normal end signal is turned off when the transmit request signal (Y0 to Y7) is turned off.
- ⑤ The transmission normal end signal is not turned on when the end code returned from the remote node is anything other than 00H. The transmission error detection signal (X1, X3, X5, X7, X9, XB, XD, XF) is turned off.

When exchanging without procedure

- ① Data is transmitted when the transmission request signal (Y0 to Y7) is turned on.
- ② The transmission normal end signal is turned on when the data transmission from the QE71 is completed.
- ③ The transmission normal end signal is turned off when the transmission request signal (Y0 to Y7) is turned off.
- ④ The transmission normal end signal is not turned on when a transmission error is generated. The transmission error detection signal (X1, X3, X5, X7, X9, XB, XD, XF) is turned on.

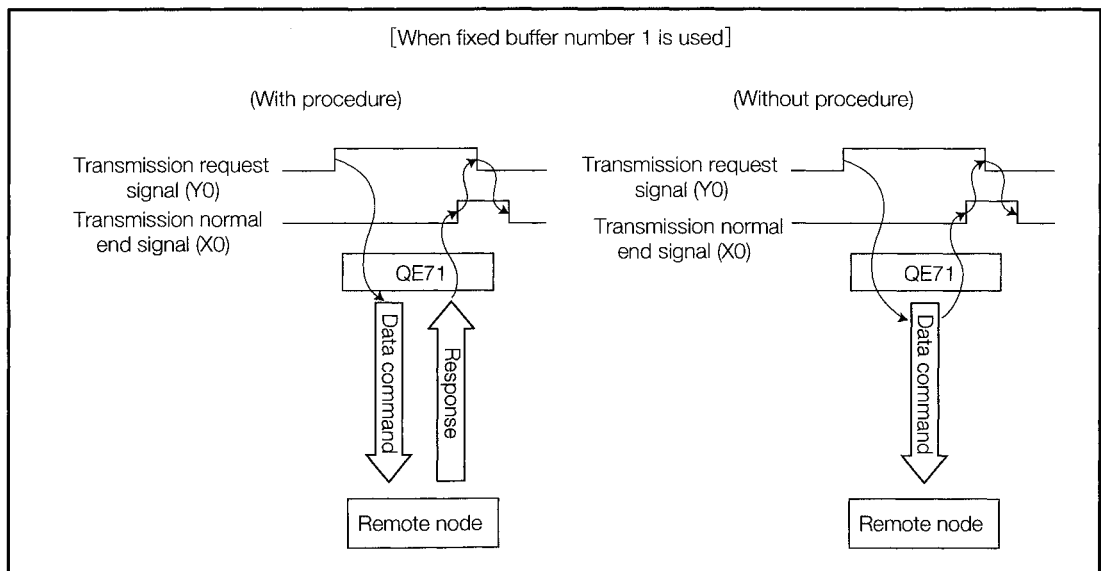

(b) When used as reception end signal

When exchanging with procedure

- ① Turns on when the QE71 receives data from a remote node.
- ② Can be used as the handshake signal when reception data is read from the PLC CPU using the FROM command, etc.
- ③ The reception end check signal (Y0 to Y7) is turned on after the reception data is read using the FROM command, etc.

A response is returned to the remote node that transmitted the data.

- ④ Reception end signal is automatically turned off after a response is sent to the remote node.
- ⑤ The reception end signal is not turned on when problem data is sent from the remote node.

When exchanging without procedure

- ① Turns on when the QE71 receives data from a remote node.
- ② Can be used as the handshake signal when the received data is read from the PLC CPU using a FROM command, etc.
- ③ The receive end check signal (Y0 to Y7) is turned on after the receive data is read using the FROM command, etc.
- ④ The receive end signal is automatically turned off when the receive end check signal is turned on.
- ⑤ The receive end signal is not turned on when following data is transmitted from a remote node.

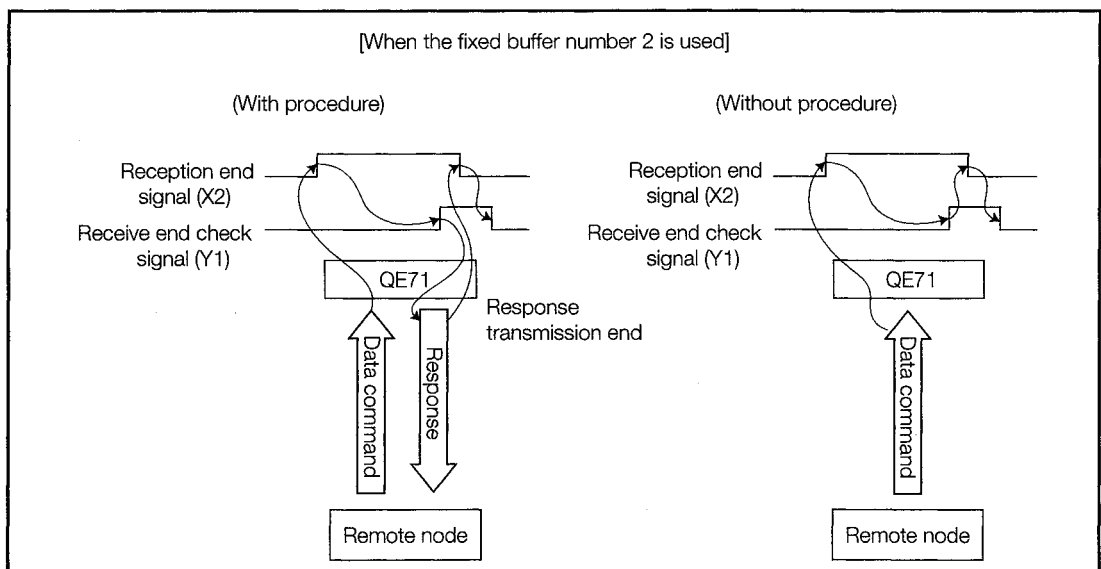

2**Transmission error detection signal or reception error detection signal
(X1, X3, X5, X7, X9, XB, XD, XF)**

This signal is used when fixed buffer exchange is performed. This signal is not used for random access buffer exchange or exchange when reading or writing of data inside the PLC CPU is conducted.

When an applicable fixed buffer is used for transmission, use it as a transmission error detection signal.

When an applicable fixed buffer is used for reception, use it as a reception error detection signal.

(a) When used as the transmission error detection signal

When exchanging with procedure

- (1) The transmit error detection signal is turned on when the response from the remote node is not returned within the response monitor time (Refer to Item 5.2.2) after data is transmitted from the fixed buffer.
- (2) The transmission error detection signal is turned on when the specified retry processing (Refer to Item 5.2.2.) is conducted when the "ACK" is not returned after data is sent from the fixed buffer that is using the TCP connection. (Retry processing is not performed for UDP)
- (3) The transmission error detection signal is turned on when the finish code response received from the remote node is anything other than 00H after data has been transmitted from the fixed buffer.
- (4) When the transmission error detection signal is turned on, the error contents can be checked by reading the fixed buffer transmission error code storage area (buffer memory 125, 135, ...195).
- (5) The transmission error detection signal is turned off when the fixed buffer transmission request signal (Y0 to Y7) is turned off.

When exchanging without procedure

- (1) The transmission error detection signal is turned on when the specified retry processing (Refer to Item 5.2.2) is performed when the "ACK" is not returned after the data has been transmitted from the fixed buffer using the TCP connection (Retry processing is not performed for UDP.)
- (2) When the transmission error detection signal is turned on, the error contents can be checked by reading the fixed buffer transmission error code storage area (buffer memory 125, 135, ...195).
- (3) The transmission error detection signal is turned off when the fixed buffer transmission request signal (Y0 to Y7) is turned off.

(b) When used as the reception error detection signal

- (1) When close processing is performed for the corresponding connection upon receiving Close/Abort (RST) from the partner remote node before the completion of the previous data reception processing, the reception error detection signal may turn on.
- (2) When Close/Abort (RST) is received from the partner remote node after the completion of data reception processing, the reception error detection signal does not turn on.
- (3) If the reception error detection signal is on when close processing is performed for the corresponding connection according to (1) above, turn off the open request signal (Y8 to YF) after turning off the reception completion confirmation signal at the timing shown in Remarks in **2** of Item 5.5.3.

3 Open end signal (X10 to X17)

- (a) When the connection open request signal (Y8 to YF) is turned on by the sequence program the exchange parameters are checked and open processing is executed. Here if open processing is performed normally the open end signal (X10 to X17) is turned on.
- (b) When the open request signal is turned on and open processing is not performed normally the open error detection signal (X18) is turned on. (In this case the open end signal is not turned on.)
- (c) Only data can be exchanged with the remote node for which the open end signal (X10 to X17) is turned on (fixed buffer exchange, random access buffer exchange, and reading and writing from the PLC CPU exchange).
- (d) The open end signal (X10 to X17) ON/OFF can be checked using the LED display (BUF1 to BUF8) on the front of the QE71.
- (e) The open end signal (X10 to X17) is turned off when the open request signal is turned off by the sequence program. In the following case the open end signal (X10 to X17) is not turned off. (Refer to Item 5.5.3)
 - ① When an error is generated.
 - ② When CLOSE or ABORT (RST) commands are received from the exchange remote node.
 - ③ When a response monitor timer error occurs.
 - ④ When an error occurs with an existence check function.

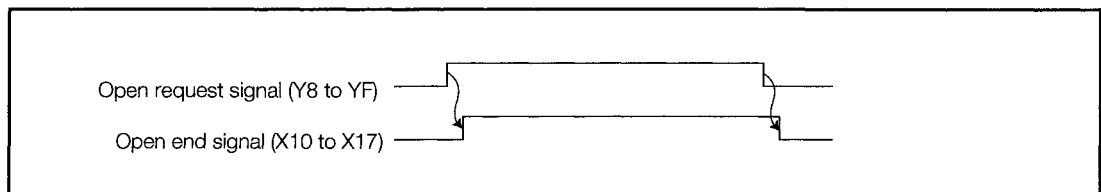
**4 Open error detection signal (X18)**

- (a) When the connection open request signal (Y8 to YF) is turned on by the sequence program the exchange parameters are checked and if an error is detected the open error detection signal is turned on.
- (b) The open error detection signal is turned on when the open request signal (Y8 to YF) is turned on and open processing is not performed normally.
- (c) The open error detection signal is turned on when the TCP or ULP time-out error is generated when the QE71's exchange condition setting switch (SW1: line processing selection during TCP time-out error) is turned off (close).
- (d) When the open error detection signal is on the error contents of the connection for which an error has occurred can be checked by reading the error codes such as open error code storage area (buffer memory 124, 134, ...194) or the error log lock in the exchange state storage area.
- (e) The open error detection signal (X18) is turned off when the open request signal (Y8 to YF) is turned off for the connection for which the open error is occurring.
- (f) When there are multiple open errors the open error detection signal (X18) will not turn off unless all of the corresponding open request signals are turned off.

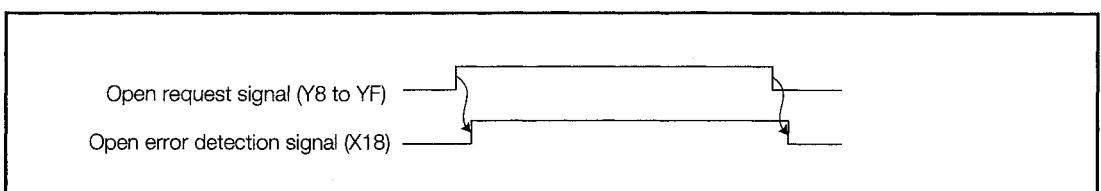

5 Initial normal end signal (X19)

- (a) When the initial request signal (Y19) is turned on by the sequence program the initial parameters are checked and initial processing is executed. Here if initial processing is conducted normally the initial normal end signal (X19) is turned on.
- (b) If the initial processing is not conducted normally the initial error detection signal (X1A) is turned on. (In this case the initial normal end signal (X19) is not turned on.)
- (c) When the installed station is reset by turning on the QE71's exchange condition setting switch (SW3: automatic start mode setting), initial processing is executed following the contents registered in QE71's EEPROM. At this time, initial normal end signal is turned on when the initial processing ends normally.

6 Initial error detection signal (X1A)

- (a) The initial error detection signal (X1A) is turned on and the initial request signal (Y19) is on and initial processing does not end normally.
- (b) The initial error detection signal turns on when a hardware error occurs after initial processing ends normally. (The initial normal end signal is turned off.)
- (c) When the initial error detection signal (X1A) is turned on, the error contents can be checked by reading the exchange state storage area's initial error code storage area (Refer to Item 5.6.1 buffer memory 105).
- (d) The initial error detection signal (X1A) is turned off when the initial request signal is turned off.
- (e) When the installed station is reset by turning on the QE71's exchange condition setting switch (SW3: autonomic start mode setting), initial processing is executed following the contents registered in the EEPROM in the QE71. At this time, if there is a EEPROM error or a registered contents error, the initial error detection signal will be turned on. The error details can be checked by reading the buffer memory exchange state storage shown below.

- Initial parameters error storage area (buffer memory 105)
- EEPROM registration state storage area (buffer memory 112)

* When checking the registered contents of the EEPROM please follow the explanation in Item 4.9.2.

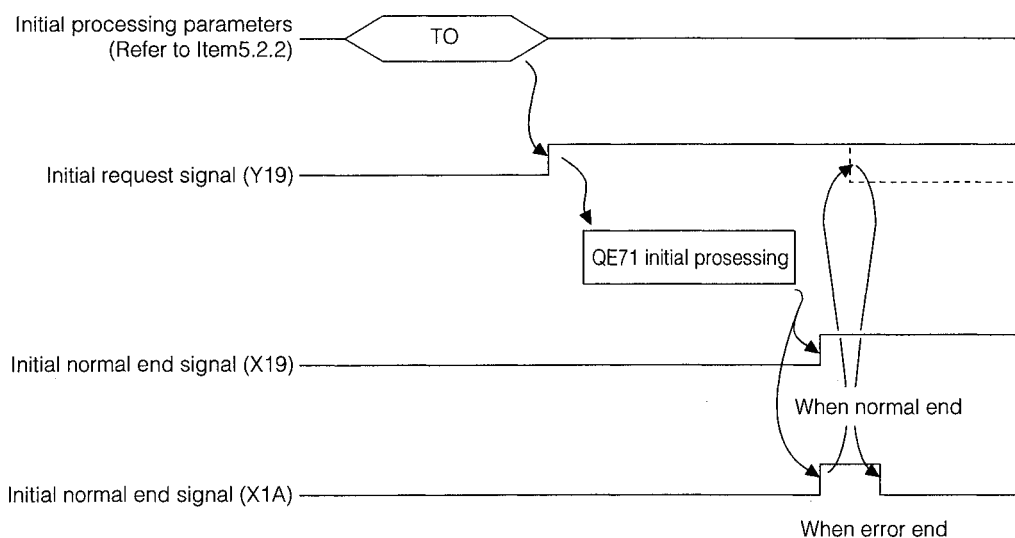

7 COM.ERR LED turned on signal (X1C)

- (a) The COM.ERR LED turned on signal (X1C) is turned on when the QE71 main module's COM.ERR LED is turned on when and exchange error occurs with a remote node. (Refer to Item 17.2 *1)
- (b) The COM.ERR LED turned on signal (X1C) is turned off when the COM.ERR LED turn off request signal (Y17) is turned on. (COM. ERR. LED is turned off.)

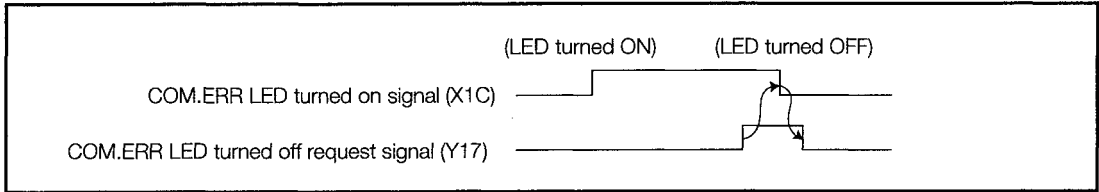

8 EEPROM read end signal (X1D)

- (a) The EEPROM read end signal (X1D) is turned on after the data registered in the EEPROM in the QE71 is read when the EEPROM read request signal (Y10) is turned on.
- (b) Whether the read was normal end or error end can be checked by reading the EEPROM read results storage area (buffer memory 114) of the buffer memory exchange state storage area. (Normal end if the storage value is 0 and the error end if the storage is anything other than 0.)
- (c) When the read ends normally the read contents are stored in the buffer memory for the read specified data.
- (d) The EEPROM read end signal (X1D) is turned off when the EEPROM read request (Y10) is turned off.

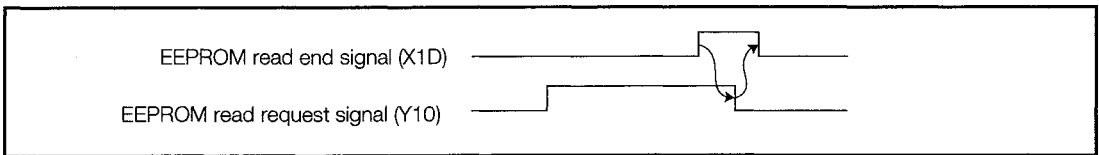

9 EEPROM write end signal (X1E)

- (a) When the EEPROM write request signal (Y11) is turned on, the write specified data is registered (stored) in the EEPROM, and the EEPROM write end signal (X1E) is turned on.
- (b) Whether the write was normal end or error end can be checked by reading the EEPROM write results storage area (buffer memory 115) of the buffer memory exchange state storage area. (Normal end when the storage value is 0 and error end when the storage value is anything but 0.)
- (c) The EEPROM write end signal (X1D) is turned off when the EEPROM write request (Y11) is turned off.

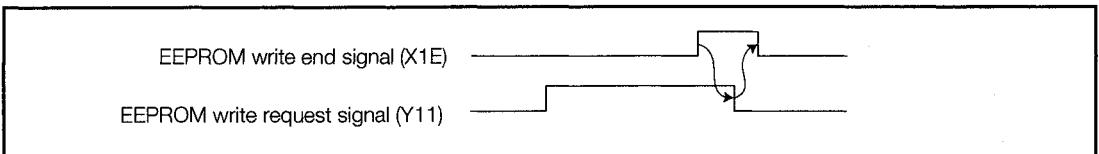

10 Watchdog timer error detection signal (X1F)

The watchdog timer detection signal (X1F) is turned on when a watchdog timer (approximately 300 ms) error occurs when the QE71 self diagnostic is used.

11 Transmission request and reception end check signal (Y0 to Y7)

This signal is used when fixed buffer exchange is conducted.

This signal is not used for random access buffer exchange and reading and writing data from the PLC CPU exchange.

Used as a transmission request signal when the appropriate fixed buffer is used for transmission.

Used as the reception end check signal when the appropriate fixed buffer is used for reception.

(a) When used as transmission request signal

When exchanging with procedure

- ① The QE71 transmits data to the remote node specified by the parameters when the transmission request signal (Y0 to Y7) is turned on by the sequence program.
- ② Transmission is ended when the transmission end signal (X0: when the fixed buffer is No. 1) when a response is returned from the remote node after data transmission.

When exchanging without procedure

- ① Data is transmitted by the QE71 to the remote node specified by the parameters when the transmission request signal (Y0 to Y7) is turned on by the sequence program.
- ② Transmission ends when the transmission end signal (X0: when the fixed buffer is No. 1) is turned on after the data is transmitted.

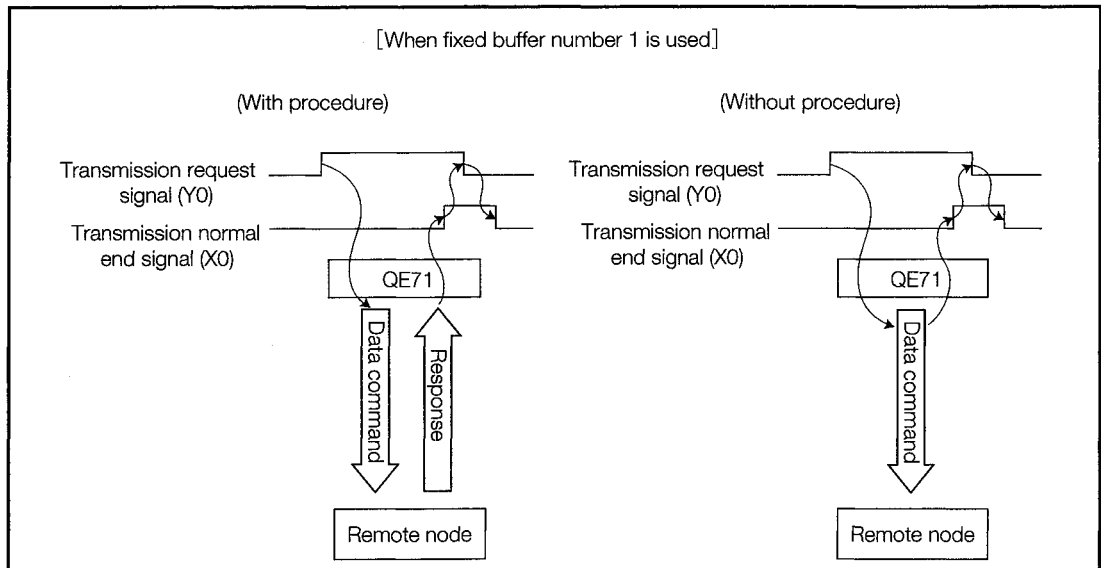

(b) When used as reception end check signal

When exchange with procedure

- ① The reception end signal (X2 : when the fixed buffer is No. 2) is turned on after the QE71 receives data from the remote node.
- ② A response is returned to the remote node when the reception end check signal (Y0 to Y7) is turned on after the reception end signal (X2: when the fixed buffer is No. 2) is in the on state after check by the sequence program. The reception end signal is automatically turned off after response transmission end

When exchange without procedure

- ① The reception end signal (X2 : when the fixed buffer is No. 2) is turned on after data is received to the QE71 from the remote node.
- ② The reception end signal is turned off when the reception end check signal (Y0 to Y7) is turned on and the reception end signal (X2: when the fixed buffer is No. 2) is in the on state after check by the sequence program.

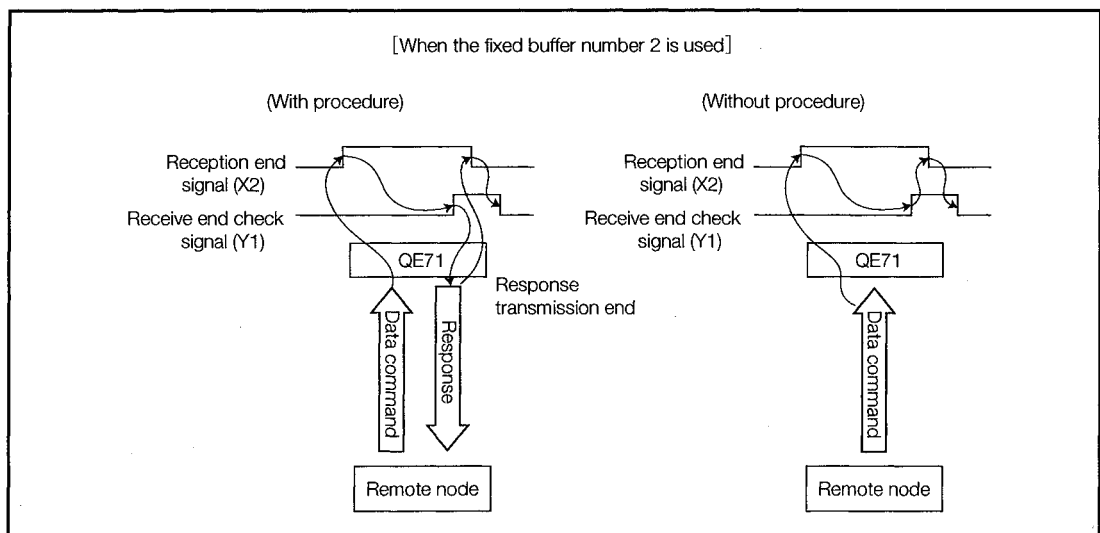

12 Open request signal (Y8 to YF)

- (a) This is the on signal for exchanging data (fixed buffer exchange, random access buffer exchange, reading and writing from the PLC CPU exchange) between the QE71 and the remote node.
- (b) When each connection open request signal (Y8 to YF) is turned on by the sequence program the exchange parameters are checked and if normal open processing is conducted. If error is detected the open error detection signal (X18) is turned on.
- (c) When the open request signal is on and open processing is conducted normally the open end signal (X10 to X17) is turned on. If an error is detected the open error detection signal (X18) is turned on.
- (d) The open error detection signal (X18) is turned off when the open request signal (Y8 to YF) is turned off. When errors occur at multiple connections, the open request signal for all connections where errors are occurring are turned off.

When the open error detection signal (X18) is turned ON, be sure to read the open error code storage area (buffer memory 93, 103, ...163) before the open request signal is turned ON again.

- (e) When turning OFF the open request signal, be sure that the I/O signals and other items related to the corresponding connection to the QE71 are in the following status:
 - Transmission request signal/receive end confirmation signal (Y0 to Y7), transmission normal completion signal/reception end signal (X0, X2 and beyond), transmission error detection signal (X1, X3 and beyond) are all OFF.

- Open end signal (X10 to X17) is ON. Or, if the open error detection signal (X18) is ON, the open error code for the corresponding connection is other than 0.
- * When “passive open” is specified in the open processing of TCP/IP communication, the open request signal can be turned OFF before the open end signal or open error detection signal turns ON. In such cases, when reopening processing using passive open, turn ON the open request signal (OFF @->@ ON) once 500ms have passed after the open request signal is turned OFF.

13 EEPROM read request signal (Y10)

This signal is used to read the initial processing parameters and exchange parameters, etc. that are registered in the EEPROM from the appropriate buffer memory.

(a) When the read parameter types are specified in the EEPROM parameter portion specification area (buffer memory 104) and when the EEPROM read request signal (Y10) is turned on, the specified parameters are read from the EEPROM to the buffer memory.

(b) The read parameters are stored in the parameter use state storage area (buffer memory 113) of the exchange state storage area.

The read results are stored in the exchange state storage areas EEPROM read result storage area (buffer memory 114). (Normal end when the stored value is 0 and error end when the stored value is anything but 0.)

(c) When the read result is error end, the read parameter data value is unspecified.

(d) When the read result is normal end, the read parameter data is validated by the following initial processing and open processing. This is not reflected in connections that have already been opened.

14 EEPROM write request signal (Y11)

This signal is used for storing (registering) the buffer memory initial processing parameters and exchange parameters, etc. by writing them into the EEPROM, and is also used for clearing the parameter types stored in the EEPROM.

When registering

(a) The parameters to be registered are written into the buffer memory.

(b) When the parameter types to be registered are specified in the EEPROM parameter portion specification area (buffer memory 104) and when the EEPROM write request signal (Y11) is turned on, the specified parameters are written to the EEPROM from the buffer memory.

(c) The write results are stored in the exchange state storage areas EEPROM write result storage area (buffer memory 115). (Normal end when the stored value is 0 and error end when the stored value is anything but 0.)

When clearing

(a) When the parameter types to be cleared and the EEPROM clear instructions are specified in the EEPROM parameter portion specification area (buffer memory 104), and the EEPROM write request signal (Y11) is turned on, and the parameters specified in the EEPROM are cleared.

(b) The clear results are stored in the exchange state storage areas EEPROM write result storage area (buffer memory 115).

(Normal end when the stored value is 0 and error end when the stored value is anything but 0.)

15 COM.ERR LED turn off request signal (Y17)

This signal is used to turn off the COM.ERR LED on the front of the QE71 that is lit when an exchange error occurs.

- (a) The COM.ERR LED is turned off when the turn off request signal (Y17) is turned on.
- (b) Normally, turn off processing is conducted when the turn off request signal (Y17) is on.
- (c) When the turn off request signal (Y17) is turned on, the error information in the buffer memory error log area is cleared (deleted).

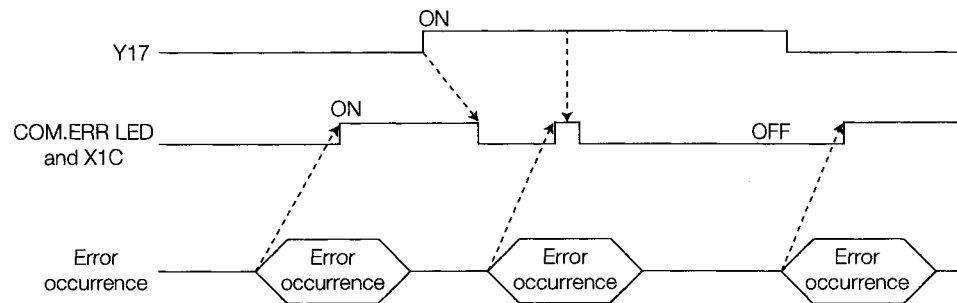

Point

The "COM. ERR" LED on the front panel of the QE71 can be turned off by clicking the **COM. ERR OFF** button on the "Ethernet Diagnosis" screen of GPPW. However, the error information in the error log area of the buffer memory will not be cleared (erased). For more details on the "Ethernet Diagnosis" screen of GPPW, refer to Section 17.4.1.

16 Initial request signal (Y19)

- (a) This signal is for conducting initialization before the QE71 conducts exchange.
- (b) Turning on the initial request signal (Y19), checks the initial parameters and if they are normal executes initial processing. If an error is detected the initial error detection signal (X1A) is turned on.

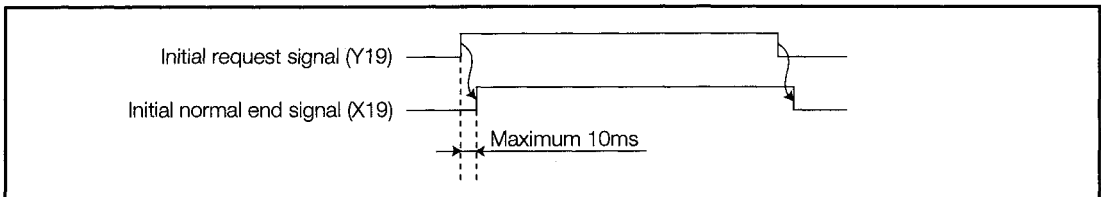

- (c) When the initial request signal is turned on and initial processing is conducted normally, the initial normal end signal (X19) is turned on. Here, if an error is detected, the initial error detection signal (X1A) is turned on.
- (d) When a QE71 system error occurs the initial error detection signal (X1A) is turned on. Please turn off the initial request signal (Y19). The error code at this time is stored in the initial error code storage area (buffer memory105).
- (e) After checking that the following signals are turned off, turn off the initial request signal.
 - Transmission request signal/reception end check signal (Y0 to Y7)
Transmission normal end signal/reception end signal (X0, X2...)
 - Transmission error detection signal (X1, X3...)
 - Open request signal (Y8 to YF)
Open end signal (X10 to X17)
Open error detection signal (X18)

3.7 Buffer Memory

This section explains about the PLC CPU and the data reception buffer memory in the QE71.

3.7.1 Buffer Memory Applications

The buffer memory is composed of the following user areas and system area.

1 User area

- ① This is the area that the user reads and writes data.
- ② These areas are the areas where the parameter types are set and registered to the EEPROM for initial processing and data exchange, data exchange areas, and areas for storing exchange state and exchange error information.
- ③ The default values used when the QE71 is booted up are stored in the parameter settings area for initial processing and data exchange. These default values make exchange with a remote node possible, but sometimes they need to be changed. Before conducting processing, write the set values only into the areas that need to be changed.
- ④ When reading from and writing to the user area, please follow the detailed instruction items. In addition, only execute post reading and writing (FROMP, TOP, etc.) when necessary. The data exchange time sometimes becomes long during normal execution.

Point

- ① Parameter types setting area setting values (including setting values that can be changed by the user) for the initial processing and data exchange, can be registered into the QE71's EEPROM. After checking that the data transmission to and from the remote node is being conducted normally, it is recommended that the settings values are registered in the QE71's EEPROM and used as the default values when the QE71 is booted up.
 - * Using the settings values registered in the QE71's EEPROM as the default values makes a default value change portion sequence program unnecessary.
- ② For information regarding registration to the QE71's EEPROM, please refer to Item 4.9.

2 System area

This is the area used by the QE71.

In addition to the system areas shown in Item 3.7.2, system areas partially exist in the user areas described in **1** above.

Important

Do not write data in the "system area" in the buffer memory of the special function module. If data is written to the "system area," it may result in malfunctions of the PLC system.

3.7.2 List of Buffer Memory Allocations

The buffer memory is comprised of 1 address of 16 bits. The overall configuration of the buffer memory is shown below. For details regarding each area, please refer to the explanation references shown on the right side of each area.

(How to read the buffer memory address)

Addresses are written using the following method and the same explanation is given hereafter.

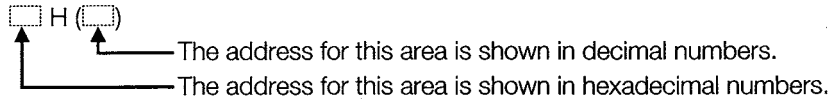

(Address)	Buffer memory		Detailed explanation
0 to 1FH (0 to 31)	Initial processing parameter setting area (32 words)		Item 5.2.2
20 to 5FH (32 to 95)	Exchange parameter setting area (64 words)		Item 5.5.1
60 to 66H (96 to 102)	Systems area (Use prohibited...7 words)		————
67H (103)	Exchange instruction area during STOP (1 word)		Chapter 16
68H (104)	EEPROM parameter portion specification area (1 word)		Item 5.8.2
69 to DFH (105 to 223)	Exchange state storage area	Exchange state storage area (119 words)	Item 5.6.1
E0 to 1FFH (224 to 511)		Error log area (288 words)	Item 5.6.2
200 to 201H (512 to 513)	Subnet mask settings area (2 words)		Item 11.2
202 to 225H (514 to 549)	Router relay parameter setting area (36 words)		Item 12.4
226 to 227H (550 to 551)	Systems area (Use prohibited...2 words)		————
228 to 3AAH (552 to 938)	Station No. <-> IP information setting area (387 words)		Item 15.3.4
3AB to 3AFH (939 to 943)	Systems area (Use prohibited...5 words)		————
3B0 to 3BFH (944 to 959)	FTP parameter setting area (16 words)		Item 13.3
3C0 to 67FH (960 to 1663)	Systems area (Use prohibited...704 words)		————
680 to A7FH (1664 to 2687)	Fixed buffer exchange area	Set buffer No. 1 (1024 words)	Chapter 6 Chapter 7
A80 to E7FH (2688 to 3711)		Set buffer No. 2 (1024 words)	
to		to	
		Set buffer No. 8 (1024 words)	
2280 to 267FH (8832 to 9855)	Random access buffer exchange area	Random access buffer (6144 words)	Chapter 8
2680 to 3E7FH (9856 to 15999)			

* In the buffer memory lists shown beginning on the next page, the setting values in <Pa> areas can be set by Software shown in Section 2.2(4). For more details on the setting values, see the corresponding explanatory items in this manual. For more details on the setting method, refer to the Software Manual to use.

Point

The access from PLC CPU is given priority over other special function module processing. Therefore, if the PLC CPU frequently accesses the buffer memory of a special function module, not only the scan time of the PLC CPU is prolonged, but each processing of the special function module is delayed. Perform access to the buffer memory from the PLC CPU using FROM/TO instruction or other means only when it is necessary.

(Address)	Buffer memory	Default value	Detailed explanation	
0 to 1H (0 to 1)	Local station QE71's IP address (2 words)	<Pa> C00001FEH	Item 5.2.2	
2 to 3H (2 to 3)	System area (2 words)	——		
4H (4)	Special function setting (1 word)	<Pa> 100H (256)		
5 to AH (5 to 10)	System area (6 words)	——		
BH (11)	TCP ULP time out value (1 word)	3CH (60)		
CH (12)	TCP zero window timer value (1 word)	14H (20)		
DH (13)	TCP retransmission timer value (1 word)	14H (20)		
EH (14)	TCP end timer value (1 word)	28H (40)		
FH (15)	IP setup timer value (1 word)	0AH (10)		
10H (16)	Response monitoring timer value (1 word)	3CH (60)		
11H (17)	Destination existence check start interval timer value (1 word)	4B0H (1200)		
12H (18)	Destination existence check interval timer value (1 word)	14H (20)		
13H (19)	Number of retransmit tries for destination existence check (1 word)	3H (3)		
14H (20)	Automatic open UDP port No. (1 word)	1388H (5000)		
15 to 1DH (21 to 29)	System area (9 words)	——		
1EH (30)	TCP Maximum Segment transmission setting (*1) (1 word)	8000H		
1FH (31)	System area (1 word)	——		
20H (32)	Connection No.1	Usage available settings area (1 word each)		Item 5.5.1
21H (33)	Connection No.2			
22H (34)	Connection No.3			
23H (35)	Connection No.4			
24H (36)	Connection No.5			
25H (37)	Connection No.6			
26H (38)	Connection No.7			
27H (39)	Connection No.8			
28H (40)	QE71's port No.	0H (0)		
29 to 2AH (41 to 42)	Remote node IP address	Exchange address setting area	0H (0)	
2BH (43)	Remote node port No.	(connection No.1 7words)	0H (0)	
2C to 2EH (44 to 46)	Remote node Ethernet address		FFFFFFFFFFFFH	
2F to 35H (47 to 53)	QE71's port No.	Exchange address setting area (connection No.2 7words)	(Same as connection No.1)	
36 to 3CH (54 to 60)	QE71's port No.	Exchange address setting area (connection No.3 7words)		
3D to 43H (61 to 67)	QE71's port No.	Exchange address setting area (connection No.4 7words)		
44 to 4AH (68 to 74)	QE71's port No.	Exchange address setting area (connection No.5 7words)		
4B to 51H (75 to 81)	QE71's port No.	Exchange address setting area (connection No.6 7words)		
52 to 58H (82 to 88)	QE71's port No.	Exchange address setting area (connection No.7 7words)		
59H (89)	QE71's port No.	0H (0)		
5A to 5BH (90 to 91)	Remote node IP address	Exchange address setting area		
5CH (92)	Remote node port No.	(connection No.8 7words)	0H (0)	
5D to 5FH (93 to 95)	Remote node Ethernet address		FFFFFFFFFFFFH	
60 to 66H (96 to 102)	System area (7 words)	——	——	
67H (103)	Exchange instruction area during STOP (1 word)	0H (0)	Item 16.2	

(to the next page)

(continued from the previous page)

(Address)		Buffer memory	Default value	Detailed explanation
68H (104)	EEPROM parameter portion specification (1 word)	0H (0)	Item 5.8.2
69H (105)	Initial error code (1 word)	0H (0)	
6A to 6BH (106 to 107)	Local station QE71's IP address (2 words)	0H (0)	
6C to 6EH (108 to 110)	Local station QE71's Ethernet address (3 words)	0H (0)	
6FH (111)	System area (1 word)	_____	
70H (112)	EEPROM register status (1 word)	AAAH (2730)	
71H (113)	Parameter use status (1 word)	0H (0)	
72H (114)	EEPROM read result (1 word)	0H (0)	
73H (115)	EEPROM write result (1 word)	0H (0)	
74H (116)	Automatic open UDP port No. (1 word)	0H (0)	
75H (117)	System area (1 word)	_____	
76H (118)	Network No. station No. MELSECNET/10 relay exchange	<Pa> 0H (0)	
77H (119)	Group No. local station information (2 words)	<Pa> 0H (0)	
78H (120)	Local station QE71's port No.	0H (0)	
79 to 7AH (121 to 122)	Remote node IP address	0H (0)	
7BH (123)	Remote node port No.	0H (0)	
7CH (124)	Open error code	0H (0)	
7DH (125)	Fixed buffer transmission/reception error code	0H (0)	
7EH (126)	Connection end code / Error log	0H (0)	
7FH (127)	Maximum value	0H (0)	
80H (128)	Minimum value	0H (0)	
81H (129)	Current value	0H (0)	
82 to 8BH (130 to 139)	Local station QE71's port No. Information by connection (connection No.2 10 words)	(Same as connection No. 1)	
8C to 95H (140 to 149)	Local station QE71's port No. Information by connection (connection No.3 10 words)		
96 to 9FH (150 to 159)	Local station QE71's port No. Information by connection (connection No.4 10 words)		
A0 to A9H (160 to 169)	Local station QE71's port No. Information by connection (connection No.5 10 words)		
AA to B3H (170 to 179)	Local station QE71's port No. Information by connection (connection No.6 10 words)		
B4 to BDH (180 to 189)	Local station QE71's port No. Information by connection (connection No.7 10 words)		
BE to C7H (190 to 199)	Local station QE71's port No. Information by connection (connection No.8 10 words)		
C8H (200)	LED lighted state Left side		0H (0)
C9H (201)	(1 word each) Right side	0H (0)	
CAH (202)	Operation mode setting switch setting status (1 word)	(Switch setting value)	
CBH (203)	Exchange condition setting switch setting status (1 word)	(Switch setting value)	
CC H (204)	System area (1 word)	_____	
CD H (205)	RECV command execution request (1 word)	0H (0)	
CE H (206)	System area (1 word)	_____	
CF to DFH (207 to 223)	Data link command execution result by channel (17 words)	0H (0)	
E0 to E2H (244 to 226)	System area (3 words)	_____	Item 5.6.2
E3H (227)	Number of errors generated (1 word)	0H (0)	
E4H (228)	Error log write pointer (1 word)	0H (0)	

(to the next page)

(continued from the previous page)

(Address)	Buffer memory	Default value	Detailed explanation
E5H (229)	Error code · End code	0H (0)	Item 5.6.2
E6H (230)	Subheader	0H (0)	
E7H (231)	Command code	0H (0)	
E8H (232)	Connection No.	0H (0)	
E9H (233)	Local station QE71 port No.	0H (0)	
EA to EBH (234 to 235)	Remote node IP address (9 words)	0H (0)	
ECH (236)	Remote node port No.	0H (0)	
EDH (237)	System area	————	
EE to F6H (238 to 246)	Error code · End code	————	
to	to	(Same as error log block 1)	
16C to 174H (364 to 372)	Error code · End code	————	
175 to 177H (373 to 375)	System area (3 words)	————	
178 to 179H (376 to 377)	Total number of IP packet received (2 words)	0H (0)	
17A to 17BH (378 to 379)	Total number of received IP packets discarded due to check sum errors (2 words)	0H (0)	
17C to 17DH (380 to 381)	Total number of transmitted IP packets (2 words)	0H (0)	
17E to 17FH (382 to 383)	System area (2 words)	————	
180 to 181H (384 to 385)	Number of received ARP packets (2 words)	0H (0)	
182 to 183H (386 to 387)	Number of responses to ARP packets (2 words)	0H (0)	
184 to 185H (388 to 389)	Number of received IP packets that are not broadcasted to local station (2 words)	0H (0)	
186 to 187H (390 to 391)	System area (2 words)	————	
188 to 189H (392 to 393)	Number of transmitted ARP packets (2 words)	0H (0)	
18A to 18BH (394 to 395)	Number of transmitted broadcast packets (2 words)	0H (0)	
18C to 197H (396 to 407)	System area (12 words)	————	
198 to 199H (408 to 409)	Total number of received ICMP packets (2 words)	0H (0)	
19A to 19BH (410 to 411)	Total number of ICMP packets discarded due to check sum errors (2 words)	0H (0)	
19C to 19DH (412 to 413)	Total number of transmitted ICMP packets (2 words)	0H (0)	
19E to 19FH (414 to 415)	Total number of received ICMP echo request packets (2 words)	0H (0)	
1A0 to 1A1H (416 to 417)	Total number of transmitted ICMP echo reply packets (2 words)	0H (0)	
1A2 to 1A3H (418 to 419)	Total number of transmitted ICMP echo request packets (2 words)	0H (0)	
1A4 to 1A5H (420 to 421)	Total number of received ICMP echo reply packets (2 words)	0H (0)	
1A6 to 1B7H (422 to 439)	System area (18 words)	————	
1B8 to 1B9H (440 to 441)	Total number of received TCP packets (2 words)	0H (0)	
1BA to 1BBH (442 to 443)	Total number of received TCP packets discarded due to check sum errors (2 words)	0H (0)	
1BC to 1BDH (444 to 445)	Total number of transmitted TCP packets (2 words)	0H (0)	
1BE to 1BFH (446 to 447)	Number of ZERO-Window time-outs (2 words)	0H (0)	
1C0 to 1D7H (448 to 471)	System area (24 words)	————	
1D8 to 1D9H (472 to 473)	Total number of received UDP packets (2 words)	0H (0)	

(to the next page)

(continued from the previous page)

(Address)	Buffer memory	Default value	Detailed explanation
1DA to 1DBH (474 to 475)	Total number of received UDP packets discarded due to check sum errors (2 words)	0H (0)	Item 5.6.2
1DC to 1DDH (476 to 477)	Total number of transmitted UDP packets (2 words)	0H (0)	
1DE to 1DFH (478 to 479)	Number of times received UDP packets discarded due to incorrect destination (2 words)	0H (0)	
1E0 to 1FFH (480 to 511)	System area (32 words)	-----	
200 to 201H (512 to 513)	Subnet mask field (2 words)	<Pa> 0H (0)	Item 11.2
202 to 203H (514 to 515)	Default router IP address (2 words)	<Pa> 0H (0)	Item 12.4
204H (516)	Number of registered routers (1 word)	<Pa> 0H (0)	
205 to 206H (517 to 518)	Router 1 setting Subnet address 1 (2 words)	<Pa> 0H (0)	
207 to 208H (519 to 520)	Router IP address 1 (2 words)	<Pa> 0H (0)	
to	to	-----	
221 to 222H (545 to 546)	Router 8 setting Subnet address 8 (2 words)	<Pa> 0H (0)	
223 to 224H (547 to 548)	Router IP address 8 (2 words)	<Pa> 0H (0)	
225H (549)	System area (1 word)	-----	
226 to 227H (550 to 551)	System area (2 words)	-----	
228H (552)	The number of conversion table data (1 word)	<Pa> 0H (0)	Item 15.3.4
229 to 22AH (553 to 554)	Network number and station number of the exchange request destination station /exchange request origin station Conversion information (No.1) (6 words)	<Pa> 0H (0)	
22B to 22CH (555 to 556)	Local network QE71's IP address	<Pa> 0H (0)	
22D to 22EH (557 to 558)	System area	-----	
22F to 230H (559 to 560)	Network number and station number of the exchange request destination station /exchange request origin station Conversion information (No.2) (6 words)	<Pa> 0H (0)	
231 to 232H (561 to 562)	Local network QE71's IP address	<Pa> 0H (0)	
233 to 234H (563 to 564)	System area	-----	
to	to	<Pa> to	
3A3 to 3A4H (931 to 932)	Network number and station number of the exchange request destination station /exchange request origin station Conversion information (No.64) (6 words)	<Pa> 0H (0)	
3A5 to 3A6H (933 to 934)	Local network QE71's IP address	<Pa> 0H (0)	
3A7 to 3A8H (935 to 936)	System area	-----	
3A9 to 3AAH (937 to 938)	Net mask pattern for MELSECNET/10 routing (2 words)	<Pa> 0H (0)	
3AB to 3AFH (939 to 943)	System area (5 words)	-----	
3B0 to 3B5H (944 to 949)	FTP log in name (6 words)	<Pa> "AJ71QE71"	Item 13.3
3B6 to 3B9H (950 to 953)	Password (4 words)	<Pa> "AJ71QE71"	
3BAH (954)	Command input monitoring timer (1 word)	<Pa> 708H(1800)	
3BBH (955)	ACPU monitoring timer (1 word)	<Pa> AH(10)	
3BC to 3BFH (956 to 959)	System area (4 words)	-----	
3C0 to 67FH (960 to 1663)	System area (704 words)	-----	
680 to A7FH (1664 to 2687)	Fixed buffer No.1 (1024 words)	0H (0)	Chapter 6 Chapter 7
A80 to E7FH (2688 to 3711)	Fixed buffer No.2 (1024 words)		
E80 to 127FH (3712 to 4735)	Fixed buffer No.3 (1024 words)		
1280 to 167FH (4736 to 5759)	Fixed buffer No.4 (1024 words)		
1680 to 1A7FH (5760 to 6783)	Fixed buffer No.5 (1024 words)		
1A80 to 1E7FH (6784 to 7807)	Fixed buffer No.6 (1024 words)		
1E80 to 227FH (7808 to 8831)	Fixed buffer No.7 (1024 words)		
2280 to 267FH (8832 to 9855)	Fixed buffer No.8 (1024 words)		
2680 to 3E7FH (9856 to 15999)	Random access buffer (6144 words)	0H (0)	Chapter 8

*1 Applicable to the products of the following software versions.

AJ71QE71N3-T, A1SJ71QE71N3-T : "Version A" and later

Other QE71 : "Version E" and later

The TCP Maximum Segment transmission function is not applicable to the products earlier than the above. This area is used as a system area.

4. SETTINGS AND PROCEDURES UP TO OPERATION

This section explains the procedures and the setting methods for the system that uses QE71 up to the point of QE71 operation.

4.1 Abbreviated Procedures Up to Operation

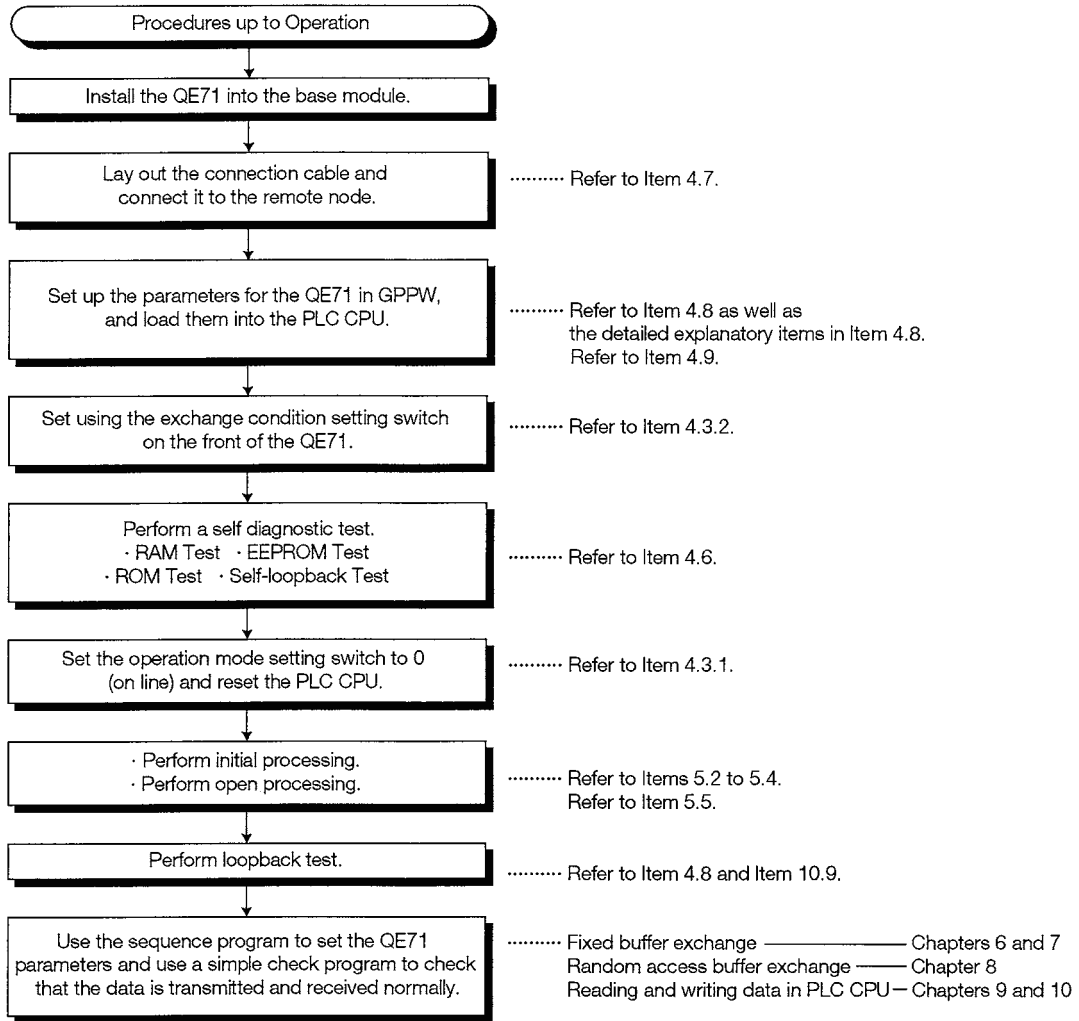

! DANGER

- Do not touch the connector while the power is on. Doing so could cause malfunction.
- Make sure to switch off all phases of the external power supply used by the system before cleaning or re-tightening screws. Otherwise, it will cause failure or malfunctions of the module. If the screws are loose, it may result in fallout, short circuits, or malfunctions. Tightening the screws too far may cause damage to the screw and/or the module, resulting in fallout, short circuits, or malfunctions.

! CAUTION

- Do not disassemble or modify the modules. Doing so could cause trouble, malfunction, injury, or fire.
- Make sure to switch off all phases of the external power supply used by the system before mounting or removing the module. Otherwise, it will cause failure or malfunction of the module.

4.2 Names of Parts

This section explains the names and setting method for the QE71 parts.

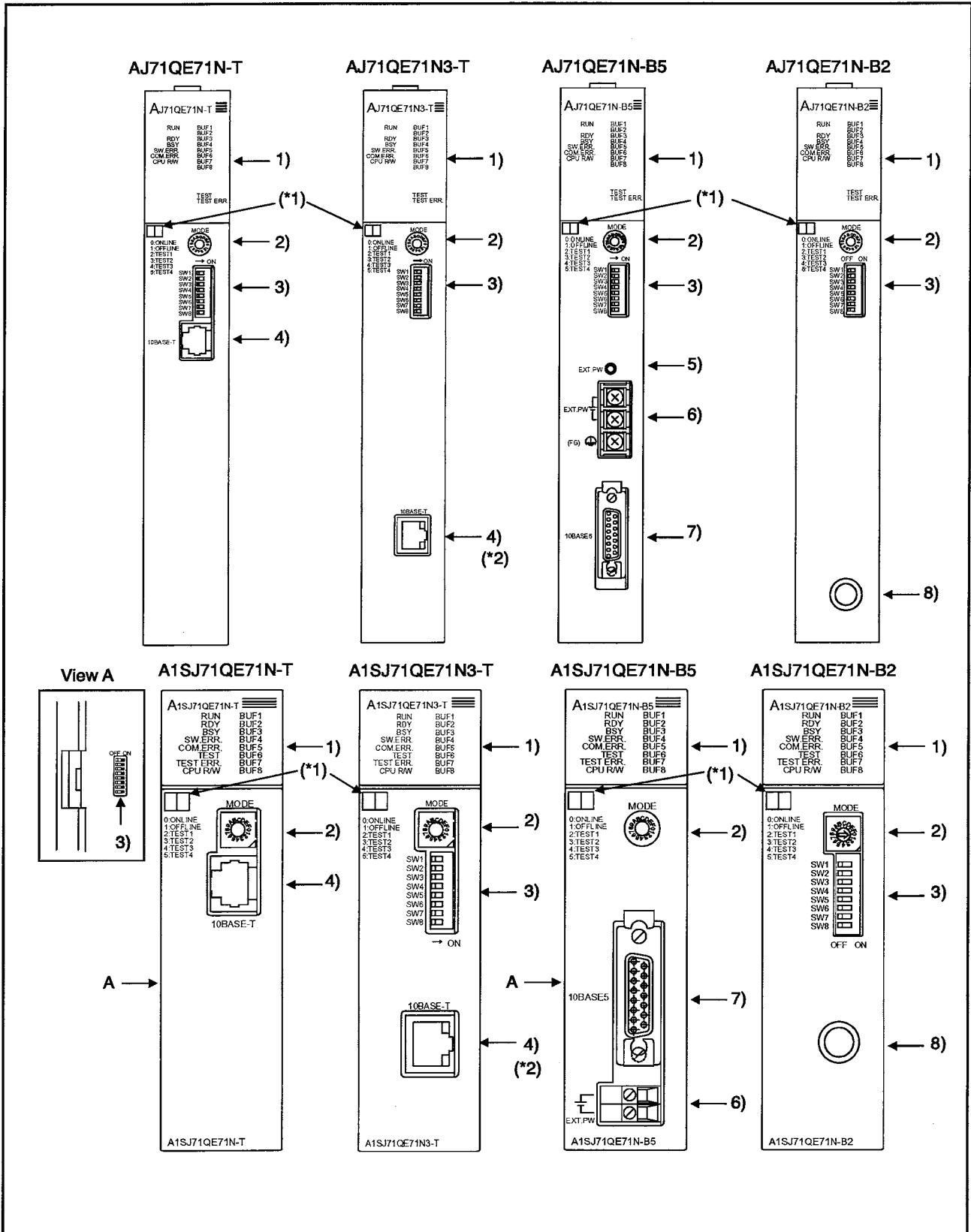

*1 The sticker indicates the hardware version and software version of the module.

(Example)

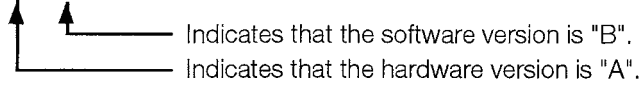
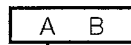

*2 The LED on the connector does not turn on.

No.	Name	Description and explanation	Reference item
①	Display LED	Displays the operating state, data transmission and reception, and error description. The description when the LED is turned on or off varies for each LED.	Item 4.4
②	Operation mode setting switch	Select from on-line, off-line, self diagnostic test, or operation mode. Normally on-line is selected. The setting at the time of factory shipment is 0 (on-line).	Item 4.3.1
③	Exchange condition setting switch	Selects the start up conditions, exchange processing conditions, code types during exchange, and whether there is TCP time out error processing. The setting at the time of factory shipment is that SW1 to SW8 are all turned off.	Item 4.3.2
④	10BASE-T connector (RJ45)	This connector used to connect the QE71 to the 10BASE-T	Item 4.7.4
⑤	External power supply indicator lamp	This light confirms that power is being supplied to the transceiver. ON: Power is being supplied OFF: Power has not been supplied	Item 2.3
⑥	External power supply terminal	Power supply terminal for supplying power to the transceiver.	Item 2.3
⑦	AUI cable connector	This connector is used to connect the QE71 to the 10BASE5.	Item 2.3 Item 4.7.2
⑧	10BASE2 connector	This connector is used to connect the QE71 to the 10BASE2.	Item 2.3 Item 4.7.3

4.3 Switch Settings

4.3.1 Operation Mode Settings

Table 4.1 List of Operation Mode Settings and Descriptions

Operation mode setting switches	Setting No.	Setting name	Settings description
	0	On-line	Conducts exchange with remote node in the normal operation mode.
1	Off-line	Disconnects the local station from the network.	
2	Test 1	Conducts a self diagnostic test using a self-loopback test.	
3	Test 2	Conducts a RAM test.	
4	Test 3	Conducts a ROM test.	
5	Test 4	Conducts an EEPROM test.	
6			Usage not possible
7			
8			
9			
A			
B			
C			
D			
E			
F			

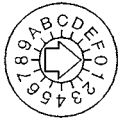

Point

When changing the operation mode, reset the PLC CPU after changing the operation mode setting switch. The resetting operation will start up the selected operation mode.

4.3.2 Exchange Condition Settings

Exchange condition setting switch	Switch	Setting items	Setting description	At time of factory shipment	
	SW1	Line processing selection during TCP time out error	Selects the line processing when the TCP ULP time out error occurs. Off: Closes the line when the TCP ULP time out error occurs. On: Does not close the line even if a TCP ULP time out error occurs.	OFF	
	SW2	Data code setting	Selects the type of data code for exchanging data with the remote node. Off: Conducts exchange in binary code. On: Conducts exchange in ASCII code.	OFF	
	SW3	Automatic start up mode setting (Self start mode setting)	Selects the start method when the QE71 is booted up. Off: Runs following Y19 (initial processing request signal). On: Reads the parameters in the EEPROM buffer memory regardless of the Y19 (initial processing request signal) after power has been turned on or the module reset and then conducts initial processing of the contents.	OFF	
	SW4	Usage not possible (Fixed to off)			OFF
	SW5	Usage not possible (Fixed to off)			OFF
	SW6	Usage not possible (Fixed to off)			OFF
	SW7	CPU exchange timing setting	Selects whether to approve or forbid data arriving from the remote node when a PLC CPU is running. Off: Forbids writing from the remote node when the PLC CPU is running. On: Conducts writing from the remote node when the PLC CPU is running.	OFF	
	SW8	Initial timing setting	Selects the initial processing start up timing. Off: Quick start (starts without a delay time) Set when one network is used for the entire configuration. On: Normal start (starts after a delay of 20 seconds) Use when the entire configuration is made up of multiple networks.	OFF	

1

Line processing selection during TCP time out error (SW1)

A TCP ULP time out error occurs when an ACK is not returned, even when the specified retry processing is conducted when using the TCP/IP communication. Selects the connection processing at this time.

Normally set this switch to OFF. To set this switch to ON, perform the close processing and open processing of the communication line using a sequence program when a TCP ULP time out error (error code: C032H) has occurred in data exchange with a remote node.

To add to the above, FTP connection has nothing to do with the main switch setting, and the line is closed when a time-out error occurs.

2

Data code setting (SW2)

Selects the data code type (binary, ASCII) when conducting data exchange with a remote node. (Refer to Item 3.3)

3

Initial timing setting (SW8)

Freezes for approximately 20 seconds a connection that has been closed once when using TCP/IP communication. Because there will be a wait when the same IP address and the same port No. are reopened, the system start up time should be set in anticipation of this. This setting will change the time from when the initial request signal (Y19) is turned on, to when the initial normal end signal (X19) is turned on. Normally set this to OFF.

4

After the power is turned on, the only switch that can be changed is SW3.

Any switches other than SW3 that are changed after the power is turned on will be ignored.

Point

With the exception of SW3, all exchange condition setting switches should be set when the QE71's power is turned off.

4.4 Description of Display LED's Display

This section explains the signal names and describes the displays of the display LEDs on the top front of the QE71.

Table 4.2 List of the Display LEDs and the Display Contents

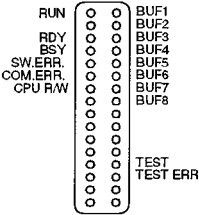
Display LEDs	LED names	Description of LED displays	When the LED is on	When the LED is off	
	AJ71QE71N3-T AJ71QE71N-T AJ71QE71N-B5 AJ71QE71N-B2  TEST TEST ERR.	RUN	Normal operation display	Normal	Error
RDY		Exchange ready end display	Starts flashing when on-line operations begin.		
BSY		Exchange processing executing display	Turns on when exchange processing with remote node is being executed.		
SW. ERR.		CPU error, CPU type error display	Error	Normal	
COM.ERR.		Exchange error detection display (Refer to Item 17.2*1)	Exchange error	Normal	
CPU R/W		Exchange processing executing with PLC CPU display	Exchanging	Not exchanging	
BUF 1		Connection No.1	Communication line connection state display	Open completed	Closed state
BUF 2		Connection No.2			
BUF 3		Connection No.3			
BUF 4		Connection No.4			
BUF 5		Connection No.5			
BUF 6		Connection No.6			
BUF 7		Connection No.7			
BUF 8		Connection No.8			
TEST		Self diagnostic executing display	Valid only during self diagnosis	Self diagnosis executing	Self diagnosis completed
TEST ERR.	Self diagnosis results display	Error		Normal	

- (1) For the above LEDs, when RUN turns off after the power is turned on, a watchdog timer error can be suspected. The watchdog timer error detection signal (X1F) will also turn on.
- (2) Of the above LEDs, RDY will flash when operation is started by the on-line mode (the mode setting switch is set to 0). When the exchange condition setting switch's initial timing set (SW8) starts normally, RDY will flash approximately 20 seconds after operation has been started by the on-line mode.
- (3) Of the above LEDs, the BSY exchange processing executing is done during the following times. BSY is lit during the processing of re-try when transmitting data.
 - (a) For Transmission Procedure
 - Until a reception response is received from the command transmission
 - Until a transmission error occurs from the command transmission (until time out)
 - (b) For Reception Procedure
 - Until a response is returned from the command reception
- (4) For the LEDs shown in Table 4.2, the BUF1 to BUF8 communication line connection state shows the line connection state with the partner set by the exchange parameters. The open completed signal (X10 to X17) ON/OFF state can be checked using these LEDs. Here data can only be exchanged using connections that are opened.
- (5) Of the above-mentioned LED's, COM.ERR goes off by the COM.ERR LED off request signal (Y17).

(6) The following statuses can be checked with the display LEDs of the QE71.

	LED name	Status to check (*1)	Cause/corrective action
1	[RUN]	Stays off even after the power is on. (*2)	① Watchdog timer error When an abnormality of the operation of the QE71 itself is detected by the self diagnosis function of the QE71, the watchdog timer error detection signal (X1F) turns on. ② QE71 installation failure <ul style="list-style-type: none"> • Check whether or not the power supply capacity (5 VDC) of the power supply module is sufficient. • Turn off the power supply and reinstall the QE71.
2	[RDY]	Stays off even after initial processing. (*2)	Using GPPW, check/modify the setting values of the parameters for the initial processing of the QE71.
3	[SW. ERR.]	Turns on after powering on the QE71. (*2)	① Check whether the PLC can install the QE71. ② PLC CPU error When the PLC CPU's [RUN] LED is off/flashing, or the [ERR.] LED is on, check the content of the error occurring in the PLC CPU, and correct the problem.
4	[COM. ERR.]	Turns on after powering on the QE71.	① Check the content of the error according to the error code stored when an error is detected in any of the following processing, and remove the error cause. (Refer to *1 in Item 17.2.) <ul style="list-style-type: none"> • Initial processing • Open processing • Fixed buffer transmission processing • Data exchange processing • Other processing (processing for which an error code is stored in the error log area) ② For a list of error codes, refer to Item 17.1.
5	[TEST ERR.]	Turns on after a self-diagnostic test.	① Hardware failure of the QE71 ② Poor cable connections, line abnormality Check the cable connections. (*3) ③ Abnormality of 12 VDC external supply power (only when a 10BASE5 is connected) Check by referring to Item 2.3.

*1 The ON status is also stored in the LED ON status storage area of the buffer memory (address: C8H, C9H).

*2 By performing a self-diagnosis test, check whether the QE71 operates normally. (Refer to Item 4.6.)

*3 Be sure to check the completion of the initial processing of the QE71 and whether there are any problems in the cable connections and Ethernet line (Refer to Item 17.3).

4.5 Mounting and Installation

This section explains the handling precautions that are common for modules, and about the installation environment from the time the QE71 is unpacked until installation.

For details regarding module mounting and installation, please refer to the user's manual of the PLC CPU module to use.

4.5.1 Handling Precautions

This section explains the handling precautions for the QE71 module itself.

- (1) The QE71's case is made of plastic, so do not drop it or subject it to strong impacts.
- (2) The tightening torque for module terminal screws and fixing screws should be kept within the following range.

Screw locations	Tightening torque range
External power supply terminal screws (*1)	AJ71QE71N-B5 : 98 to 137 N · cm (M4 screws) A1SJ71QE71N-B5 : 40 N · cm (M2.5 screws)
Module fixing screws	78 to 118 N · cm (M4 screws)

*1 This terminal is used as an external power input terminal for supplying power to the transceiver when being connected to a 10BASE5.

CAUTION

- Insert the fixing latch on the bottom of the module into the fixing hole in the base unit and install the module using the hole point as a fulcrum.
(The Q2AS series module shall be fastened to the base unit by screws using the specified torque.)
If the module is not properly installed, it may result in malfunctions, breakdowns, or the module may fall off.
- Be sure there are no foreign substances such as sawdust or wiring debris inside the module. Such debris could cause fires, damage, or malfunction.
- Do not disassemble or modify the modules. Doing so could cause trouble, malfunction, injury, or fire.
- Shut off all phases of the external power supply in the system before mounting or dismantling the module. Otherwise, it will cause failure or malfunction of the module.
- Tighten the terminal screws within the range of specified torque.
If the terminal screws are loose, it may result in short circuits or malfunctions.
Tightening the screws too far may cause damage to the screw and/or the module, resulting in fallout, short circuits, or malfunctions.
- Do not directly touch the module's conductive parts or electronic components. Doing so could cause malfunction or trouble in the module.
- When disposing of this product, treat it as industrial waste.
- When using the module while values, such as buffer memory set values, are registered in the EEPROM, do not turn off the power supply for the module loading station nor reset the PLC CPU. If the power supply for the module loading station is turned off or the PLC CPU is reset while any values are registered, the data contents in the EEPROM become inconsistent and as a result the values must be set again in the buffer memory, etc. and reregistered to the EEPROM. Also this may cause failure and malfunctions of the module.

4.5.2 Installation Environment

The following environments should be avoided when installing the QnA series PLC.

- Areas where the temperature range of the surrounding temperature is outside 0 to 55 degrees Celsius.
- Areas where the surrounding humidity exceeds the range of 10 to 90% RH
- Areas where there are sharp changes in humidity or where condensation forms
- Areas where there are corrosive gases or flammable gases
- Areas where there are conducting powders such as dust or iron dust, and where there is oil mist, salt, or organic solvents
- Locations that are struck by direct sunlight
- Areas where there are strong electric fields or strong magnetic fields
- Areas where direct vibrations or shocks will be transmitted to the module

 **CAUTION**

- Use the PLC in an environment that meets the general specifications contained in this manual. Using this PLC in an environment outside the range of the general specifications could result in electric shock, fire, malfunction, and damage to or deterioration of the product.

4.6 Self Diagnostic Test

This section explains the self diagnostic test that is used to check the QE71's transmission and reception functions and its hardware.

4.6.1 Self-Loopback Test

This section explains the self-loopback test that is used to check the hardware that includes the QE71's transmission and reception lines.

The ERROR LED of the QnACPU may flicker during the self loop back test, but this is not an error.

The self-loopback test is a check that transmits a test message to the QE71's own node via a line, and that can receive the same message via the network.

Following is an explanation of the self-loopback test. This test is conducted in approximately 2 seconds.

Self-loopback test method

- ① Connect the QE71 to the line. (Refer to Item 4.7)
- ② Set the operation mode setting switch on the front of the QE71 to the 2 position.
- ③ Set the PLC CPU's RUN/STOP key switch to the STOP position.
- ④ When the PLC CPU is reset, the self-loopback test will begin.

Test results

The test results can be determined from the LEDs on the front of the QE71.

- ① If the TEST LED is turned off, then the self-loopback test is completed.
- ② The test results can be checked using the TEST ERR.'s LED.
 - When normal LED is turned off
 - When error The LED is lit
- ③ The following can be suspected causes of errors.
 - QE71 hardware error
 - Ethernet line error
 - External power supply 12VDC error (Only 10BASE5)

Operation after the test is completed

The PLC CPU can be reset after the on-line mode or another test mode is switched using the operation mode setting switch on the front of the QE71.

Point

There will be no hardware interference if the self-loopback test is conducted while another mode is on-line. If there is a packet in the line, this test may not finish within approximately 2 seconds if interference occurs with the packet. In this case, perform the test after terminating the data exchange with the remote node.

4.6.2 RAM Test

This section explains the RAM test that is performed to check the QE71's RAM.
The ERROR LED of the QnACPU may flicker during the RAM test, but this is not an error.

RAM test method

- ① Set the operation mode setting switch on the front of the QE71 to the 3 position.
- ② Set the PLC CPU's RUN/STOP key switch to the STOP position.
- ③ When the PLC CPU is reset, the RAM test will begin.

Test results

The test results can be determined from the LEDs on the front of the QE71.

- ① If the TEST LED is turned off, then the RAM test is completed.
- ② The test results can be checked using the TEST ERR.'s LED.
 - When normal The LED is turned off
 - When error The LED is lit
- ③ The following can be suspected as causes of errors.
 - QE71 hardware error
 - RAM error

Operation after the test is completed

The PLC CPU can be reset after the on-line mode or another test mode is switched using the operation mode setting switch on the front of the QE71.

Point

When there is an error for the test results of the RAM test shown in this item, reconduct the same test.

If an error occurs a second time, then a QE71 hardware error can be suspected. For details regarding troubles, please consult with your nearest branch or agent.

4.6.3 ROM Test

This section explains the ROM test that is used to check the QE71's ROM.

The ERROR LED of the QnACPU may flicker during the ROM test, but this is not an error.

ROM test method

- ① Set the operation mode setting switch on the front of the QE71 to the 4 position.
- ② Set the PLC CPU's RUN/STOP key switch to the STOP position.
- ③ When the PLC CPU is reset, the ROM test will begin.

Test results

The test results can be determined from the LEDs on the front of the QE71.

- ① If the TEST LED is turned off, then the ROM test is completed.
- ② The test results can be checked using the TEST ERR.'s LED.
 - When normal The LED is turned off
 - When error The LED is lit

- ③ The following can be suspected as causes of errors.
- QE71 hardware error
 - ROM error

Operation after the test is completed

The PLC CPU can be reset after the on-line mode or another test mode is switched using the operation mode setting switch on the front of the QE71.

Point

When there is an error for the test results of the ROM test shown in this item, reconduct the same test. If an error occurs a second time, then a QE71 hardware error can be suspected. For details regarding troubles, please consult with your nearest branch or agent.

4.6.4 EEPROM Test

This section explains the EEPROM test used to check the QE71's EEPROM.

The ERROR LED of the QnACPU may flicker during the EEPROM test, but this is not an error.

Test method

- ① Set the operation mode setting switch on the front of the QE71 to the 5 position.
- ② Set the PLC CPU's RUN/STOP key switch to the STOP position.
- ③ When the PLC CPU is reset, the EEPROM test will begin.

Test results

The test results can be determined from the LEDs on the front of the QE71.

- ① If the TEST LED is turned off, the EEPROM test is completed.
- ② The test results can be checked using the TEST ERR.'s LED.

When normal The LED is turned off

When error The LED is lit

- ③ The following can be suspected as causes of an error.
 - QE71 hardware error
 - EEPROM error
 - EEPROM check sum error

Operation after the test is completed

The PLC CPU can be reset after the on-line mode or another test mode is switched using the operation mode setting switch on the front of the QE71.

Point

- (1) To prevent the contents of the EEPROM from being destroyed, absolutely do not turn off the power or reset the module during the EEPROM test.
- (2) When trouble occurs, use the sequence program at Item 5.8 to write the setting values (parameters) in the EEPROM, and then reconduct the EEPROM test. (This will conduct a recovery in the case of a check sum error)
If an error occurs a second time, then a QE71 hardware error can be suspected.
For details regarding troubles, please consult with your nearest branch or agent.

4.7 Connecting to the Network

This section explains the method for connecting the QE71 to the network.

4.7.1 Connection Precautions

1 Installing

- ① Sufficient safety precautions are required when installing network. Consult with a specialist when installing connection cable terminal processing or trunk line cables, etc.
- ② Use a connection cable that meets the standard shown in Item 2.3.
The allowable bending radius for coaxial cables is set. When bending coaxial cables to connect them, a space that is larger than the coaxial cables' allowable radius is required. For information regarding the coaxial cables' allowable bending radius, please consult the cable manufacturer.
- ③ When connecting the QE71 to a 10BASE2 or a 10BASE5, it is necessary to connect a terminator at both ends of the line (both are 50 Ω).
 - Connect a terminator for a 10BASE2/10BASE5 matching the type of the line on the QE71 side (both are 50 Ω).
 - For the connection of terminators on the remote node side, connect them by referring to the instruction manual of the remote node. (Do not connect terminators if termination is set by means of terminal setting.)
- ④ When the A1SJ71QE71N-B5 is in use and the external power supply side of the power supply source for the transceiver is handling the FG signal, ground the FG signal on the external power supply side.

2 Compliance with the EMC Directive and the Low-Voltage Directive

To comply with the EMC Directive and the Low-Voltage Directive by incorporating a QE71 into the customer's product, install a ferrite core according to the method shown in (4) below.

(Also refer to the "Conformation to the EMC Directive and Low Voltage Instruction" (section before Chapter 1).)

3 Countermeasures against high-frequency noise

The following countermeasures are available for communication errors that may occur due to high-frequency noise in an installation environment:

- ① Install a ferrite code according to the method shown in (4) below.
- ② Make the cable as short as possible.
- ③ Use the following cable for connection to a 10BASE-T.

Model name	Cable	Category
AJ71QE71N3-T, A1SJ71QE71N3-T	Shielded twisted cable (STP)	3, 4, 5
AJ71QE71N-T, A1SJ71QE71N-T	Unshielded twisted cable (UTP)	3, 4, 5

- ④ Use a double-shielded coaxial cable when connecting a QE71 to a 10BASE2.

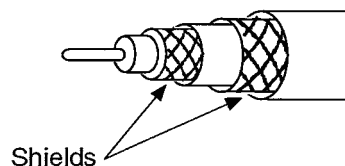

- ⑤ When connecting a QE71 to a 10BASE5/10BASE2, ground the shields of the coaxial cable on both the self station side and the connection counterpart device side. (Ground at a location near the connector.)
- * When using a double-shielded coaxial cable, ground the outer shield.
 - * For grounding on the PLC side, refer to Chapter 3, "EMC Directive and Low-Voltage Instruction" of the user's manual (hardware edition) of the CPU module used.
- ⑥ To perform TCP/IP communication, increase the number of communication retry count. (Specify it in the initial processing of the QE71. Refer to *1 at the end of Item 5.2.2.)

4

Ferrite core installation

- ① Install a ferrite core (*1) at the QE71 side and at the external device side/transceiver side of the AUI cable.
- *1: ZCAT 2032-0930 manufactured by TDK Corporation is usable.
- ② Ferrite cores should be installed as follows for connecting to a network via the 10BASE5.

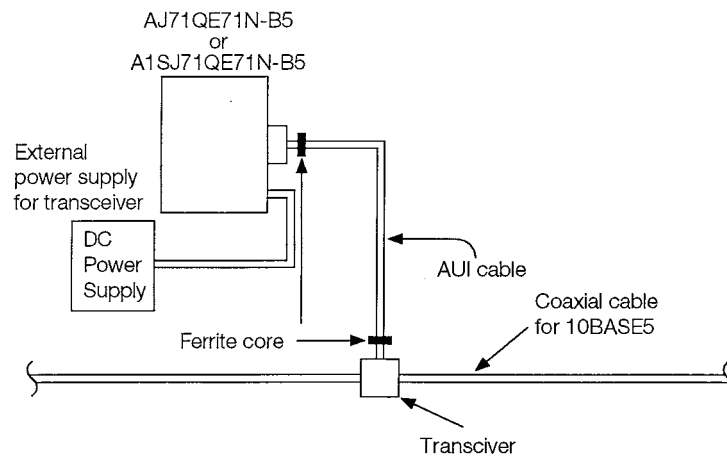
**CAUTION**

- Do not bundle the control wires and the communication cables with the main circuit and the power wires, and do not install them close to each other. They should be installed 100mm (3.9 inch) or more from each other. Not doing so could result in noise that would cause erroneous operation.
- Do not connect the AUI cables when the module installation station's power is turned on.
- The communication cables and power cables connected to the module must always be set in ducts or secured using clamps. If the cable is not placed in a duct or not secured with clamps, it may be loosened, relocated or pulled unintentionally, causing malfunctions or damage to the module and cable.
- When removing communication cables or power cables connected to the module, do not pull directly on the cable. For cables with connectors, remove them by holding the connector that connects to the module. For cables without connectors, remove them after loosening the screws in the connection area. If the cable is pulled while it is connected to the module, it may cause a malfunction or damage to the module and cable.

4.7.2 Connecting to 10BASE5

This section explains the method for connecting QE71 to the 10BASE5 network.

(Applicable modules in the explanation: AJ71QE71N-B5, A1SJ71QE71N-B5)

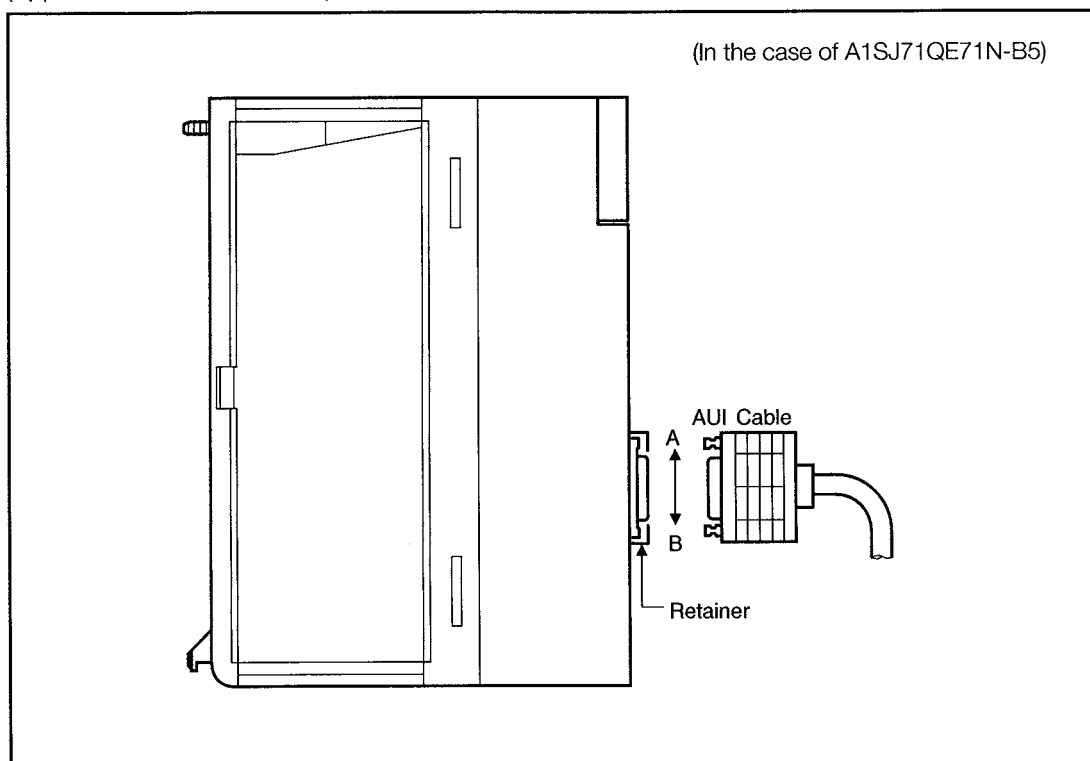

Fig 4.1 AUI Cable Connection Diagram

Method for connecting to the AUI Cable

- (1) Slide the retainer in the A direction as shown in Fig 4.1.
- (2) Push the AUI cable connector to the back.
- (3) Slide the retainer in the B direction as show in Fig 4.1.
- (4) Check that the AUI cable is locked.
- (5) Turn on the transceiver's power. (*1)

*1 Please use transceivers that have functions that are generally called SQETEST or Heartbeat (transceiver function that uses a signal to check if the transceiver is operating correctly after transmission).

CAUTION • Do not connect the AUI cable when the module installation station's power is turned on.

Point

- (1) When connection to the network is made using the 10BASE5, if countermeasures against high-frequency and noise generated in the installation environment of QE71 is necessary, attach a ferrite core to the AUI cable to eliminate these effects.
Refer to (4) in Item 4.7.1 .
- (2) For the devices that are required for connecting a QE71 to a 10BASE5 and examples of system configuration, refer to (1) in Item 2.3.

4.7.3 Connecting to 10BASE2

This section explains the method for connecting the QE71 to the 10BASE2 network.

(Applicable modules in the explanation: AJ71QE71N-B2, A1SJ71QE71N-B2)

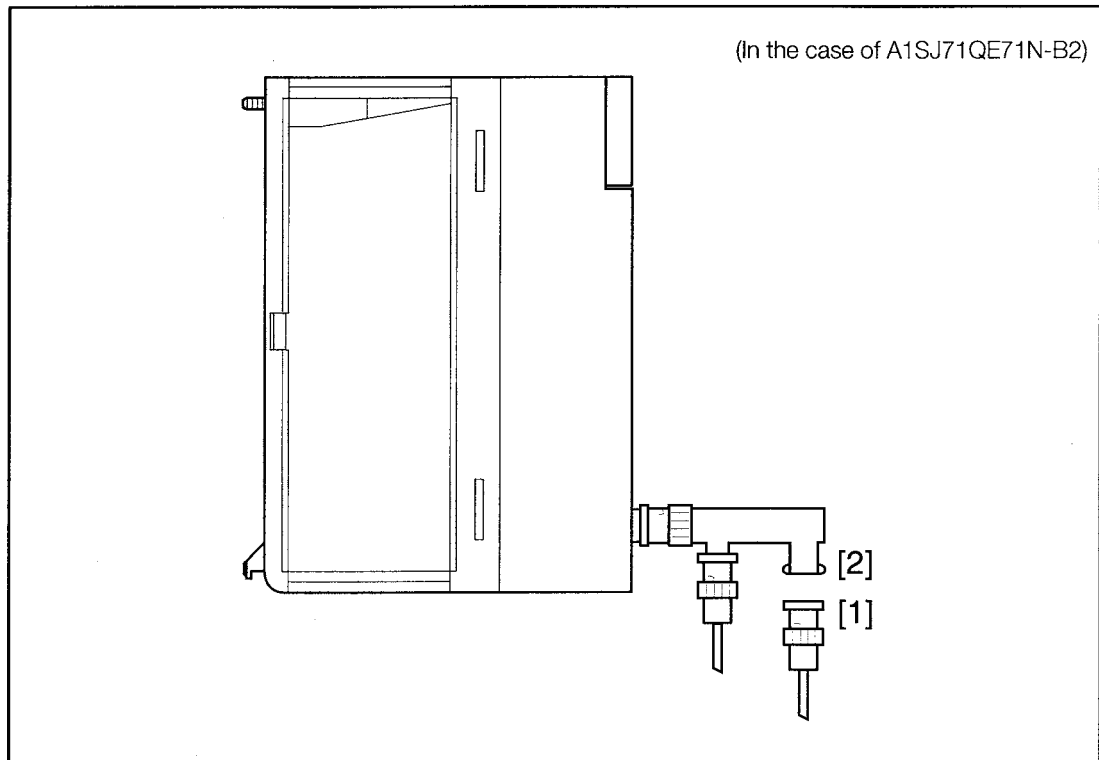

Fig 4.2 10BASE2 Coaxial Cable Connection Diagram

10BASE2 Coaxial cable connection method

- (1) As shown in Fig 4.2, line up and push in the lip [2] into the groove [1].
- (2) Turn the connector 1/4 rotation to the right while pushing it in.
- (3) Turn the connector until it locks.
- (4) Check that the connector is locked.

Point

For the devices that are required for connecting a QE71 to a 10BASE2 and examples of system configuration, refer to (2) in Item 2.3.

Remarks

Coaxial cable connector connection

This section explains the method for connecting the BNC connector (coaxial cable connector plug) to the cable.

(1) BNC connector and coaxial cable configuration

Fig 4.3 shows the BNC connector and coaxial cable configuration.

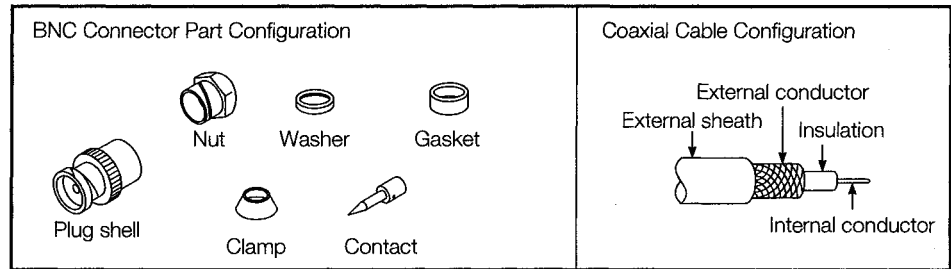
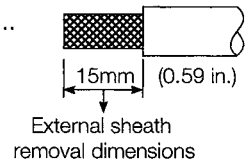

Fig 4.3 BNC Connector and Coaxial cable configuration

(2) Method for connecting the BNC connector and the coaxial cable

The following shows a method for connecting the BNC connector to the coaxial cable.

(a) Remove the coaxial cable's external sheath as shown in the drawing at right. Be careful not to damage the external conductor.



(b) Place the nut, washer, gasket, and clamp on the coaxial cable as shown in the drawing at right, and then wrap the external conductor.

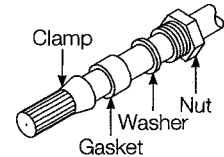

(c) Cut the external conductor, insulator, and internal conductor to the dimension as shown in the drawing at right. However, to cut the external conductor to the same dimension as the clamp's tapered portion, place the clamp on before cutting.

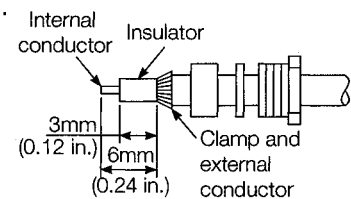

(d) Solder the contact to the internal conductor.

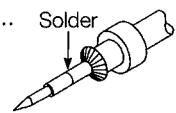

(e) Insert the contact assembly in (d) into the plug shell, and screw on the plug shell nut.

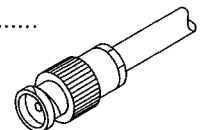

Point

Take the following precautions when soldering the contact to the internal conductor.

- (1) Be sure that the solder does not creep up the soldered area.
- (2) Be sure that there are no gaps in or biting into the contact and cable's insulation.
- (3) Quickly do the soldering to prevent the insulation from deforming.

4.7.4 Connecting to 10BASE-T

This section explains the method for connecting the QE71 to the 10BASE-T network.

(Applicable modules in the explanation: AJ71QE71N3-T, AJ71QE71N-T, A1SJ71QE71N3-T, A1SJ71QE71N-T)

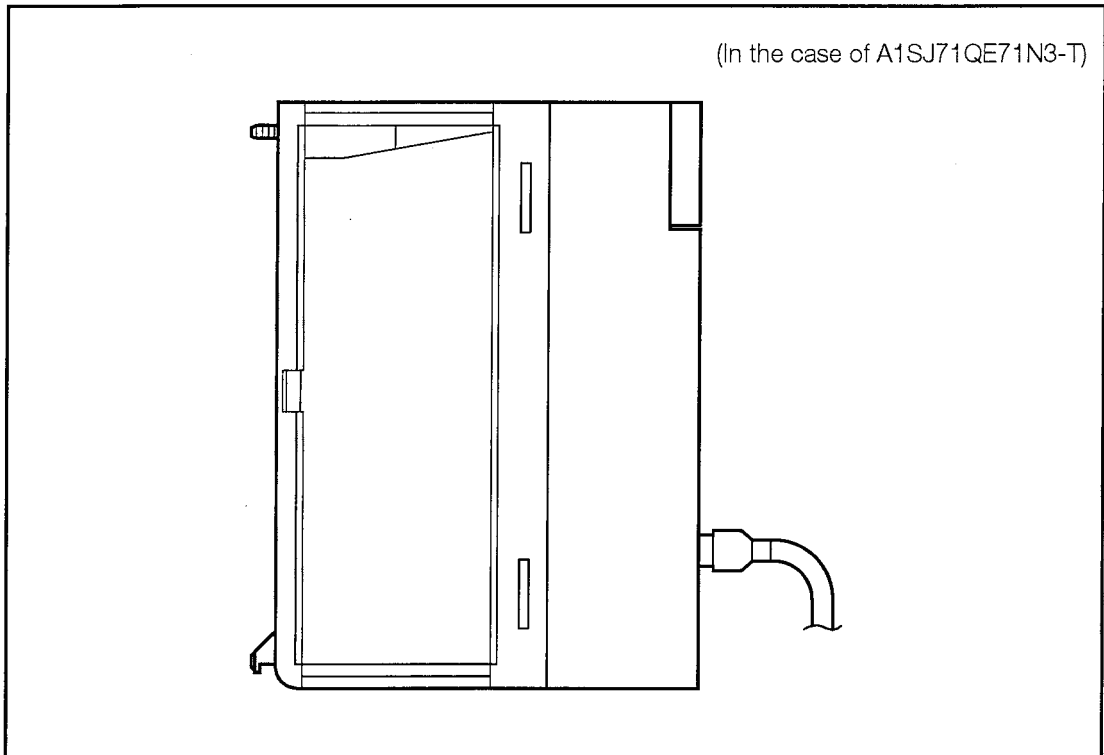

Fig 4.4 10BASE-T Twisted-Pair Cable Connection Diagram

Method for connecting the 10BASE-T twisted-pair cable

- (1) Connect the twisted-pair cable to the hub.
- (2) Connect the twisted-pair cable to the QE71.

Point

- (1) The QE71 operates in the half duplex communication mode of the 10BASE-T.
- (2) For the devices that are required for connecting the QE71 to the 10BASE-T and examples of system configuration, refer to (3) in Item 2.3.

4.8 Parameter Types and Parameters that can be Set Up by GPPW

To use a QE71, it is necessary to set up the parameters for various processing and for functions to be used in the buffer memory of the QE71.

This section explains the types of the QE71 parameters and how to set up these parameters.

1 Types of the QE71 parameters

The following shows the types of the parameters necessary to use the QE71.

The contents of the columns in the table below are as follows:

- "Buffer memory" column: Indicates the buffer memory of the QE71 where the parameters are stored.
- "GPPW setup" column: Indicates the parameters that can be set up by a program such as GPPW.
- "EEPROM registration" column: Indicates the parameters that can be registered in EEPROM of the QE71.

(Address)	Buffer memory	GPPW setup (*1)	EEPROM registration	Detailed explanation
0 to 1FH (0 to 31)	Initial processing parameter setting area (32 words)	Can be set up	Can be registered	Item 5.2.2
20 to 5FH (32 to 95)	Exchange parameter setting area (64 words)	Cannot be set up		Item 5.5.1
67H (103)	Exchange instruction area during STOP (1 word)	up		Chapter 16
200 to 201H (512 to 513)	Subnet mask setting area (2 words)	Can be set up		Item 11.2
202 to 225H (514 to 549)	Router relay parameter setting area (36 words)			Item 12.4
228 to 3AAH (552 to 938)	Station No. <-> IP information setting area (387 words)			Item 15.3.4
3B0 to 3BFH (944 to 959)	FTP parameter setting area (16 words)			Item 13.3

*1 For more information on the parameter setting areas that can be set up by a program such as GPPW, refer to Item 3.7.2.

The setting values of the areas marked by "<Pa>" at the left side of the "default value" column in the table shown in Item 3.7.2 can be set up by a program.

2 Setup methods of the QE71 parameters

The QE71 parameters can be set up in either of the following methods:

- ① Use a sequence program.
- ② Use a program such as GPPW (refer to (4) in Item 2.2).

Load the parameters that have been set up by GPPW or other program into the QnACPU of a station in which a QE71 is installed. When that station is restarted, the QE71 parameters loaded into the QnACPU will be written into the buffer memory of the QE71.

* Setup from the sequence program as described in ① above is not required for the parameters set up with GPPW or other program.

3 GPPW parameter setting screen for the QE71

The following figure shows the screen for setting parameters for the QE71 using GPPW.

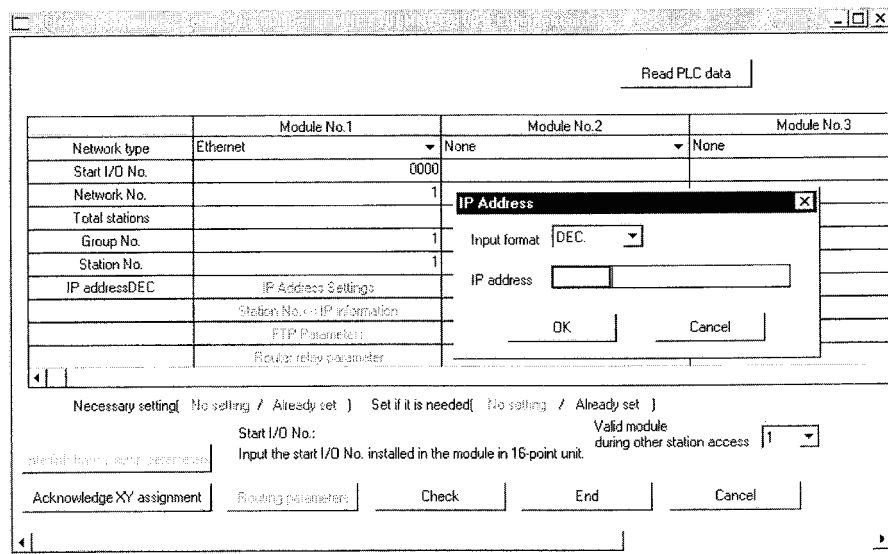

Setting screen	Setting item	Description and target function of the setting	Reference section for the details of setting	
Setting the number of MNET(II) MNET/10(H) Ethernet cards	Network type	Set the Ethernet parameters for accessing remote stations via the QE71. •MELSECNET/10 relay exchange •Data link command exchange	Item 15.3.2	
	Network No.			
	Group No.			
	Station No.			
IP address settings	IP address	Set the IP address of the local station.	Item 5.2.2	
Setting the Ethernet Station No. <-> IP information (Station No. <-> IP information)*1	Station No. <-> IP information system	Set the Station No. <-> IP information parameters for accessing remote stations via the QE71. •MELSECNET/10 relay exchange •Data link command exchange	Item 15.3.4	
	Net mask pattern			
	Conversion setting			Network No.
				Station No.
Setting the Ethernet FTP parameters (FTP parameters)*1	FTP	Set the FTP parameters for using the file transfer function. •File transfer (FTP server) function	Item 5.2.2	
	Log-in name		Item 13.3	
	Password (Current/New)			
	Command input monitoring timer			
Setting the Ethernet router relay parameter (Router relay parameter)*1	Router relay function	Set the router relay parameters for communicating with remote nodes via a router. •Router relay exchange function	Item 5.2.2	
	Sub-net mask pattern		Item 11.2	
	Default router IP address		Item 12.4	
	Router information			Sub-net address Router IP address
Setting the MNET(II) MNET/10(H) Ethernet routing information (Routing parameters)*1	Target network No.	Set the routing parameters for accessing remote stations via the QE71. •MELSECNET/10 relay exchange •Data link command exchange	Item 15.3.3	
	Relay network No.			
	Relay Station No.			
	Via Station No.			

*1 Information given in () refers to the display in the "Setting the number of MNET (II) MNET/10 (H) Ethernet cards" screen.

Point

- (1) When setting QE71 parameters with GPPW, set up the parameters of all installed QE71s (function version B).
- (2) For parameter setup to the Q4ARCPU (with added function), see Item (7) of this section.
- (3) For the parameters that cannot be set up by a program such as GPPW, use a sequence program to set them up.
- (4) The parameters that have been set up by a program such as GPPW will be valid by loading them into the QnACPU and then restarting the QnACPU.

4 Setting up the parameters by a program

The following table shows the programs by which the parameters required to use the functions of the QE71 listed below can be set up.

As long as the versions of programs are as indicated in the table below or later than these versions (left side: hardware version, right side: software version), the programs can set up the parameters required to use the applicable functions of the QE71.

Function	Parameter setup program			
	GPPQ			GPPW
	SW0	SW1	SW2	SW1 or later
File transfer	(Cannot be set up)		A A	A A
Data link command exchange	(Cannot be set up)		A A	A A
MELSECNET/10 relay exchange	(Cannot be set up)		A A	A A
Connection of GPPW to QE71 (Ethernet connection)	(Ethernet connection is not allowed)			A A
Access to remote station's PLC from MELSOFT product via QE71 (*1)	(Cannot be set up)			A A

*1 Access to a remote station's PLC can be performed via the QE71 depending on the product. For more details, refer to the manual of each product.

GPPW: SW2D5C/F-GPPW-E or later

MX Component: SW0D5C-ACT-E or later

5 Relationships between the functions of the QE71 and the required parameters

The following table shows the relationships between the functions of the QE71 and the parameters that must be set up in order to use various functions of the QE71.

Functions Parameters	Data communication functions								
	Fixed buffer exchange		Random access buffer exchange	Read/write data in the PLC CPU		Data link command exchange	File transfer (FTP)	MELSEC NET/10 relay	Router relay
	With procedure	Without procedure		QE71 command	E71 command				
Initial processing parameters									
Local station IP address	○	○	○	○	○	○	○	○	○
Special function settings	×	×	×	○	×	○	○	○	○
Various timer values	○	○	○	○	○	○	○	○	○
Automatic open UDP port No.	×	×	×	○	×	×	×	×	×
Exchange parameters									
Usage applications									
Bit 0 (Application for burred)	○	○	×	×	×	×	×	×	×
Bit 1 (Existence check)	△	△	△	△	△	×	×	×	×
Bit 7 (Pairing)	△	△	×	×	×	×	×	×	×
Bit 8 (Communication format)	○	○	○	○	○	×	×	×	○
Bit 9 (Exchange procedure)	○	○	×	×	×	×	×	×	×
Bit 14 · 15 (*1)	○	○	○	○	○	×	×	×	○
Exchange address									
QE71 port No.									
Remote node IP address	○	○	○	○	○	×	×	×	×
Remote node port No.	(*)	(*)	(*)	(*)(*2)	(*)				
Remote node Ethernet address									
FTP parameters	×	×	×	×	×	×	○	×	×
Ethernet parameters	×	×	×	×	×	○	×	○	×
Routing parameters	×	×	×	×	×	△	×	△	×
Conversion method (*3)	×	×	×	×	×	○	×	○	×
Router relay parameters	×	×	×	×	×	×	×	×	○

○ : Setting (default value/changed value) is necessary.

△ : Setting (default value/changed value) is necessary when the applicable function is used.

×

*1 Set each parameter by an open method at open processing when connecting a communication line.

Communication format open method		TCP				UDP	
		Active		Passive		Remote node ARP functions	
		Remote node ARP functions		Unpassive	Full passive		
		Yes	No			Yes	No
Exchange address	QE71 port No.	○	○	○	○	○	○
	Remote node IP address	○	○	×	○	○	○
	Remote node port No.	○	○	×	○	○	○
	Remote node Ethernet address	○**	○	×	×	○**	○

** Please make the default value (FFFFFFFFFFFFH).

*2 Setting is only required when opened by the sequence program.

*3 This includes the Station No. <-> IP information parameter.

6 Registering the parameters into the EEPROM of the QE71

The parameters written into the buffer memory of the QE71 can be registered in the EEPROM of the QE71. By registering them, they can be used as default values when the QE71 is started next or subsequent time.

For more details on how to register the parameters to the EEPROM of the QE71, refer to Item 4.9.

Point

To operate the QE71 by using the parameters registered in EEPROM, set the exchange condition setting switch (SW3: automatic startup mode) of the QE71 to ON, and then start the QnACPU of a station in which the QE71 is installed.
When starting the QnACPU of the station in which the QE71 is installed in this method, the parameters for the QE71 loaded into the QnACPU will become unnecessary.

7 Support for the Q4ARCPU (product with added functions)

The following explains the case when QE71s are used together with Q4ARCPUs for which function addition has been implemented and which have the date of manufacturing beginning with "0012" (last two digits of the year + two-digit month) and the software version of B or later.

* Also refer to the user's manual (detailed edition) for the Q4ARCPU with added functions in regard to IB-66685-B or later product.

(a) Description of added functions

- ① Access to the Q4ARCPU from GPPW via Ethernet connection
- ② Access to a remote station's PLC via a remote Ethernet or the MELSECNET/10 (using the MELSECNET/10 relay exchange function of the QE71).

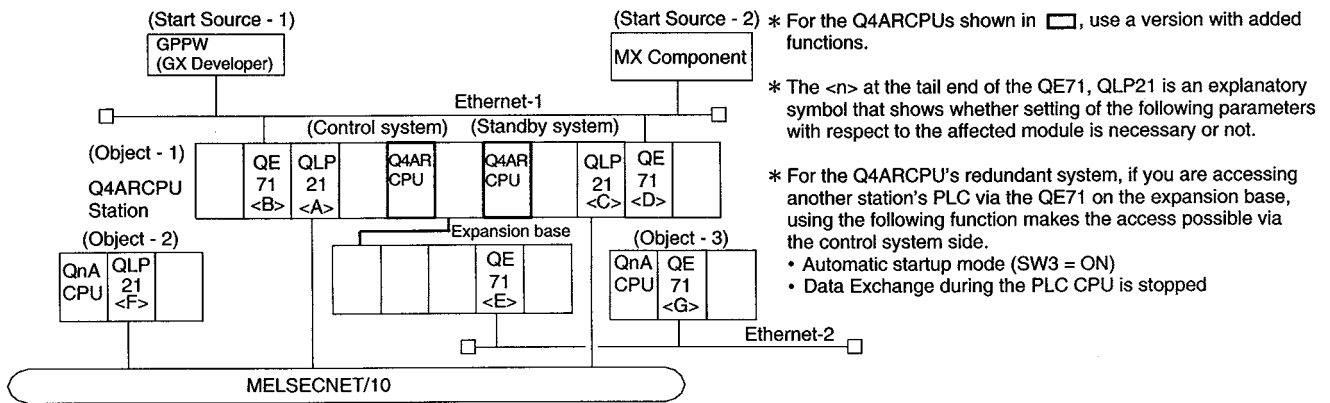

* For the Q4ARCPUs shown in , use a version with added functions.

* The <n> at the tail end of the QE71, QLP21 is an explanatory symbol that shows whether setting of the following parameters with respect to the affected module is necessary or not.

* For the Q4ARCPU's redundant system, if you are accessing another station's PLC via the QE71 on the expansion base, using the following function makes the access possible via the control system side.

- Automatic startup mode (SW3 = ON)
- Data Exchange during the PLC CPU is stopped

		Start source		Object-1	Object-2	Object-3
When a Q4ARCPU with added functions and a QE71 are used	Start Source-1	GPPW	When Version 6.05F or later product is used.		●	
	Start Source-1	GPPW	When Version 6.04E or earlier product is used.		×	
When a Q4ARCPU without added functions and a QE71 are used	Start Source-2	MX Component	When SW0D5C-ACT-E or later product is used.	○		●
	Start Source-1	GPPW	When Version 6.05F or later product is used.		×	
When a Q4ARCPU without added functions and a QE71 are used	Start Source-1	GPPW	When Version 6.04E or earlier product is used.		×	
	Start Source-2	MX Component	When SW0D5C-ACT-E or later product is used.	○ (Only TCP/IP can be used)		×

●: Can be accessed after function addition ○: Can be accessed before function addition ×: Cannot be accessed

(b) Network parameter settings by GPPW for using added functions (for Ethernet)

Using the system configuration shown in the above figure as an example, the network parameters required for using added functions and the modules for which these parameters must be set up are shown below.

Network parameter		Function	Access to the Q4ARCPU from GPPW via Ethernet connection	Exchange (access to the QnACPU) using the QE71 MELSECNET/10 relay exchange function
For QE71 (*1)	Setting the number of MNET/10 Ethernet cards (*2)		<A> <E>, <C> <D> <E>, <F>, <G>	
	IP address setting (*2)		 <E>, <D> <E>, <G>	
	Station No. <-> IP information		, <D>	 <E>, <D> <E>, <G>
For network	Routing parameters (*3)		—	(Setting is not necessary with this system configuration.)

- *1 Set up any of the QE71 parameters other than above using a sequence program.
(If any of the QE71 parameters other than above is set up using GPPW, an error will occur when starting the Q4ARCPU.)
- *2 In a duplex system, if a QE71 is installed in each location of the control system and the standby system in the basic base and both are connected to the same Ethernet, use different station numbers (set the station numbers in the "setting the number of MNET/10 Ethernet cards" network parameter) and IP addresses for these QE71s.
If they are connected to different Ethernets, the same station number and IP address can be used for both QE71s.
- *3 When accessing a remote station via a remote Ethernet or a MELSECNET/10, also set up the routing parameters.
For more information on the routing parameters, refer to the MELSECNET/10 Reference Manual.

Important

- (1) Compatibility with duplex Q4ARCPU systems
The QE71 is not compatible with duplex Q4ARCPU systems (see Item (2) in Section 2.5.3).
If the QE71 is used in a duplex Q4ARCPU system, the functionality will be limited to when the QE71 is used together with the Q4ACPU.
- (2) When the QE71 is installed in the basic base unit in a duplex Q4ARCPU system
For the input/output signal range for the QE71, do not set tracking.
If tracking is set, the QE71 will not operate normally.
- (3) When the QE71 is installed in the extension base unit in a duplex Q4ARCPU system
For the output signal range for the QE71, set tracking.
If tracking is not set, the QE71 will not operate normally.

4.9 Registering Parameters (Setting Values) in the EEPROM

The setting values (parameters) for the buffer memory can be registered in the QE71's EEPROM, and these can be used as the default values when the QE71 is booted up. Following is an explanation of the method for registering parameters in the EEPROM.

4.9.1 Registering Parameters in the EEPROM

About the parameters that can be registered in the buffer memory, refer to "EEPROM registration" in the table shown in Item 4.8 (1). Conduct registration to the EEPROM after checking that data exchange with the remote node is normal. Registering parameters to the EEPROM makes the sequence program that changes the buffer memory default values unnecessary.

Remarks

The following explains how setting values are stored into the buffer memory of the QE71 when they are registered in the EEPROM of the QE71 and when they are loaded as parameters into the QnACPU.
 When starting the QE71, the parameters are written into the buffer memory of the QE71 in the order shown in the figure below.

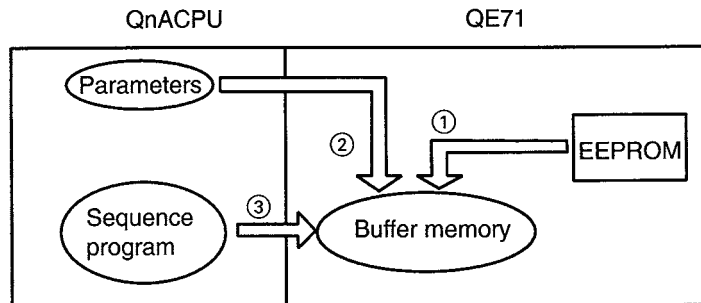

- * First, the setting values registered in the EEPROM are over-written into the buffer memory. Next, the parameters loaded into the PLC CPU are over-written into the buffer memory. Then, the QE71 will start.
- If the parameters for the QE71 have not been loaded into the PLC CPU, step ② shown in the above figure will be skipped.
- If there is no sequence program for writing the setting values into the buffer memory of the QE71, step ③ shown in the above figure will be skipped.

4.9.2 I/O Signal and Buffer Memory for Handshaking with the PLC CPU

This section explains the I/O signal and buffer memory for handshaking with the PLC CPU when buffer memory setting values (parameters) are registered to the EEPROM and when the parameters registered in the EEPROM are read to the corresponding buffer memory.

1 I/O signal for handshaking with the PLC CPU

	I/O signal	Signal name	Device that turns on and off		Timing
			CPU	QE71	
Setting value registration	X1E	EEPROM write end		○	Write end
	Y11	EEPROM write request	○		
Setting values read	X1D	EEPROM read end		○	Read end
	Y10	EEPROM read request	○		

2 Buffer memory

The area is used when the buffer memory parameters are registered in the EEPROM, and when the parameters registered in the EEPROM are read to the corresponding buffer memory is shown below. For details regarding the sequence from EEPROM registration state to the EEPROM write results, refer to the explanation of exchange state storage area in Item 5.6.1.

(Address)	Buffer memory	Default value
68H (104)	EEPROM parameter portion specification (1 word)	0H (0)
70H (112)	EEPROM registration state (1 word)	AAAH (2730)
71H (113)	Parameter use state (1 word)	0H (0)
72H (114)	EEPROM read results (1 word)	0H (0)
73H (115)	EEPROM write results (1 word)	0H (0)

- (a) EEPROM parameter portion specificationAddress 68H (104)
Checks the parameter registered in the EEPROM, registers and clears parameters in the EEPROM, and specifies the parameter types when reading from the buffer memory is conducted.

Remarks

An error results when parameters that are not normally registered are specified when read or clear are conducted.

b15	b14	b13	b12	b11	b10	b9	b8	b7	b6	b5	b4	b3	b2	b1	b0
0	⑦	0	⑥	0	⑤	0	④	0	③	0	②	0	①	0	0

[Parameter specification for ① to ⑥]

Specifies the parameters to be used when registration, clear, and read are conducted.

- 0 : Corresponding parameters are not involved
- 1 : Corresponding parameters are involved

- ① Initial processing parameters
- ② Exchange parameters
- ③ Router relay parameters (including subnet mask fields)
- ④ Station No. <-> IP information parameters
- ⑤ FTP parameters
- ⑥ Exchange instruction parameters during STOP

[EEPROM clear instruction for ⑦]

Specifies which of the options is to be performed when registering to/clearing from the EEPROM the parameter values for the target parameters specified in ① to ⑥ above.

- 0 : Registration (write) is conducted.
- 1 : Clear is conducted.

(b) EEPROM registration stateAddress 70H (112)

The following values (corresponding to bit portion) are stored as the parameter registration states in the EEPROM.

- 00 : No parameter registration
- 01 : Parameter registration (registered parameter was an error)
- 10 : Parameter registration (registered parameters were normal)

b15	b14	b13	b12	b11	b10	b9	b8	b7	b6	b5	b4	b3	b2	b1	b0
0			⑥	⑤	④	③	②	①							

- ① Initial processing parameters
- ② Exchange parameters
- ③ Router relay parameters (including subnet mask fields)
- ④ Station No. <-> IP information parameters
- ⑤ FTP parameters
- ⑥ Exchange instruction parameters during STOP

(c) Parameter usage stateAddress 71H (113)

The read state for each parameter when the parameters registered in the EEPROM are read to the buffer memory are stored as the following values (corresponding bit portion).

- 00 : No read /No parameter registration
- 01 : Read (read values are not set because of error end)
- 10 : Read (normal end)

Each parameter read state's storage position is the same as the position shown in (b) EEPROM registration state.

(d) EEPROM read resultsAddress 72H (114)

The read results registered in the EEPROM are stored as binary values.

0 : Normal end

Other than 0 : Error end (Refer to Chapter 17 for details regarding error codes)

Check the parameter read states using the parameter usage state shown in (c) above.

(e) EEPROM write resultsAddress 73H (115)

The results of the user registration write of buffer memory parameters to the EEPROM are registered as binary values.

0 : Normal end

Other than 0 : Error end (Refer to Chapter 17 for details regarding error codes.)

4.9.3 Registering, Reading, and Clearing of Parameters

This section explains the method for registering, clearing, and reading to buffer memory setting values (parameters) to the QE71's EEPROM from the PLC CPU. For information regarding registration and reading from a remote node, refer to Item 10.7.

1 Registration and clearing to the EEPROM

(Registration/clearing procedures)

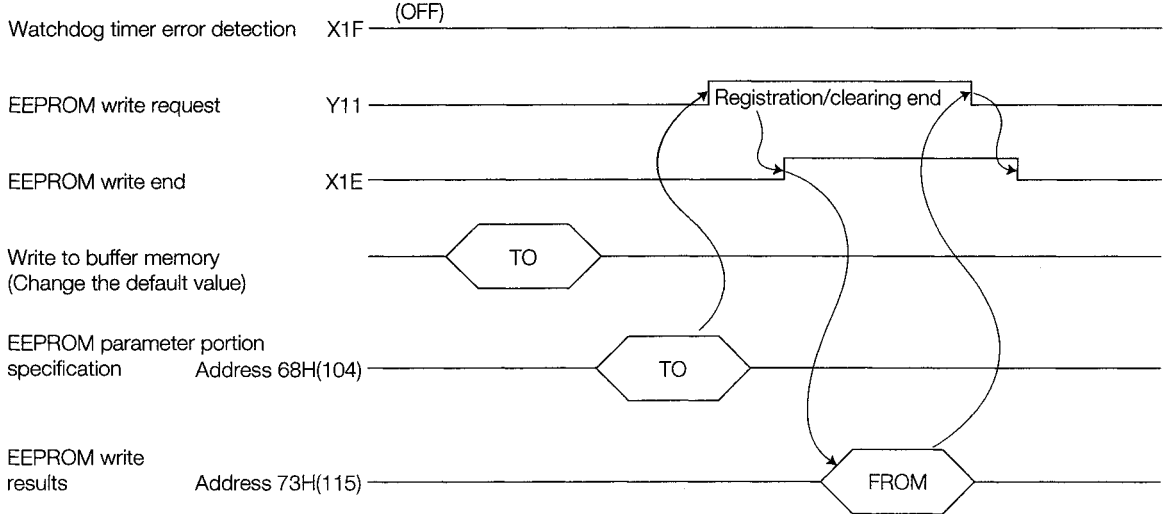

(Example registration program) ----- QE71 I/O signal (X/Y0 to 1F)

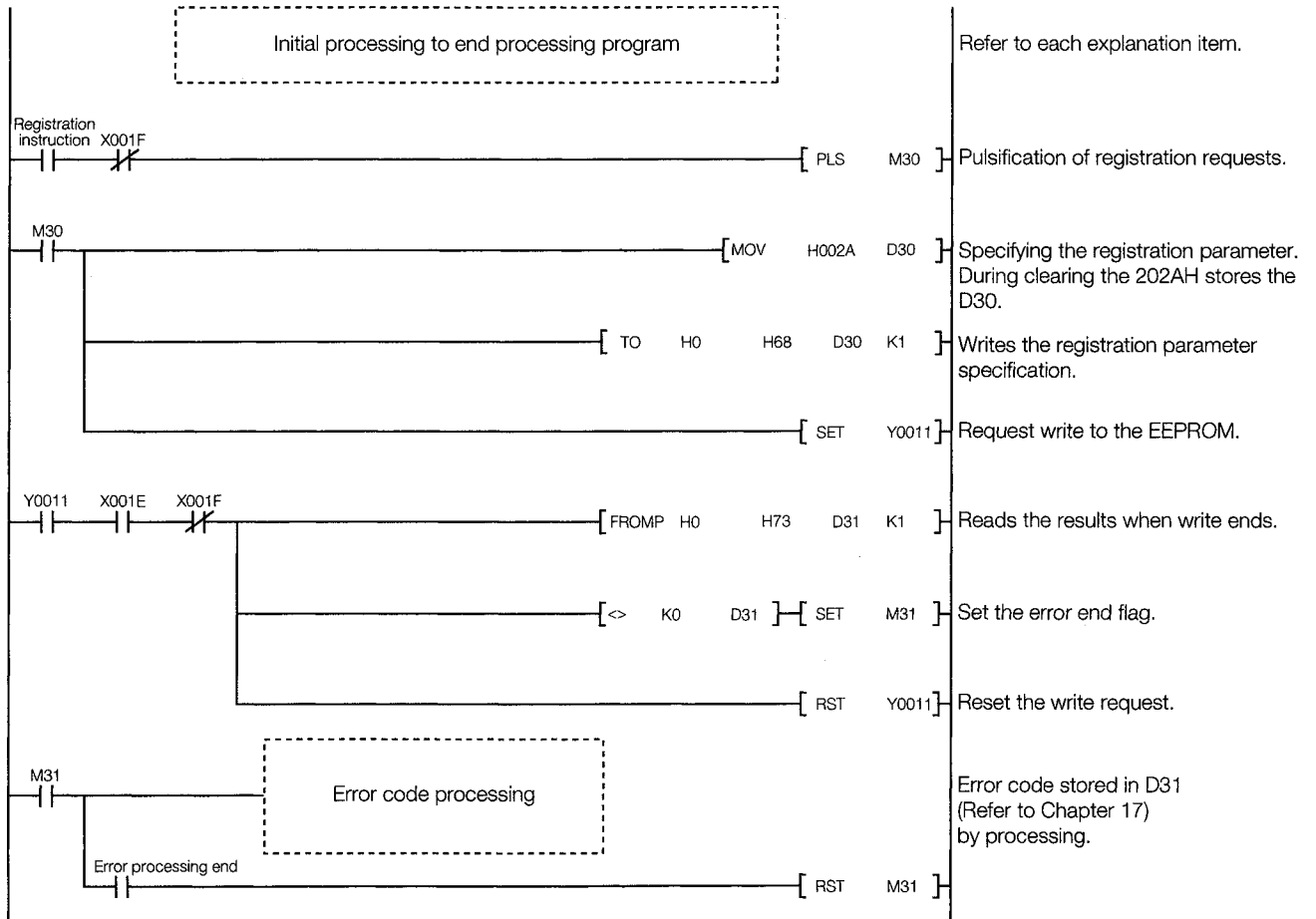

2 Method for reading from EEPROM

In the EEPROM it is possible to read only the data that was correctly written (registered). An error will occur when there is a read request for error data that was written.

(Read procedure Turn OFF the exchange condition setting switch SW3)

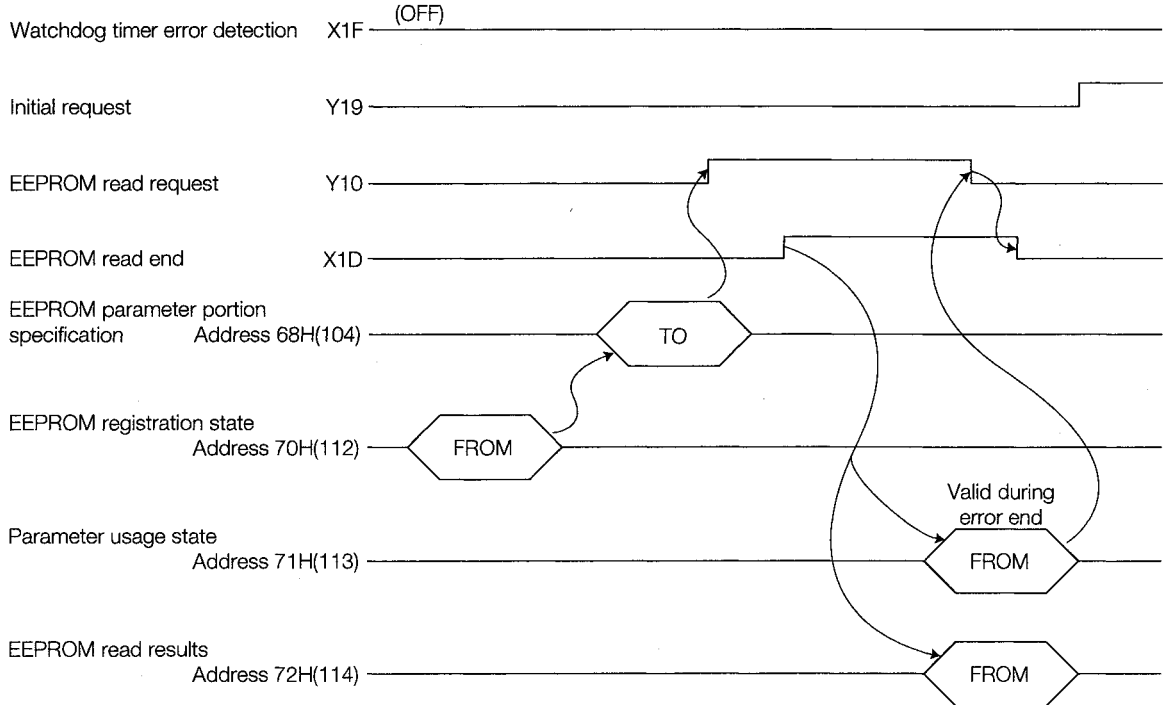

(Example read program) QE71 I/O signal (X/Y0 to 1F)

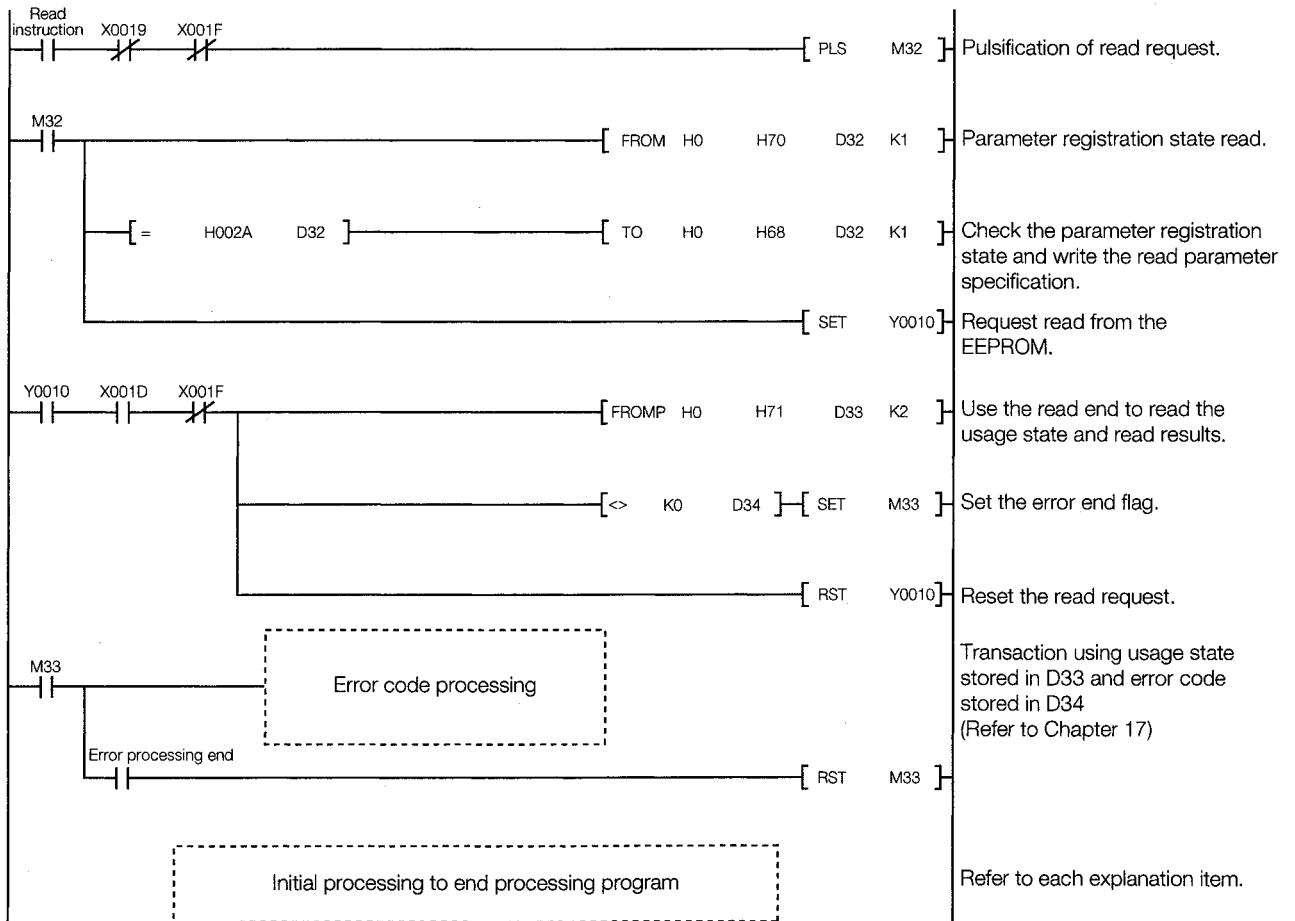

4.10 Loopback Test

The loopback test is a function that tests whether exchange is conducted normally between a node and the local station QE71. When a loopback test is conducted, the data transmitted from the remote node is then retransmitted as is by the QE71 as a response to the originating station. Conduct the loopback test in accordance with Item 10.9.

4.11 Maintenance and Inspection

There are no inspection items for the QE71 other than the terminator and checking the cable connections for looseness. In addition to this, to keep the system in good condition at all times and conduct the inspection items contained in the PLC CPU's module's user manual.

**DANGER**

- Do not touch the connector while the power is on. Doing so could cause malfunction.
- Make sure to switch off all phases of the external power supply used by the system before cleaning or re-tightening screws. Otherwise, it will cause failure or malfunctions of the module. If the screws are loose, it may result in fallout, short circuits, or malfunctions. Tightening the screws too far may cause damage to the screw and/or the module, resulting in fallout, short circuits, or malfunctions.

**CAUTION**

- Do not disassemble or modify the modules. Doing so could cause trouble, malfunction, injury, or fire.
- Make sure to switch off all phases of the external power supply used by the system before mounting or removing the module. Otherwise, it will cause failure or malfunction of the module.
- Do not directly touch the module's conductive parts or electronic components. Doing so could cause malfunction or trouble in the module.

Points

- (1) In general, the devices (e.g., QE71, communication board) that are connected to an Ethernet store the Ethernet address of the counterpart device with which they have communicated. Therefore, if these devices are replaced, it is necessary to update the Ethernet address of the local station stored by the communication counterpart device. Since these devices do not immediately update the Ethernet address of the communication counterpart device under normal operating condition, it will lead to a communication error. To prevent it, be sure to restart the QE71 after replacing the communication board/module on the remote node side that has opened a connection with the QE71.
- [Restart procedure on the QE71 side]
- ① End all communications with remote nodes, and close all connections currently open. (Set the open request signal to OFF.)
 - ② After all open completion signals are set to OFF, perform the end processing of the QE71. (Set the initial request signal to OFF.)
 - ③ After the initial normal completion signal is set to OFF, perform the initial processing of the QE71. (Set the initial request signal to ON.)
 - ④ After the initial normal completion signal is set to ON, perform open processing to a remote node with which communication is to be established. (Set the open request signal to ON.)
- (2) If a defective QE71 is replaced, restart the remote node side below in accordance with the specification, and resume data exchange.
- All remote nodes that were communicating with the station in which the replaced QE71 was installed
 - All remote nodes that were communicating with a remote station's PLC via the station in which the replaced QE71 was installed

5. PROCEDURES FOR EXCHANGING WITH REMOTE NODES

This section explains the methods, etc., for registering the QE71 initial processing, communication line open processing with remote nodes, and buffer memory setting values in the EEPROM that are required for summary communication procedures and beginning data communication using the QE71.

5.1 Overview of Exchange Procedures

This section shows the general procedure used to exchange data between the QE71 and a remote node.

To begin data exchange, the initial processing and open processing must be used to connect with the exchange partner and the communication line.

For the QE71, use either the request startup mode or the automatic startup mode to conduct initial processing and open processing. (For information regarding request operation mode and automatic operation mode, refer to Item 5.2)

To end data exchange, conduct close processing and end processing. This disconnects the communication line and ends all exchange processing.

Point

- (1) When conducting either fixed buffer exchange, random access buffer exchange, or reading and writing to the PLC CPU, open processing must be conducted with a remote node to exchange. In addition, all of the above three types of exchange can be conducted with user opened remote nodes.

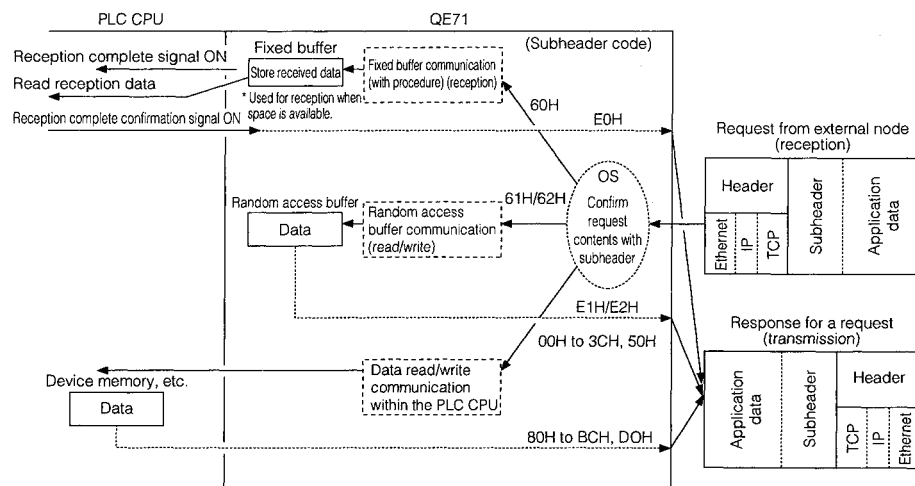

- (2) Open processing can be conducted for a maximum of eight nodes. However, when translating and receiving with the same remote node using a fixed buffer, two fixed buffers are required so the number of nodes to which exchange can be conducted is reduced.
- (3) This explains initial processing and open processing when using the port excuting data exchange after opened by the sequence program.
- When a QE71 installation station's PLC CPU is in the STOP status, the QE71's open request signal (Y8 to YF) and initial request signal (Y19) are also turned off and the line to the remote node is closed.
- When the QE71 installed station's PLC CPU is changed from STOP to RUN, reconduct initialization processing and open processing.
- To continue data exchange after the PLC CPU of the QE71 installed station is set to STOP, use "data exchange function while the PLC CPU is in the STOP status."

1 Exchange procedures during request start mode

Initial processing, open processing, and data exchange sequence programs for the exchange procedure after the QE71's installed station's PLC CPU write processing is completed.

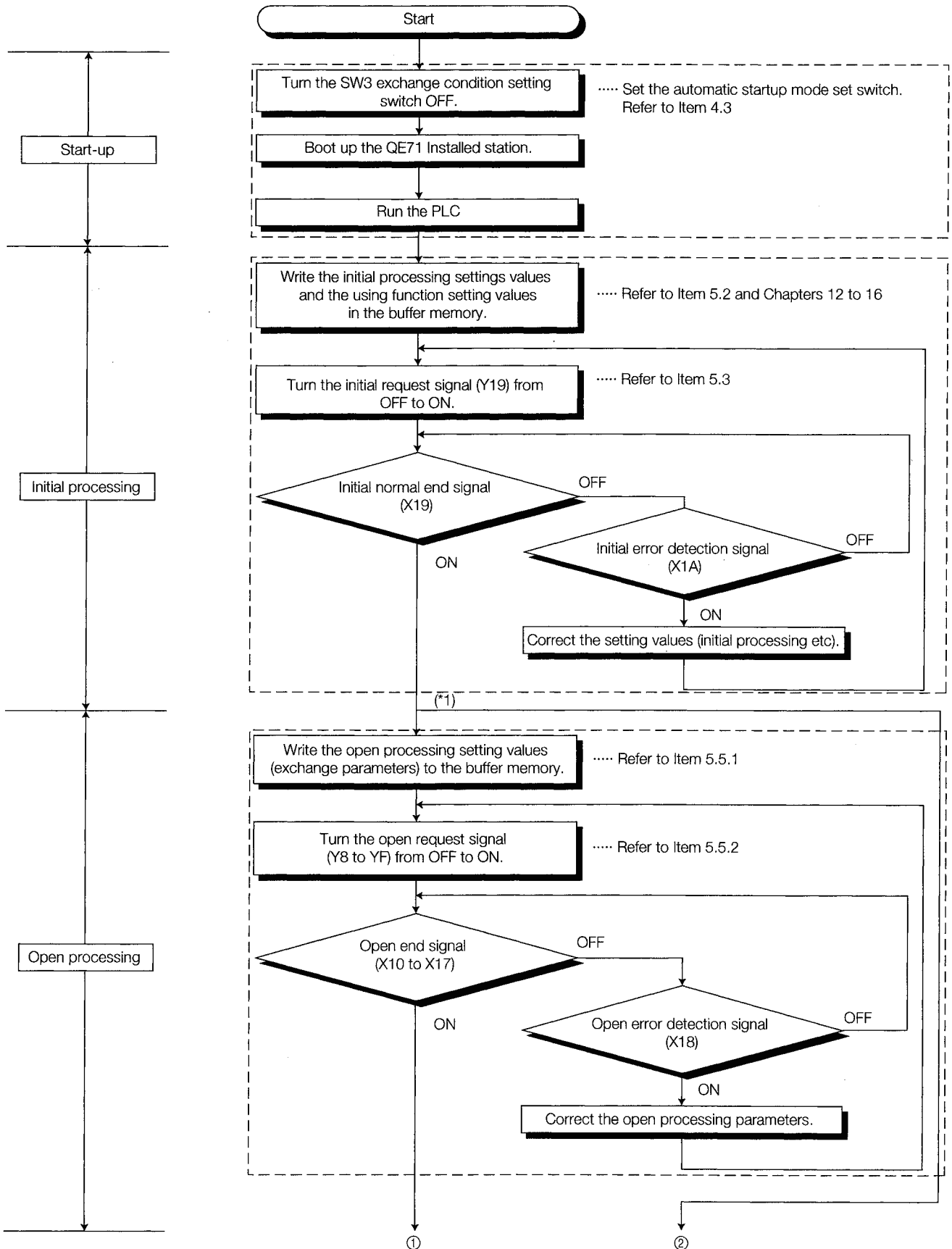

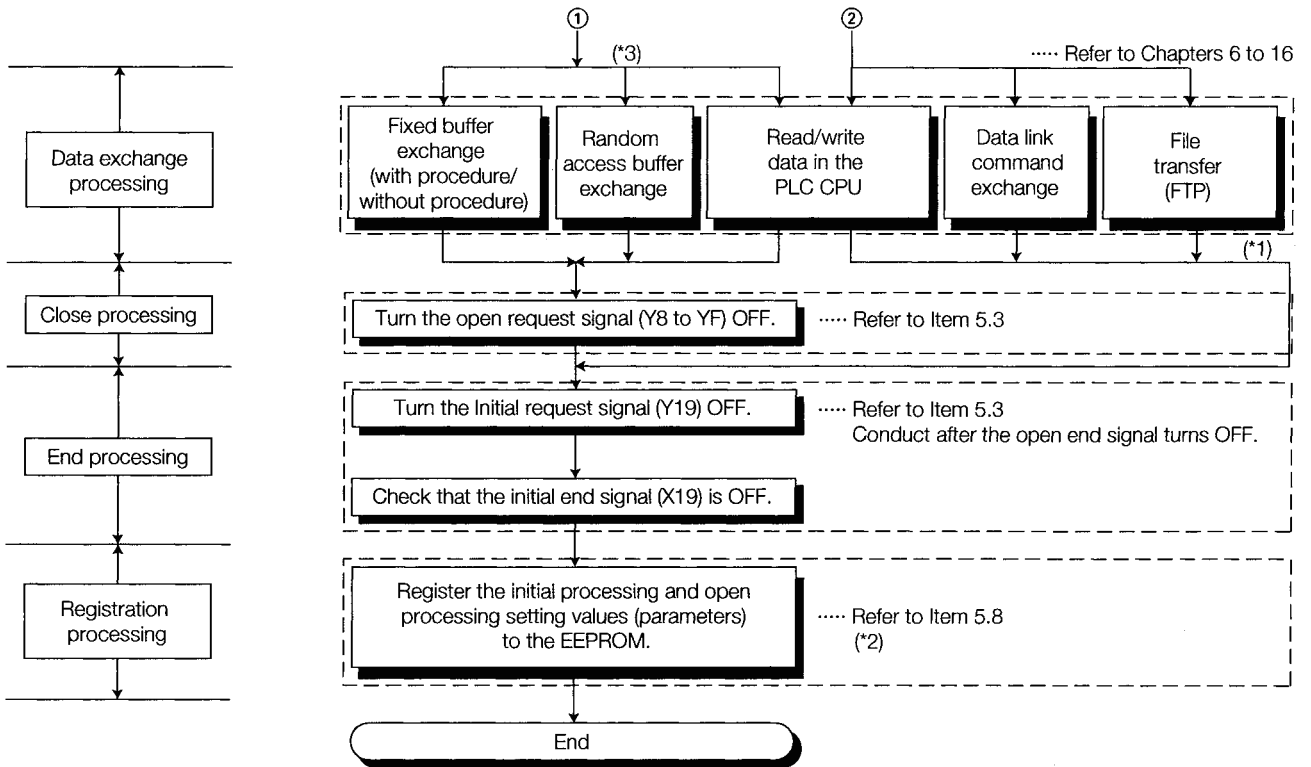

*1 Procedure when using an automatic open UDP port (Refer to Item 5.7).

*2 Use when necessary after confirming normal exchange. Exchange using the automatic startup mode shown [2] is possible.

*3 Once a communication line is connected, the following data communication can be performed between QE71 and other destination nodes using the port number specified by the communication parameter during the open processing.

① When "procedural fixed buffer communication" is specified during the open processing (When bit 9 of the usage setting communication parameter is off (procedural))

Functions that can be communicated using the applicable connection [Refer to Section 3.5.2 for data transmission procedures.]	1	Communication using fixed buffers (Refer to Chapter 6.) (a) Either transmission or reception is possible. * This is determined based on the setting for bit 0 of the usage setting communication parameter. <ul style="list-style-type: none"> • When bit 0 of the usage setting is off, transmission is enabled. • When bit 0 of the usage setting is on, reception is enabled. (b) Data transmission or reception between the PLC CPU and other nodes is performed using a fixed buffer (buffer memory) of the same number as the connection number of the open request signal sent when the communication line was opened. * The connection number of the open request signal is compatible with the fixed buffer number. (c) When transmitting and receiving data between the QE71 and other nodes, two communications lines are required.
	2	Communication using random access buffer (Refer to Chapter 8.) Data is read and written from/to the random access buffer of QE71.
	3	Read/write communication with respect to the data within the PLC CPU. (Refer to Chapters 9 and 10.) Data is read and written from/to the device memory of PLC CPU.

② When "non-procedural fixed buffer communication" is specified during the open processing (When bit 9 of usage setting communication parameter is on (non-procedural))

- Communication (transmission or reception) can be performed only by using the fixed buffer (Refer to Chapter 7).
- The number of fixed buffers used and the number of communication lines required for data transmission and reception are the same as those required for procedural fixed buffer communication.

2 Exchange procedures during automatic startup mode

(1) Communication procedure in the automatic start mode

This is the communication procedure used when the processing for entering set values (parameters) used for initial processing, open processing and special functions to the QE71 or the PLC CPU on the station where the QE71 is installed, has been completed using either of the following methods:

- The various set values (parameters) described above are entered to the QE71's EEPROM from a sequence program.
 - The various set values (parameters) described above are written to the PLC CPU of the station where the QE71 is installed as parameters by using the GPP.
- * In order to perform data-communication processing from (1) shown on the next page, it is necessary to have the portion of sequence program that performs data communication written to the PLC CPU in the station on which QE71 is installed beforehand.

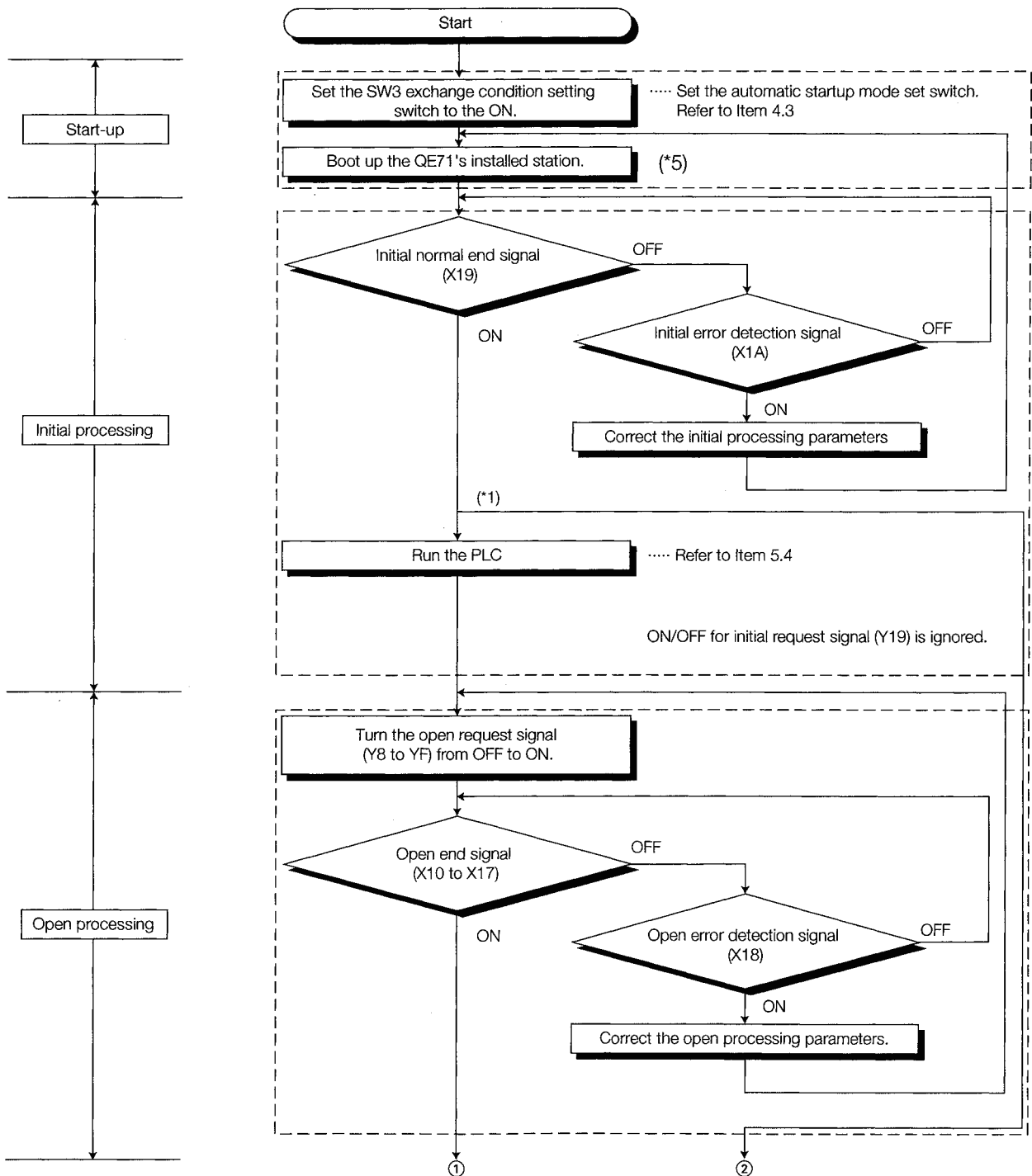

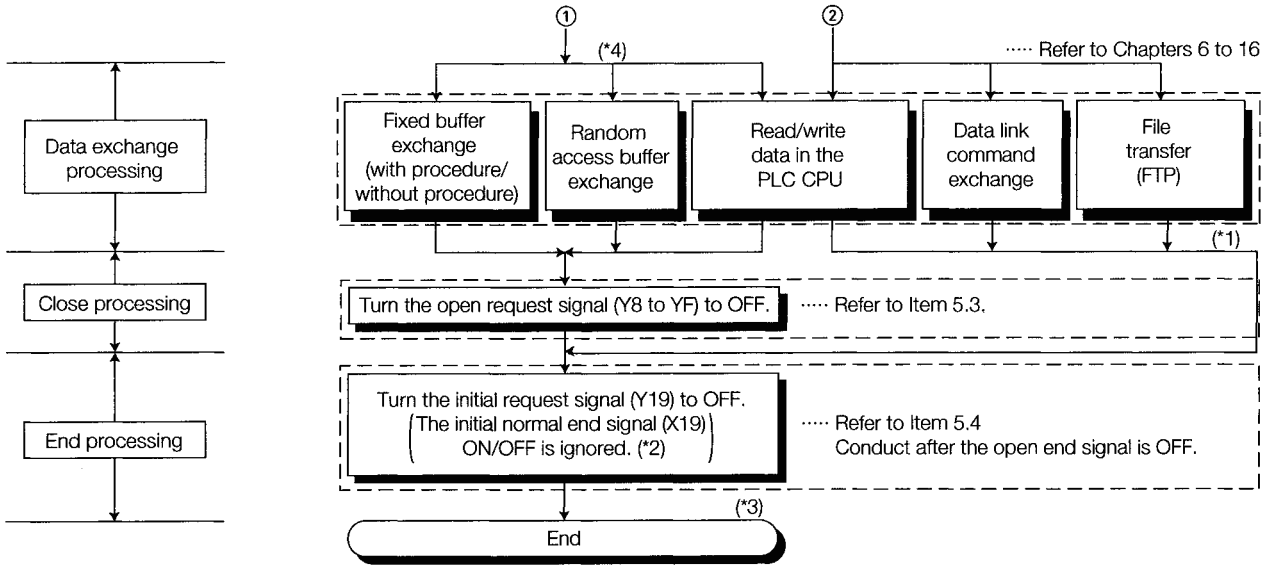

*1 Procedure when using automatic open UDP port (Refer to Item 5.7).

*2 See Item 5.4.1 Remark for the method to turn OFF the initial normal end signal (X19).

*3 When changing the request startup mode, set the SW3 exchange condition setting switch to OFF.

*4 Once a communication line is connected, either of the data communication can be performed between QE71 and other destination nodes using the port number specified by the communication parameter during the open processing.

(1) See *3.

*5 The QE71 will start up after reading the set values (parameters) that have been entered to the QE71's EEPROM and setting them to the buffer memory. (See Item 4.9.2)

Point

Perform the following operations to start the PLC CPU of the station on which a QE71 is mounted in order to access the PLC CPU via an Ethernet connection between GPPW and the QE71.

- ① Set the parameters for the QE71 using GPPW, and register them to the PLC CPU of the station on which the QE71 is mounted.
- ② Turn ON the exchange condition setting switch (SW3: automatic start up mode setting) of the QE71.

5.2 Connecting and Disconnecting Communication Lines

The arrangement between the nodes makes it necessary when beginning data exchange to connect a communication line between exchange partners, and when the data exchange is completed, to disconnect the communication line between exchange partners.

Following is an explanation of the connecting and disconnecting of QE71 communication lines and of the initial processing setting data for exchanging data between the QE71 and a remote node.

5.2.1 Connecting and Disconnecting Communication Lines Using Start Up Mode

1

Connecting communication lines for each start up mode (Initial processing, open processing)

When a communication line is connected by user processing, the communication line is automatically connected when the QE71 is booted up.

(a) Connecting a communication line using user processing

When the user specifies the parameters and sets the switches, one of the following two modes is used as the control method for initial processing and open processing, allowing the user to connect the communication line. Exchange can only be conducted with the remote mode for which the line was connected using this initial processing and open processing.

① Request start up mode

This is the mode where the setting values required for initial processing and open processing are written to the buffer memory and all of the process requests are performed from the PLC CPU.

② Automatic start mode

This mode uses the setting values already registered in the QE71's EEPROM by the user to automatically conduct initial processing. Open processing is conducted by the PLC CPU.

No matter which mode is used to connect the communication lines, a specified port No. can be used to exchange from a remote mode using the fixed buffer, random access buffer, or to read and write data to the PLC CPU.

(b) Automatically connecting the communication line when the QE71 is booted up

The port that is used when the communication line is connected is called the automatic open UDP port. The port is automatically opened at the start of QE71 and the communication line is connected. (The port number for read/write of data in the PLC CPU is the default value "5000".)

From remote nodes, read/write of data in the PLC CPU and file transfer can be conducted. For details regarding data communication using an automatic open UDP port, refer to the explanation in Item 5.7.

2

Communication line disconnect (Close processing, end processing)

When data exchange with a remote node has been completed after a communication line was connected using one of the modes described in **1** above, the communication line is disconnected using the user software processing described below.

(a) Disconnection of the communication line connected by user processing

Close processing and end processing are conducted by the PLC CPU.

(b) Disconnection of communication lines connected automatically when the QE71 booted up

End processing is conducted by the PLC CPU.

If the condition described in Item 3.5.3 occurs, the line will be forcefully closed.

5.2.2 Data for Initial Processing

This section explains the parameter setting area for conducting initial processing. The network manager (the person who plans the network and manages the IP addresses) writes the values to be used in this area before initial processing is conducted. (Refer to Point at the end of Item 4.8 5 about whether the parameter should be set.)

Buffer Memory

(Address)	Initial processing parameter setting area	(32 Words)	Default values
0 to 1H (0 to 1)	Local station QE71's IP address	(2 Words)	C00001FEH
2 to 3H (2 to 3)	System area	(2 Words)	—
4H (4)	Special function setting	(1 Word)	100H (256)
5 to AH (5 to 10)	System area	(6 Words)	—
BH (11)	TCP ULP time out value	(1 Word)	3CH (60)*1
CH (12)	TCP zero window timer value	(1 Word)	14H (20)*1
DH (13)	TCP retransmission timer value	(1 Word)	14H (20)*1
EH (14)	TCP end timer value	(1 Word)	28H (40)*1
FH (15)	IP setup timer value	(1 Word)	0AH (10)*1
10H (16)	Response monitoring timer value	(1 Word)	3CH (60)*1
11H (17)	Destination existence check start interval timer value	(1 Word)	4B0H (1200)*1
12H (18)	Destination existence check interval timer value	(1 Word)	14H (20)*1
13H (19)	Number of retransmit tries for destination existence check	(1 Word)	3H (3)
14H (20)	Automatic open UDP port No.	(1 Word)	1388H(5000)
15 to 1DH (21 to 29)	System area	(9 Words)	—
1EH (30)	TCP Maximum Segment transmission setting (*2)	(1 Word)	8000H
1FH (31)	System area	(1 Word)	—

*1 The setting value units used is 500ms. (Timer value = setting value × 500ms).

*2 Applicable to the products of the following software versions.

AJ71QE71N3-T, A1SJ71QE71N3-T : "Version A" and later

Other QE71 : "Version E" and later

The TCP Maximum Segment transmission function is not applicable to the products earlier than the above. This area is used as a system area.

1 Local station QE71's IP address (Default value = C00001FEH) Address 0H to 1H (0 to 1)

- (a) The local station QE71's IP address is set following the standard IP address (Refer to Item 11.3).
 - ① Set it so that the local station QE71 and the partner remote node to which exchange is being conducted are set to the same class network address. In the following example, the QE71 and the partner remote node ① ② IP address class network address is set at "C00001□□H." (The host address can be freely set to any No. other than "00H" and "FFH.")
 - ② When the IP address network address of the local station QE71 and the partner remote node to which exchange is being conducted are not the same, a setting for using the router relay function is required (Refer to Chapter 12). In the following example, the setting values (parameters) used for the router relay function when exchange is conducted between the QE71 and the remote node ③ are set in the local station QE71.

(Example) When the local station QE71's IP address is class 3 (upper level: displayed in hexadecimal numbers, lower stage : displayed in decimal numbers).

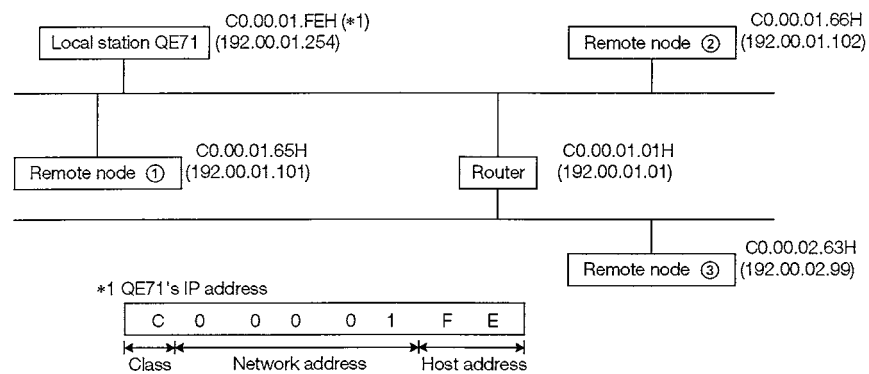

- (b) Except when a router relay function (Refer to Chapter 12) or there is mixed use with another system, the IP addresses can be freely allocated as described in (a) above.

Remarks

When the router relay function is used and there is mixed use with another system, please use addresses that conform with the standard IP addresses used on the global scale.

* Standard IP Address

IP addresses are divided into classes to allow an address system that corresponds to the size of the network to be selected. (Refer to Item 11.3)

- (c) The local station QE71 IP address can also be set at the GPP (Product after the software version shown in Item 2.2 **4**) Common Parameter (Ethernet setting) screen. (See Item 4.8)

2 Special function setting (Default value = 100H (256)) Address 4H (4)

(a) Set the special functions of QE71 including the router relay function as follows:

(Bit location)	b15	to	b10	b9	b8	b7	b6	b5	b4	b3	b2	b1	b0
	0			③	②	①	0						

- ③ FTP function setting (b9, b8)
00: not for use
01: for use (default value)
- ② MELSECNET/10 relay
Setting for the conversion method for exchange (b7, b6)
00: Automatic response method (default value)
01: IP address calculation method
10: Table conversion method
11: Combined method
- ① Router relay function setting (b5, b4)
00: not for use (default value)
01: for use

(b) By setting a value, the value set for the corresponding function becomes valid.

- ① When the router relay function is specified
When “for use” is set, the value set for the subnet mask setting area and router relay parameter setting area in the buffer memory (addresses 512 to 549) becomes valid.
- ② When the conversion method is specified
When the “table conversion method” or the “combined method” is specified, the value set for the Station No. <-> IP information setting area in the buffer memory (addresses 552 to 938) becomes valid.
- ③ When the FTP function is specified
When “for use” is set, the value set for the FTP parameter setting area in the buffer memory (addresses 944 to 959) becomes valid.

(c) The special function settings can also be set at the GPP (Product after the software version shown in Item 2.2 **4**) set the parameter setting screen corresponding to that function. (See Item 4.8)
To use a special function, set up data in the buffer memory during initial processing, according to the reference section of the applicable function.

3 TCP ULP time out value (Default value = 3CH(60), setting time = setting value × 500ms) Address BH (11)

- (a) Sets the pocket existence time during TCP data transmission.
This timer value is passed as a parameter when a TCP connection is opened or data are transmitted.
- (b) Specifies the setting value as from 1H to 7FFFH. (*1) (*3)

4 TCP zero window timer value (Default value = 14H(20), setting time = setting value × 500ms) Address CH(12)

- (a) The window shows the reception buffer on the reception receiving end.
- (b) When there is no more space in the reception buffer on the receiving end (window size = 0), the transmitting end waits to transmit data until there is space in the reception buffer on the receiving end. At this time, the receiving end follows the TCP zero window timer value to transmission window check packet to the reception end to check the receiving possibility condition.
- (c) The setting value is specified to between 1H and 7FFFH. (*3)

- 5** **TCP retransmission timer value (Default value = 14H(20), setting time = setting value × 500ms) Address DH(13)**
- (a) If ACK is not returned during TCP open and data transmission, the retransmission time will be set. This timer is also used for the existence time of the ARP function. (An ARP is retransmitted after the time of 1/2 TCP retransmission timer value when no response is returned to the transmitted ARP request.)
Or this timer sets minimum setting time of delivery monitoring time for the data link command.
- (b) The setting value is specified between 1H and 7FFFH. (*1) (*3)
- 6** **TCP end timer value (Default value = 28H(40), setting time = setting value × 500ms) Address EH(14)**
- (a) Sets the monitoring time when waiting for FIN to be received from the partner node after the local station has transmitted FIN and ACK has been received from the partner node when the local station closes the TCP connection.
- (b) When FIN is not received from the partner node after the TCP end timer time, RST is transmitted to the partner node to forcefully close the line.
- (c) The setting value is specified to between 1H and 7FFFH. (*3)
- 7** **IP setup timer value (Default value = 0AH(10), setting time = setting value × 500ms) Address FH(15)**
- (a) Exchange data is sometimes divided and transmitted by IP level due to the transmitting station's or the receiving station's buffer limitations. This sets the time to wait until the following divided data is restored (reassembled) when the QE71 receives the divided data.
- (b) The setting value is specified to between 1H and 7FFFH. (*3)
- 8** **Response monitoring timer value (Default value = 3CH(60), setting time = setting value × 500ms) Address 10H(16)**
- (a) Sets to the following time.
- ① The wait time from when a command is transmitted until a response is received.
 - ② When a divided message is transmitted, the time from the first message transmission until the final message is received.
- (b) The setting value is specified to between 1H and 7FFFH. (*3)
- 9** **Destination existence check start interval timer value (Default value = 4B0H(1200), setting time = setting value × 500ms) Address 11H(17)**
- (a) When the exchange with the partner remote node by the connection opened by destination existence check is finished until existence check is begun.
- (b) The setting value is specified as between 1H and 7FFFH. (10 minutes when the default value is 4B0H(1200)) (*2)
- 10** **Destination existence check interval timer value (Default value = 14H(20), setting time = setting value × 500ms) Address 12H(18)**
- (a) Sets the interval time for conducting retry and existence check when no response is received from the partner remote node that is conducting the existence check for the connection opened by the destination existence check.
- (b) The setting value is specified between 1H and 7FFFH.
- 11** **Number of retransmit tries for destination existence check (Default value = 3H(3)) Address 13H(19)**
- (a) Sets the number of retries and existence checks when a response is not received from the partner remote node that is conducting the existence check for the connection that was opened by the destination existence check.
- (b) The setting value is specified between 1H and 7FFFH.

12 Automatic open UDP port No. (Default value = 1388H(5000))..... Address 14H(20)

- (a) At the startup of QE71, set the number of QE71's UDP/IP port that automatically opens for read/write of data in the PLC CPU from remote nodes. (This port is called "the automatic open UDP port.")
- (b) By using the automatic open UDP port, exchange without a sequence program at the request of remote node is enabled.
For details regarding using an automatic open UDP port for data exchange, refer to the explanation in Item 5.7.
- (c) The setting value is specified as between 400H and 1388H (1024 to 5000) or 138BH to FFFEH (5003 to 65534). (Port No. 5001 and 5002 is used by the QE71 system. It cannot be specified by the user.)

13 TCP Maximum Segment transmission setting (Default value = 8000H)..... Address 1EH(30)

- (a) Set whether TCP Maximum Segment Size Option transmission is enabled or not.
- (b) Specify the setting with either of the following values.
0H: Enable TCP Maximum Segment Size Option transmission
8000H: Enable TCP Maximum Segment Size Option transmission
- (c) The setting is made valid after completion of the initial processing.
- (d) MELSOFT series products supporting the TCP Maximum Segment transmission function
For setting the "Enable TCP Maximum Segment Size Option transmission", use the following MELSOFT products.
GX Developer : Version8.07H or later
MX Component : Version3.03D or later
MX Links : Version3.08J or later
- (e) MELSOFT series products not listed above (d)
When using a MELSOFT product that is not listed above (d) to make communication via Ethernet, set it to "Disable TCP Maximum Segment Size Option transmission" or use UDP/IP type communication.
Otherwise, the sequence program may not function correctly (read/write is incorrect).

- *1 When exchange errors occur due to noise, change the setting value to a higher number of retries.
 The retry number is determined using the following formula. (For the default value 2 = $(60 \div 20) - 1$)

$$\text{Number of retries} = ((\text{TCP ULP time out value}) \div (\text{TCP retry timer value})) - 1$$

(Example) When data cannot be transmitted when the setting value makes the number of retries 2, the transmission error detection signal will turn on with the timing shown in the diagram below. (When fixed buffer No.3 is used)

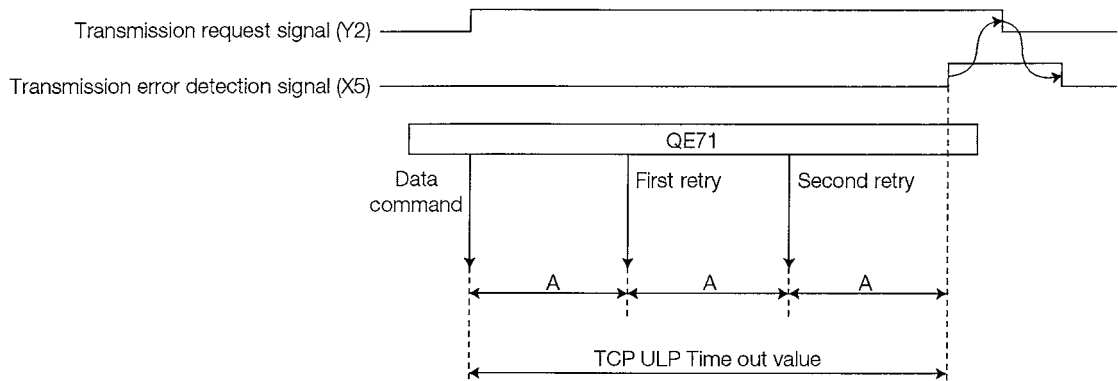

A : TCP retransmission timer value
 (The data retransmission time when ACK is not returned after the data is transmitted)

Remarks

When removing the retry processing shown above (0 times), perform the following setting:
 TCP ULP time out value = TCP end timer value = TCP retransmission timer value
 (Each timer value should be the same.)

- *2 The destination existence check is the function that the QE71 uses to check whether the partner remote node is operating correctly when exchange with the partner remote node that is opened by the connection has not been conducted for a set period of time. In particular, when exchange has not been conducted for a set period of time with the remote node, it transmits a PING command (ICMP echo request/response function) to the partner node to conduct an existence check of whether a response can be received.

The QE71 conducts existence checks in accordance with the destination existence check settings (Refer to Item 5.5.1 [1] (b) ②) for the setting values given in [9] to [11] in this section and during opening processing.

(Example) When the setting value is for the number of retries to be 3, the QE71 conducts existence checking with the timing shown in the figure below. When errors are detected, the open error detection signal turns on and stores the error code (CO35H) to the open error code storage area.

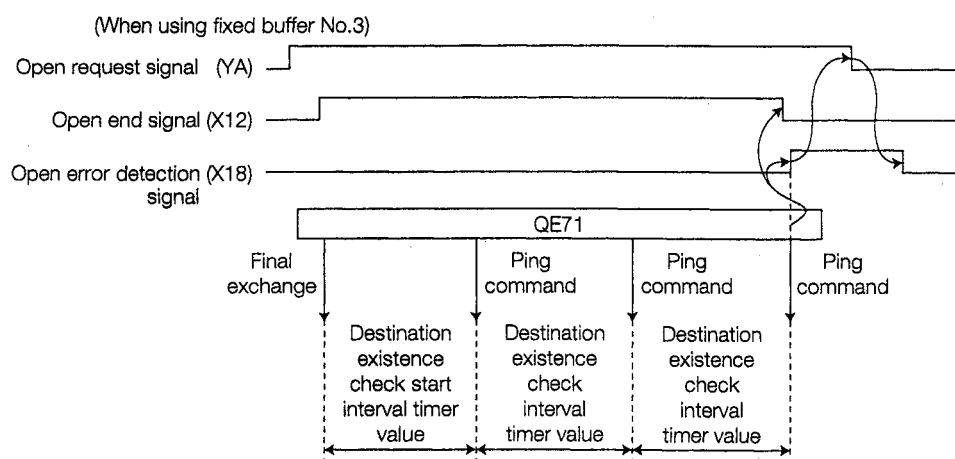

In addition, if the initial processing has normally been completed, the QE71 automatically sends a response for a PING command echo request command received from a remote node.

(The QE71 sends a response for a PING command received even when the connection to be used for data exchange with a remote node is closed.)

- * If an error is detected in the external device side with this check, the applicable connection will be closed (the line will be disconnected). Open the connection using a user program.
- *3 The setting value of each timer is as follows.

- (a) Designate the setting value of each timer on the QE71 side in such a way that the following relations are met.

$$\bullet \left[\text{Response monitoring timer value} \right] \geq \left[\text{TCP ULP timeout value} \right] \geq \left[\text{TCP end timer value} \right] \geq \left[\text{TCP retransmission timer value} \right] > \left[\text{IP assembly timer value} \right]$$

$$\bullet \left[\text{TCP retransmission timer value} \right] = \left[\text{TCP zero window timer value} \right]$$

Furthermore, when connecting a line using our products (QE71, E71, E71S3), you should make sure that both nodes have the same settings.

- (b) Designate the setting value of each timer on the remote node side in such a way that the following relations are met.

Communication errors such as transmission timeouts may occur more frequently if the timer values are not set so that they satisfy the following relationships.

- $\left[\begin{array}{l} \text{TCP retransmission timer value} \\ \text{on the remote node side} \end{array} \right] > \left[\begin{array}{l} \text{TCP retransmission timer value} \\ \text{on the QE71 side} \end{array} \right]$
- $\left[\begin{array}{l} \text{Monitoring timer value in application} \\ \text{software on the remote node side} \end{array} \right] > \left\{ \left[\begin{array}{l} \text{TCP ULP timeout value} \\ \text{on the QE71 side} \end{array} \right] \times n + 1 \right\}$
 *1 n is the number of TCP segment transmissions and can be obtained via the following calculation:

$$n = \left\lceil \frac{\text{Size of the message transmitted by QE71}}{\text{Maximum Segment size}} \right\rceil$$
 fractions below decimal point are rounded up

(Example 1) Number of TCP segment transmissions when communicating via the same line

The Maximum Segment size is 1460 bytes via the same line (without going through a router) and the number of TCP segment transmissions is as follows:

n = 1, if the size of the message transmitted by QE71 is 1460 bytes or less.

n = 2, if the size of the message transmitted by QE71 is greater than 1460 bytes.

(Example 2) Number of TCP segment transmissions when communicating via separate lines

The Maximum Segment size is at least 536 bytes on a separate line (via dialup router, etc.) and the number of TCP segment transmissions is as follows:

n = 1, if the size of the message transmitted by QE71 is 536 bytes or less.

n = 2, if the size of the message transmitted by QE71 is greater than 536 bytes and no more than 1072 bytes.

n = 3, if the size of the message transmitted by QE71 is greater than 1072 bytes and no more than 1608 bytes.

Remarks

In the above relationship, the number of retries for transmission from QE71 can be increased or decreased by changing the TCP retransmission timer value (refer to *1).

By performing the following setting, number of retries becomes 0.

- $\left[\begin{array}{l} \text{TCP ULP} \\ \text{timeout value} \end{array} \right] = \left[\begin{array}{l} \text{TCP end timer} \\ \text{value} \end{array} \right] = \left[\begin{array}{l} \text{TCP retransmission} \\ \text{timer value} \end{array} \right]$

Point

- (1) The initial processing parameter setting area setting values are registered in the QE71's EEPROM. The setting values registered in the EEPROM are used as the default values when the QE71 is started up.
- (2) It is recommended that the default values are used for each timer value. Before changing them, consult with the managers of the partner equipment and systems, then increase/decrease each set value according to the equation described in *3.
- (3) Refer to Item 4.8 [5](#) for information regarding the parameters necessary for settings during QE71 initialization processing when the QE71 functions are used.

5.3 Initial Processing and End Processing During Request Start Up Mode

This section explains about the QE71 initial processing and end processing conducted by the PLC CPU when a communication line is connected and data is exchanged with the remote node in the request start up mode.

Lines connected using request start up mode conduct mobile on line operations.

5.3.1 Initial Processing and End Processing Procedures

This section explains about the QE71's initial processing and end processing procedures.

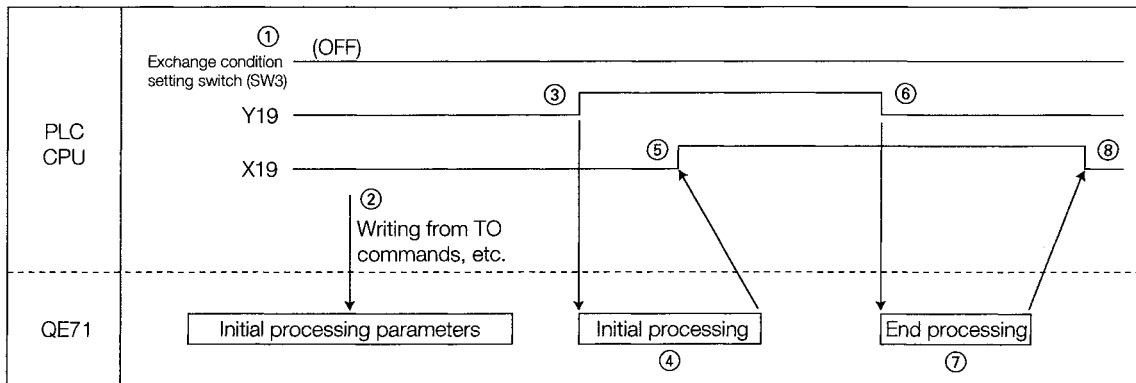

Initial processing

- ① Turn OFF the exchange condition setting switch (SW3: automatic start up mode setting), start the station on which the QE71 is mounted (for instance by turning the power supply on), and place the PLC CPU in the RUN state.
- ② The initial processing parameters are written in the buffer memory.
 - * When writing the initial processing parameters, write set value for each exchange parameter and special function to be used.
- ③ The sequence program turns the initial request signal (Y19) on.
- ④ The QE71 executes initial processing.
- ⑤ The initial normal end signal (X19) turns on when the initial processing ends normally. (A PING command can be sent from the remote node to the PLC CPU.) If it ends with an error, the initial error detection signal (X1A) will turn on.

End processing

- ⑥ The sequence program turns the initial request signal (Y19) off after the next signal off is checked. (*1)
 - Transmission request signal/reception end check signal (Y0 to Y7)
 - Transmission normal end signal/reception end signal (X0, X2...)
 - Transmission error detection signal (X1, X3...)
 - Open request signal (Y8 to YF), Open end signal (X10 to X17)
 - Open error detection signal (X18)
- ⑦ The QE71 executes the end processing.
- ⑧ The initial normal end signal (X19) turns off when the end processing is normal end. When it is error end, the initial error detection signal (X1A) turns on.

*1 If end processing is requested while the communication line is being connected (the connection is open), close processing will be performed for the open communication line and end processing will then be performed, if data transmission/reception with a remote node is not being performed.

If data transmission/reception with a remote node is being performed, close processing will be performed forcibly (close processing will be performed after an ABORT (RST) instruction is sent in the case of TCP/IP communication) for the open communication line. Also, the transmission error detection signal (X1, ...) will turn on.

5.3.2 Example Program

This section explains the sequence program example for conducting QE71 initial processing and end processing.

(Example) The following is an example program.

- (1) The QE71 is installed in the main base's "0" slot.
- (2) The initial processing parameters are shown below.
 - (a) The QE71's IP address is "A20009C0H(162.0.9.192)."
 - (b) Values other than the IP address are used as default values.

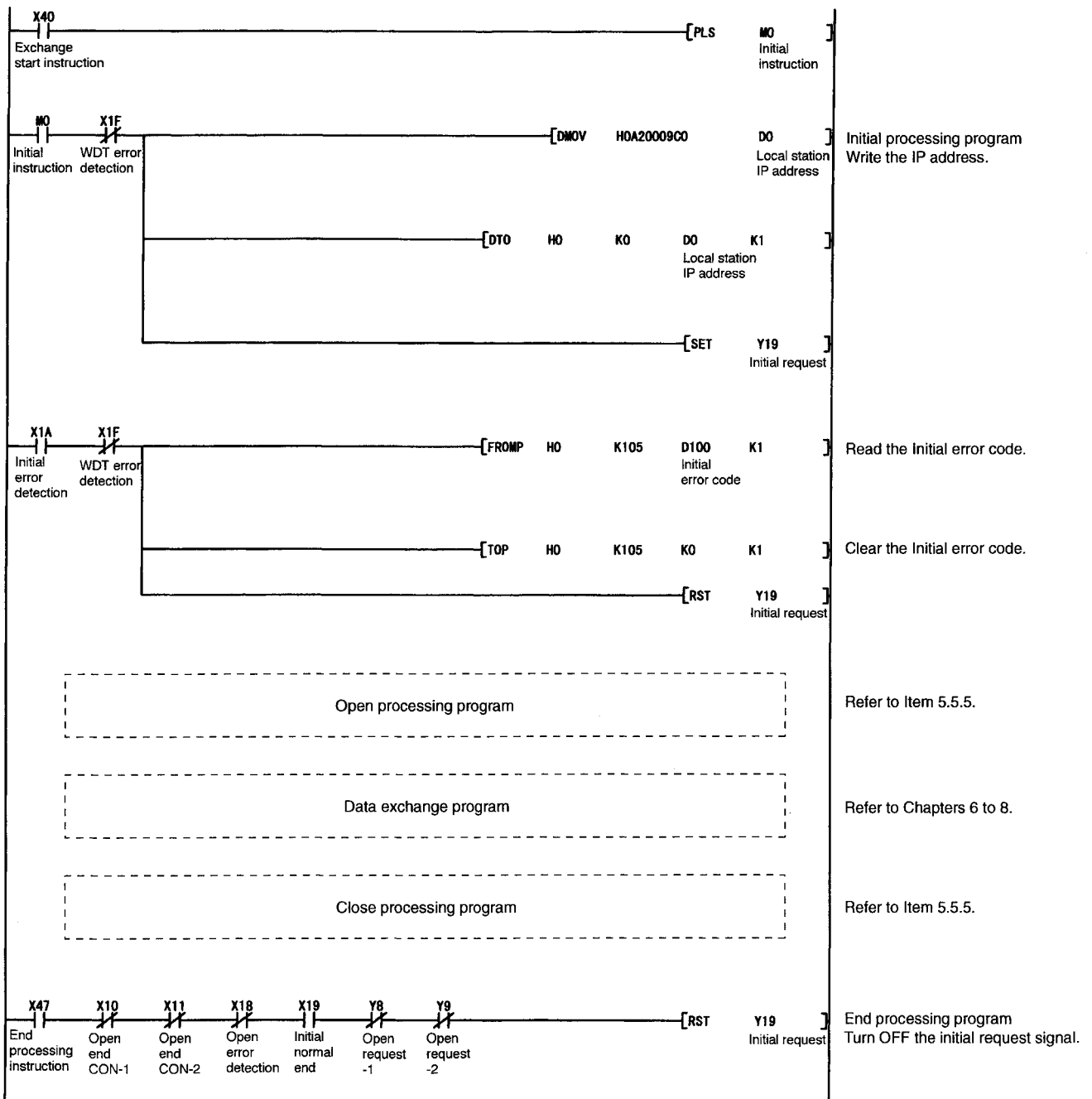

5.3.3 Confirming the Completion of Initial Processing

When the initial processing of the QE71 is completed normally, the [RDY] LED indicator on the QE71 flashes.

Using any of the methods described below, it is possible to check the line connection status between remote nodes and the QE71 as well as the completion status of the QE71's initial processing.

Point

The status of the QE71 becomes data exchange enabled when the initial processing completes normally. Perform data exchange by referring to the reference sections of various data exchange functions.

If the initial does not complete normally, check the contents of the error and take corrective actions as described below, then execute the initial processing again.

- Check the error code using the "Parameter status" of the Ethernet diagnostics with GPPW. (See Item 17.4.1.)
- Check the contents of the error indicated by the error code, then take corrective actions. (See Item 17.1.3.)

(Checking with GPPW) ... See [1]

Perform a PING test of the Ethernet diagnostic function, and check with GPPW whether the initial processing of the QE71 on the same Ethernet line completes (test via the Ethernet board).

(Checking with the PING command (from IBM/AT compatible PC to QE71) ... See [2]

Send a PING command from the PC, and check whether the initial processing of the QE71 completes.

(Checking with the loop back test via read/write exchange of data in the PLC CPU)

... See Items 4.10 and 10.9.2

Send a QE71 command for loop back test from the PC, and check whether the initial processing of the QE71 completes.

Remark

The following lists the devices that can check whether the initial processing of the QE71 completes.

Device to be checked		Check method		QE71	Q Series Ethernet module (function version)		A Series E71S3	Range of access
					A	B		
Ethernet diagnostic function of GPPW	Via the Ethernet board	PING test	○	○	○	○	Local stations Ethernet network only	
		Loop back test	×	○	×	×		
Via the Ethernet board	Via the CPU	PING test	×	○	×	×	One layer of the Ethernet network only	
Sending commands from the PC	PING command		○	○	○	○	Local stations Ethernet network only	
	Read/write exchange of data in the PLC CPU (loop back test)		○	○	○	○		

○: Possible ×: Not possible

1

PING test using GPPW (via the Ethernet board)

The following explains how to check the completion status of the QE71's initial processing using the PING test function of Ethernet diagnostics.

(a) PING test (via Ethernet board)

- ① The PING test is performed with GPPW on the QE71 (*1) for which initial processing has been completed on the same Ethernet line or the external device (such as a PC) having the designated IP address.

* The PING test can also be performed on the Q/A Series Ethernet modules.

- ② The following items can be checked by performing the PING test.
 - Whether line connection with the test target device is properly established
 - When the target device is a PLC, whether the parameters for initial processing are set correctly, and whether the initial processing is completed normally
- ③ The PING test can be performed for the modules on the same Ethernet as that of the local station (same subnet address).

(b) Executing the PING test

The example below explains the PING test methodology and GPPW settings when a PING test is performed with GPPW for the modules on the same Ethernet.

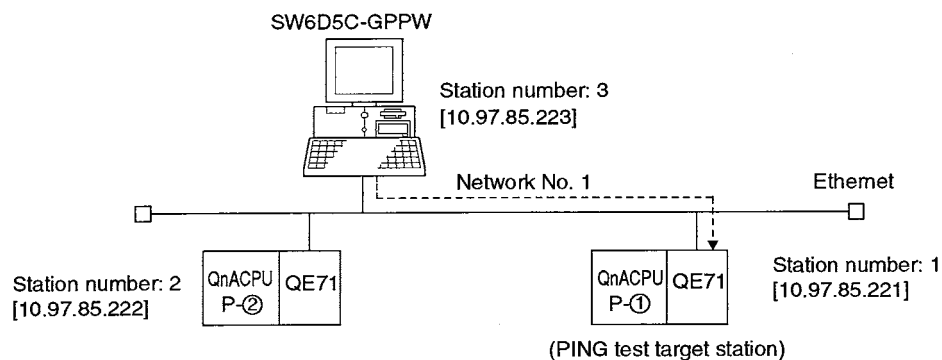

① Settings on the PING test target station side

- Set the following QE71 parameters for each PING test target station using GPPW. Use default values for setting items other than those listed below.

Setting screen	Setting item	Description of setting	
		QnACPU P-①	QnACPU P-②
Network parameters setting the number of MNET/10H Ethernet cards	Network type	Ethernet	Ethernet
	Starting I/O number	0000	0000
	Network number	1	1
	Group number	1	1
	Station number	1	2
Operational setting	IP address	[10. 97. 85. 221]	[10. 97. 85. 222]

- Load the parameters to the PLC CPU of the applicable station.
- Restart the PLC CPU and perform the initial processing of the QE71.
(When the initial processing completes normally, the [RDY] LED indicator of the QE71 flashes.)

② Designating the GPPW connection destination (connecting to QnACPU P-② in the figure below)

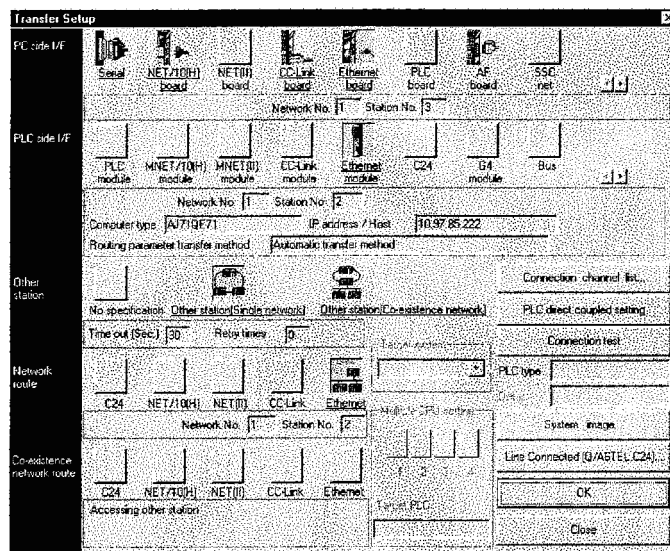

③ Executing the PING test using GPPW

- Select the PING test on the Ethernet diagnostics screen.
GPPW → [Diagnostics] → [Ethernet diagnostics] → PING test
- Perform the settings indicated below, then click the Execute button. The execution results of the PING test are displayed.

(Example) The following shows the flow of the PING test when "4" is designated as the transmission count.

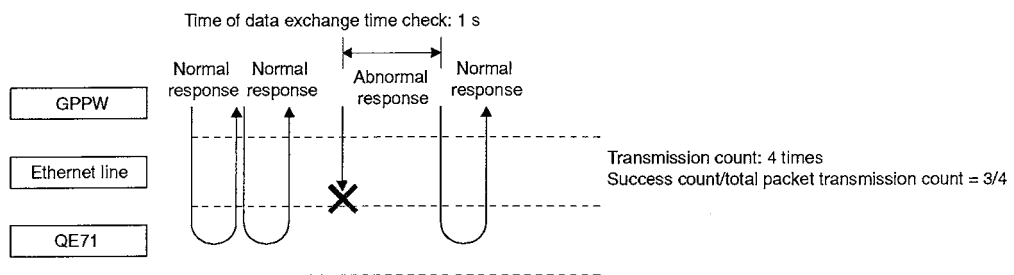

Normal response occurs when the response for the PING test is received within the time of data exchange time check.

[PING test screen (via the Ethernet board)]

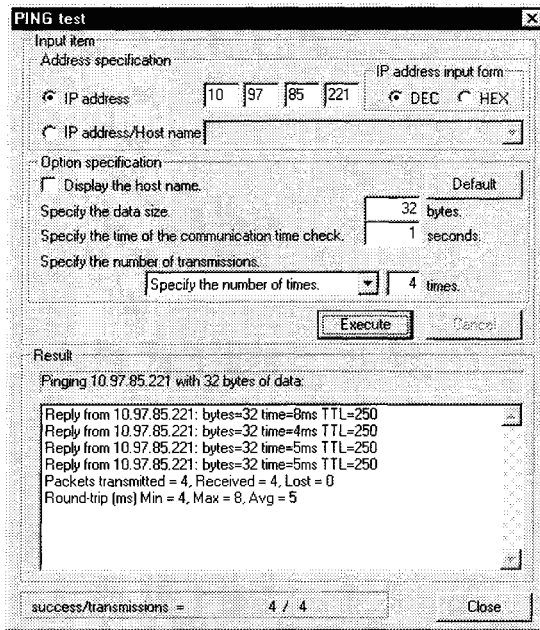

(Example of normal completion)

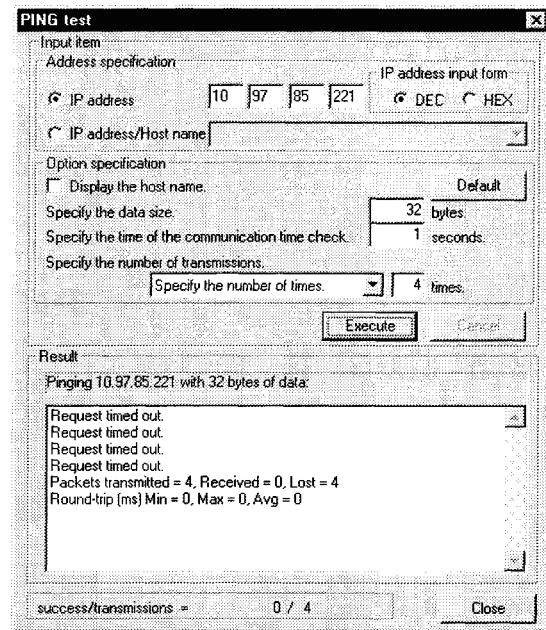

(Example of abnormal completion)

[Display contents]

Item name	Description of item setting	Setting range/option
Address specification	IP address	Specify the IP address of the PING test target station. (IP address of the target station)
	IP address input format	Select the input format of the IP address. Decimal/hexadecimal
	Host name	Specify the host name of the PING test target station. —
Option specification	Display the host name	Results are displayed using the host name corresponding to the IP address in the result display field. —
	Specify the data size	Specify the size of the system data to be transmitted during the PING test. 1 to 8192 bytes (Specify 1460 bytes or less for the QE71.)
	Specify the exchange time check	Specify the completion wait time for the PING test. 1 to 30 seconds
	Specify the transmission count	Specify the transmission count. • Specify the count. • Execute until interrupted.
Result	Display the result of the PING test. —	
Success count/total packet transmission count	Display the total packet transmission count and its success count during the PING test execution. —	

(Address specification)

The PING test target station (external device subject to the PING test) is specified by the IP address or the host name.

- ① Specification using the IP address
 - Select the input format for the IP address (select: Decimal or hexadecimal)
 - Specify the IP address of the external device according to the input format (decimal or hexadecimal).
- ② Specification using the host name
 - Specify the host name of the external device set in the DNS server or the HOSTS file for the PC on which GPPW is installed.
 - * The IP address can also be entered in the host name specification field.

(Option specification)

Set the details for the PING test. (No setting required if the default settings are used.)

- ① Display the host name.
Select the host name in the result display field instead of the IP address for the PING test destination device.
- ② Specify the data size.
Specify the size of the system data to be transmitted for the test during the PING test.
Input range: 1 to 8192 bytes (default: 32 bytes)
* The QE71 will return a response of 1460 bytes if the PING test is performed by specifying a data size of 1460 bytes or more.
- ③ Specify the time of the data exchange time check.
Specify the response wait time for the PING test.
Input range: 1 to 30 s (default: 1 s)
- ④ Specify the transmission count.
Specify the number of times the PING test is to be executed.

Selection item	Description of item	Remark
Specify the count	The PING test is executed for the number of times specified.	Transmission count: 1 to 50 times (default: 4 times)
Execute until interrupted	Execute until interrupted	—

(Result)

The results of the PING test are displayed.

<When the test is completed abnormally>

Upon checking the following, perform the PING test again.

- Whether the QE71 is mounted on the base unit properly
- The connection status to the Ethernet.
- The contents of the parameters loaded to the PLC CPU.
- The operating status of the PLC CPU (whether any errors have occurred)
- The IP addresses set in the PC installed with GPPW and the PING test target station
- Whether the external devices were reset when the QE71 was replaced

(Success count/total packet transmission count)

The success count and the total packet transmission count when the PING test is executed are displayed.

2

Sending the PING command from the PC

The following example shows how to send a PING command from a remote node (IBM/AT compatible PC) connected on the same Ethernet to the local station's QE71 and check the normal completion of the QE71's initial processing. (An example of check between devices having the same class and subnet address ID in the IP addresses)

[Specification method]

ping IP address

[Program example]

IP address for the QE71: 192. 0. 1. 254

Example of screen at normal completion

```
C:\>ping 192.0.1.254 ... Executes the PING command

Pinging 192.0.1.254 with 32 bytes of data:

Reply from 192.0.1.254: bytes=32 time=1ms TTL=128
Reply from 192.0.1.254: bytes=32 time<10ms TTL=128
Reply from 192.0.1.254: bytes=32 time<10ms TTL=128
Reply from 192.0.1.254: bytes=32 time<10ms TTL=128

Ping statistics for 192.0.1.254:
    Packets: Sent = 4, Received = 4, Lost = 0 (0% loss)
    Approximate round trip times in milli-seconds:
        Minimum = 0ms, Maximum = 1ms, Average = 0ms

C:\>_
```

Example of screen at abnormal completion

```
C:\>ping 192.0.1.254 ... Executes the PING command

Pinging 192.0.1.254 with 32 bytes of data:

Request timed out:
Request timed out:
Request timed out:
Request timed out:

Ping statistics for 192.0.1.254:
    Packets: Sent = 4, Received = 0, Lost = 4(100% loss)
    Approximate round trip times in milli-seconds:
        Minimum = 0ms, Maximum = 0ms, Average = 0ms

C:\>_
```

<When the test is completed abnormally>

Upon checking the following, send the PING command again.

- Whether the QE71 is mounted on the base unit properly
- The connection status to the Ethernet.
- The contents of the parameters loaded to the PLC CPU.
- The operating status of the PLC CPU (whether any errors have occurred).
- The IP addresses of the transmission destination QE71 specified by the PING command.

5.4 Initial Processing and End Processing During Automatic Start Up Mode

This section explains about the QE71's initial processing and end processing performed by the PLC CPU when exchanging data with a remote mode connected by a communication line using the automatic start up mode.

The automatic start up mode connects the line after checking that data can be exchanged normally with the partner remote node.

When conducting fixed buffer exchange, random access buffer exchange, and reading and writing data to the PLC CPU, exchange can be conducted after open processing (Y8 through YF are turned on).

5.4.1 Initial Processing and End Processing Procedures

This section explains the QE71's initial processing and end procedures.

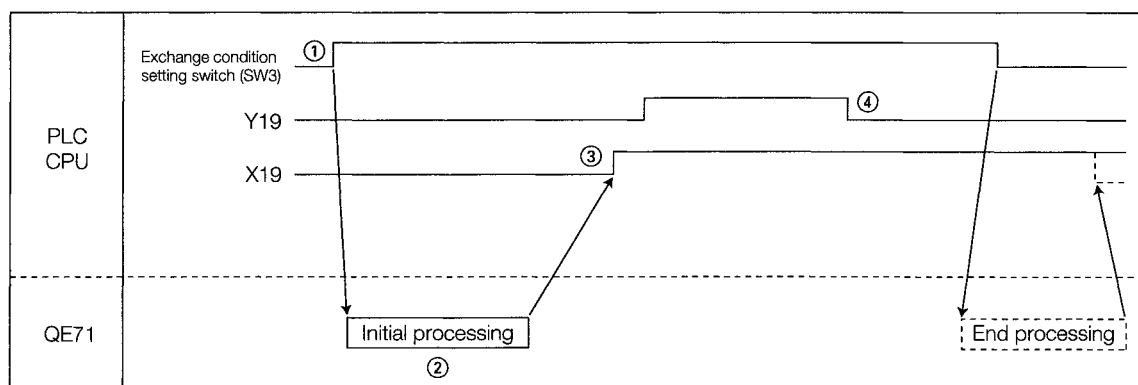

Initial processing

- ① Turns on the exchange condition setting switch (SW3: automatic start up mode setting), starts up the QE71 installation station (turns on the power, etc.), and puts the PLC CPU in the RUN state.
- ② The QE71 reads all of the setting values (parameters) registered in the EEPROM, stores them in the buffer memory, and executes initial processing. During initial processing, the initial request signal (Y19) on/off state is ignored.
- ③ The initial normal signal (X19) is turned on when the initial processing is normal end. (PING command can be sent from the remote node to the QE71) When error end, the initial error detection signal (X1A) is turned on.

End processing

- ④ The sequence program turns off the initial request signal (Y19) after checking that the next signal is off. The initial normal end signal' (X19) ON/OFF from the initial request signal off is ignored.
 - Transmission request signal/reception end check signal (Y0 to Y7)
Transmission normal end signal/reception end signal (X0,X2...)
 - Open request signal (Y8 to YF), Open end signal (X10 to X17)
Open error detection signal (X18)

When the request start up mode is changed or the setting values are changed, initial processing must be reconducted, but when an error occurs, the initial request signal (Y19) will be turned off and the exchange condition setting switch SW3 will be turned off. With this process, the QE71 conducts end processing after the close processing has been executed for the open communication line.

Remark

To exchange data between the QE71 and remote nodes by starting in auto start mode, perform the following processing in the order indicated when it is necessary to turn off the initial normal completion signal (X19) for the PLC CPU. (The A1SJ71QE71N-T and A1SJ71QE71N-B5 cannot perform this processing.)

- ① When the "Exchange while the PLC CPU is in stop" function is being used, perform writing with "Exchange prohibited while in stop" for the exchange designation area while in stop (address 103 (67H)) in the QE71's buffer memory. (Example: Writes 0) (See Chapter 16.)
- ② Terminate data exchange with all remote nodes.
 - * Turn off all of the following I/O signals for fixed buffer data exchange:
 - Transmission request signal, reception completion confirmation signal (Y0 to Y7)
 - Transmission normal completion signal, reception completion signal (X0 to XE)
 - Transmission error detection signal, reception error detection signal (X1 to XF)
- ③ Perform close processing for all connections. (See Item 5.5.)
- ④ Exchange condition setting switch SW3: Set the auto start mode setting to OFF.
 - * During the end processing of the sequence scan that implemented ④ above, processing to turn off the initial normal completion signal (X19) will be performed.

5.4.2 Example Program

This section explains an example sequence program for QE71's initial processing and end processing. Executed when fixed buffer exchange, random access buffer exchange, and reading and writing data to the PLC CPU (when automatic open UDP port is not used) from the time from when the initial request signal turns on until close processing.

(Example) The following is an example program.

- (1) The QE71 is installed in the main base's "0" slot.
- (2) The initial processing parameters are registered in the QE71's EEPROM.

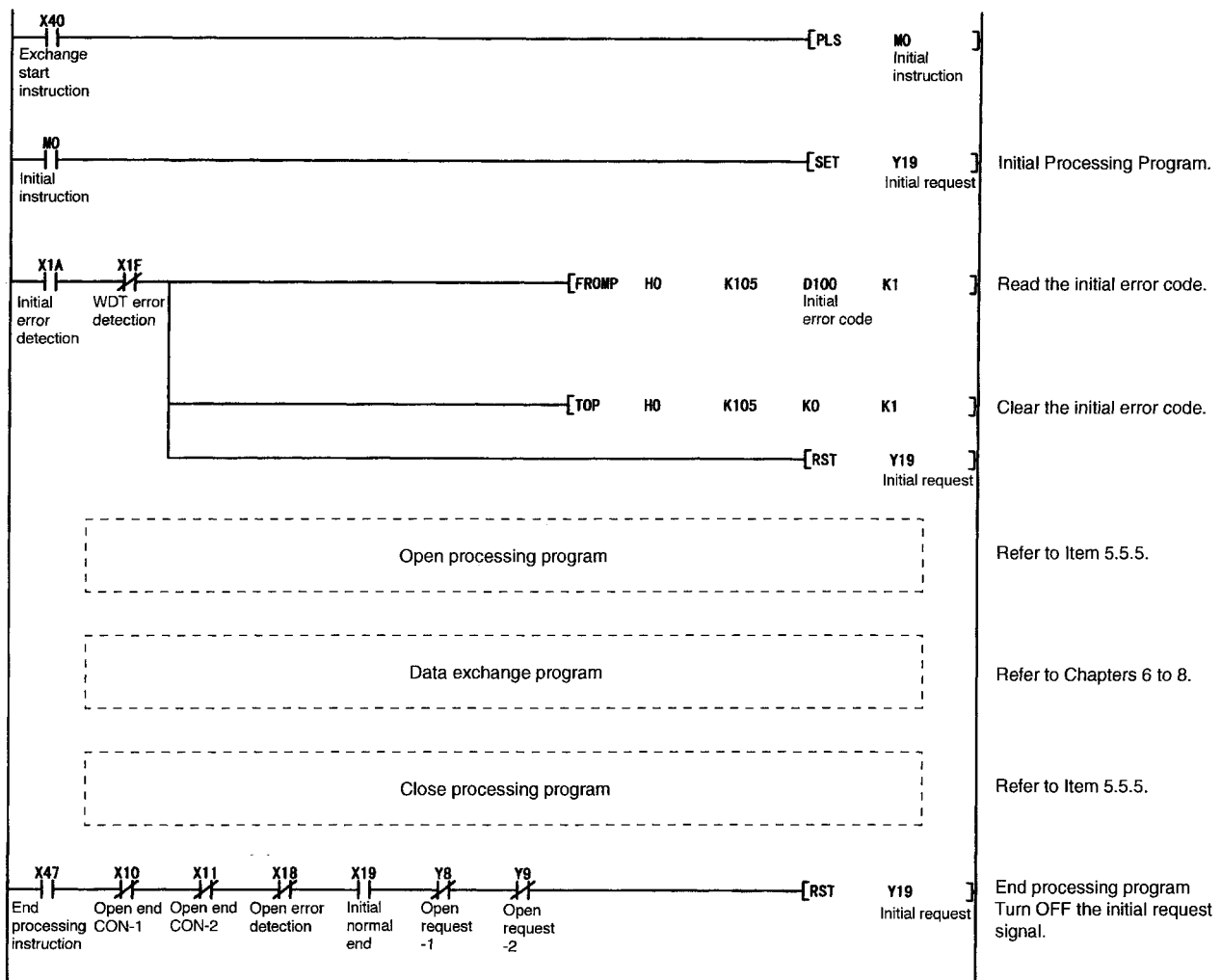

5.4.3 Confirming the Completion of Initial Processing

When the initial processing of the QE71 completes normally, the [RDY] LED indicator on the QE71 flashes.

By using any of the methods described in Item 5.3.3, the line connection status between the QE71 and remote nodes as well as the completion status of the QE71's initial processing can be checked.

5.5 Communication Line Open and Close

It is possible to exchange data at the same time with a maximum of 8 stations' remote nodes for a communication line connected by the sequence program.

The communication line can conduct fixed buffer exchange, random access buffer exchange, and reading and writing data to the PLC CPU exchange for open remote nodes. However, open processing is required when only random access buffer exchange and reading and writing data in the PLC CPU is performed.

Following is the QE71's communication line open processing and close processing performed by the PLC CPU to exchange data between the QE71 and remote nodes.

Remarks

(1) When the sequence program connects a communication line and exchanges, the communication format can be selected during open processing using the following functions.

For each port, please specify whether TCP/IP or UDP/IP will be used for exchange.

The following communication formats cannot be selected by the user.

- When exchanging by automatic open UDP port after completion of QE71 initial processing.
- When transferring a file (FTP server function)

The relationship between the QE71 data exchange functions and the communication formats are shown below.

	Exchange functions		Communication method		Remarks
			TCP/IP	UDP/IP	
Communication format for the exchange functions that connect the communication line from the sequence program (User selected)	Fixed buffer exchange	With procedure	○	○	—
		Without procedure	○	○	
	Random access buffer exchange		○	○	
	Read/write data in the PLC CPU (General data exchange)	QE71 command exchange	○	○	When the automatic open UDP port is not used.
		E71 command exchange	○	○	
Router relay exchange		○	○	—	
MELSECNET/10 relay exchange		○	○	UDP/IP is used for exchange between QE71's that serve as relays.	
Communication format for the functions to be enabled upon completion of QE71's initial processing (Exchange using the automatic open UDP port)	Read/write data in the PLC CPU (General data exchange)	QE71 command exchange	×	○	UDP/IP is used for exchange between QE71's that serve as relays. The communication format cannot be selected by the user.
		E71 command exchange	×	○	
	Remote station access using data link commands		×	○	
	Router relay exchange		×	○	
MELSECNET/10 relay exchange		×	○		
Communication format for the functions to be enabled upon completion of QE71's initial processing	File transfer (FTP server function)		○	×	The communication format cannot be selected by the user.

(2) Normally, in networks that use IP address, data is exchanged with remote nodes that are part of the same network (subnet address is the same) as that of the local station. When data is exchanged with a remote node from a different network (different subnet address) via a router, the exchange is possible via a router or gateway by TCP/IP active open of the PLC CPU side or UDP/IP transmission. (When exchange with a partner remote node via a router is done with the QE71 in passive open, exchange can be done without using router relay functions.)

5.5.1 Data for Opening

This section explains about the exchange parameter settings area used to conduct communication line open processing. (Refer to Item4.8 5) about whether the parameter should be set.)

		Buffer Memory		
(Address)		Exchange parameter settings area (64 Words)		Default value
20H (32)	Connection No. 1	Usage available settings area (1 word each)	0H (0)
21H (33)	Connection No.2		0H (0)
22H (34)	Connection No.3		0H (0)
23H (35)	Connection No.4		0H (0)
24H (36)	Connection No.5		0H (0)
25H (37)	Connection No.6		0H (0)
26H (38)	Connection No.7		0H (0)
27H (39)	Connection No.8		0H (0)
28H (40)	QE71's port No.	Exchange address settings area (connection No.1 7 words)	0H (0)
29H (41)	Remote node IP address		0H (0)
2AH (42)	Remote node port No.		0H (0)
2BH (43)	Remote node (L)		FFFFFFFFFFFH
2CH (44)	Remote node to		
2DH (45)	Ethernet to		
2EH (46)	address (*1) (H)		
2F to 35H (47 to 53)		QE71's port No. to		Exchange address settings area (connection No.2 7 words)
36 to 3CH (54 to 60)		QE71's port No. to	Exchange address settings area (connection No.3 7 words)	(Same as connection No.1)
30 to 43H (61 to 67)		QE71's port No. to	Exchange address settings area (connection No.4 7 words)	(Same as connection No.1)
44 to 4AH (68 to 74)		QE71's port No. to	Exchange address settings area (connection No.5 7 words)	(Same as connection No.1)
4B to 51H (75 to 81)		QE71's port No. to	Exchange address settings area (connection No.6 7 words)	(Same as connection No.1)
52 to 58H (82 to 88)		QE71's port No. to	Exchange address settings area (connection No.7 7 words)	(Same as connection No.1)
59H (89)	QE71's port No.	Exchange address settings area (connection No.8 7 words)	0H (0)
5AH (90)	Remote node IP address		0H (0)
5BH (91)	Remote node port No.		0H (0)
5CH (92)	Remote node (L)		FFFFFFFFFFFH
5DH (93)	Remote node to		
5EH (94)	Ethernet to		
5FH (95)	address (*1) (H)		

*1 If the partner remote node connected by the communication line has an ARP function (broadcast), please make the default value (FFFFFFFFFFFH).

1 Usage available settings area (Default value = 0H) Address 20H to 27H (32 to 39)

- (a) Set the fixed buffer usage availability for open processing to whether or not to perform destination existence check.
- (b) Conduct this setting before open processing for each connection.

(Bit position)	b15	b14	b13	b12	b11	b10	b9	b8	b7	b6	b5	b4	b3	b2	b1	b0
(For memo)	⑥	0					⑤	④	③	0					②	①

- ⑥ Open method
00: Active, UDP/IP
10: Unpassive
11: Fullpassive
- ⑤ Fixed buffer exchange
0: With procedure
1: Without procedure
- ④ Communication format
0: TCP/IP
1: UDP/IP
- ③ Pairing open
0: No Pairs
1: Pairs
- ② Existence check
0: No check
1: Check
- ① Fixed buffer usage
0: For transmission/
does not communicate
1: For reception

① Fixed buffer usage availability setting (b0)

- When conducting exchange using a fixed buffer, set whether the fixed buffer will be used for transmission or reception for the corresponding connection.
- Specify one of the following setting values.
0 : For transmission or not to perform fixed buffer exchange (default value)
1 : For reception
- When conducting transmission and reception using one specific node and fixed buffer, two fixed buffers are required for transmission and reception, so please set two connections.
- From remote node, random access buffer exchange and reading and writing data to the PLC CPU exchange can be conducted by either reception setting or transmission setting for usage of fixed buffer.

② Destination existence check setting (b1)

- Set the QE71 to check whether the partner remote node is operating normally when exchange with the partner remote node for its connection open processing as ended has not been conducted for a specific period of time. (*2 Refer to Item 5.2.2)
- Specify one of the following specification values.
0 : Does not check existence (no check) (default value)
1 : Checks existence (has check)

* When existence check is selected, the QE71 conducts an existence check for the destination at each specified time interval to check whether the connection destination (partner destination) is operating correctly. The QE71 will conduct the following process if an error occurs during the existence check.

- Force closes the line and stores the error information in the buffer memory error log area (address 224 to 511).
- The open error detection signal (X18) is turned on when the open end signal (X10 to X17) is turned off.
- When changing the exchange partner remote node during the middle of an operation at the UDP/IP connection, make the setting 0 (Does not check existence).
When 1 (check existence) is set, the QE71 conducts an existence check on the first exchange partner after UDP/IP open. An existence check is not performed for exchange partners after the change.
- Set 0 (Does not check existence) when sending simultaneous broadcasting with in a exchange that uses the without procedure fixed buffer.

③ Pairing open setting (b7)

- Sets whether one of the partner remote nodes' ports is connected when the QE71 reception connection and transmission connection are made into one pair when fixed buffer exchange (either with procedure or without procedure can be selected) is conducted.

(Example)

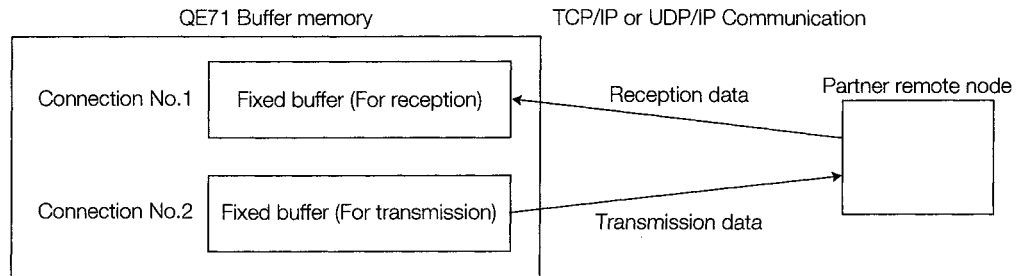

- When pairing opening is set, the corresponding connection No.'s fixed buffer (for reception) and the next connection No.'s fixed buffer (for transmission) are paired. (When the connection No. to be opened is "8," the connection No.8's fixed buffer is used for reception, and the connection No.1's fixed buffer is used for transmission.)

The usage availability settings are conducted as follows.

The connection No. to be used for reception: $b0 = 1$ (for reception), $b7 = 1$ (opens pairing)

For transmission connection No: (The usage availability settings are not required)

- The user opened processing, done during pairing setting, is performed for the reception connection No.

The open processing for the pairing transmission connection No. (open request signals on) is not required. (QE71 conducts automatically.)

The open process for the reception connection No., turns on the transmission connection No.'s open end signal.

- An image of open processing when pairing open is set up is shown in Remark in Item 5.5.4.
- Specify one of the following setting values for pairing open setting (b7).
0 : Does not open pairing (default value)
1 : Opens pairing

- ④ Communication format (protocol) settings (b8)
- Sets whether TCP/IP or UDP/IP is used as the communication protocol for each connection.
 - Select one of the following setting values.
 - 0 : TCP/IP (default value)
 - 1 : UDP/IP
- ⑤ Fixed buffer exchange procedure existence setting (b9)
- Sets the exchange method used to conduct fixed buffer exchange.
 - Specify one of the following setting values.
 - 0 : With procedure (default value)
 - 1 : Without procedure
- * When with procedure is selected, in the corresponding connection, fixed buffer exchange with procedure, random access buffer exchange, and reading and writing data in the PLC CPU exchange can be conducted. When without procedure is selected the corresponding connection becomes a without procedure fixed buffer exchange special use, so fixed buffer exchange with procedure, random buffer exchange, and reading and writing data to the PLC CPU exchange cannot be conducted at the same time as exchange without procedure.
- ⑥ Open method setting (b14, b15)
- This setting is valid only when the communication format (protocol) is TCP/IP.
 - Setting is not required when UDP/IP is the communication method, so make the setting "00."
 - When opening using TCP/IP, open the active open node after the Full passive/Unpassive open node open processing end.

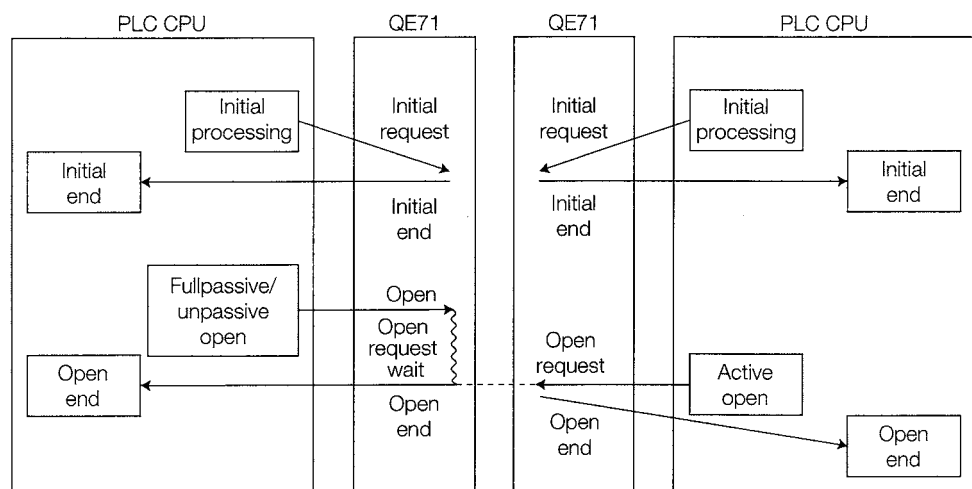

- Specify one of the following settings.
 - 00 : Active open or UDP/IP (default value)
 - 10 : Unpassive open
 - 11 : Full passive open

Remarks

Shows the differences between each open format.

① Active open format

Conducts active open processing for the remote nodes that are in the TCP connection open passive state (Full Passive/Unpassive open state).

② Full passive open format

Conducts TCP connection passive open processing for only the specified nodes that are set in the exchange address setting area. Changes to the Active open request wait state from the remote node that is set in exchange address setting area.

③ Unpassive open format

Conducts TCP connection passive open processing for all the remote nodes connected to the network. All the remote nodes in the network change to the Active open request wait state.

(c) Following is an example of the usage available setting area data setting.

(Bit position)	b15	b14	b13	b12	b11	b10	b9	b8	b7	b6	b5	b4	b3	b2	b1	b0
	⑥			0			⑤	④	③			0			②	①

- ① Fixed buffer usage availability
- ② Destination existence check
- ③ Pairing open setting
- ④ Communication format
- ⑤ Fixed buffer exchange procedure existence
- ⑥ Open method setting

(Example 1) When set to ③ is "0" (Pairing open not done), ⑤ is "0" (with procedure).

		④ : 0(TCP)			④ : 1 (UDP)
		⑥ : 00 (Active)	⑥ : 10 (Unpassive)	⑥ : 11 (Full passive)	
① : 0 (For transmission)	② : 0 (Does not check)	0000H	8000H	C000H	0100H
	② : 1 (Checks)	0002H	8002H	C002H	0102H
① : 1 (For reception)	② : 0 (Does not check)	0001H	8001H	C001H	0101H
	② : 1 (Checks)	0003H	8003H	C003H	0103H

(Example 2) When ③ is "0" (Pairing open not done), ⑤ is "1" (without procedure).

		④ : 0(TCP)			④ : 1 (UDP)
		⑥ : 00 (Active)	⑥ : 10 (Unpassive)	⑥ : 11 (Full passive)	
① : 0 (For transmission)	② : 0 (Does not check)	0200H	8200H	C200H	0300H
	② : 1 (Checks)	0202H	8202H	C202H	0302H
① : 1 (For reception)	② : 0 (Does not check)	0201H	8201H	C201H	0301H
	② : 1 (Checks)	0203H	8203H	C203H	0303H

(Example 3) ③ is "1" (Pairing open is done), ⑤ is "0" (with procedure) is set.

		④ : 0(TCP)			④ : 1 (UDP)
		⑥ : 00 (Active)	⑥ : 10 (Unpassive)	⑥ : 11 (Full passive)	
① : 1 (For reception)	② : 0 (Does not check)	0081H	8081H	C081H	0181H
	② : 1 (Checks)	0083H	8083H	C083H	0183H

(No setting is required on the transmission connection side)

2 Exchange address setting area

- (a) Sets the local station QE71's port No. partner remote node IP address, port No., etc., when communication line is connected using open processing.
- (b) For the setting values, please specify the values set by the network manager.
- (c) Sets the data in accordance with the contents of the usage availability setting area's open procedure settings (b14, b15) shown in **1** when settings are conducted for each connection. (refer to Point in Item 3.7.2) Sets these settings before open processing is conducted during TCP open, open processing is conducted before UDP open processing, and before data transmission and reception.

① QE71's port No. setting (Default value = 0H): Address 28H (40...)

- Sets the local station QE71's port No.
- The setting values are specified to between 401H and 1387H (1025 to 4999) or between 138BH and FFEH (5003 to 65534). Set to No. that is not being used elsewhere. (Port No.5001 and 5002 is used by the QE71 system, so it cannot be specified.)
- Following are the precaution items for port Nos. when multiple connections are made between remote nodes and the local station using open processing. (In the diagram, the nodes are denoted by a square, and the port Nos. are denoted by the circles.)

Connection state (○: Port (Port No.))	Connection description	Communication protocol	
		TCP	UDP
	Also sets multiple local station port Nos. even though connections are made with multiple nodes.	○	○
	Sets a single local station port No. when connections are made with multiple nodes. (However, several connections must be opened.) Can not perform this when the local station is unpassive.	○	×
	Also sets multiple QE71 port Nos. even though connections are made with multiple remote node ports.	○	○
	Sets a single QE71 port No. even though connections are made with multiple remote nodes. (However, several connections must be open.) Can not perform this when the local station is unpassive.	○	×
	Sets multiple QE71 port Nos. even though connection is made to the same remote node port. (However, several connections must be open.)	○	○
	Multiple settings when the remote node same port and the QE71's same port is only possible for pairing open settings.	○	○

- ② Remote node IP address setting (Default value = 0H)
Address 29H to 2AH....(41 to 42...)
 - Sets the IP address for the partner remote node for which exchange will be done.
 - Specify the settings value as other than 0H and FFFFFFFFH except when simultaneous broadcast communication is performed with exchange without procedure (UDP/IP) by fixed buffer. (FFFFFFFH is the setting value for the simultaneous broadcast communication described above.) Before setting, check the partner remote node's IP address.
- ③ Remote node port No. setting (Default value = 0H) Address 2BH....(43...)
 - Sets the port No. for the primary remote node for which exchange will be done.
 - Specify the settings value as between 401H and FFEH except when simultaneous broadcast communication is performed with exchange without procedure (UDP/IP) by the fixed buffer. (FFFH is the setting value for the simultaneous broadcast communication described above.) Before setting, check the partner remote node's port No.
- ④ Remote node Ethernet address setting (Default value = FFFFFFFFH)
 Address 2CH to 2EH....(44 to 46...)
 - When the partner remote node which exchange is being conducted does not have ARP functions, set the partner remote node's Ethernet address.
 - Set the settings values to those shown below.
 When the partner remote node has ARP functions 0H or FFFFFFFFH
 When the partner remote node does not have ARP functions
 Partner remote node's Ethernet address (except 0H and FFFFFFFFH)
 When specifying other than 0H and FFFFFFFFH, check the partner remote node's Ethernet address before making the settings.
 - * When this setting value is 0H or FFFFFFFFH, the QE71 conducts processing as if the partner remote node has ARP functions.
 (Example) The settings data when the Ethernet address is 080070220004H is shown below. (For connection No.1)

Address	Buffer Memory
2CH(44)	0004H
2DH(45)	7022H
2EH(46)	0800H

← Write □ 0800H □ 7022H □ 0004H
 D117 D116 D115

3 Relationship with the parameter setting values when functions are used

The relationship between the functions and the exchange parameter setting values when QE71 functions are used is shown in 4.8 **5**.

Point

- (1) The open processing exchange parameter setting area's setting values are registered in the QE71's EEPROM. The values registered in the EEPROM can be used as the default values when the QE71 is booted up.
- (2) Determine the setting values by consulting with the partner equipment and the system's managers.
- (3) For information regarding the parameters required for setting when QE71 open processing is conducted when QE71 functions are used, refer to Item 4.8 **5**.

5.5.2 Communication Line Open Processing Procedure

This section explains the open processing procedure for connecting a communication line from the QE71 to a remote node using an example for connection No.1.

To conduct open processing, initial processing must be completed.

1 Open processing procedure using TCP

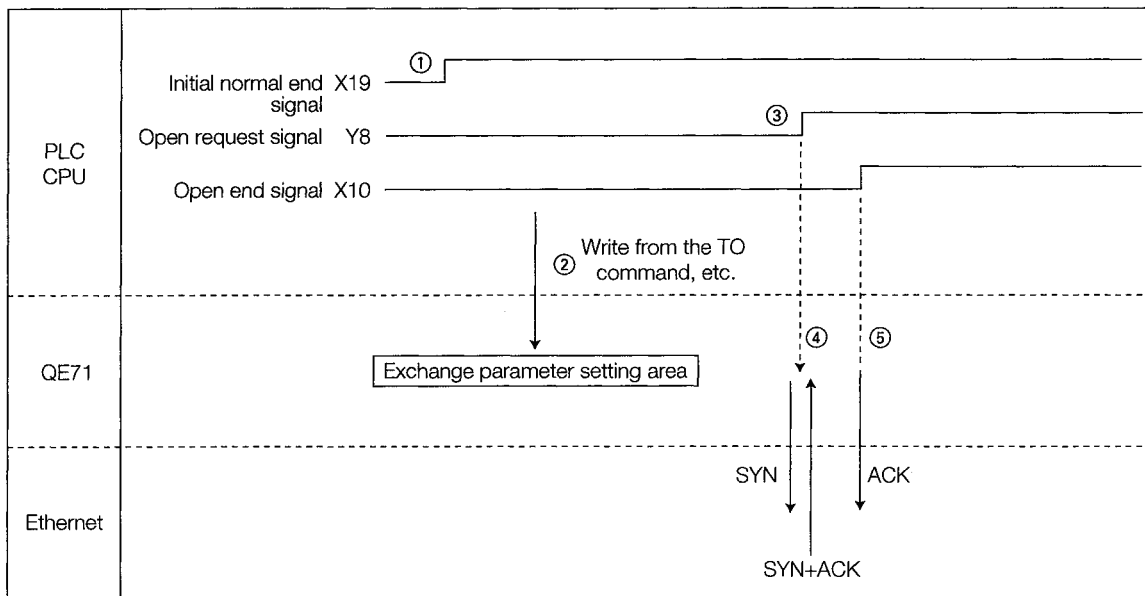

2 Open processing procedure using UDP

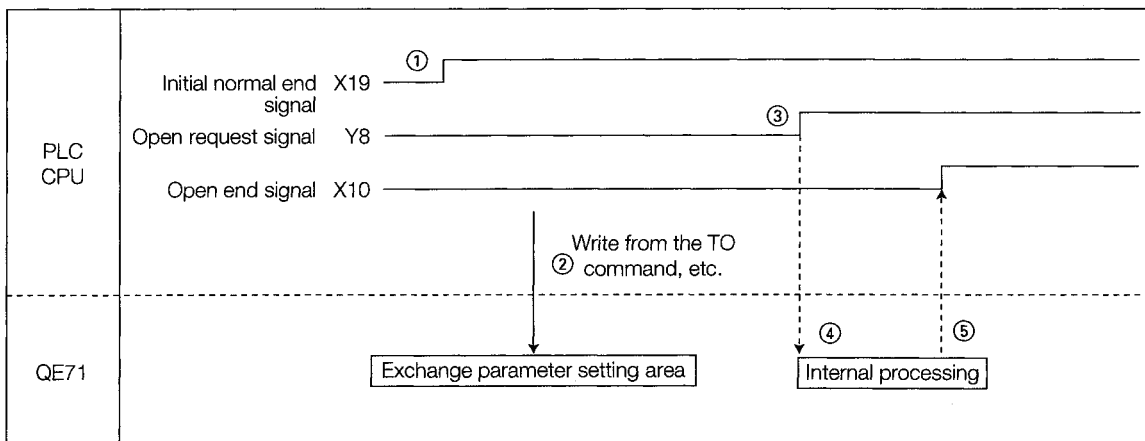

① Initial processing is conducted by the initial request signal (Y19) or by turning on the exchange condition setting switch (SW3: automatic start up mode setting). Initial normal end signal (X19) turns on. (Refer to Items 5.3 and 5.4)

② The TO command, etc., causes the sequence program to write the setting values (parameters) in the buffer memory exchange parameter settings area. (These can also be read from the EEPROM using the functions described in Item 5.8.)

* Registering the settings values in the QE71's EEPROM reads all of the setting values into the buffer memory from the EEPROM when the QE71 is started up, so a write from the sequence program is not necessary.

- ③ The open request signal (Y8) is turned on by the sequence program.
- ④ The QE71 executes the open processing. (*1)
 (For TCP)
 For Active open Open request (SYN) is transmitted. (*2)
 For Passive open An open request from the partner remote node is waited. (*3)
 (No time out check Infinite wait)
- (For UDP)
 Executes internal processing.
- ⑤ The open end signal (X10) is turned on when the open processing/internal processing is normal end.
- The open error code is stored in the buffer memory and the open error detection signal (X18) is turned on when the open processing/internal processing is error end. (*4)
 (The open end signal (X10) does not turn on.)
- If the open request signal is turned OFF while an open error is generated, the open error detection signal will be off as long as no open error is present in other line connections. (If the open request signal (Y8 to YF) is off for all connections in which an open error is currently occurring, the open error detection signal (X18) is turned off.)
- *1 When the initial request signal (Y19) is off, exchange condition setting switch (SW3: automatic start up mode setting) is off, or the open request signal (Y8) is turned off during open processing, closed processing and end processing are performed after the open processing end.
- *2 When an active open is performed and an ABORT (RST) instruction is received from the partner remote node, the open processing will complete abnormally and the open error detection signal (X18) will turn on.
- *3 When a passive open is performed and the open request signal is turned off prior to completing the open processing, the open request will be invalid.
- *4 The open state and error codes during error end are checked by the next buffer memory.
- The exchange state storage areas (information storage area by connection: address 120 to 199) open error code area.
 - Error log area (error log block error code storage area: address 229...).
- The error codes stored in the open error code area will be cleared (n→0) when the open request signal is turned ON again.

5.5.3 Communication Line Close Processing Procedure

This section explains the close processing for closing (disconnecting) the communication line that was connected between the QE71 and the remote node by open processing using an example for connection No.1.

The close processing timing must be conducted by making arrangements with the partner remote node.

1 For closing from the QE71 end

(a) Close processing procedures using TCP

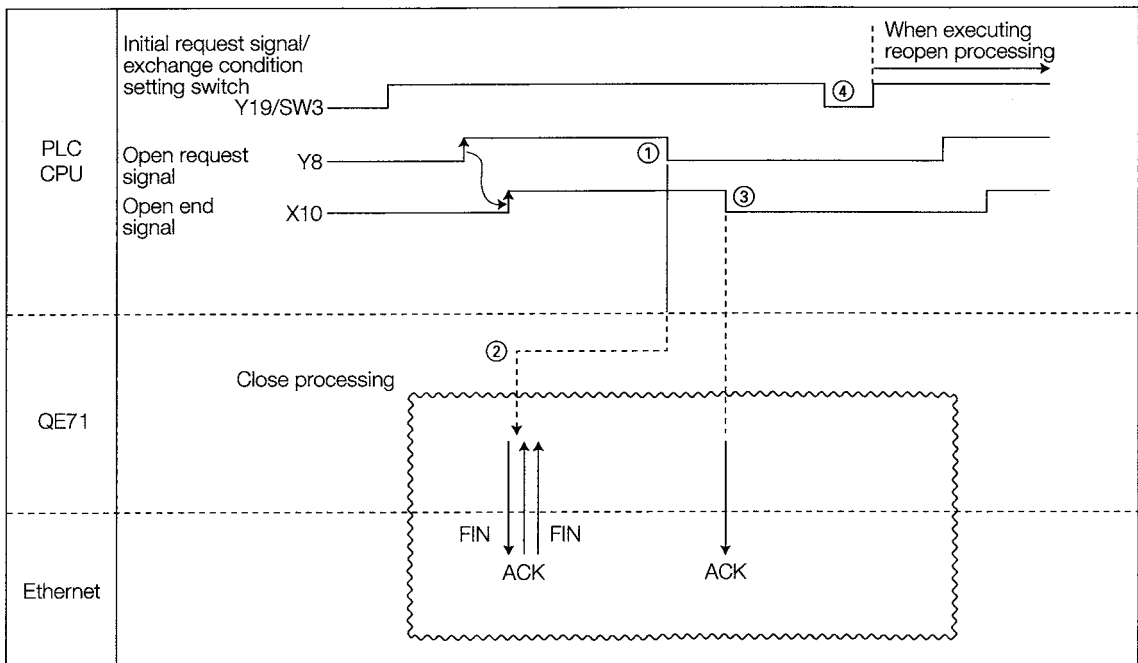

(b) Close processing procedures using UDP

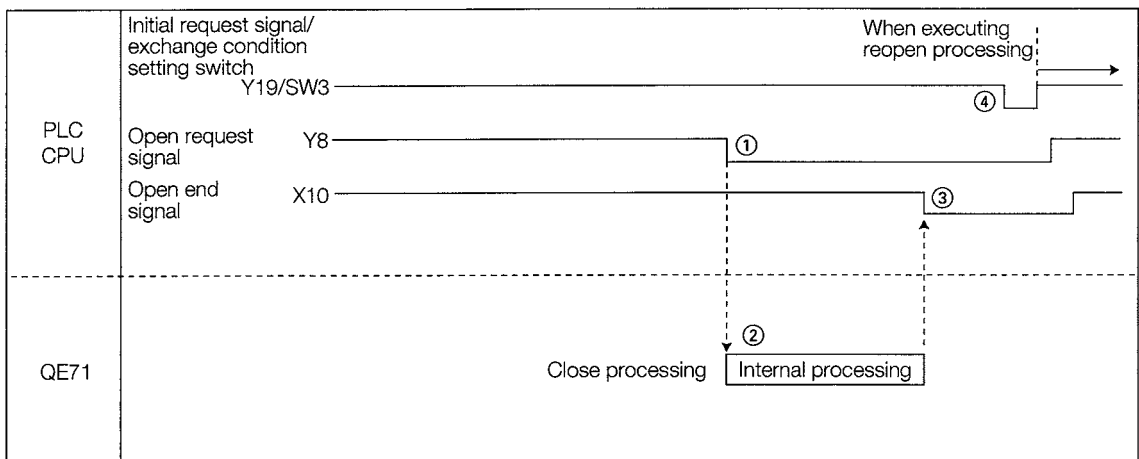

- ① The open request signal (Y8) is turned off by the sequence program.
- ② The QE71 executes close processing.
 - * If the transmission request signal/reception completion confirmation signal (Y0, Y1...) for the fixed buffer communication of the corresponding connection is off when the open request signal (Y8, Y9...) is turned off, the QE71 turns off the corresponding input signal (X) listed below:
 - Transmission normal completion signal/reception completion signal (X0, X2...)
 - Transmission error detection signal/reception error detection signal (X1, X3...)(Example: For connection 1)

If the transmission request signal/reception completion confirmation signal (Y0) for connection 1 is off when the open request signal (Y8) is turned off, the QE71 turns off the following input signals (X).

 - Transmission normal completion signal/reception completion signal (X0)
 - Transmission error detection signal/reception error detection signal (X1)
- ③ When close processing ends the open end signal (X10) turns off for either normal close or error close. (The open request signal (Y8) can be turned on immediately after the open end signal (X10) turns off.)
- ④ Initial request signal (Y19) is turned off by the sequence program.

Point

The open end signal (X10 to X17) is automatically turned off and the communication line will be closed in the following cases in addition to a close request. To reopen, first turn off the open request signal (Y8 to YF) once, and then conduct open processing.

(1) When the exchange condition setting switch (SW1: line processing selection when TCP ULP timeout error) is set to off (close), the open end signal will turn off when the following timeout occurs.

- ① Timeout during TCP transmission
- ② Partner remote node existence check function timeout

At this time the open error detection signal (X18) turns on. (*1)

* When the exchange condition setting switch SW1 is set to on (does not close), the line will not close even when the above timeout occurs. (The open error detection signal (X18) will not turn on.) However, the error code will be stored in the buffer memory described in *1 below.

(2) The open end signal will turn off when a close or ABORT (RST) command is received from the partner remote node.

(3) The open end signal will turn off when transmission of ABORT (RST) command is conducted. At this time, the open error detection signal (X18) will turn on. (*1)

(4) When the active open request is received again from the partner remote node with the TCP connection completely open

The operation varies depending on the QE71 version.

(a) When the software version of the QE71 is "Version E" or later

The QE71 closes the connection when it receives the RST command from the partner remote node after returning ACK to the partner remote node.

(b) When the software version of the QE71 is "Version D" or earlier

The QE71 closes the connection after sending the RST command.

However, the QE71 only sends the RST command when it receives the active open request again from the partner remote node with a different IP address or port No. (Does not close the connection.)

(5) The open end signal will turn off when the QE71's ABORT (RST) command is transmitted including that described above (Refer to Item 3.5.3).

*1 When the open request signal (Y8 to YF) turns off, the open error detection signal (X18) turns off. In addition, the open state and the error code during error end can be checked using the following buffer memory.

- Exchange state storage area (information storage area by individual connection: address 120 to 199) open error code area
- Error log error (error log block error code storage area: address 229...)

The error codes stored in the open error code area will be cleared (n→0) when the open request signal is turned ON again.

(c) Processing (TCP) when error end is done by close

Normally, when closed by the QE71, the QE71 transmits FIN and then ACK, FIN are returned from the partner remote node. However, when ACK, FIN are not returned because of a partner remote node error, the QE71 forcefully disconnects the connection (transmission of ABORT (RST) command).

Following is an explanation that uses an example of processing for connection No. 1.

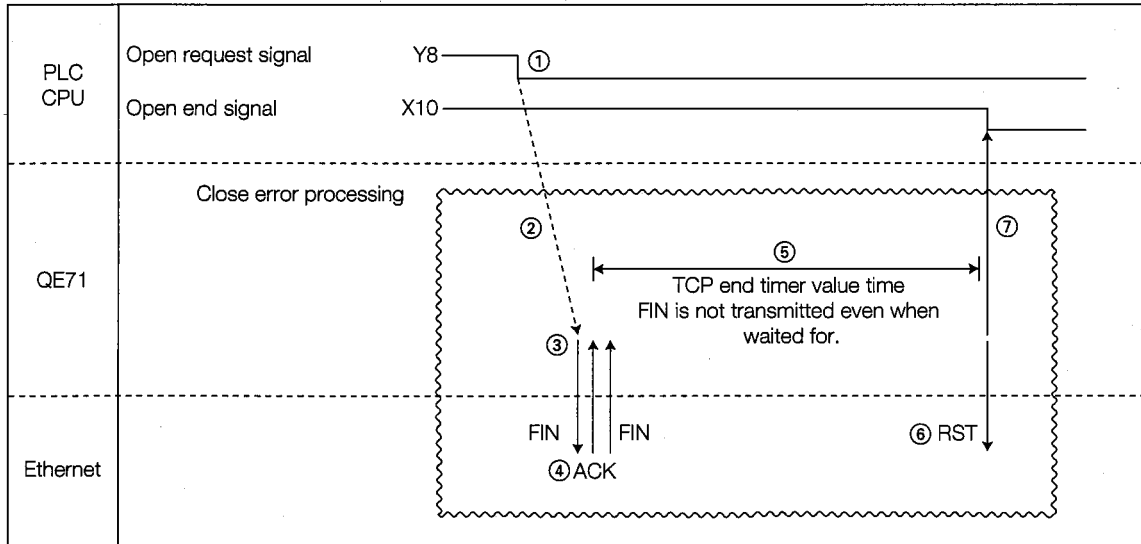

- ① The open request signal (Y8) is turned off by the sequence program.
- ② The QE71 begins close processing.
- ③ The QE71 transmits FIN to the partner remote node.
- ④ The partner remote node returns ACK and FIN in response to the FIN sent by the QE71.
(If not returned, the QE71 retransmits the FIN.)
In response to the FIN sent by the QE71, if an ACK RST is sent back from the other node, the QE71 determines that the close processing is completed and turns OFF the open completion signal.
- ⑤ The QE71 waits for ACK and FIN to be transmitted by the partner remote node.
(The wait time is the TCP end timer value time.)
At this time, if ACK and FIN are transmitted, ACK will be returned as normal processing.
- ⑥ If the ACK and FIN are not transmitted within the TCP end timer value time, ABORT (RST) command is transmitted to the partner remote node.
- ⑦ The QE71 determines that close processing has ended regardless of the state of the partner remote node, and turns the open end signal (X10) to off.

Remarks

- (1) When the above processing is conducted, the QE71 determines that the partner remote node processing was conducted normally, so the close results are not stored in the error log area.
- (2) The above processing is a unique function of the QE71, and is not part of the general TCP/IP protocol.

2 When closing from the partner remote node end

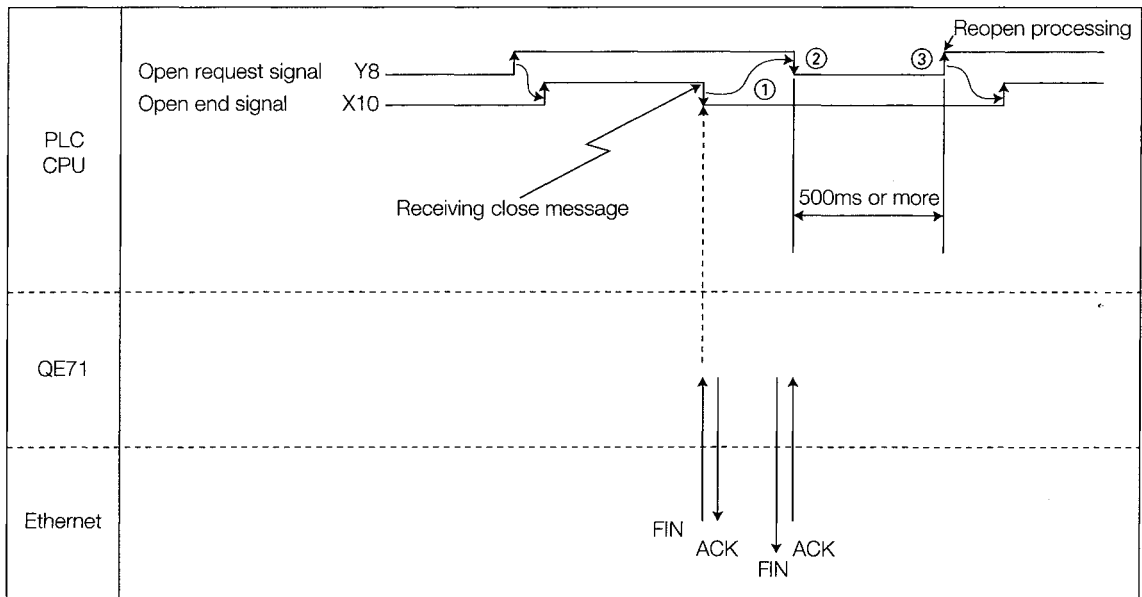

- ① The open end signal (X10) is turned off when the close/ABORT (RST) command is received from the partner remote node.
- ② The open request signal (Y8) is turned off by the sequence program when the open end signal is turned off.
- ③ When reopening the open request signal (Y8) is turned on by the sequenc program after a minimum of 500ms.

Point

For the sequence program to recognize the open end from the remote node side the open end signal (X10 to X17) on time must be longer than the PLC CPU's scan time. Even if there is an open end, if a close message is received that is shorter than the QnACPU scan time, the sequence program may not recognize the open end.

Remarks

With communication in the connection 1 as an example, the following shows the timing chart for performing reopen processing when an error has occurred in fixed buffer data exchange via TCP/IP communication and the open completion signal turns off.

1 When all input signals for data exchange turn off normally

* A program example is shown in Item 5.5.5.

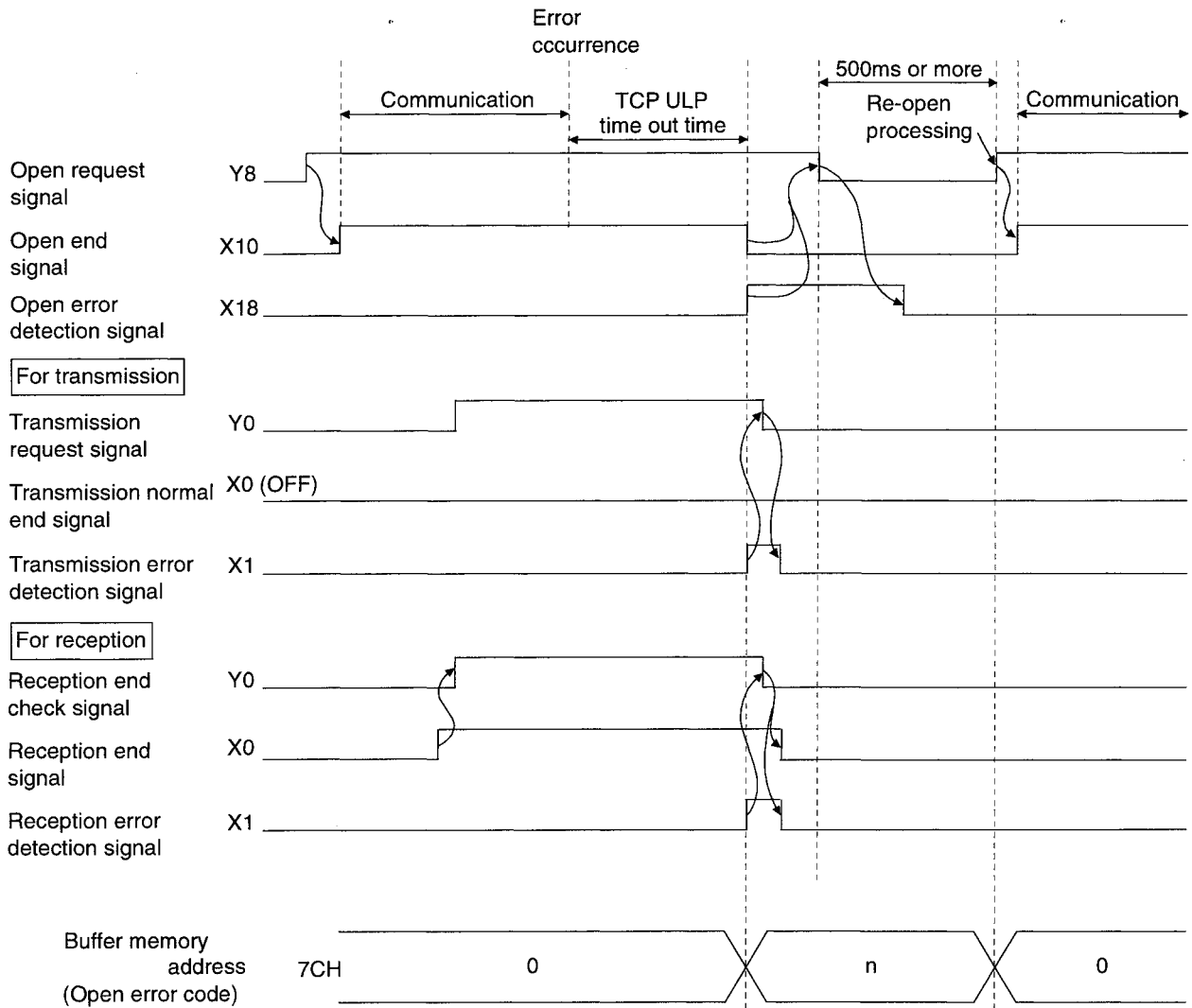

2 When all input signals for data exchange do not turn off

The QE71 performs close processing even if the following signals for the fixed buffer data exchange for the corresponding connection are on when the reception of Close/Abort (RST) has occurred from the partner remote node prior to the completion of data communication performed immediately before.

- Transmission request signal/reception completion confirmation signal (Y0 to Y8)
- Transmission normal completion signal/reception completion signal (X0, X2...)
- Transmission error detection signal/reception error detection signal (X1, X3...)

If close processing is performed for the corresponding connection while the above signals are on, turn off the open request signal (Y8 to YF) after turning off the transmission request signal/reception completion confirmation signal at the timing shown below. The QE71 turns off the above input signals of the corresponding connection.

* A program example is shown in Item 7.2 of Appendix.

* If pairing open has been performed for the corresponding connection, the signal that was specified when opening will be the target open request signal for the input/output signals shown in the figure below.

For transmission (when closed by the partner node)

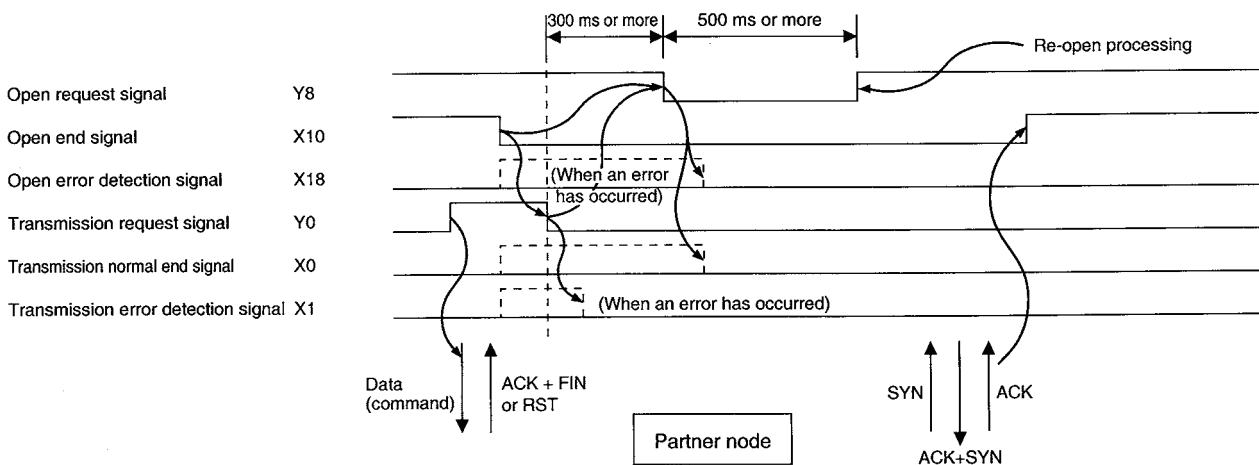

For reception (when closed by the partner node)

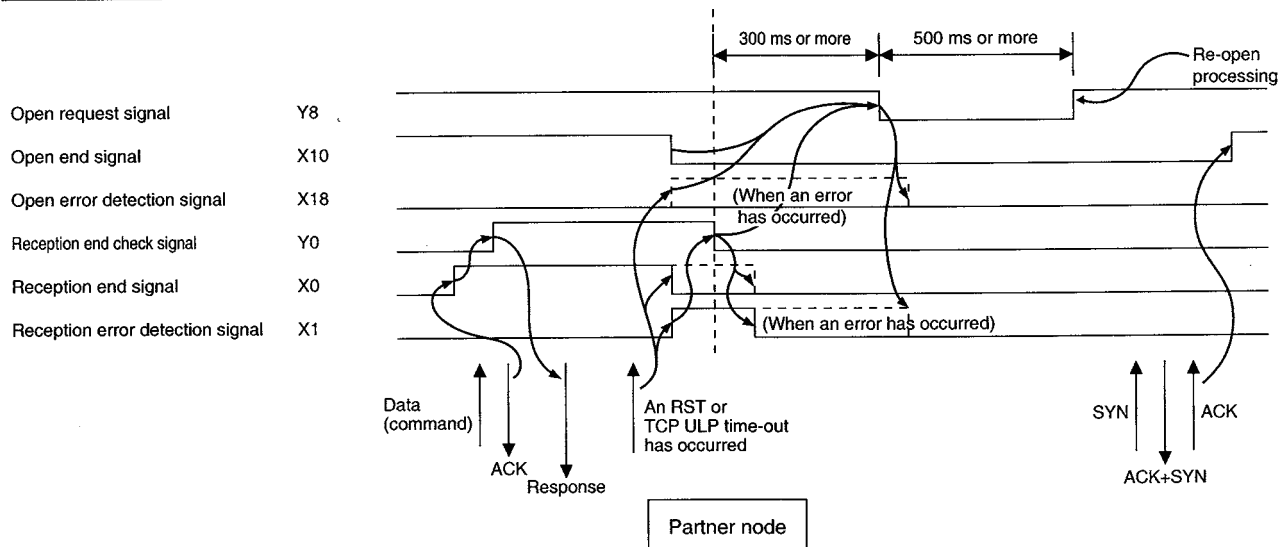

5.5.4 Pairing Open Communication Line Open Processing and Close Processing Procedures

This section explains the open processing and close processing procedures when connecting a communication line to one partner remote node port when the QE71's reception connection and transmission connections are made into one pair.

Fixed buffer exchange (either with procedure or without procedure is possible) is performed by the connection which the pairing open was processed.

(Example)

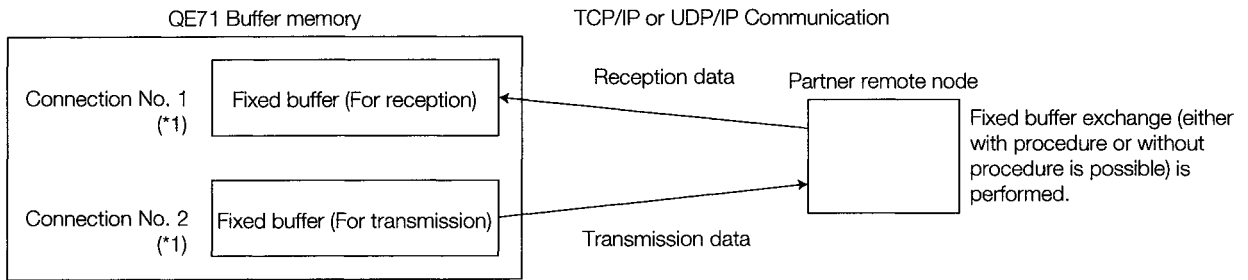

*1 Connection No.1 and No.2's exchange parameter settings (Address 20H to 21H)

- Connection No.1 exchange parameter setting value (Address 20H) : 0081H
- Connection No.2 exchange parameter setting value (Address 21H)
: Setting not required

(When the Pairing is Connection No. 1 and Connection No. 2)

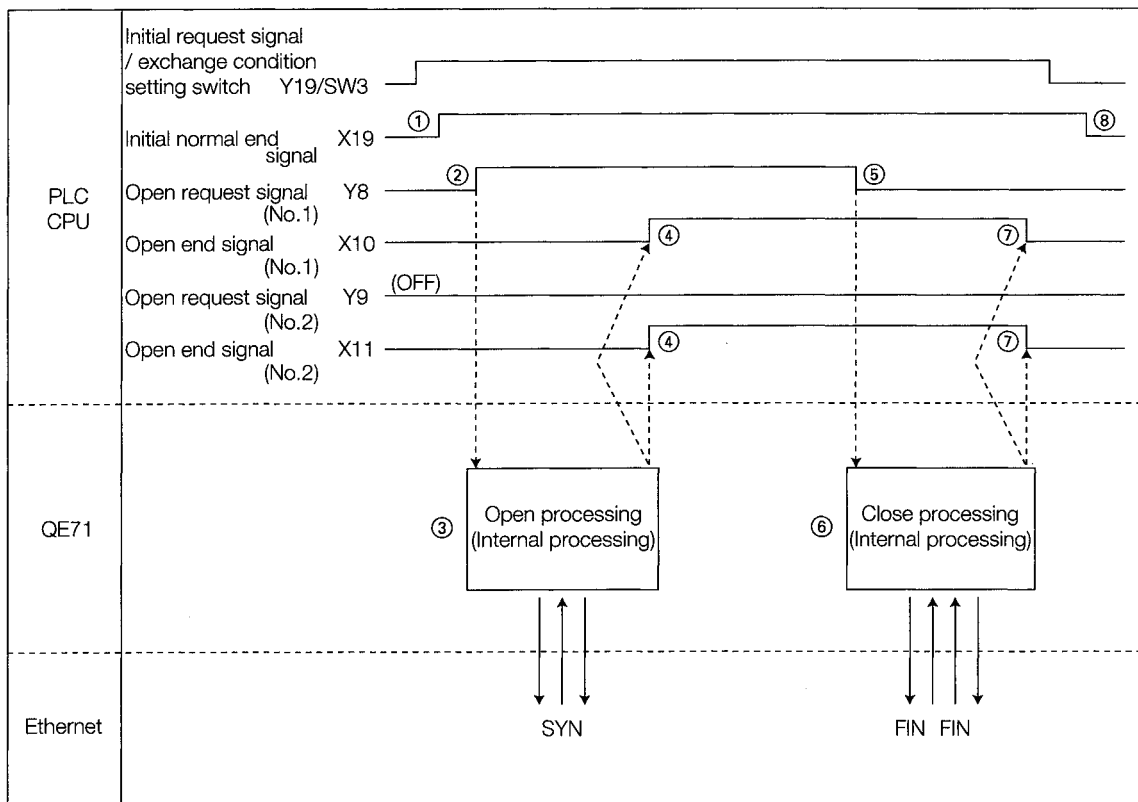

Open processing

- ① The initial normal end signal (X19) is turned on by the initial processing normal end which is produced when the initial request signal (Y19) or exchange condition setting switch (SW3: automatic start up mode setting) is turned on. (Refer to Items 5.3 and 5.4)
- ② The setting values (parameters) are written to the buffer memory exchange parameter settings area by the sequence program in response to a TO command, etc., which turns on the open request signal (Y8). (The settings values can also be read from the EEPROM using the function described in Item 5.8.)
 - * The exchange parameters registered in the QE71's EEPROM are read when the QE71 is started up by turning on exchange condition setting switch (SW3: automatic start up mode setting) so writing from the sequence program is unnecessary.
- ③ The QE71 executes open processing for connection No.1 and connection No.2. (*1)
 - (For TCP)
 - For Active open: Transmits open request (SYN).
 - For Passive open: Waits for an open request from the partner remote node.
 - (For UDP)
 - Internal processing is executed.
- ④ Open end signal (X10, X11) is turned on when the open processing/internal processing is normal end.
 - The open error code is stored in the buffer memory and the open error detection signal (X18) is turned on when the open processing/internal processing is error end.
 - (The open end signal (X10, X11) is not turned on. Refer to Item 5.5.2 *4)
 - If the open request signal is turned off when an open error occurs, the open error detection signal turns off unless an open error has occurred in other line connection.
 - (If the open request signal (Y8 to YF) for all connections in which an open error is currently occurring is off, the open error detection signal (X18) is turned off.)
 - *1 When the initial request signal (Y19) is off, exchange condition setting switch (SW3: automatic start up mode setting) is off, or the open request signal (Y8) is turned off after open processing when data reception/transmission are not performed, closed processing and end processing are performed after the open processing end.

Close processing

- ⑤ The open request signal (Y8) is turned off by the sequence program.
- ⑥ The QE71 executes close processing for connection No.1 and connection No.2.
- ⑦ The open end signal (X10, X11) is turned off when the close processing ends.
- ⑧ The initial request signal (Y19) is turned off by the sequence program.

Point

- (1) It is not necessary to set the exchange parameters for the second connection No. if two connections are specified to be opened as a pair (the setting is ignored).
Please refer to Item 5.5.1 1 (b) ③ for information regarding exchange parameter settings (Usage availability settings and exchange address settings).
- (2) The remote node's range that can be exchanged by pairing open is either the remote node within Ethernet that QE71 is connected or the remote node connected by router relay function (Refer to Chapter 12).

Remarks

(1) Following is shown the open processing image when pairing is set.

<Example 1> Pairing between QE71s

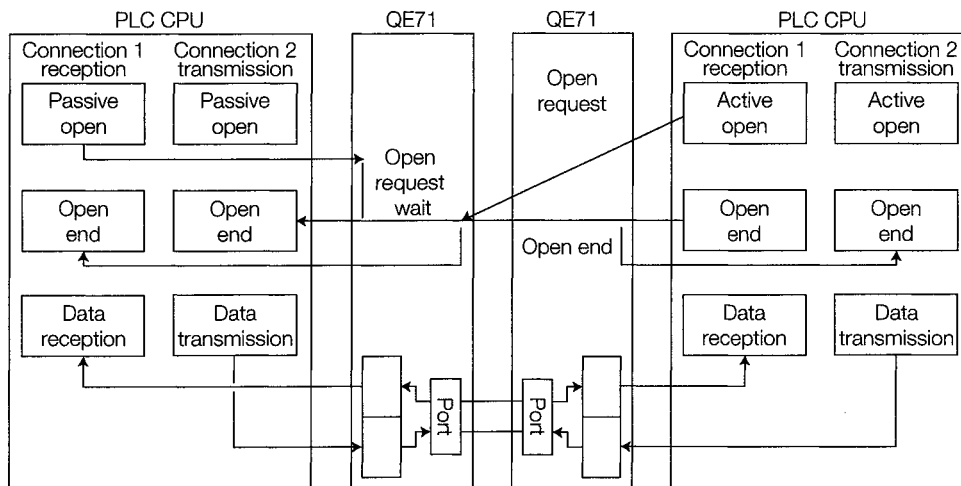

<Example 2> Connection between QE71 and partner node

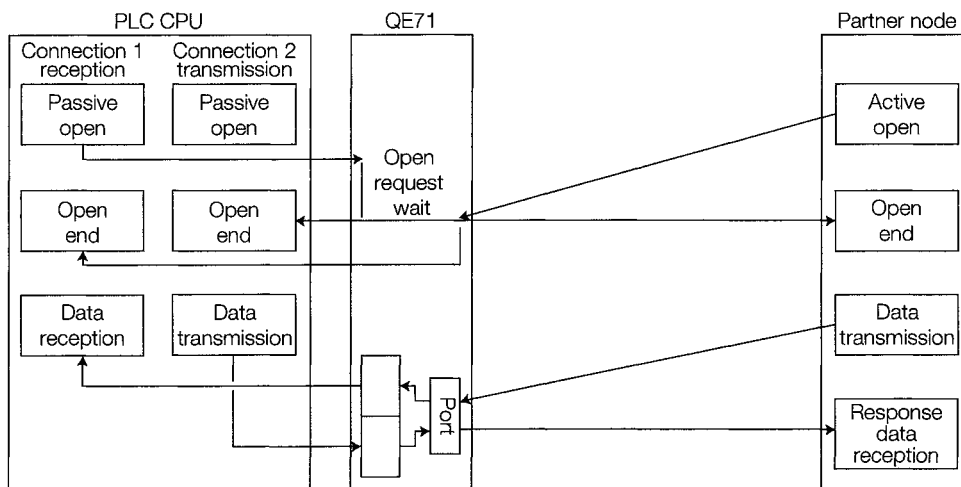

- (2) When conducting fixed buffer exchange using pairing open, use one port each for the QE71 and the partner remote node. The QE71 uses the reception data subheader to determine whether the reception data from the remote node is text or response. The remote node also uses the subheader to determine whether the received data is text or response.

(Example) For fixed buffer exchange (with procedure)

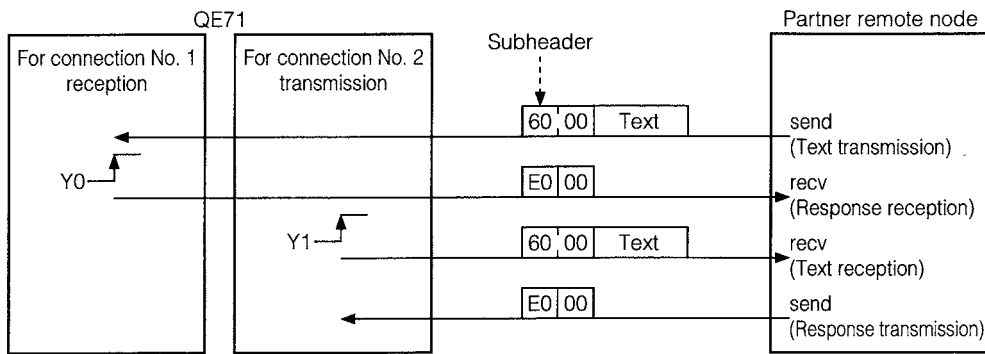

- (3) For more details on cases when the reception of Close/Abort (RST) has occurred from the partner remote node prior to the completion of the data communication performed immediately before, refer to Remarks in 2 of Item 5.5.3.

5.5.5 Example Program

This section explains an example sequence program used to do the connection open processing for the QE71 and a remote node.

(Example) The following is an example program.

- (1) The QE71 is installed in the main bases "0" slot.
- (2) Exchange parameters are shown in the table below.

Exchange parameter name (When does not opening pairing)		Connection No.1	Connection No.2
Usage availability setting	Fixed buffer usage availability Bit 0	0 : For transmission	1 : For reception
	Destination existence check Bit 1	0 : Not performed	1 : Performed
	Pairing open Bit 7	0 : Not performed	0 : Not performed
	Communication format Bit 8	0 : TCP	0 : TCP
	Fixed buffer exchange procedure existence Bit 9	0 : With procedure	0 : With procedure
	Open method Bit 14 Bit 15	10 : Unpassive	10 : Unpassive
Exchange address setting	QE71 port No.	500H	501H
	Remote node IP address	(Setting not required)	(Setting not required)
	Remote node port No.	(Setting not required)	(Setting not required)
	Remote node Ethernet address	(Default value)	(Default value)

Exchange parameter name (When opening pairing)		Connection No.1	Connection No.2
Usage availability setting	Fixed buffer usage availability Bit 0	1 : For reception	(Setting not required)
	Destination existence check Bit 1	1 : Performed	
	Pairing open Bit 7	1 : Performed	
	Communication format Bit 8	0 : TCP	
	Fixed buffer exchange procedure existence Bit 9	0 : With procedure	
	Open method Bit 14 Bit 15	10 : Unpassive	
Exchange address setting	QE71 port No.	500H	
	Remote node IP address	(Setting not required)	
	Remote node port No.	(Setting not required)	
	Remote node Ethernet address	(Default value)	

1 When does not opening pairing

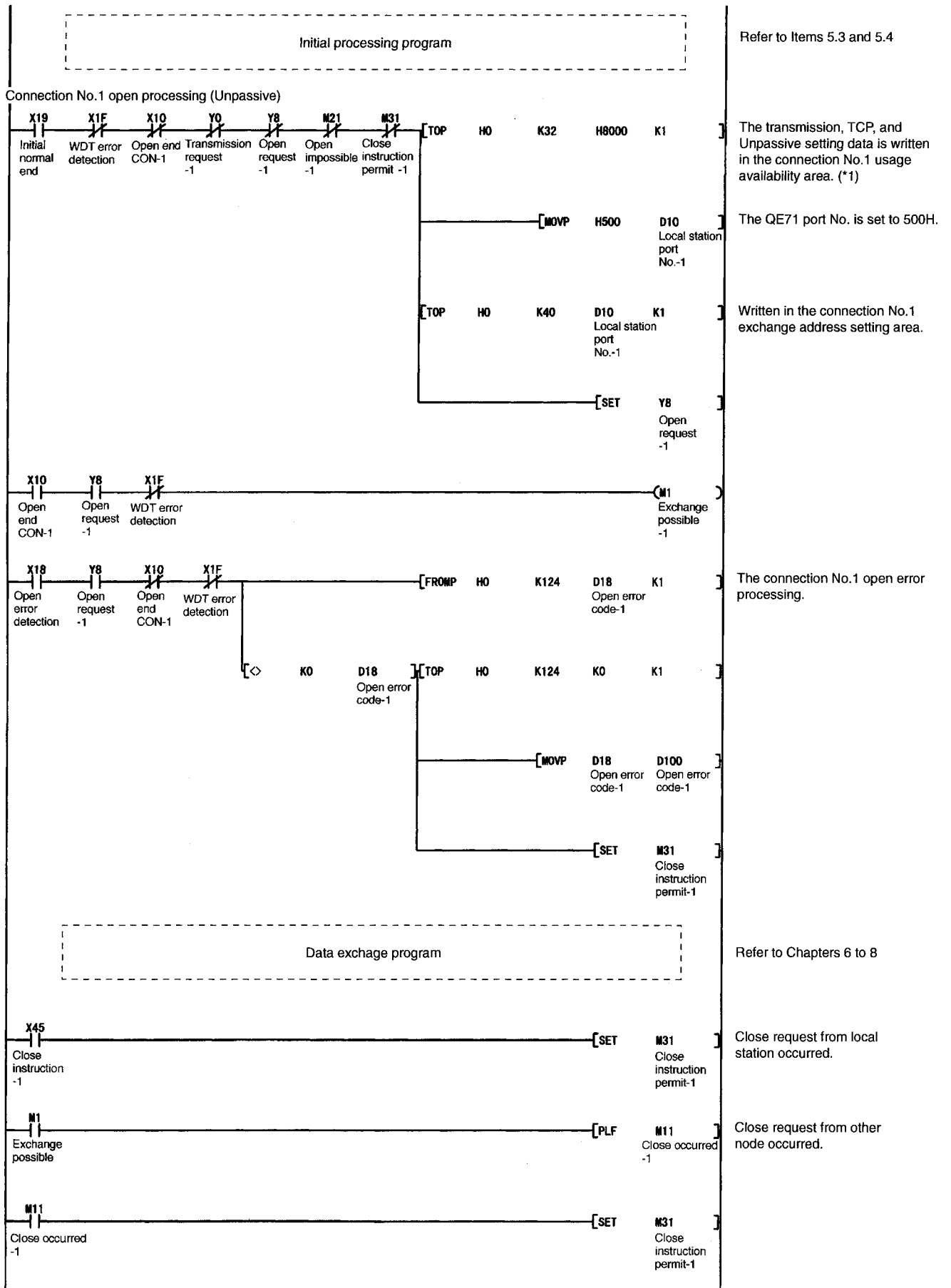

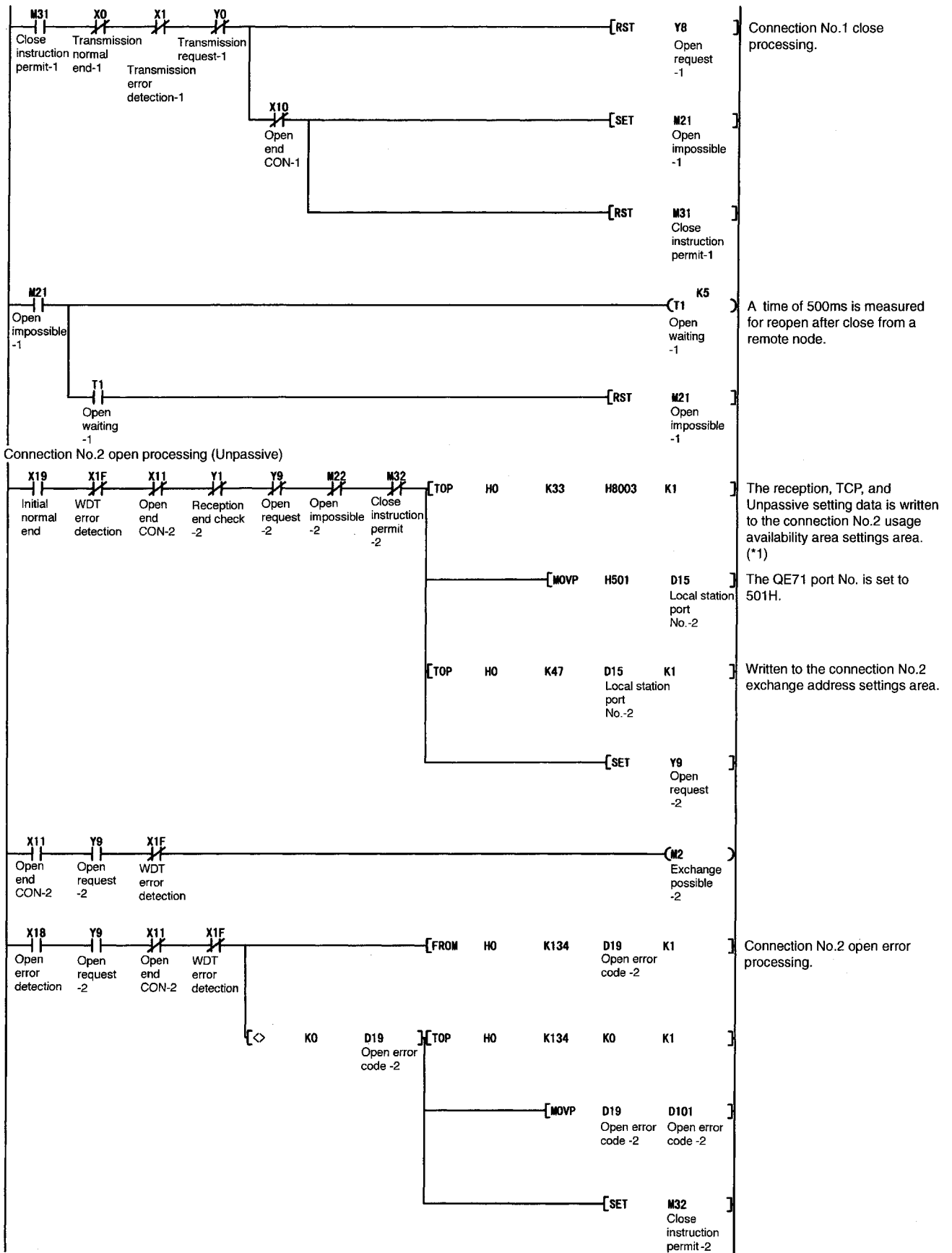

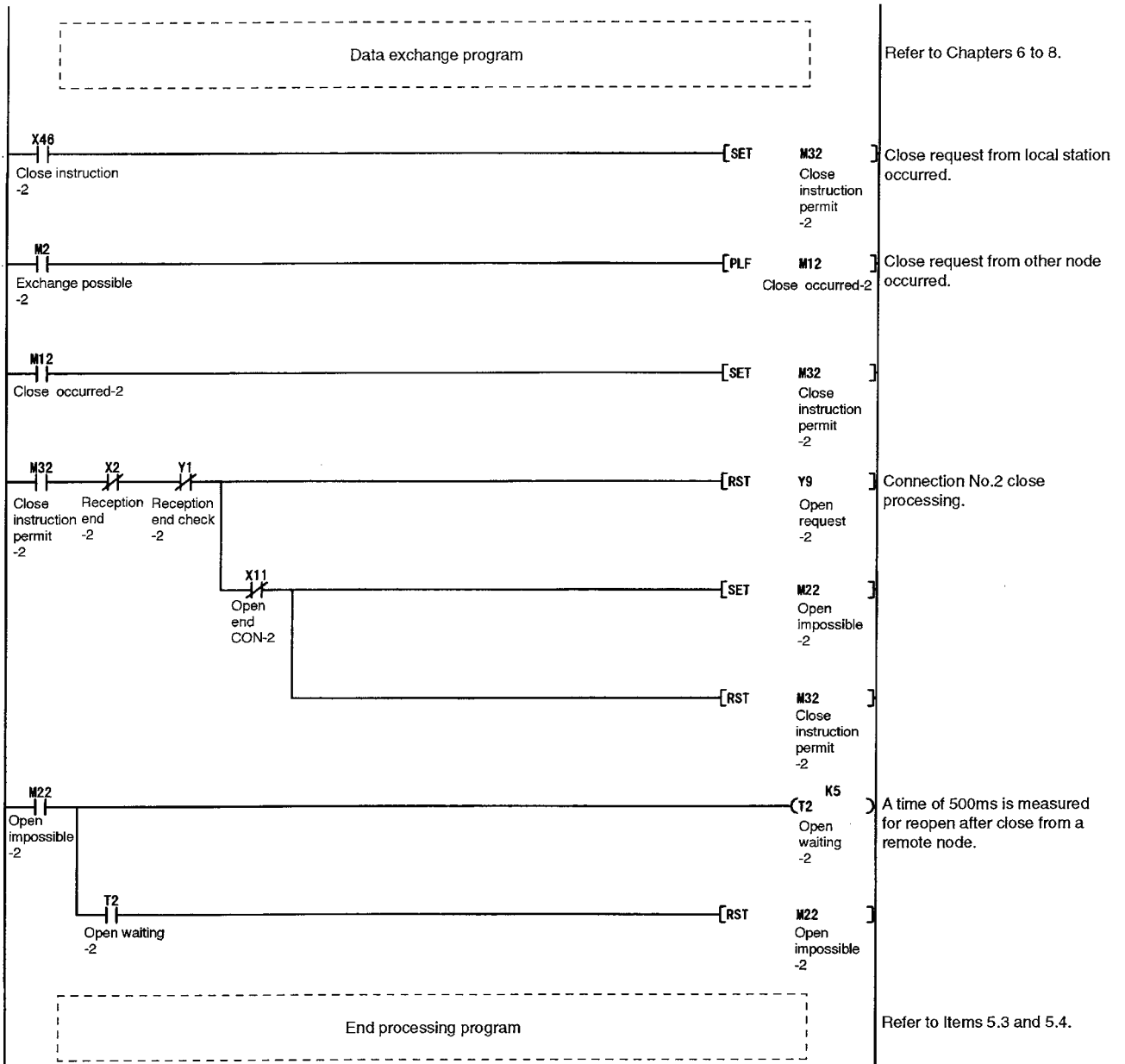

*1 The data exchange can be conducted with the setting of usage availability shown in the program.

	Fixed buffer exchange		Random access buffer exchange	Read/write data in the PLC CPU
	With procedure	Without procedure		
Connection No.1	Exchange enabled (Transmission only)	Exchange disabled	Exchange enabled	Exchange enabled
Connection No.2	Exchange enabled (Reception only)	Exchange disabled	Exchange enabled	Exchange enabled

Point

The close processing part of the program example shown in this section indicates only when close processing is performed while all the input signals from the QE71 for data exchange are off. For an example of a program when close processing is performed while all the input signals from the QE71 for data exchange are not off, see Appendix 7.2.

2 When opening pairing

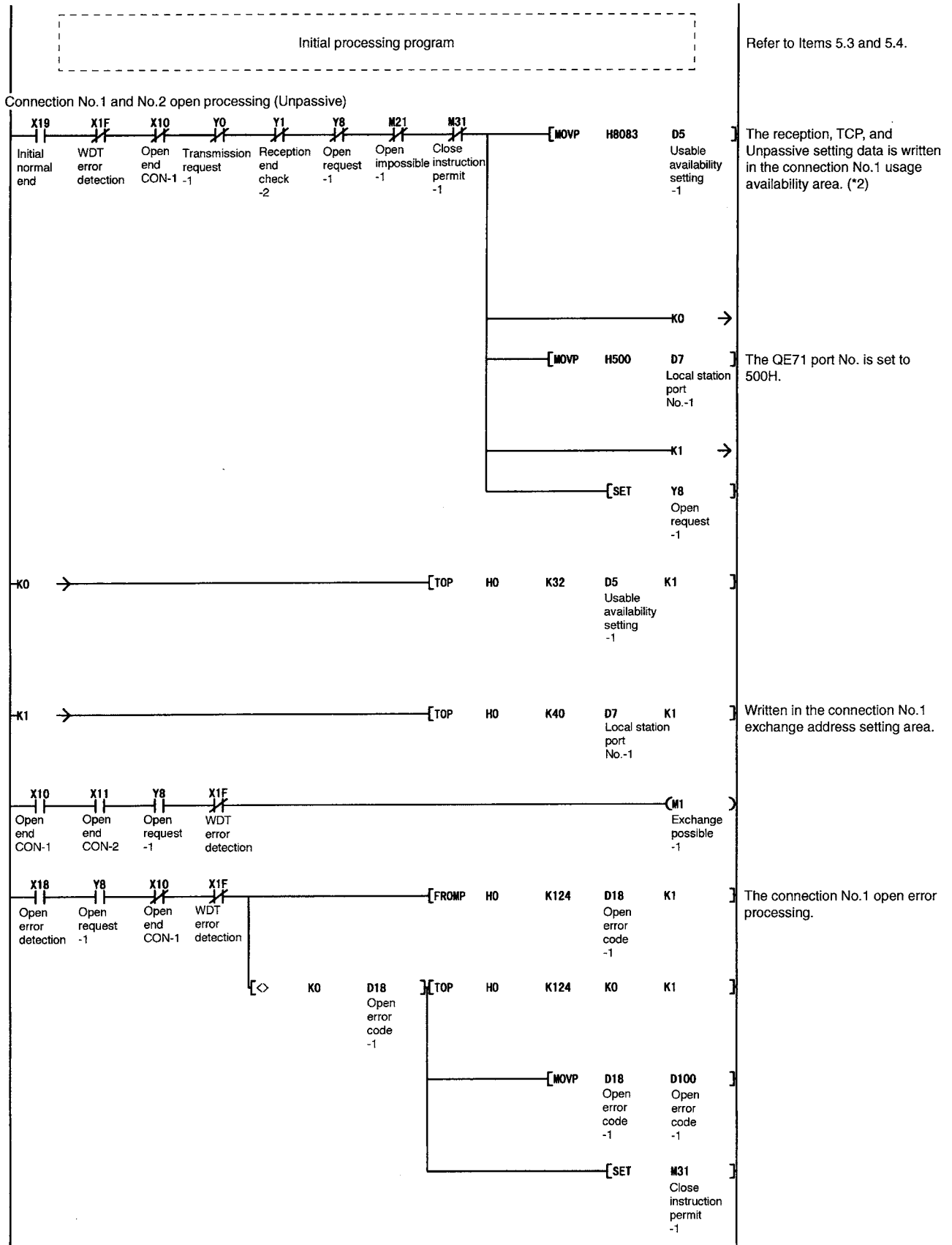

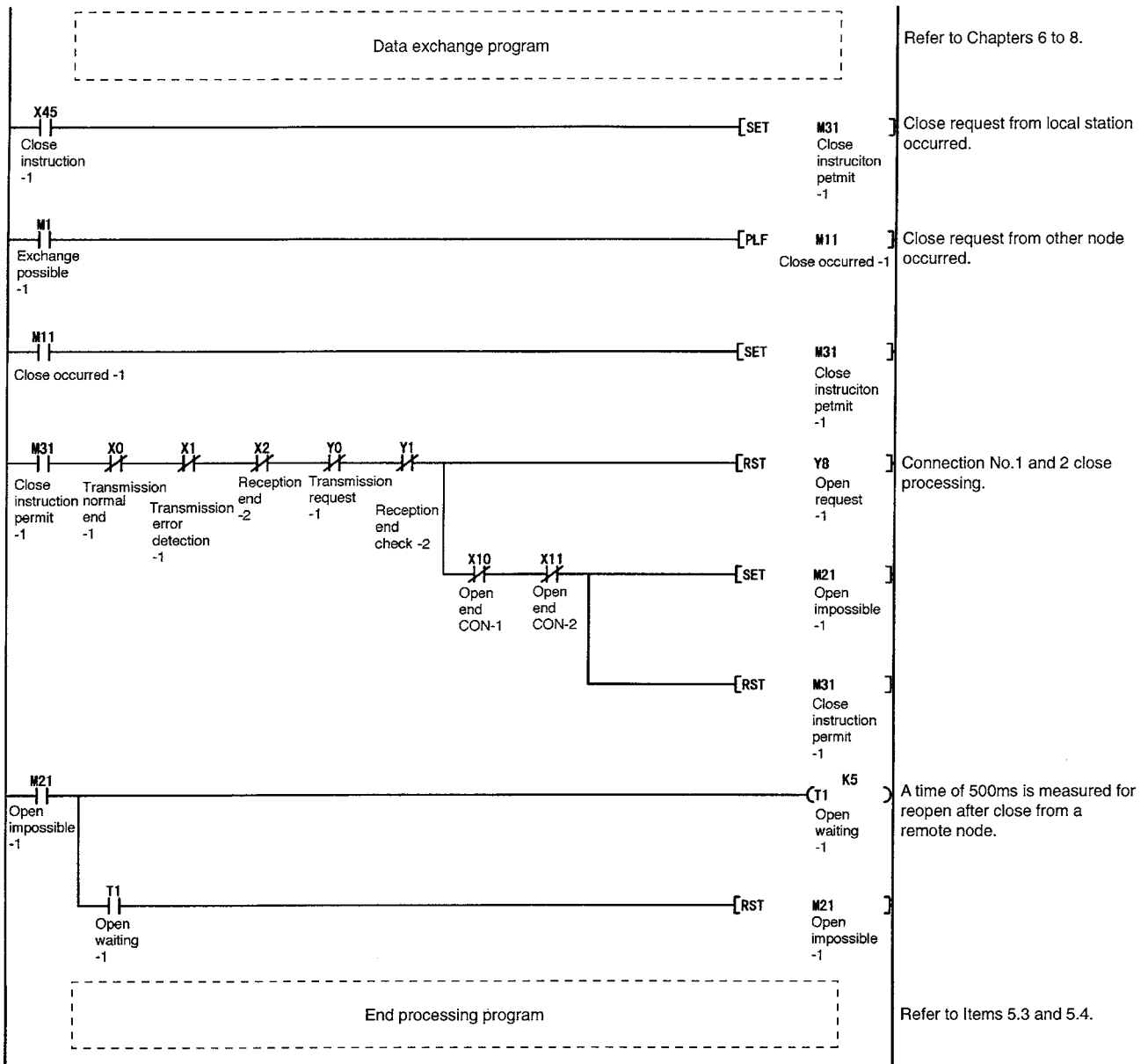

*2 The data exchange can be conducted with the setting of usage availability shown in the program.

	Fixed buffer exchange		Random access buffer exchange	Read/write data in the PLC CPU
	With procedure	Without procedure		
Connection No.1	Exchange enabled (Reception only)	Exchange disabled	Exchange enabled	Exchange enabled
Connection No.2	Exchange enabled (Transmission only)	Exchange disabled	Exchange enabled	Exchange enabled

5.6 Exchange State Storage Area

This section explains about the exchange state storage area where the initial processing state, open processing state, exchange state for each connection, and error log information are stored. Each processing result, exchange state for each connection, and error information can be checked by reading from this area.

5.6.1 Exchange State Storage Area

		Buffer memory		
(Address)		Exchange state storage area (119 words)		Default value
69H (105)	Initial error code	(1 word)	0H (0)
6A to 6BH (106 to 107)		Local station QE71's IP address	(2 words)	0H (0)
6C to 6EH (108 to 110)		Local station QE71's Ethernet address	(3 words)	0H (0)
6FH (111)	System area	(1 word)	—
70H (112)	EEPROM registration status	(1 word)	AAAH (2730)
71H (113)	Parameter usage status	(1 word)	0H (0)
72H (114)	EEPROM read results	(1 word)	0H (0)
73H (115)	EEPROM write results	(1 word)	0H (0)
74H (116)	Automatic open UDP port No.	(1 word)	0H (0)
75H (117)	System area	(1 word)	—
76H (118)	Network No. station No.	MELSECNET/10 relay exchange	0H (0)
77H (119)	Group No.	local station information (2 words)	0H (0)
78H (120)	Local station QE71's port No.	Information by connection (Connection No.1 10 words)	0H (0)
79 to 7AH (121 to 122)		Remote node IP address		0H (0)
7BH (123)	Remote node port No.		0H (0)
7CH (124)	Open error code		0H (0)
7DH (125)	Fixed buffer transmission/reception error code		0H (0)
7EH (126)	Connection end code/Error log		0H (0)
7FH (127)	Maximum value		0H (0)
80H (128)	Minimum value		0H (0)
81H (129)	Current value	0H (0)	
82 to 8BH (130 to 139)		Local station QE71's port No. to	Information by connection (For connection No.2)	(Same as above)
8C to 95H (140 to 149)		Local station QE71's port No. to	Information by connection (For connection No.3)	(Same as above)
96 to 9FH (150 to 159)		Local station QE71's port No. to	Information by connection (For connection No.4)	(Same as above)
A0 to A9H (160 to 169)		Local station QE71's port No. to	Information by connection (For connection No.5)	(Same as above)
AA to B3H (170 to 179)		Local station QE71's port No. to	Information by connection (For connection No.6)	(Same as above)
B4 to BDH (180 to 189)		Local station QE71's port No. to	Information by connection (For connection No.7)	(Same as above)
BE to C7H (190 to 199)		Local station QE71's port No. to	Information by connection (For connection No.8)	(Same as above)
C8H (200)	LED lighted status (1 word each)	Left side	0H (0)
C9H (201)		Right side	0H (0)
CAH (202)	Operating mode setting switch setting state	(1 word)	(Switch setting)
CBH (203)	Exchange condition setting switch setting state	(1 word)	(Switch setting)
CCH (204)	System area	(1 word)	—
CDH (205)	RECV command execution request	(1 word)	0H (0)
CEH (206)	System area	(1 word)	—
CF to DFH (207 to 223)		Data link command execution result by channel	(17 words)	0H (0)

* After processes end from initial processing the corresponding values are stored in order.

1 Initial error code (Default value = 0H) Address 69H (105)

- (a) Stores the error codes generated during initial processing execution.
- (b) Please refer to Chapter 17 for details regarding initial processing error codes.
- (c) Error codes are stored as binary values when the initial error detection signal (X1A) is on.
- (d) The error codes are cleared when the initial normal end signal is on, but the following process can also be used to clear them.
 - ① PLC CPU reset operation, or turning off the PLC power supply.
 - ② Using the sequence program to write (0) in the initial error code storage error

2 Local station QE71's IP address (Default value = 0H) Address 6AH to 6BH....(106 to 107)

- (a) Stores the QE71's IP address set during the initial processing execution.
- (b) The QE71's IP address is stored as a binary value.
 Example: The data storage condition when the IP address is A20009C0H (162.0.9.192) is shown below.

Address	Buffer memory
6AH(106)	09C0H
6BH(107)	A200H

3 Local station QE71's Ethernet address (Default value = 0H) Address 6CH to 6EH....(108 to 110)

- (a) After initial processing, the QE71's physical address is read from the ROM and stored. The Ethernet's physical address cannot be changed.
- (b) The QE71's Ethernet address is stored from the newest address in the L to H order.

4 EEPROM registration status (Default value = AAH) Address 70H (112)

- (a) Stores the setting values (parameters) registration state in the EEPROM built into the QE71.

b15	b14	b13	b12	b11	b10	b9	b8	b7	b6	b5	b4	b3	b2	b1	b0
					⑥	⑤	④	③	②	①					

- ① Initial processing parameters
 - ② Exchange parameters
 - ③ Router relay parameters (Including subnet mask fields.)
 - ④ Station No. <-> IP information parameters
 - ⑤ FTP parameters
 - ⑥ Exchange instruction parameters during STOP
- (b) The parameters registered in the EEPROM stored in the corresponding buffer memory as default values when the QE71 is booted up.
 - (c) The registration state is stored as the following values (the appropriate 2 bit portion).
 - 00 : No parameter registration
 - 01 : Parameter registration (registration parameters are in error)
 - 10 : Parameter registration (registered parameters are normal)

5 Parameter usage status (Default value = 0H)..... Address 71H (113)

(a) Stores the read state for each parameter when the setting values (parameters) registered in the EEPROM are read into the buffer memory by the following functions and operations.

- Read by the system when exchange condition setting switch (SW3: automatic start up mode setting) is turned on to boot up QE71.
- Read by the user using the functions described in Item 4.9.

b15	b14	b13	b12	b11	b10	b9	b8	b7	b6	b5	b4	b3	b2	b1	b0
0				⑥	⑤	④	③	②	①						

- ① Initial processing parameters
- ② Exchange parameters
- ③ Router relay parameters (Including subnet mask fields)
- ④ Station No. <-> IP information parameters
- ⑤ FTP parameters
- ⑥ Exchange instruction parameters during STOP

(b) The read state for the parameters is stored as the following values (corresponding 2 bit portion).

- 00 : No read/No parameter registration
- 01 : Read (read values are not set because of error end)
- 10 : Read (normal end)

6 EEPROM read results (Default value = 0H) Address 72H (114)

(a) Stores the read results read when the registered values (setting values) are read from the EEPROM during start up under automatic start up mode or when the EEPROM read request signal (Y10) is turned on.

(b) The parameter read results are stored as binary values.

- 0 : Normal end
- Other than 0: Error end (refer to Chapter 17 for explanation of error code items.)

(c) When an error end occurs, please check the parameter read states using the parameter usage states described in **5** above.

7 EEPROM write results (Default value = 0H) Address 73H (115)

(a) Stores the results when the functions described in Item 4.9 are used by the user to write and register the buffer memory setting values to the EEPROM.

(b) The parameter write results are stored as binary values.

- 0 : Normal end
- Other than 0: Error end (refer to Chapter 17 for explanation of error code items.)

8 Automatic open UDP port No. (Default value = 1388H)..... Address 74H (116)

(a) Stores the automatically connected communication line port No. after QE71 initial processing execution is over.

(b) The port No. is the No. set by the user as an initial processing parameter (default value is 5000).

(c) Refer to Item 5.7 for information regarding data exchange that uses automatic open UDP port Nos.

9 Local station information for MELSECNET/10 relay exchange (Default value = 0H)Addresses 76H to 77H (118 to 119)

(a) The network number, the group number and the station number that are set by the Ethernet parameters for the use of MELSECNET/10 relay exchange function are stored at these addresses.

The values stored are the values set on the GPP screen at Item 15.3.2.

(b) The network number, the group number and the station number are stored as follows.

(Address)	b15	to	b8	b7	to	b0
76H(118)	Network No.			Station No.		
77H(119)	0			Group No.		

10 Information by connections: Local station QE71's port No. (Default value = 0H) Address 78H....(120...)

- (a) Stores the port No. when the corresponding communication line was connected by open processing.
- (b) The storage values are not set during the closed state.

11 Information by connection: Remote node IP address (Default value = 0H) Address 79H to 7AH....(121 to 122...)

- (a) Stores the partner remote node's IP address for when the corresponding communication line was connected using open processing.
(Example) The following is the data that is stored when the IP address is "A20009C0H."

Address	Buffer memory
79H(121)	09C0H
7AH(122)	A200H

- (b) The stored values are not set that are in the close state.

12 Information by connections: Remote node port No. (Default value = 0H) Address 7BH....(123...)

- (a) Stores the partner remote node port No. for the communication line connected by open processing.
- (b) The stored value is not set in the closed state.

13 Information by connections: Open error code (Default value = 0H) Address 7CH....(124...)

- (a) Stores the open processing results of the corresponding communication line.
- (b) The open processing results are stored as binary values.
0: Normal end
Other than 0: Error end (refer to Chapter 17 for information regarding error code items, cleared when reopened next time.)
- (c) Error code is cleared by performing the following operations.
 - ① When re-open the connection in which the open error occurred.
(When open request signal is turned ON from OFF)
 - ② When reset the PLC CPU operation or the PLC power supply is turned OFF.

14 Information by connections: Fixed buffer transmission/reception error code (Default value = 0H) Address 7DH....(125...)

- (a) Stores the error code (refer to Chapter 17 for details regarding error code items) generated when the error detection signal (X1, etc.) is turned on by the data transmission/reception with the remote node during fixed buffer exchange on the corresponding communication line.
- (b) The transmission error codes are included under the following conditions.
 - When the data transmission is normal end.
 - When the transmission request signal/reception end check signal are turned off.

- 15** Information by connections: connection end code/Error log (Default value = 0H).
 Address 7EH....(126...)
- (a) The error codes that are returned as a response from the remote node during fixed buffer exchange on the corresponding communication line are stored as binary values.
 - (b) The action to be taken by the end code in the response is conducted in accordance with the arrangements with the remote node.

- 16** Information by connections : Fixed buffer exchange time (Each default value = 0H)
 7FH to 81H....(127 to 129...)
- (a) Each of the fixed buffer exchange processing times (maximum value, minimum value, current value) are stored.
 - ① Fixed buffer transmission processing time
 The time from when the transmission request signal turns on to when the QE71 conducts a transmission normal end. When abnormal transmission occurs, process time is not stored.
 - ② Fixed buffer reception processing time
 The time from when the reception end signal turns on to when the QE71 ends in response to the response return processing from the remote node.
 - (b) The processing time is stored as a binary value in 10ms units.
 - (c) Each exchange time is changed to "0," when the subject communication line's open request signal (Y8 to YF) is changed from off to on.

- 17** LED lighted status (Default value = 0H) Address C8H to C9H (200 to 201)
- (a) Stores the lighted state for the LED on the front of the QE71 main module.
 - (b) The lighted state and stored value (corresponding 1 bit portion) are as shown below, and the LED for the corresponding bit is as follows.

Refer to Item 4.4 for a description of when the LED is turned on and turned off.

(Stored values)

1 : Turned on 0 : Turned off

(The main module left side LED for the corresponding bit of the address C8H(200))

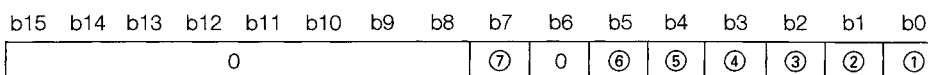

	LED name	Display contents
①	SW. ERR.	Installed CPU error etc.
②	RDY	Exchange ready end
③	BSY	Exchange processing executing
④	COM. ERR.	Exchange error detection
⑤	TRAN. S	Data link command request executing (*1)
⑥	TRAN. R	Data link command RECV waiting (*1)
⑦	FTP	FTP server functions operating (*1)

*1 There is no corresponding LED for the QE71, but the corresponding bit is turned on by the factor shown in the table.

(Main module right side LED for the corresponding bit of address C9H (201))

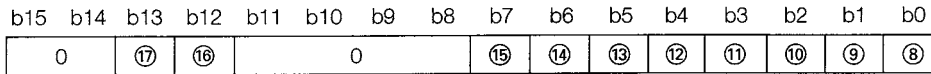

LED	LED name	Display contents
⑧	BUF 1	Communication line connection state
⑨	BUF 2	
⑩	BUF 3	
⑪	BUF 4	
⑫	BUF 5	
⑬	BUF 6	
⑭	BUF 7	
⑮	BUF 8	
⑯	TEST	Self-diagnosis executing
⑰	TEST ERR.	Self-diagnosis error end

18 Operation mode setting switch setting state (Default value = switch setting value) Address CAH (202)

- (a) Stores the setting contents of the operation mode setting switch on the front of the main module when the QE71 is started up.
- (b) The setting switch setting state stores the switch setting values (0 to 5) as binary values.

19 Exchange conditions setting switch setting state (Default value = switch setting value) Address CBH (203)

- (a) The settings of the QE71's exchange condition setting switch on the main module are stored when the QE71 is started up.
- (b) The setting switch setting state and stored values (corresponding 1 bit portion) are as follows, and exchange condition setting switch for the corresponding bit is shown below. Refer to Item 4.3.2 for information regarding the contents during ON and OFF.

(Stored values)

1 : ON 0 : OFF

(The main module exchange condition setting switches for the corresponding bits of address CBH (203))

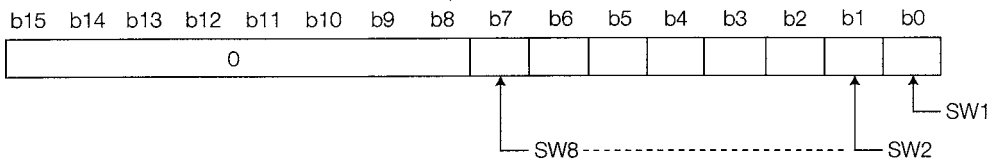

20 RECV command execution request (Default value = 0H)Address CDH (205)

- (a) Indicates whether data transmitted by the SEND command from the QnACPU of the QE71 installed station are stored in the specified channel in the local station QE71 (by SEND command).
- (b) The bits corresponding to the buffer memory channel numbers indicate whether data are stored or not as follows:

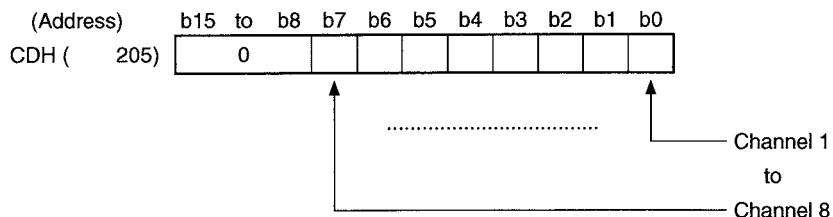

0: Data not stored
1: Data stored

- (c) Data are stored in channels where the bit indications are on (1).
Read the data stored in corresponding channels with the RECV command.

21 Data link command execution result by channel (Default value = 0H)Addresses CFH to DFH (207 to 223)

- (a) Execution result of data link command at local station QnACPU for the PLC CPU at remote stations via QE71 is stored.
- (b) Execution result of data link command is stored in each channel used in binary value.
 - The result for SEND, RECV, READ, WRITE, or REQ is stored in the corresponding area for the channel specified in the control data of each command.
 - The result for ZNRD is stored in the address CFH (207), and the result for ZNWR is stored in D1H (209).

Addresses	Contents	Storage area for execution result for each data link command						
		SEND	RECV	READ	WRITE	ZNRD	ZNWR	REQ
CFH (207)	Channel 1 execution result	○	○	○	○	○	-	○
D1H (209)	Channel 2 execution result	○	○	○	○	-	○	○
D3H (211)	Channel 3 execution result	○	○	○	○	-	-	○
D5H (213)	Channel 4 execution result	○	○	○	○	-	-	○
D7H (215)	Channel 5 execution result	○	○	○	○	-	-	○
D9H (217)	Channel 6 execution result	○	○	○	○	-	-	○
DBH (219)	Channel 7 execution result	○	○	○	○	-	-	○
DDH (221)	Channel 8 execution result	○	○	○	○	-	-	○

○: Stored -: Not stored

* Within the range of buffer memory addresses CFH to DFH, addresses not indicated above belong to the system area.

- (c) The contents of stored values are as follows:
 The stored values are used for monitoring the results of data link commands with the GPP.
 0 : Completed normally
 Other than 0 : Completed error (Refer to the section which describes "error code" in Chapter 17.)

5.6.2 Error Log Area

This is the area that stores the following two errors.

- ① Those errors for which the occurrence origin cannot be checked
 IP level error and reception data check sum error (TCP, UDP, IP check sum error).
- ② Errors that occur during random access buffer exchange and reading and writing data in the PLC CPU

The values stored in these areas are cleared when the QE71 installed station power is turned on or when reset is performed (not cleared during initial processing). Reading from this area is not normally required. Read when necessary for maintenance.

Buffer memory

(Address)	Error log area (288 words)		Default values	
E0 to E2H (224 to 226)	System area (3 words)		—	
E3H (227)	Number of errors generated (1 word)		0H (0)	
E4H (228)	Error log write pointers (1 word)		0H (0)	
E5H (229)	Error code · End code	Error log block area (144 words)	0H (0)	
E6H (230)	Subheader		0H (0)	
E7H (231)	Command code		0H (0)	
E8H (232)	Connection No.		0H (0)	
E9H (233)	Local station QE71 port No.		0H (0)	
EA to EBH (234 to 235)	Remote node IP address		0H (0)	
ECH (236)	Remote node port No.		0H (0)	
EDH (237)	System area		—	
EE to F6H (238 to 246)	Error code · End code to (9 words)		Error log block 2	(Same as above)
E7 to FFH (247 to 255)	Error code · End code to (9 words)		Error log block 3	(Same as above)
100 to 108H (256 to 264)	Error code · End code to (9 words)		Error log block 4	(Same as above)
109 to 111H (265 to 273)	Error code · End code to (9 words)		Error log block 5	(Same as above)
112 to 11AH (274 to 282)	Error code · End code to (9 words)		Error log block 6	(Same as above)
11B to 123H (283 to 291)	Error code · End code to (9 words)		Error log block 7	(Same as above)
124 to 12CH (292 to 300)	Error code · End code to (9 words)	Error log block 8	(Same as above)	
12D to 135H (301 to 309)	Error code · End code to (9 words)	Error log block 9	(Same as above)	
136 to 13EH (310 to 318)	Error code · End code to (9 words)	Error log block 10	(Same as above)	
13F to 147H (319 to 327)	Error code · End code to (9 words)	Error log block 11	(Same as above)	
148 to 150H (328 to 336)	Error code · End code to (9 words)	Error log block 12	(Same as above)	
151 to 159H (337 to 345)	Error code · End code to (9 words)	Error log block 13	(Same as above)	
15A to 162H (346 to 354)	Error code · End code to (9 words)	Error log block 14	(Same as above)	

(to the next page)

(continued from the previous page)

Buffer memory

(Address)	Error log area (288 words)		Default values
163 to 16BH (355 to 363)	Error code · End code to	Error log block 15 (9 words)	(Same as above)
16C to 174H (364 to 372)	Error code · End code to	Error log block 16 (9 words)	(Same as above)
175 to 177H (373 to 375)	System area	(3 words)	—
178 to 179H (376 to 377)	Total number of IP packet received	(2 words)	0H (0)
17A to 17BH (378 to 379)	Total number of received IP packets discarded due to check sum errors	(2 words)	0H (0)
17C to 17DH (380 to 381)	Total number of transmitted IP packets	(2 words)	0H (0)
17E to 17FH (382 to 383)	System area	(2 words)	—
180 to 181H (384 to 385)	Number of received ARP packets	(2 words)	0H (0)
182 to 183H (386 to 387)	Number of responses to ARP packets	(2 words)	0H (0)
184 to 185H (388 to 389)	Number of received IP packets that are not broadcasted to local station	(2 words)	0H (0)
186 to 187H (390 to 391)	System area	(2 words)	—
188 to 189H (392 to 393)	Number of transmitted ARP packets	(2 words)	0H (0)
18A to 18BH (394 to 395)	Number of transmitted broadcast packets	(2 words)	0H (0)
18C to 197H (396 to 407)	System area	(12 words)	—
198 to 199H (408 to 409)	Total number of received ICMP packets	(2 words)	0H (0)
19A to 19BH (410 to 411)	Total number of received ICMP packets discarded due to check sum errors	(2 words)	0H (0)
19C to 19DH (412 to 413)	Total number of transmitted ICMP packets	(2 words)	0H (0)
19E to 19FH (414 to 415)	Total number of received ICMP echo request packets	(2 words)	0H (0)
1A0 to 1A1H (416 to 417)	Total number of transmitted ICMP echo reply packets	(2 words)	0H (0)
1A2 to 1A3H (418 to 419)	Total number of transmitted ICMP echo request packets	(2 words)	0H (0)
1A4 to 1A5H (420 to 421)	Total number of received ICMP echo reply packets	(2 words)	0H (0)
1A6 to 1B7H (422 to 439)	System area	(18 words)	—
1B8 to 1B9H (440 to 441)	Total number of received TCP packets	(2 words)	0H (0)
1BA to 1BBH (442 to 443)	Total number of received TCP packets discarded due to check sum errors	(2 words)	0H (0)
1BC to 1BDH (444 to 445)	Total number of transmitted TCP packets	(2 words)	0H (0)
1BE to 1BFH (446 to 447)	Number of ZERO-Window time-outs	(2 words)	0H (0)
1C0 to 1D7H (448 to 471)	System area	(24 words)	—
1D8 to 1D9H (472 to 473)	Total number of received UDP packets	(2 words)	0H (0)
1DA to 1DBH (474 to 475)	Total number of received UDP packets discarded due to check sum errors	(2 words)	0H (0)
1DC to 1DDH (476 to 477)	Total number of transmitted UDP packets	(2 words)	0H (0)
1DE to 1DFH (478 to 479)	Number of times received UDP packets discarded due to incorrect destination	(2 words)	0H (0)
1E0 to 1FFH (480 to 511)	System area	(32 words)	—

Status for each protocol
(136 Words)

- 1** **Number of errors generated (Default value = 0H) Address E3H (227)**
- (a) Stores the number of errors registered in the error log block area.
 - (b) When more than 65536 errors occur, becomes FFFFH (65535).
 - (c) The processing of storing the error information into the following areas is continued even if the counting of the error occurrence count storage area is stopped (FFFFH).
 - Error log write pointer storage area
 - Error log block

- 2** **Error log write pointer (Default value = 0H) Address E4H (228)**
- (a) Stores the error log block No. of the most recently registered error log.
 - (b) Shows that the most recent error log has been registered in the error log block 1 area when the pointer value is "1," or error log block 16 when the pointer value is "16." The error log is not registered when the pointer value is "0."
 - (c) When the number of errors that has occurred exceeds 17, error log registration is begun again with the error log block 1 area.

- 3** **Error log block : Error code · End code (Default value = 0H) Address E5H....(229...)**
- (a) The error log block area is comprised of 16 error log blocks that contain the same data.
 - (b) The codes that show the contents of the errors are stored in the error log and end code areas. (Refer to Chapter 17.)

- 4** **Error log block : Subheader (Default value = 0H) Address E6H....(230...)**
- (a) The subheader code of the message for which an error occurred is stored in bits 0 through 7 of the corresponding area. ("0" is stored in bits 8 through 15.)
 - (b) Errors under the TCP and UDP level are stored as "0."

- 5** **Error log block : Command code (Default value = 0H) Address E7H....(231...)**
- (a) Stores the command code of the message in which an error occurred, or each low-level byte value of the request type and subrequest type of the instruction for the data link.

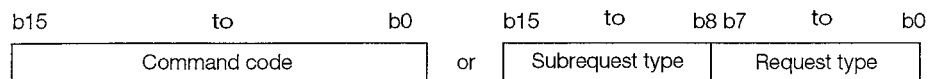

- (b) "0" is stored in the following cases.
 - Message with no command code
 - Errors that are under the TCP and UDP level (because the command is not understood)

- 6** **Error log block : Connection No. (Default value = 0H) Address E8H....(232...)**
- (a) The connection No. in which an error occurred is stored in bits 0 through 7 of the corresponding area. ("0" is stored in bits 8 through 15.)
 - (b) Errors under the TCP and UDP level are stored as "0."

- 7** **Error log block : Local station QE71 port No. (Default value = 0H)**
..... Address E9H....(233...)
- (a) The local station QE71's port No. in which an error occurred is stored.
(b) Errors under the TCP and UDP level are stored as "0."
- 8** **Error log block : Remote node IP address (Default value = 0H)**
..... Address EAH to EBH....(234 to 235...)
- (a) The partner remote node's IP address in which an error occurred is stored.
(b) "0" is stored in the following cases.
- An error under the IP level
 - When there is an error response when a relay is received from the PLC CPU
- 9** **Error log block : Remote node port No. (Default value = 0H)**
..... Address ECH (236...)
- (a) The partner remote node's port No. in which an error occurred is stored.
(b) Errors under the TCP and UDP level are stored as "0."
- 10** **Status for each protocol Address 178H to 1FFH (376 to 511)**
- (a) Stores the total number of events for each protocol. (Count value from QE71)
(b) When two words are exceeded, the count stops at FFFFFFFFH (4294967295).

5.7 Automatic Open UDP Port

Normally when exchanging with a remote node, when data exchange is complete the communication line connection with the exchange partner in which data exchange was begun must be terminated following the arrangement between the nodes.

The automatic open UDP port is a UDP/IP port that automatically opens and closes as shown below.

This port changes to the exchange possible state after initial processing and makes it possible to exchange without a sequence program, regardless of the open state of connections Nos. 1 to 8 .

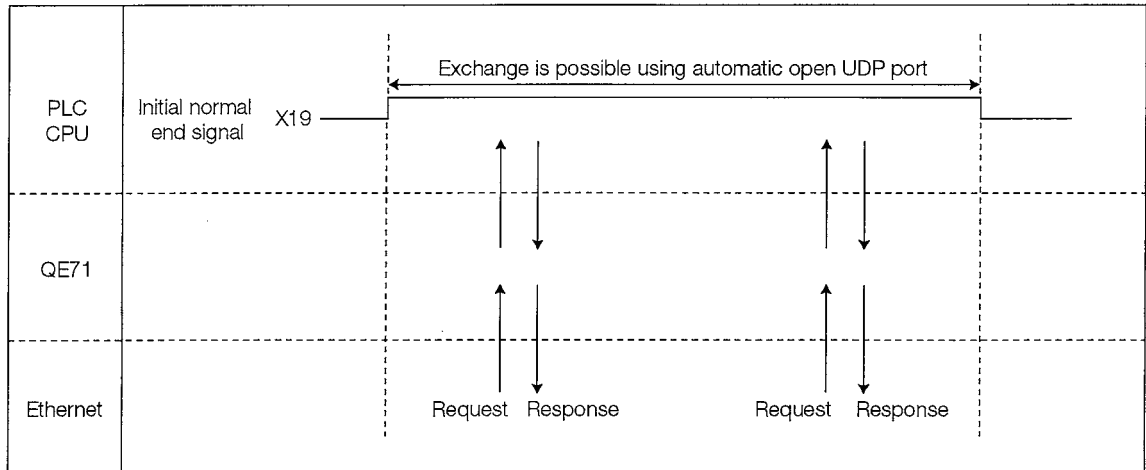

1 Automatic open UDP port open and close timing

① Open

After initial processing, automatic open is conducted and the communication line connected following the setting values (parameters) registered in the QE71's EEPROM by the user. (UDP/IP open end state)

② Close

Automatically closes after end processing.

2 Functions that can exchange data with the automatic open UDP port

① Exchange from remote nodes

- Read/write data in the PLC CPU by the QE71 command (Port numbers are specified by user, default value is 5000.) Exchange is possible only with the binary code.

② Exchange from QE71 installed stations.

- Communication by data link instruction. (Use QE71's OS port numbers.)

Point

- (1) When the initial processing is completed normally, the QE71 is able to exchange using the automatic open UDP port number, and is ready for an exchange request to the local station QE71. (Automatic open)
- (2) If requesting to itself, the QE71 accepts any request, and performs the processing.
- (3) During receiving requests from remote node or local station QnACPU, the applicable port number is occupied until the processing is completed. In this period, process of exchange is on hold, even subsequent exchange are requested.
- (4) Automatic open UDP ports are also used for exchange between QE71's by the MELSECNET/10 relay exchange function.
- (5) When the port number of the automatic open UDP port is changed, initial processing must be performed again.

3 Accessible range

Varies depending upon data exchange function.

Data exchange function	Accessible range	Detailed explanation
Read/write data in the PLC CPU	① QnACPU at QE71 installed stations ② PLC CPUs in data link system/network system which includes the QE71 installed stations	—
Data link command	① PLC CPUs on the Ethernet connected to QE71 ② PLC CPUs on the Ethernet connected via router ③ PLC CPUs in data link system/network system which includes the QE71 installed stations, etc.	Item 15.2

4 Maximum data volume at a time

Varies depending upon data exchange function.

Data exchange function	Maximum data volume at a time	Detailed explanation
Read/write data in the PLC CPU	Data volume that can be specified with the QE71 commands	Chapter 10
Data link command	Data volume that can be specified with the data link commands	Item 14.4

5 Setting up data into buffer memory

Set up with the data exchange function to be used, before performing initial processing.

Data exchange function	Setting data	Setting area	Detailed explanation
Read/write data in the PLC CPU	① Automatic open UDP port No.	Initial processing parameter setting area	Item 4.8 Item 5.2.2
Data link command	① Ethernet parameter	(Set up with GPP)	Item 4.8 Item 15.3
	② Conversion format	Initial processing parameters setting area	
	③ Station No. <-> IP information parameter	Station No. <-> IP information parameter	
	:	:	

5.8 Precautions for Programming

This section describes the precautions for programming to perform data exchange between the PLC CPU and remote nodes using the QE71.

1

Countermeasures for data exchange problems during communication

Perform the following processing if the connection being used is closed due to a data exchange problem after open processing has completed normally.

- ① Turn off the transmission request signal/reception completion confirmation signal (Y0 to Y7).
- ② After the following input signals corresponding to the above signals are set to off, perform open processing again.
 - Transmission normal completion signal, reception completion signal (X0, X2...)
 - Transmission error detection signal, reception error detection signal (X1, X3...)

As for the timing to reopen the connection being used, see Item 5.5.3.

Program examples are shown in Item 5.5.5 as well as Item 7.2 of Appendix.

Remarks

When the existence check function of the QE71 is used (see Remark at the end of Item 5.5.3)

- If communication is disabled due to the occurrence of a sudden problem (down, etc.) on the remote node side, the QE71 will close (disconnect the line) the applicable connection if it detects an error using the existence check function.

2

Data exchange using a single connection

In order to prevent complications with application programs, it is recommended to open a connection (port) for each exchange function, and then perform data exchange.

(Example) To perform transmission/reception of fixed buffer data exchange and read/write exchange of data in the PLC CPU with the PLC side, open the following connections for data exchange, and then exchange data.

- For transmission of fixed buffer data exchange
- For reception of fixed buffer data exchange
- For read/write exchange of data in the PLC CPU

3

Capacity of data to be sent/received

To use the data exchange function using fixed buffer (with procedure) and data exchange function using random access buffer of the QE71, specify the *idata length* in the application data section of the message to be sent from a remote node to the QE71 using the actual data size of the text section.

If the data length is not correct, a response of abnormal completion will be returned.

4

Code for exchange data

Specify either ASCII code or binary code according to the setting value of the QE71's exchange condition setting switch (SW2: data code setting) in order to perform data exchange.

When SW2 is off: Data is exchanged using binary code

When SW2 is on: Data is exchanged using ASCII code

Referring to the reference section of the function to be used, check the arrangement of data for exchange.

5**Precautions for creating sequence programs for the QE71**

- (a) Be sure to follow the procedure below when performing various processing such as initial/open/data transmission and reception.
- ① Load the data (such as exchange conditions) for the applicable processing into the buffer memory.
 - ② Change the request signal (output (Y)) for the applicable processing from off to on.
 - ③ Check whether the normal completion signal (input (X)) for the applicable processing has changed from off to on.

* In the case of abnormal completion, read the error information stored in the buffer memory, change the request signal (output (Y)) of the applicable processing from on to off, and then check whether the abnormal completion signal (input (X)) for the applicable processing has changed from on to off.

After error processing completes, repeat from ① again.
 - ④ Change the request signal (output (Y)) for the applicable processing from on to off.
 - ⑤ Check whether the normal completion signal (input (X)) for the applicable processing has changed from on to off.
- (b) When performing TCP/IP communication, if the open processing of a connection from a remote node completes normally, but the same connection must be closed immediately, perform close processing after the open normal completion signal (X10 to X17) to the PLC CPU stays on for at least one scan time.

* This is necessary so that the PLC CPU can recognize the normal completion of open processing.
- (c) When performing TCP/IP communication, be sure to follow the procedure below to perform reopen processing on the QE71 side when close processing is performed from the remote node side after open processing has completed normally. (See Item 5.5.3 2.)
- ① Close from a remote node (open normal completion signal of the QE71 changes from on to off)
 - ② Close processing on the QE71 side (open request signal changes from on to off)
 - ③ Minimum 500 ms wait (wait time for the QE71)

* If close processing is performed from the QE71 side, it is not necessary to set up the wait time.
 - ④ Open processing on both the QE71 and remote node sides (QE71 side: Open request signal changes from off to on)
- (d) The detection of an open error for the eight connections of the QE71 is notified to the PLC CPU side with a single open error detection signal (X18).

If open processing for any of the QE71's eight connections ends with an error, read all open error code storage areas of the buffer memory of each connection for which the open request signal is on, and then perform error processing for the error code.

6

Precautions for creating application programs on the remote node side

(a) Open/close processing of connections with the QE71 side

Because the reopen processing time indicated in (b) below is required, reduce the number of connection open/close processing with the QE71 side.

* Open the connection when starting data exchange, and close the connection when a series of data exchange (multiple number of data exchanges) is completed.

(b) Open processing of connections with the QE71 side

When performing TCP/IP communication, take the time required on the QE71 side shown below into account.

- If the open processing of a connection with the QE71 (*1) completes normally, but the same connection must be closed immediately, perform close processing after at least one scan time has elapsed on the PLC CPU side following the normal completion of the open processing of the connection.

*1 This is the same when the open processing on the remote node side with which data is to be exchanged is either active or passive open.

- To perform an active open again after the close processing of the connection with the QE71 has completed, wait for at least 500 ms following the normal completion of the close processing on the QE71 side, and then perform open processing.

(c) Retry processing for data exchange errors

As for data exchange errors that may occur in application programs, create application programs so that data exchange processing that causes an error can be retried in order to assure the quality of communication (retry at least once).

However, be sure to perform retry only after normal completion/abnormal completion for the previous processing request is returned.

(d) Checking the specifications of the QE71

Check the specifications of the QE71 indicated in sections explaining the exchange function to be used.

① Data section code and exchange data capacity (see Item 3.3)

* For the QE71 side, specify the code during exchange using the exchange condition setting switch (SW2: data code setting) on the main unit.

② Division and data length of exchange messages (see Item 3.5.1)

③ Exchange procedure (see Item 3.5.2)

* While in TCP/IP communication, monitor the response reception with an application program.

Set the monitoring time larger than the TCP retransmission timer value.

Also, it is recommended to make the monitoring time larger than the TCP ULP timeout time.

④ Forced disconnection condition of connections (see Item 3.5.3)

FIXED BUFFER EXCHANGE SECTION

The fixed buffer exchange section explains the with procedure data exchange methods and the without procedure data exchange method when data is exchanged with remote node external device that uses the Ethernet interface module's fixed buffer and with the PLC CPU.

Fixed buffer exchange is begun after initial processing and open processing that is described in Chapter 5 connects the communication line.

In addition, conduct close processing and end processing during data exchange end on the corresponding communication line.

When conducting fixed buffer exchange with procedures, read Chapter 6.

When conducting fixed buffer exchange without procedures, read Chapter 7.

6. FIXED BUFFER EXCHANGE WITH PROCEDURE

This section explains the method used to conduct exchange with a remote node with procedures using the QE71's fixed buffer.

6.1 Control Format

This section explains the control format used for fixed buffer exchange with procedure.

Remote node exchange processing using the fixed buffer is conducted during the handshake with the remote node for data transmission from the PLC CPU and data reception from the remote node.

(1) The exchange processing data flow is as follows.

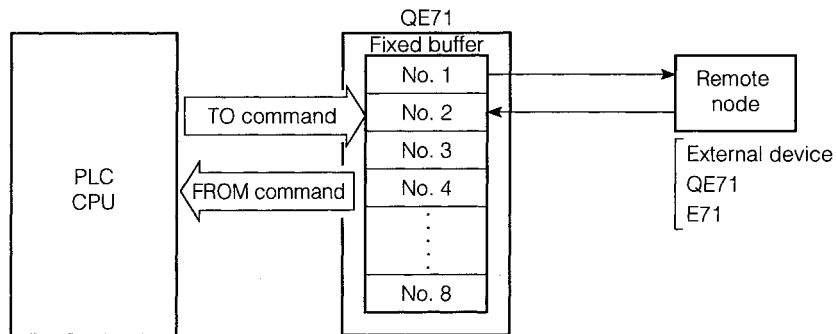

(2) Data exchange can be conducted with remote nodes in the Ethernet to which QE71 is connected and with remote nodes that are connected by a router relay function (Refer to Chapter 12). As is shown in the diagram below, the various fixed buffers (No. 1 to No. 8) are used to set the remote node with which to exchange and the usage availability (for transmission and for reception, with procedures and without procedures, etc.) when the QE71's communication line is opened (Refer to Item 5.5) to set the exchange partner for each buffer.

- ① When TCP/IP is used, a fixed buffer exchange partner setting using the parameter settings becomes valid when the QE71's open end signal changes from OFF to ON during boot-up. The exchange partner cannot be changed while the open end signal is on.
- ② When UDP/IP is used, the fixed buffer exchange partner can be changed after open processing. (It is possible to change the exchange parameter's remote node IP address and remote node port No., but is not possible to change the local station's QE71's port No.)

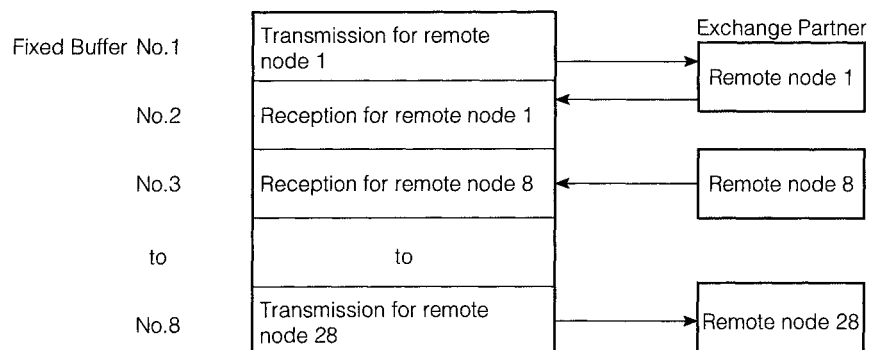

Point

- (1) When with procedures is selected during opening, random access buffer exchange (transmission or reception), and reading and writing data to the PLC CPU exchange can be conducted at the same time as fixed buffer exchange with procedure for the corresponding connection. (Refer to Item 5.1(1)*3).
- (2) When changing the exchange partner in the UDP/IP communication, do not conduct pairing setting (Refer to Item 5.5.1 1) (b) ③) and existence check setting (Refer to *2 at the end of Item 5.2.2). If these settings are made the QE71 will not operate correctly.

(3) The transmission and reception processing during data transmission and reception is given below.

① During transmission

When the transmission request signal (Y0 to Y7) is ON, the QE71 transfers the corresponding fixed buffer data to the remote node set in the corresponding area with a buffer memory address of 28H to 5FH (40 to 95). (*1)

② During reception

If there is reception from the remote node set in the corresponding area for the buffer memory addresses 28H to 5FH (40 to 95), the QE71 will conduct reception processing. (*1)

In addition, when the reception data is stored in the corresponding fixed buffer during reception processing, the QE71 updates the corresponding connection's remote node IP address and remote node port No. for the buffer memory addresses 78H to C7H (120 to 199).

If there is a reception from a remote node that is not set in the buffer memory addresses 28H to 5FH (40 to 95), the QE71 will ignore the reception data.

*1 During TCP/IP unpassive open, data is transmitted to and received from the remote nodes stored in the corresponding area for the buffer memory addresses 78H to C7H (120 to 199).

6.1.1 Transmission Control Method

This section explains about the control method when data is transmitted to the remote node by the QE71 using an example where the fixed buffer No. 1's data is transmitted to a remote node.

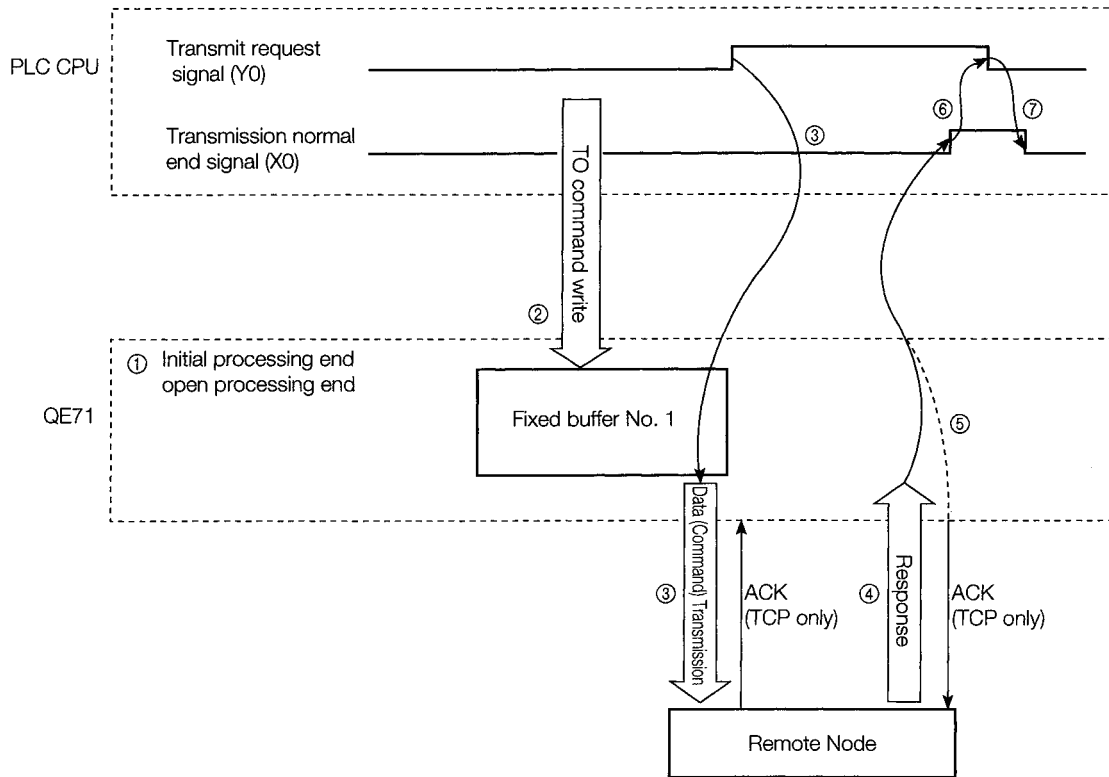

- ① The QE71 initial processing is conducted. (Refer to Items 5.2 to 5.4)
Line open processing with a remote node is conducted. (Refer to Item 5.5)
- ② The sequence program's TO command writes the transmission data length and transmission data in the QE71's fixed buffer.

The transmission data length is written to the corresponding fixed buffer's head address (1664).
The transmission data is written to the corresponding fixed buffer's head address + 1 order.

The following diagram shows an example of a 100-word transmission using fixed buffer No. 1 .

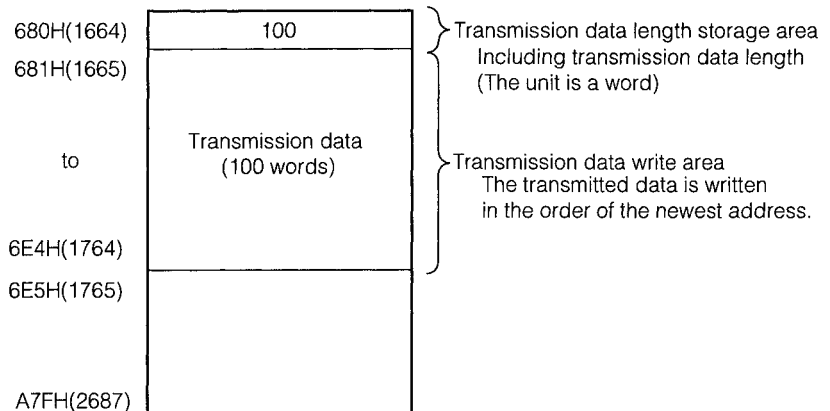

- ③ Changing the transmission request signal (Y0) to ON using the sequence program transmits the data to the node (from the parameter settings) that is specified by the fixed buffer (No.1).
- ④ When data is received from the QE71 by the specified remote node, a response is returned to the QE71.
- ⑤ The QE71 turns ON the transmission normal end signal (X0) when the response is received from the remote node.
- ⑥ When the transmission normal end signal turns on, the sequence program turns OFF the transmission request signal (Y0).
- ⑦ The transmission normal end signal is automatically turned OFF when the transmission request signal is turned to OFF.

Point

- (1) At the following times the transmission error detection signal (X1) turns ON so conduct retransmission processing when the transmission request signal turns from OFF to ON after the transmission error processing has ended.
 - ① When a response is not received within the response monitoring timer value.
 - ② When the response end code is anything other than "00H."
- (2) The QE71 conducts close processing after the transmission processing end when the open request signal (Y8) turns OFF during transmission.
- (3) The QE71 conducts close processing and end processing after transmission processing end when the initial request signal (Y19) turns OFF during transmission.

Remarks

For more details on cases when the reception of Close/Abort (RST) has occurred from the partner remote node prior to the completion of the data communication performed immediately before, refer to Remarks in 2 of Item 5.5.3.

6.1.2 Reception Control Method

This section explains the control method that the QE71 receives the data from the remote node receiving data from the remote node to the fixed buffer No.2 as an example.

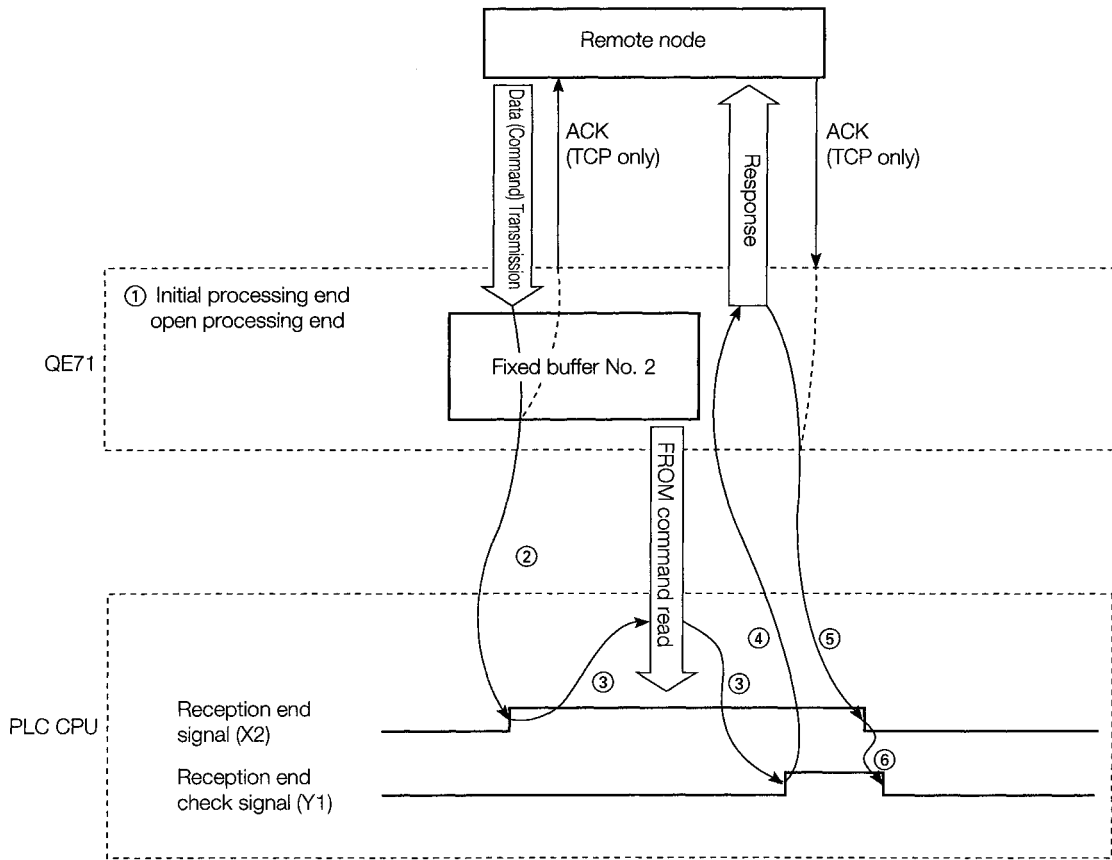

- ① The QE71 initial processing is conducted. (Refer to Items 5.2 to 5.4)
The remote node and line opening processing. (Refer to Item 5.5)
To conduct fixed buffer exchange, initial processing and open processing must be completed.

- ② When the data received from the remote node by parameter settings is stored in the fixed buffer (No.2), the QE71 turns the reception end signal (X2) ON.

The reception data length and reception data are stored in the fixed buffer.

The reception data length is stored in the corresponding fixed buffer's head address (2688).

The reception data is stored in the corresponding fixed buffer's first address + 1 order.

The following diagram shows an example of a 200-word reception using fixed buffer No. 2.

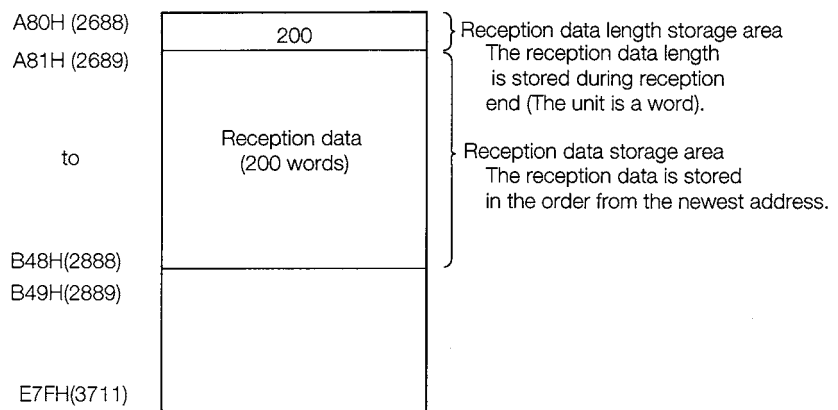

- ③ The reception data length and reception data stored in the fixed buffer are read by the sequence program's FROM command when the reception end signal is turned ON.

At the same time the reception end check signal (Y1) is turned ON by the sequence program.

- ④ The QE71 returns a response to the remote node (by the parameter settings) when the reception end check signal is turned ON.
- ⑤ When the response returned is ended, the QE71 automatically turns OFF the reception end signal.
- ⑥ The reception end check signal is turned OFF by the sequence program when the reception end signal is turned OFF.

Point

- (1) The reception end signal (X2) does not turn ON during error data reception.
In addition, the data is not stored in fixed buffer No. 2.
- (2) When the open request signal (Y9) turns OFF during reception, the QE71 immediately performs close processing.
- (3) When the initial request signal (Y19) turns OFF during reception, the QE71 immediately conducts close processing and end processing.

Remarks

For more details on cases when the reception of Close/Abort (RST) has occurred from the partner remote node prior to the completion of the data communication performed immediately before, refer to Remarks in [2](#) of Item 5.5.3.

6.2 Data Format

This section explains the data format used when transmission and reception are conducted between the QE71 and a remote node.

The communication data is comprised of a header and application data as shown below.

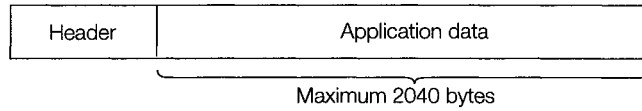

6.2.1 Header

The header is the header for TCP/IP or UDP/IP. For the QE71, the header is added or deleted by the QE71, so it is not necessary for the user to set this.

(Header Size Breakdown)

① For TCP/IP

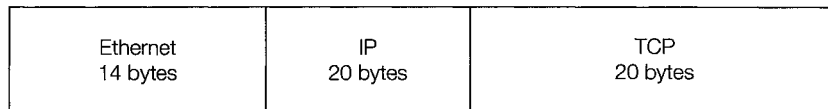

② For UDP/IP

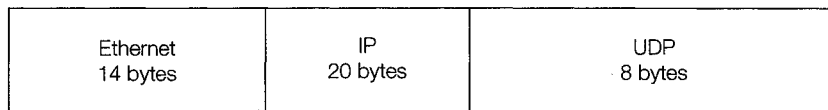

6.2.2 Application Data

As shown below, the application data can display the data code in binary or ASCII code.

The binary and ASCII settings are performed using the exchange condition setting switches (SW2: data code setting) of the QE71. (For details regarding the setting method, refer to Item 4.3.2.)

1 Format

(a) During command transmission and reception

① During binary code exchange

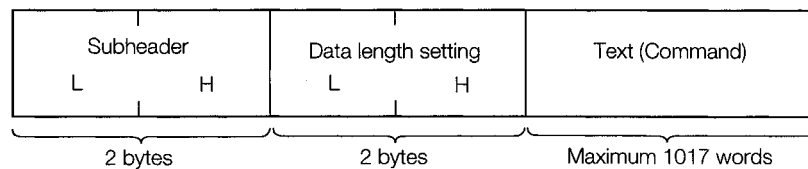

② During ASCII code exchange

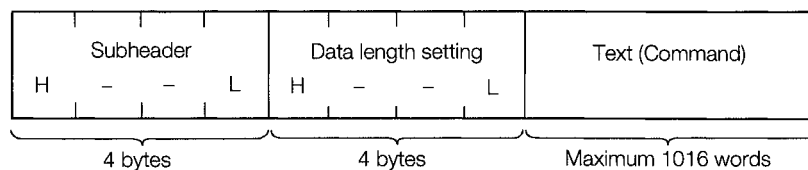

(b) During response transmission and reception

① During binary code exchange

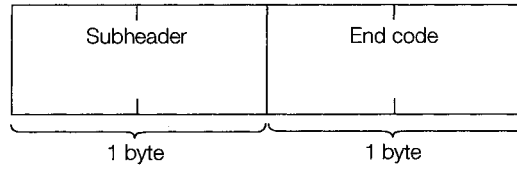

② During ASCII code exchange

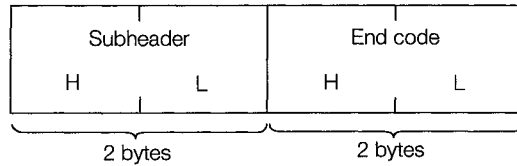

2

Subheader

The subheader format is shown below.

For the QE71, the header is added or deleted by the QE71, so it is not necessary for the user to set this.

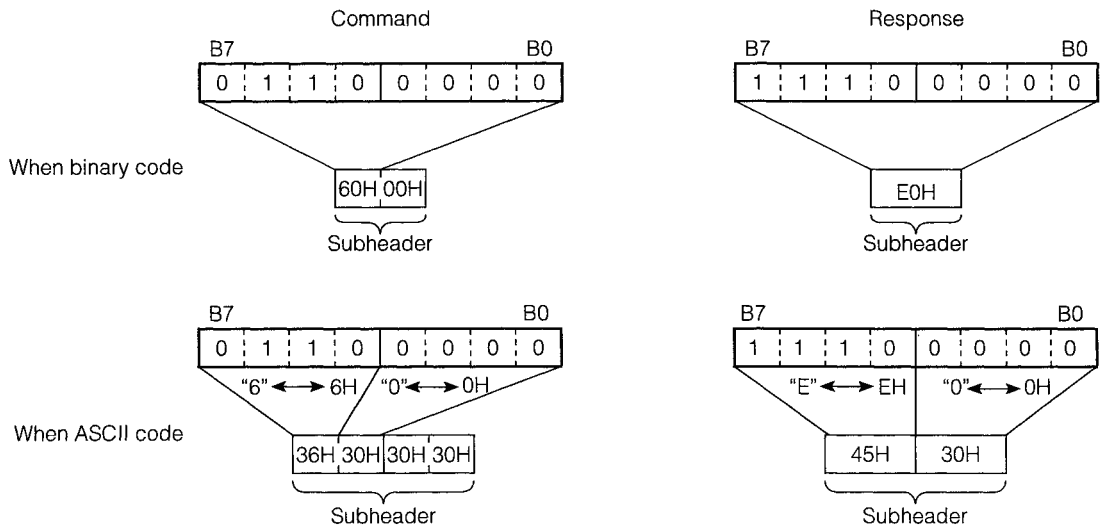
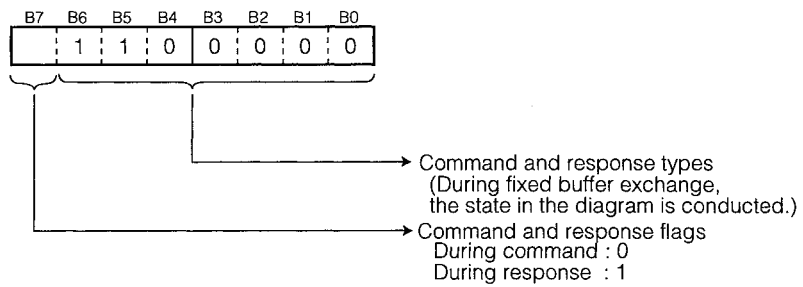

3 Data length setting

Shows the text (command) area data amount.

Point

- (1) The amount of exchanged data that can be handled by the PLC CPU when binary code is specified is a maximum of 1017 words.
The data length setting range is from 1 to 1017. The unit is a word.
- (2) The amount of exchanged data that can be handled by the PLC CPU when ASCII code is specified is a maximum of 508 words. This is approximately one half of the exchanged data amount when binary code is specified. The data length is communicated using ASCII code ("0001" to "01FC") when the number of words is expressed in hexadecimal notation. The setting range is from 1 to 508. The unit is a word.

4 Text (Command)

This section explains the command and response format during fixed buffer exchange.

When binary code is specified

Command format

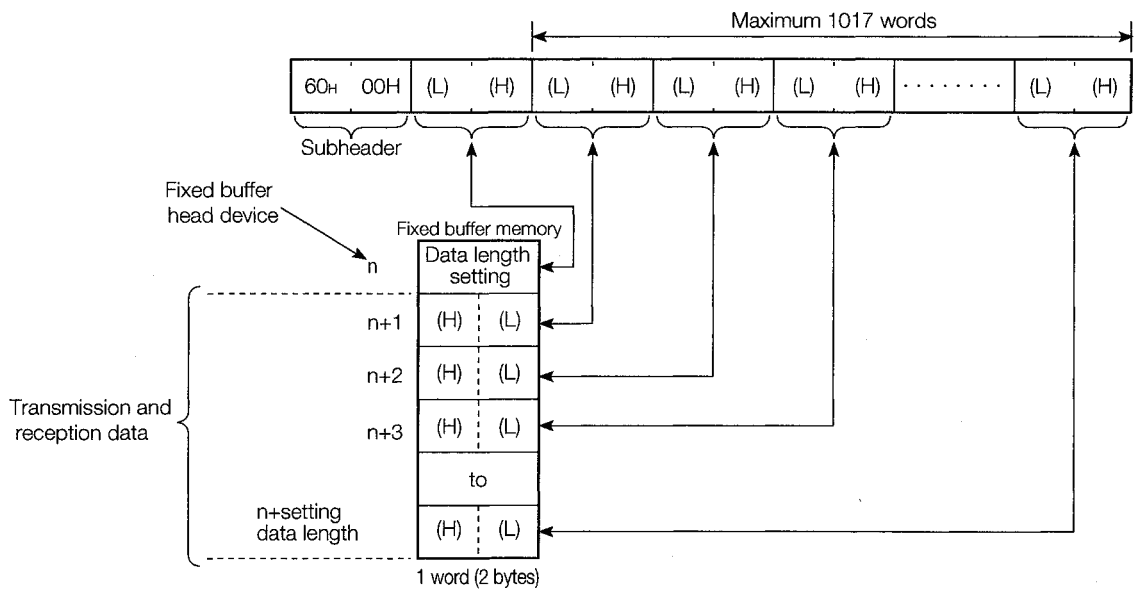

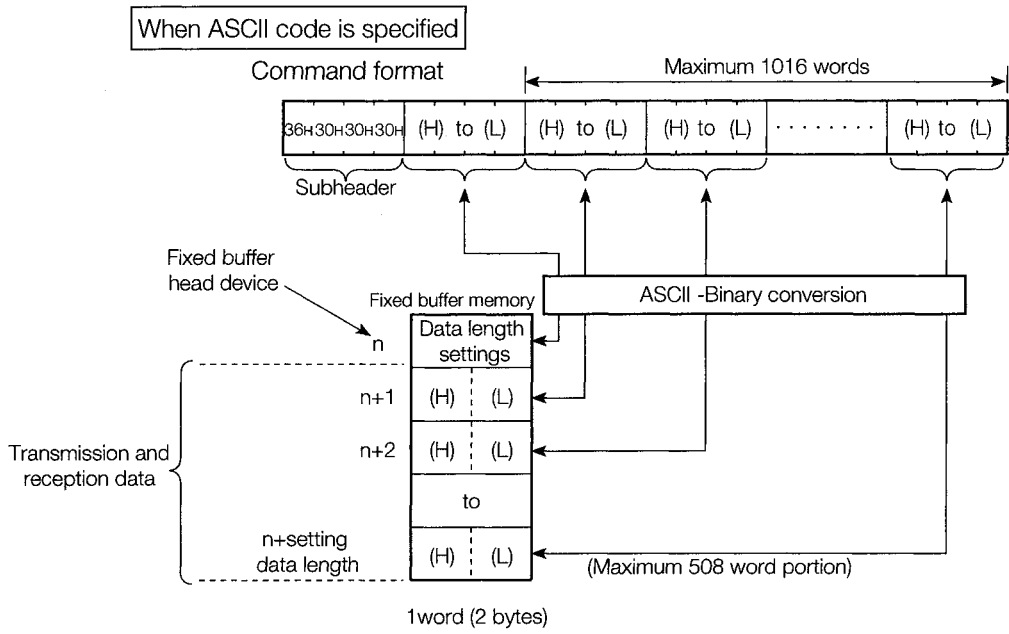

(Example)

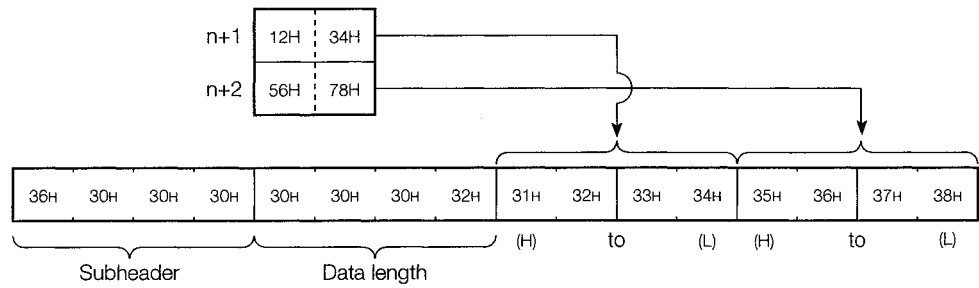

5 End code

Shows the end code added by the response during fixed buffer exchange. The end code is stored in the buffer memory exchange state storage area.

When binary code is specified		When ASCII code is specified	
00H	Normal end	30H-30H	Normal end
50H	Command and response type undefined error	35H-30H	Command and response type undefined error
52H	Number of data words defective	35H-32H	Number of data words defective
		35H-34H	ASCII conversion error

For details regarding error codes, refer to Chapter 17.

6.3 Programming

This section explains programming method for using the fixed buffer to conduct exchange between the QE71 and a remote node with procedures.

6.3.1 Programming Creation Precautions

- (1) Fixed buffer exchange can only be conducted when the open end signal (X10 to X17) is turned ON. Initial processing and communication line open processing must be completed. (Refer to Chapter 5)
- (2) The parameter settings are entered into the QE71 when the open request signal (Y8 to YF) turns from OFF to ON during boot up. Except for those cases shown in the following (3), the control contents cannot be changed even if the parameter contents are written over while the open end signal (X10 to X17) is ON.
- (3) When using a connection opened by UDP, the exchange parameters setting area's exchange address setting area setting values can be changed before data is transmitted or received, and the exchange partner remote node can be switched. Therefore, data can be transmitted in order to multiple remote nodes, so to prevent exchange trouble from occurring, switch the partner remote node and conduct transmission and reception.
- (4) The data length that is specified (stored) in the buffer memory when exchange with procedures is conducted, uses units of one word. If the buffer memory transmission data length exceeds the range during transmission, there will be an exchange error and the transmission will not be conducted.
- (5) When data is received from a fixed buffer, be sure the reception end check signal (Y0 to Y7) is ON during reception end (the point at which the reception end signal turns ON).

A response is returned to the remote node when the reception end check signal turns ON, and the following reception data is stored in the corresponding fixed buffer. If the reception end check signal does not come ON, a response is not returned to the remote node, so an exchange error occurs at the remote node end.

- (6) When receiving data from remote nodes the data length in the command being transmitted from the remote node must not exceed the range shown in Item 6.2.2 3 Point.
When the QE71 receives a command with a data length that exceeds the settable range, it might conduct closed processing for the corresponding connection without transmitting a response. Check using the I/O signal's open end signal (X10 to X17) or the open error code area (address 7CH, 86H, ..., error code C040H) in the buffer memory's exchange status storage area.
- (7) For data (command) transmission, the next data (command) should be sent after the completion of data communication (such as after the reception of a response) for the transmission of the previous data (command).

6.3.2 Program Creation Procedure

This section explains the fixed buffer data transmission and reception program creation procedures.

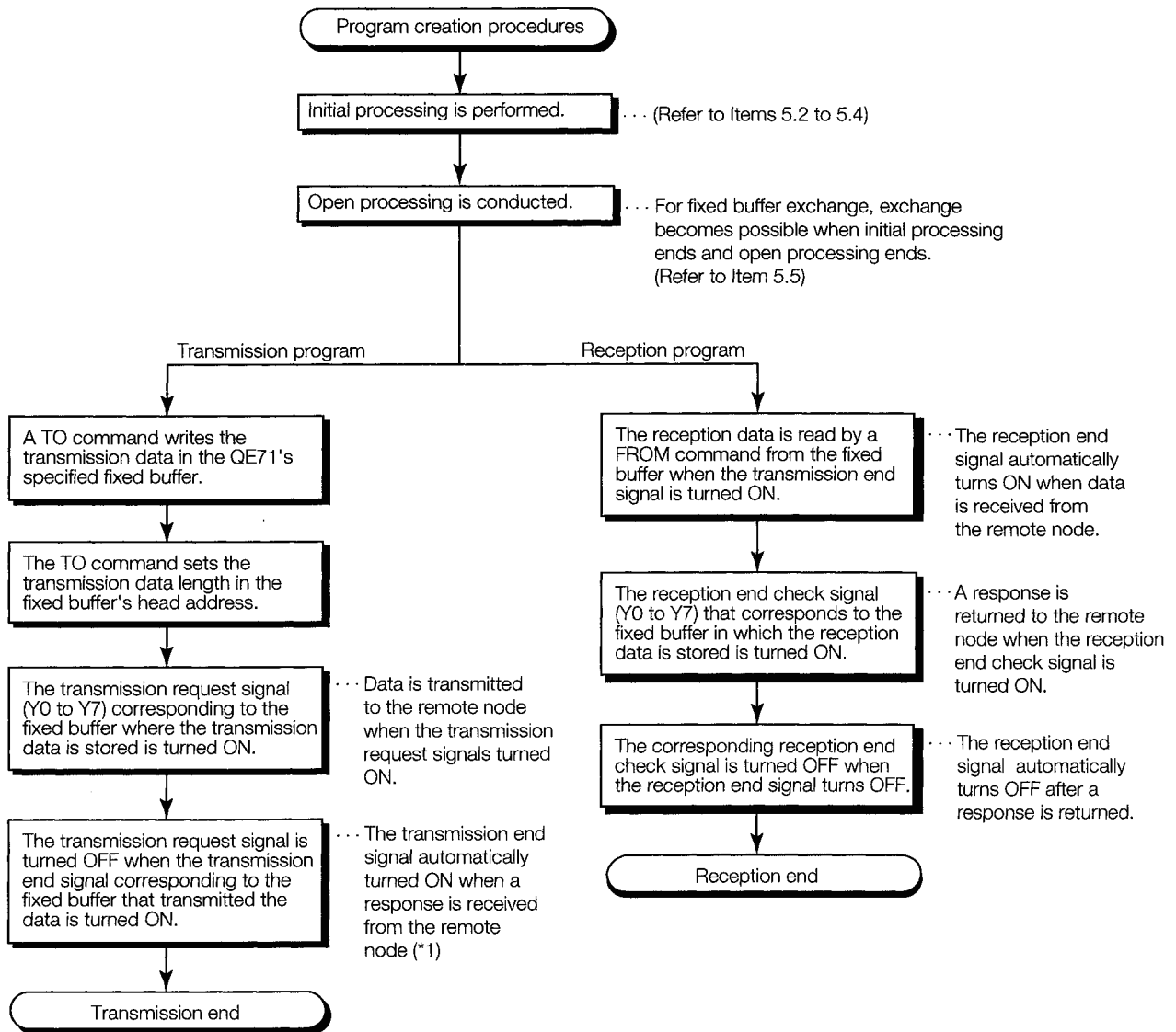

*1 When the transmission error detection signal turns ON, the information for individual connections in the transmission state storage area (transmission error code, end code) is handled as described in Chapter 17.

6.3.3 Example Fixed Buffer Exchange Program (With Procedure)

This section explains the programming method for conducting data exchange with a remote node using a fixed buffer.

(Program Conditions)

- (1) All connection exchange parameters are set to those parameters specified in Item 5.5.5.
- (2) The fixed buffer transmission data is stored in D300 to D303.
- (3) The fixed buffer reception data is stored in D500 to D503.
- (4) The error code and end code storage destination is allotted as follows.

- D108 Transmission error code (when transmission)
- D109 Reception end code
- D110 Transmission error code (when reception)

Fixed buffer No.1 Transmission Program

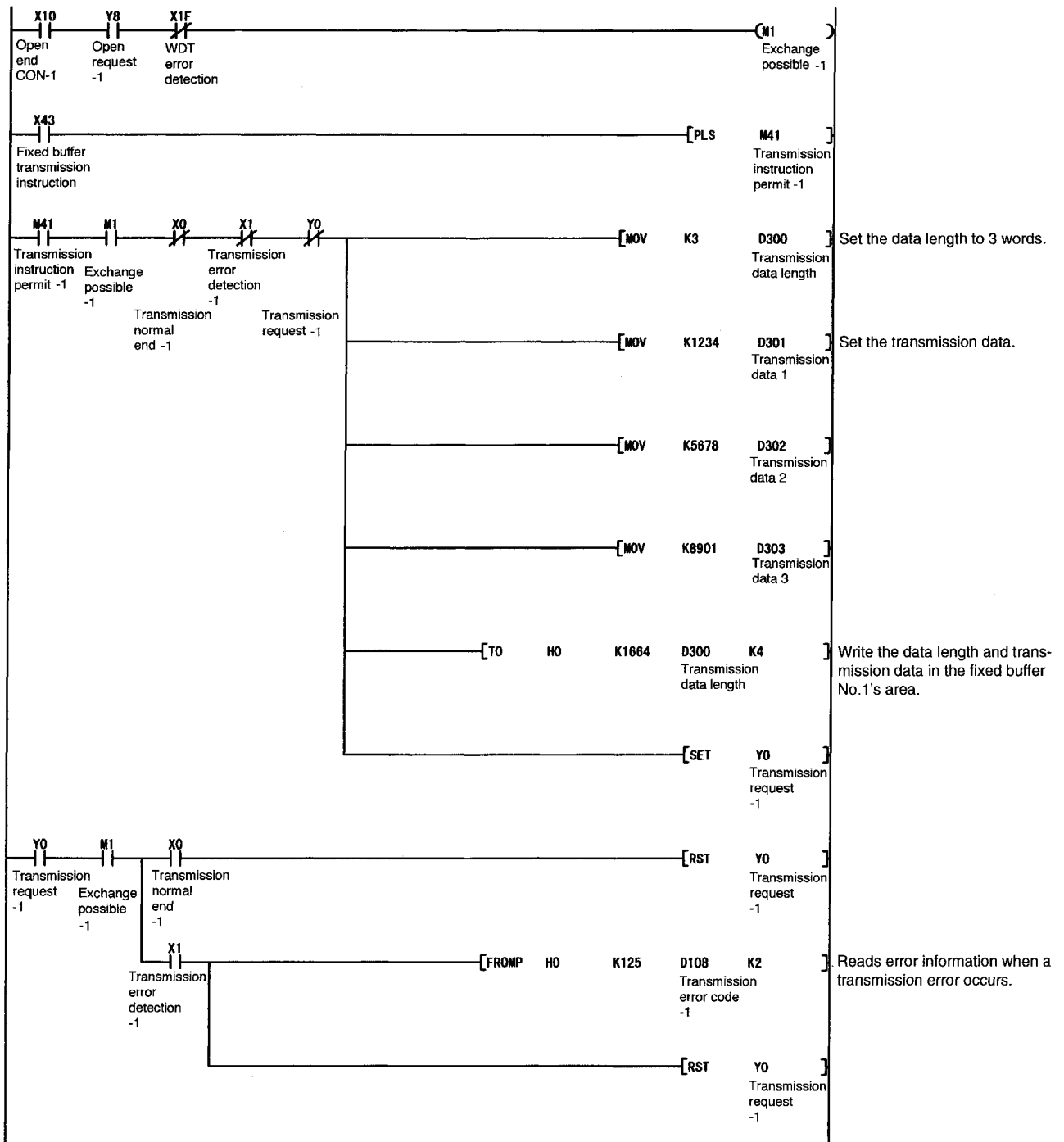

Fixed Buffer No.2 Reception Program

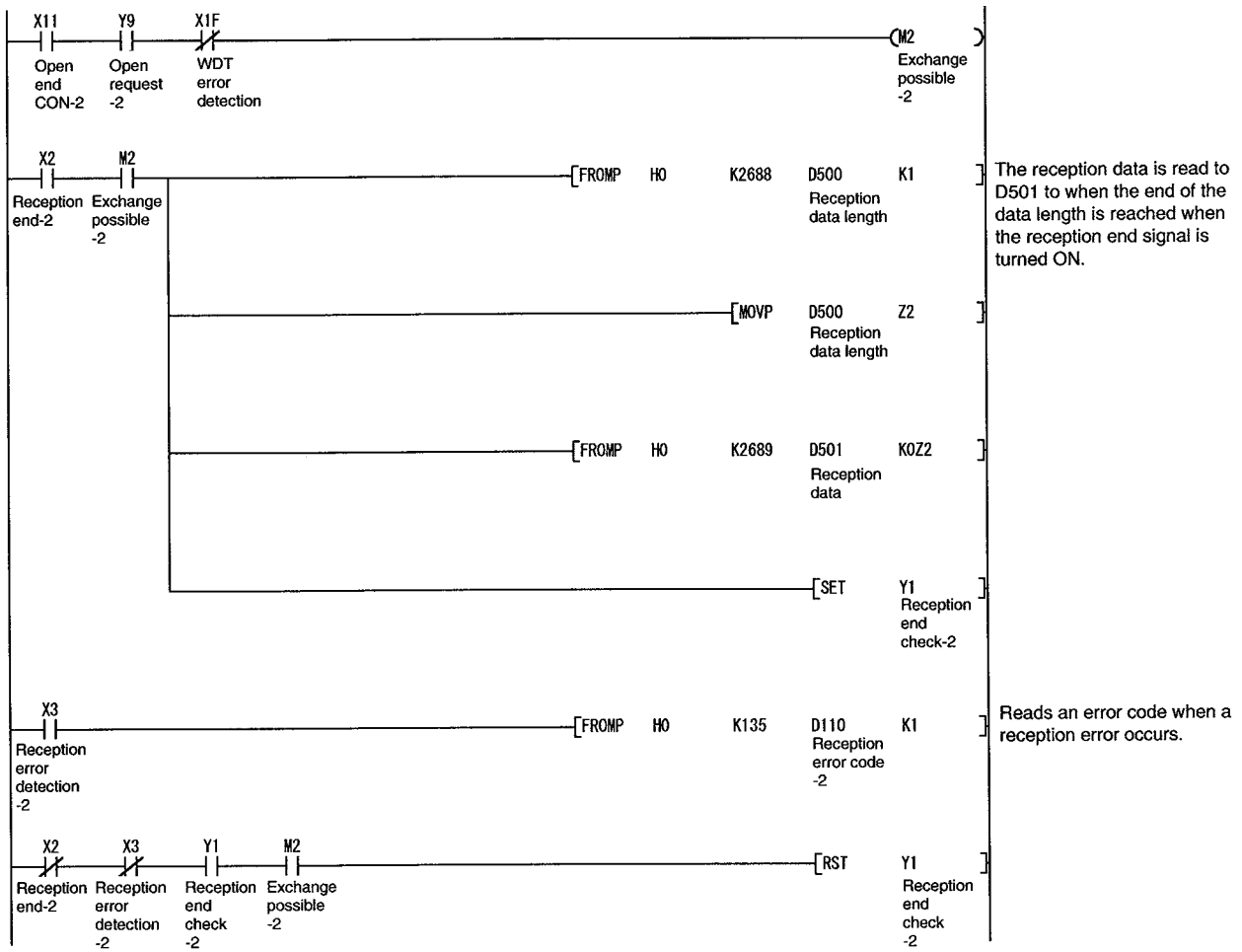

7. FIXED BUFFER EXCHANGE WITHOUT PROCEDURE

This section explains the method for exchanging with a remote node without procedure using the QE71's fixed buffer.

Point

Following is an overview of the difference from fixed buffer exchange using with procedure.

- ① During data transmission, the data is transmitted to the fixed buffer without the message application adding a subheader or a data length. During data reception, the header is removed from the received message and all the data is stored in the fixed buffer.
- ② A response to the data reception is not transmitted.
- ③ Conducts exchange in binary code regardless of the exchange condition setting switch (SW2: data code setting) setting of the QE71.
- ④ The application data portion that can be handled by one exchange is 1 to 2046 bytes.
- ⑤ The corresponding connection becomes for fixed buffer exchange without procedure special use. Fixed buffer exchange with procedure, random access buffer exchange, and reading and writing data in the PLC CPU exchange are not conducted at the same time as fixed buffer exchange without procedure.

7.1 Control Format

This section explains the control format used to conduct fixed buffer exchange without procedure.

Fixed buffer remote node exchange processing can be conducted without procedure for data transmission from the PLC CPU and data reception from a remote node.

- (1) The exchange processing data flow is shown below.

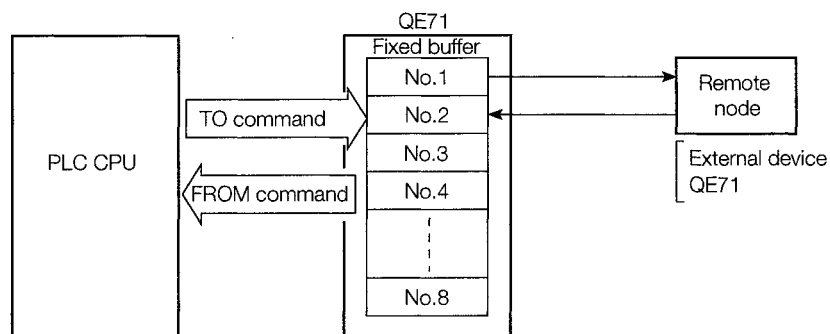

- (2) Data exchange can be conducted for remote nodes connected in the Ethernet by the QE71, and for remote nodes connected by router relay functions (Refer to Chapter 12).

As shown in the diagram on the following page, the fixed buffers (No.1 to No.8) are used to set the remote nodes to which exchange will be conducted and the usage availability (for transmission/reception, without procedure/with procedure, etc.) to be opened in the QE71's communication line (Refer to Item 5.5), and to set the exchange partners for the buffers.

- ① The parameter settings fixed buffer exchange partner setting when TCP/IP is used, is valid when the QE71's open end signal turns from OFF to ON during boot up. The exchange partner cannot be changed while the open end signal is ON.

- ② The fixed buffer exchange partner can be changed after open processing when UDP/IP is used. (The exchange parameter's remote node IP address and remote node port No. can be changed, but the local station QE71's port No. cannot be changed.)

(Example)

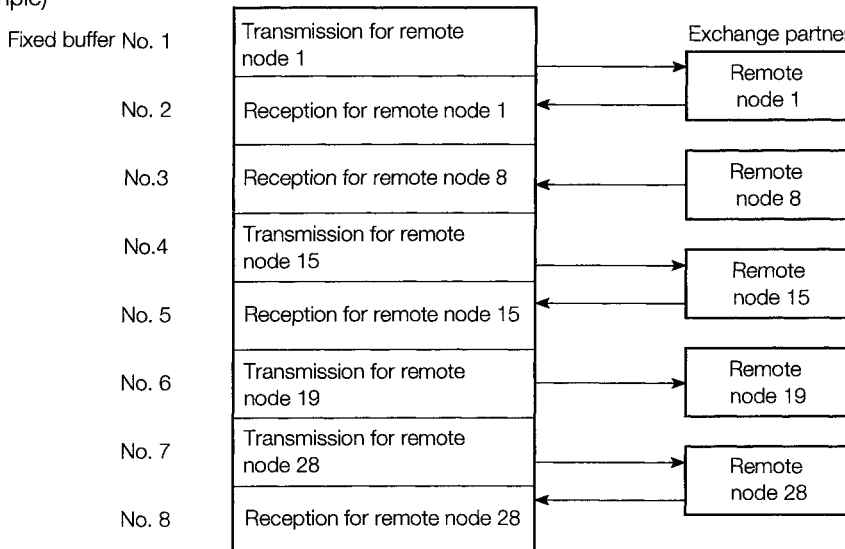

Point

- ① Select without procedure and during open the corresponding connection will be changed to special use for fixed buffer transmission/reception without procedure. (Refer to Item 5.1(1)*3). Fixed buffer exchange with procedure, random access buffer exchange, and reading and writing data in the PLC CPU exchange cannot be conducted at the same time as fixed buffer exchange without procedure.
- ② When changing the exchange partner in the UDP/IP communication, do not perform pairing setting (Refer to Item 5.5.1 1) (b) ③), or existence check setting (Refer to *2 at the end of Item 5.2.2).
If these are set, the QE71 will not operate normally.

- (3) The transmission and reception processing during data transmission and reception is as follows.

① During transmission

When the transmission request signal (Y0 to Y7) is ON, the QE71 transmits the corresponding fixed buffer's data to the remote node set in the buffer memory address 28H to 5FH (40 to 95) corresponding area. (*1)

② During reception

If there is reception from a remote node set in the buffer memory address 28H to 5FH (40 to 95) subject area, the QE71 will perform reception processing. (*1) In addition, when reception data is stored in the subject fixed buffer by reception processing, the QE71 updates the buffer memory address 78H to C7H (120 to 199) corresponding connection's remote node IP address and remote node port No.

If there is a reception from remote nodes that are not set in the buffer memory address 28H to 5FH (40 to 95), the QE71 will ignore the reception data.

For details refer to Item 7.3.2 remarks.

*1 When the TCP/IP unpassive open, data is transmitted to and received from the remote node stored in the buffer memory address 78H to C7H (120 to 199) corresponding area.

7.1.1 Transmission Control Method

This section explains the control method for transmitting data to the remote node from the QE71 using transmission of the fixed buffer No.1 data to a remote node.

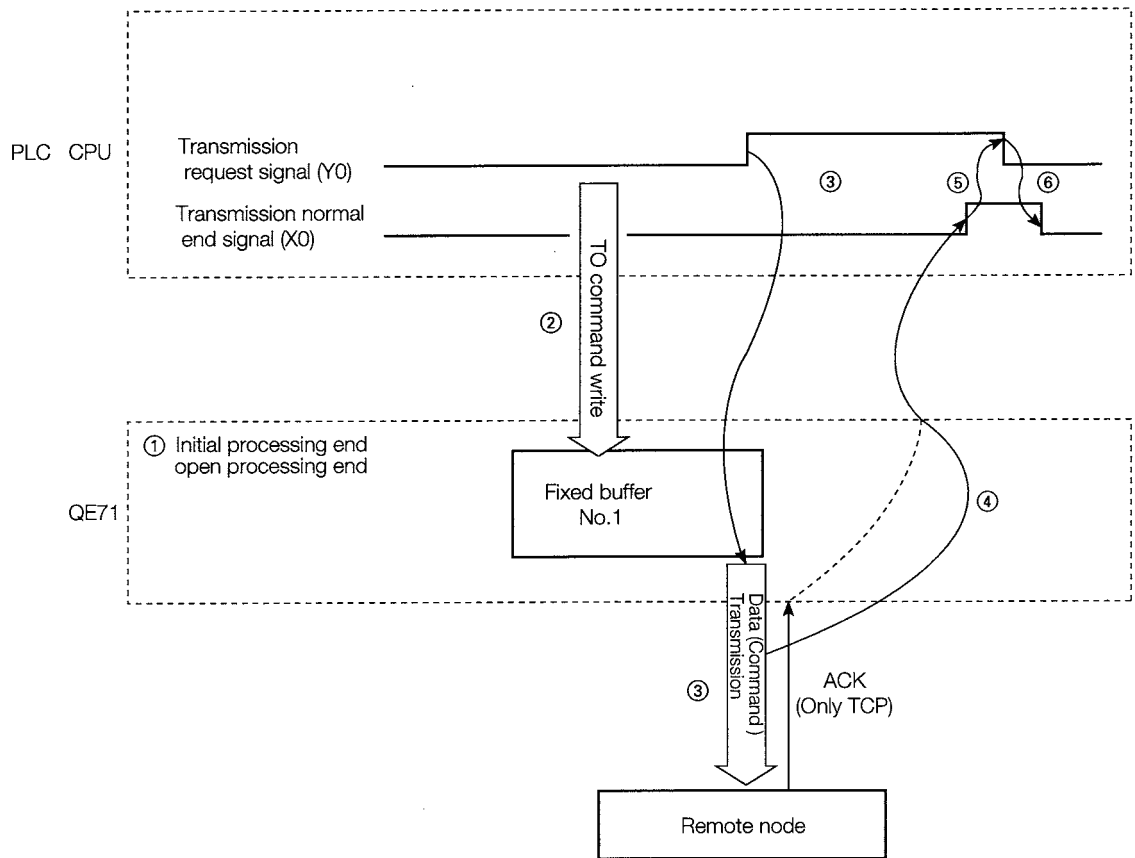

- ① Performs QE71 initial processing. (Refer to Items 5.2 to 5.4)
Performs line open processing with the remote node. (Refer to Item 5.5)
- ② The sequence program's TO command writes the transmission data length and transmission data in the QE71's fixed buffer.
The transmission data length is written to the corresponding fixed buffer's head address (1664).
The transmission data is written starting from the corresponding fixed buffer's head address + 1 order.
The following figure shows an example of a 200-byte transmission using the fixed buffer No.1.

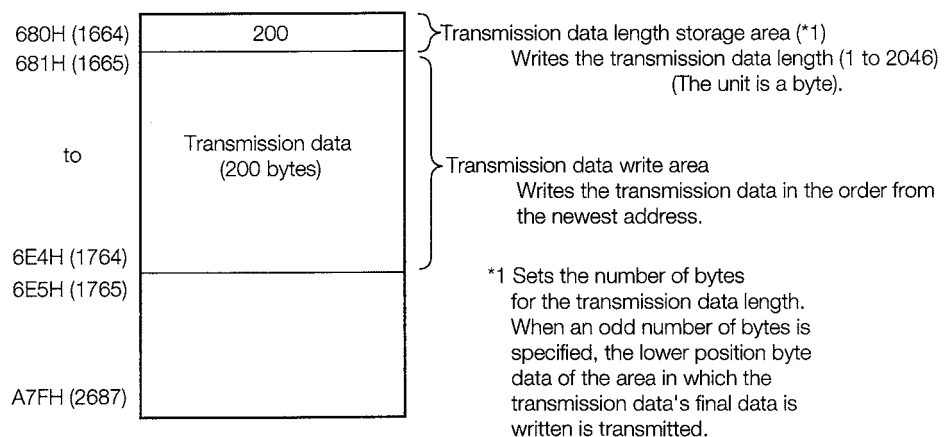

- ③ When the transmission request signal (Y0) is turned ON by the sequence program, the data is transmitted as it is to the specified node (by the parameter settings) from the fixed buffer (No.1).
- ④ The QE71 turns the transmission normal end signal (X0) ON when the data transmission ends.
- ⑤ The turning ON of the transmission normal end signal causes the sequence program to turn OFF the transmission request signal (Y0).
- ⑥ When the transmission request signal turns OFF, the transmission normal end signal automatically turns OFF.

Point

- (1) When communicating by UDP/IP, need attention for the items described below.
 - ① When the PLC CPU and the remote node are not connected by a communication line due to disconnection of the connection cable, the transmission normal end signal (X0...) and transmission error detection signal (X1...) are not turned ON if data was transmitted to the remote node by the PLC CPU.
 - ② When data is transmitted to the remote node from the PLC CPU, conduct the time out check until transmission is ended using the PLC CPU. (The user can adjust the time out time) When a time out occurs, turn OFF the transmission request signal (Y0...), check the communication line with the partner remote node, and conduct connection processing for the troubled location.
- (2) Except (1) in above, when the transmission does not end normally, the transmission error detection signal (X1) turns ON. (The exchange normal end signal (X0) does not turn ON.) In this case, reconduct transmission processing by turning the transmission request signal from off to on after the transmission error processing is completed.
- (3) When the open request signal (Y8) turns off during transmission, the QE71 conducts closed processing after the transmission processing end.
- (4) When the initial request signal (Y19) turns off during transmission, the QE71 conducts closed processing and end processing after transmission processing end.

Remarks

For more details on cases when the reception of Close/Abort (RST) has occurred from the partner remote node prior to the completion of the data communication performed immediately before, refer to Remarks in 2 of Item 5.5.3.

7.1.2 Reception Control Method

This section explains the control method that the QE71 receive the data from the remote node receiving to the fixed buffer No.2 as an example.

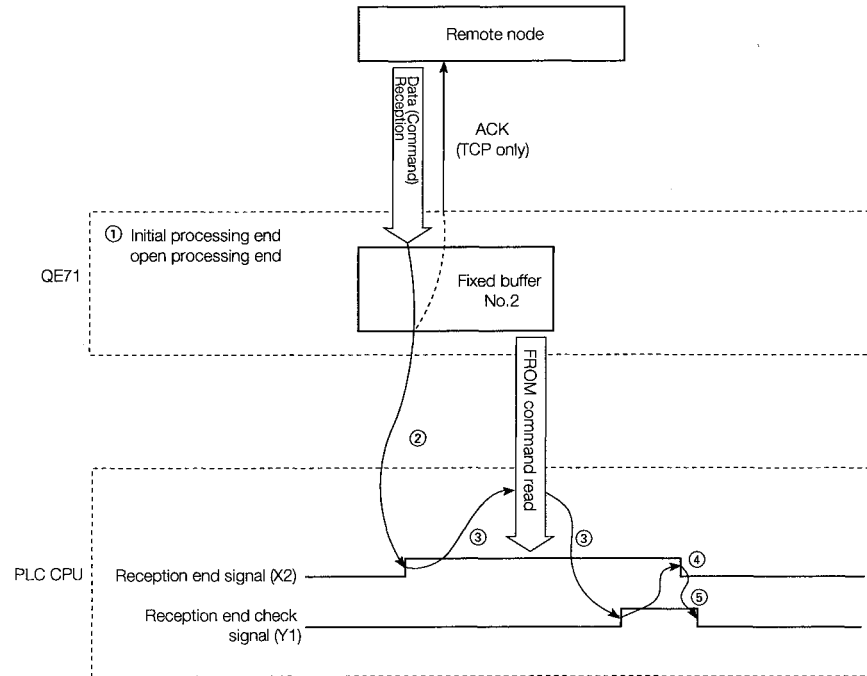

- ① Conducts QE71 initial processing. (Refer to Items 5.2 to 5.4)
- Conducts line open processing to the remote node. (Refer to Item 5.5)
- To conduct fixed buffer exchange, initial processing and open processing must be completed.

- ② The QE71 will turn on the reception end signal (X2) when the reception data is stored as is from the remote node by parameter setting into the fixed buffer (No.2).

The reception data length and reception data are stored in the fixed buffer.

The reception data length is stored in the corresponding fixed buffer first address (2688).

The reception data is stored in order starting from the fixed buffers No.1 to 8 first address +1.

The following figure shows an example of a 400-byte reception using fixed buffer No.2.

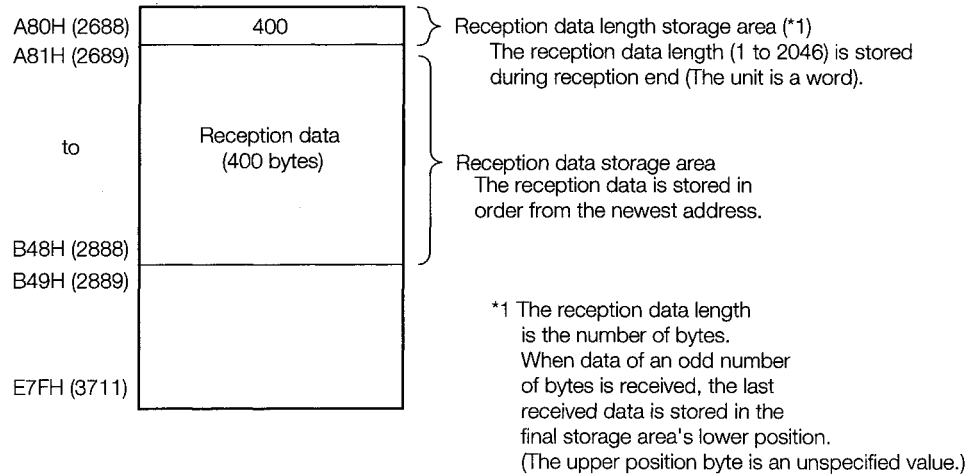

- ③ The reception data length and reception data stored in the fixed buffer is read by the sequence program's FROM command when the reception end signal turns on. At the same time, the sequence program turns on the reception end check signal (Y1).
- ④ The QE71 automatically turns off the reception end signal.
- ⑤ The sequence program turns off the reception end check signal when the reception end signal turns off.

Point

- (1) The reception end signal (X2) does not turn on during error data reception. In addition, the data is not stored in the fixed buffer No.2.
- (2) If the open request signal (Y9) turns off during reception, the QE71 immediately conducts close processing.
- (3) If the initial request signal (Y19) turns off during reception, the QE71 immediately conducts close processing and end processing.

Remarks

For more details on cases when the reception of Close/Abort (RST) has occurred from the partner remote node prior to the completion of the data communication performed immediately before, refer to Remarks in [2] of Item 5.5.3.

7.2 Data Format

The section explains the data format used when transmission and reception are conducted between the QE71 and a remote mode.

The communication data is comprised of a header and application data as shown below.

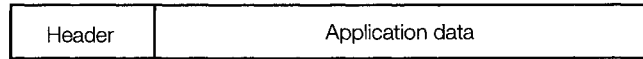

1

Header

The header is the header for TCP/IP or UDP/IP. For the QE71, the header is added or deleted by the QE71, so it is not necessary for the user to set this.

(Header size breakdown)

① For TCP/IP

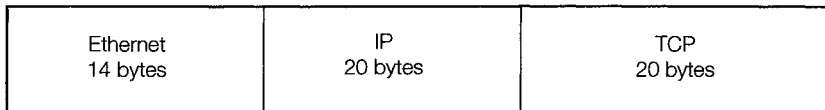

② For UDP/IP

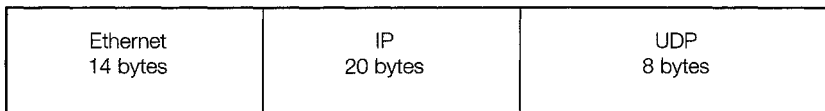

2

Application data

The application data shows the data code in binary code. The binary and ASCII settings can be ignored using the exchange condition setting switch (SW2: data code setting) of the QE71.

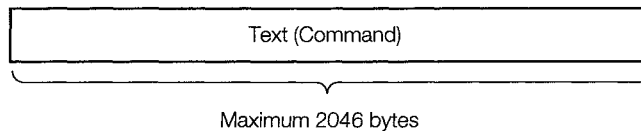

Remarks

The subheader and data length attached during exchange by the fixed buffer with procedure, do not exist when it is without procedure. All the data is handled as valid text.

7.3 Simultaneous Broadcast Communication When Using UDP/IP

When UDP/IP is used to conduct fixed buffer exchange without procedure, a simultaneous broadcast to all QE71 installation stations connected to the same Ethernet as the QE71.

This makes it possible to write, etc., the same data to all stations.

Point

- (1) For simultaneous broadcast communication, the remote node connected to the same Ethernet is required to get rid of reading when the received message by simultaneous broadcast is not necessary.
- (2) For simultaneous broadcast communication, the user arranges the simultaneous broadcast transmission, reception special port No., and specifies the port No.

7.3.1 Simultaneous Broadcast Communication Transmission

When conducting open processing for the partner remote node IP address to which data will be sent as FFFFFFFFH, simultaneous broadcast communication transmission can be conducted. During simultaneous broadcast communication transmission, the QE71 changes the request destination IP address to FFFFFFFFH, and transmits the data on the Ethernet.

(Example) When connection 1 is used

Address	Buffer memory	
20H(32)	0300H	Set without procedure, UDP, and for transmission.
to	to	
28H(40)	QE71 Port No.	Makes the remote node IP address to a simultaneous broadcast address.
29H(41)	FFFFH	
2AH(42)	FFFFH	Makes the remote node port No. to the simultaneous broadcast port No. (arranged by the user)
2BH(43)	Remote node port No.	

During the situation shown in the figure above, the QE71 makes all of the request destination IP addresses = FF.FF.FF.FFH, makes the request destination port No. equal the remote node port No., and transmits the fixed buffer's data.

7.3.2 Simultaneous Broadcast Communication Reception

Making the partner remote nodes IP address to which the data will be received FFFFFFFFH and the port No. to FFFFH and conducting open processing will receive process all of the corresponding reception data as simultaneous broadcast communication data.

(Example) When connection 1 is used

Address	Buffer memory	
20H(32)	0301H	Set without procedure, UDP, and for reception
to	to	
28H(40)	QE71 Port No.	
29H(41)	FFFFH	Makes the remote node IP address to a simultaneous broadcast address.
2AH(42)	FFFFH	
2BH(43)	FFFFH	Makes the remote node port No. to the simultaneous broadcast port No.

During the situation shown in the above figure, the QE71 changes all of the bits in the reception data request destination IP addresses local station class host address range to 1, and if the request destination port No. equals the QE71's port No., the reception data is stored in the fixed buffer and the reception end signal (X0) is turned on.

In addition, when the reception data is stored in the corresponding fixed buffer, the QE71 updates the buffer memory address 78H to C7H (122 to 199) of the corresponding area's remote node IP address and the remote node's port No.

When checking the data transmission origin, read the above buffer memory (exchange state storage areas information area by connection).

Remarks

Following is shown an overview of the QE71's internal processing when there is reception using without procedure and reception using simultaneous broadcast communication.

The values set in the buffer memory address 0H to 1H, 28H to 5FH, are used for local stations QE71's IP address and port No., and remote nodes IP address and port No.

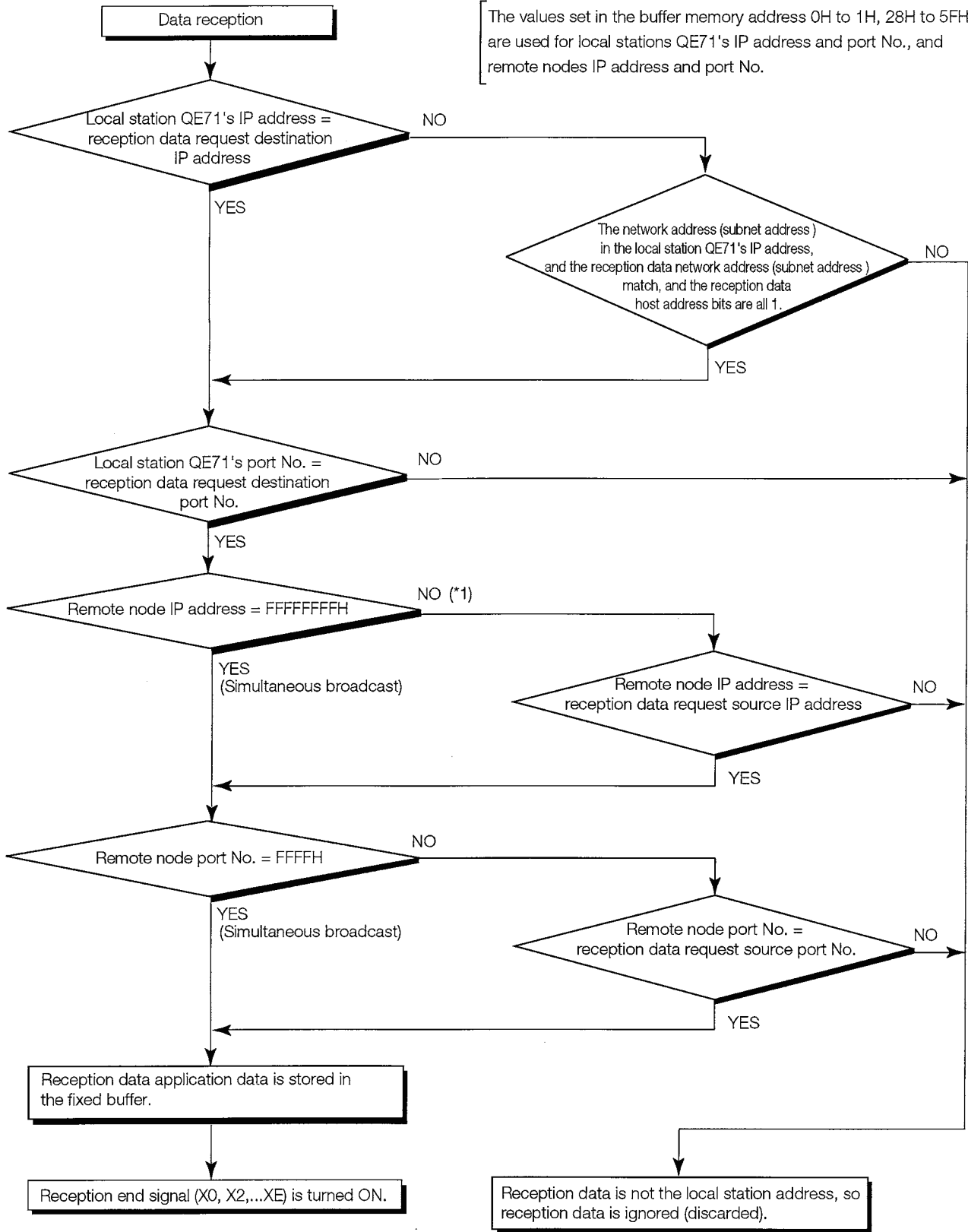

*1 When all of the bits in the range that represents the reception data request destination IP address' host address are 1, processing is conducted on the yes side.

7.3.3 Precautions When Using Simultaneous Broadcast Communications Functions

Following are precautions when conducting simultaneous broadcast communication with fixed buffer exchange without procedures.

1 For simultaneous broadcast communication, the user will arrange the simultaneous broadcast transmission/reception special port No. and specify the port No. for it.

2 The simultaneous broadcast communication transmission message is set to all the nodes on the Ethernet to which the QE71 is connected.

The remote node connected to the same Ethernet is required to get rid of reading when the received message by simultaneous broadcast is not necessary.

* When the transmitted message is unrelated to a particular node, the particular node will discard the received message. In addition, even if a particular node is the subject station, do not return a response. The QE71 will automatically perform this processing.

3 The application data amount that can be handled at one time for transmission or reception is a maximum of 2046 bytes. If data of 2047 bytes or more must be transmitted or received, divided it at the transmission origin.

4 When the reception data is read to the PLC CPU when the reception end signal (X0, X2...XE) is turned on, be sure to turn on the corresponding reception end check signal (Y0 to Y7).

Turning on the reception end check signal (Y0 to Y7) makes it possible for the QE71 to store the received data in the corresponding fixed buffer.

Not turning on the reception end check signal (Y0 to Y7) could cause the reception data to be discarded.

5 When performing simultaneous broadcast, set up "Destination does not check existence" during the open processing for the corresponding connection.

Remark

Until the previous reception processing is completed, the QE71 temporarily stores the data received after that in its internal buffer for the OS.

Data received in excess of the internal buffer capacity (approximately 40k bytes) by simultaneous broadcast are discarded.

For communication using the fixed buffer (with procedure), etc., it is not necessary to consider the above-mentioned internal buffer since the QE71 waits for a response message after transmitting a command message to the remote node, and upon reception of the response message, it transmits the next command message.

7.4 Programming

This section explains the programming method for conducting exchange between the QE71 and the remote node using the fixed buffer and without procedure.

7.4.1 Precautions When Creating Programs

1 Fixed buffer exchange can be conducted when the open end signal (X10 to X17) is turned on. The initial processing and communication line open processing must be completed. (Refer to Chapter 5)

2 The parameter setting contents are taken into the QE71 when the open request signal (Y8 to YF) is turned from off to on at the start up.

Except for that in **3** below, the control contents cannot be changed even if the parameter contents are written over while the open end signal (X10 to X17) is on.

3 Following are cases when using a connection that is UDP open.

(a) The settings values of the exchange parameter setting area's exchange address setting area can be changed before transmission or reception, and the exchange partner remote node can be changed.

Therefore, data can be transmitted in order to multiple nodes, so conduct transmission and reception by switching the partner remote nodes to prevent exchange trouble from occurring.

(b) When transmission data, need attention for the items described below.

① When the PLC CPU and the remote node are not connected by a communication line due to disconnection of the connection cable, the transmission normal end signal (X0...) and transmission error detection signal (X1...) are not turned ON if data was transmitted to the remote node by the PLC CPU.

② When data is transmitted to the remote node from the PLC CPU, conduct the time out check until transmission is ended using the PLC CPU. (The user can adjust the time out time) When a time out occurs, turn OFF the transmission request signal (Y0...), check the communication line with the partner remote node, and conduct connection processing for the troubled location.

4 When opened by selecting without procedure, the subject connection becomes a fixed buffer transmission/reception special use without procedure, so fixed buffer exchange with procedure, random access buffer exchange, and reading and writing data in the PLC CPU exchange, cannot be conducted at the same time as fixed buffer exchange without procedure.

5 The data length specified (stored) in the buffer memory during exchange without procedure is byte units. (The data length during exchange with procedure is in word units.)

When the buffer memory transmission data length exceeds the range (1 to 2046) during data transmission, an exchange error will occur and transmission will not be conducted.

6 When receiving data using the fixed buffer, be sure to turn on the reception end check signal (Y0 to Y7) during reception end (at the point the reception end signal turns on).

Turning on the reception end check signal stores the following reception data in the corresponding fixed buffer.

7 When using without procedure, the message does not have a data length.

The QE71 turns on the reception end signal (X0, X2,... XE) after the received message (packet) size is stored in the reception data length storage area.

It is recommended that check steps, such as including data length and data type codes in the message application data, be used to allow the receiving end to identify the number of application data bytes and the data types.

(Example) For continuous reception of messages from remote nodes 1 and 2.

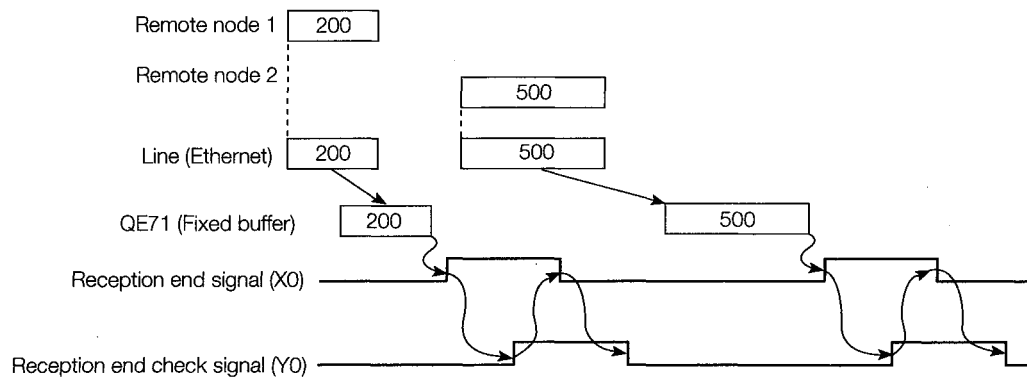

7.4.2 Program Creation Procedures

This section explains the data transmission and reception program creation procedures using fixed buffer without procedure.

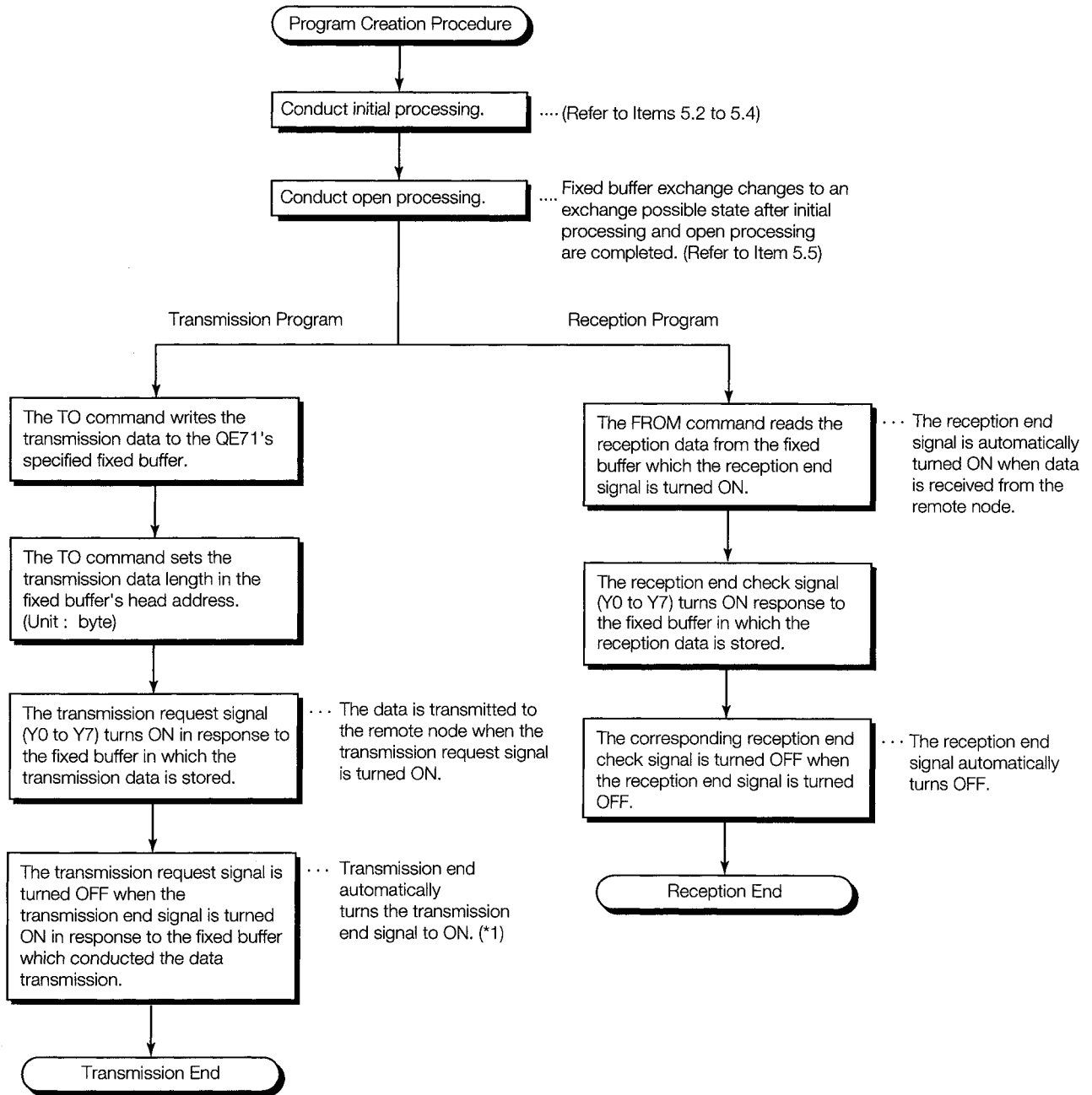

*1 When the transmission error detection signal is on, handle the exchange state storage areas information for individual connection (transmission error code) as specified in Chapter 17.

7.4.3 Example Fixed Buffer Exchange Program (Without Procedure)

This section explains the programming method for performing data exchange with a remote node using fixed buffer with procedure.

(Program Conditions)

- (1) All connection exchange parameters are set to those parameters specified in Item 5.5.5.
- (2) The fixed buffer transmission data is stored in D300 to D303.
- (3) The fixed buffer reception data is stored in D500 to D503.
- (4) The storage destination for the error code and end code are allotted as follows.
 D108 Transmission error code (when transmission)
 D109 Exchange end code
 D110 Transmission error code (when reception)

Fixed Buffer No.1 Transmission Program

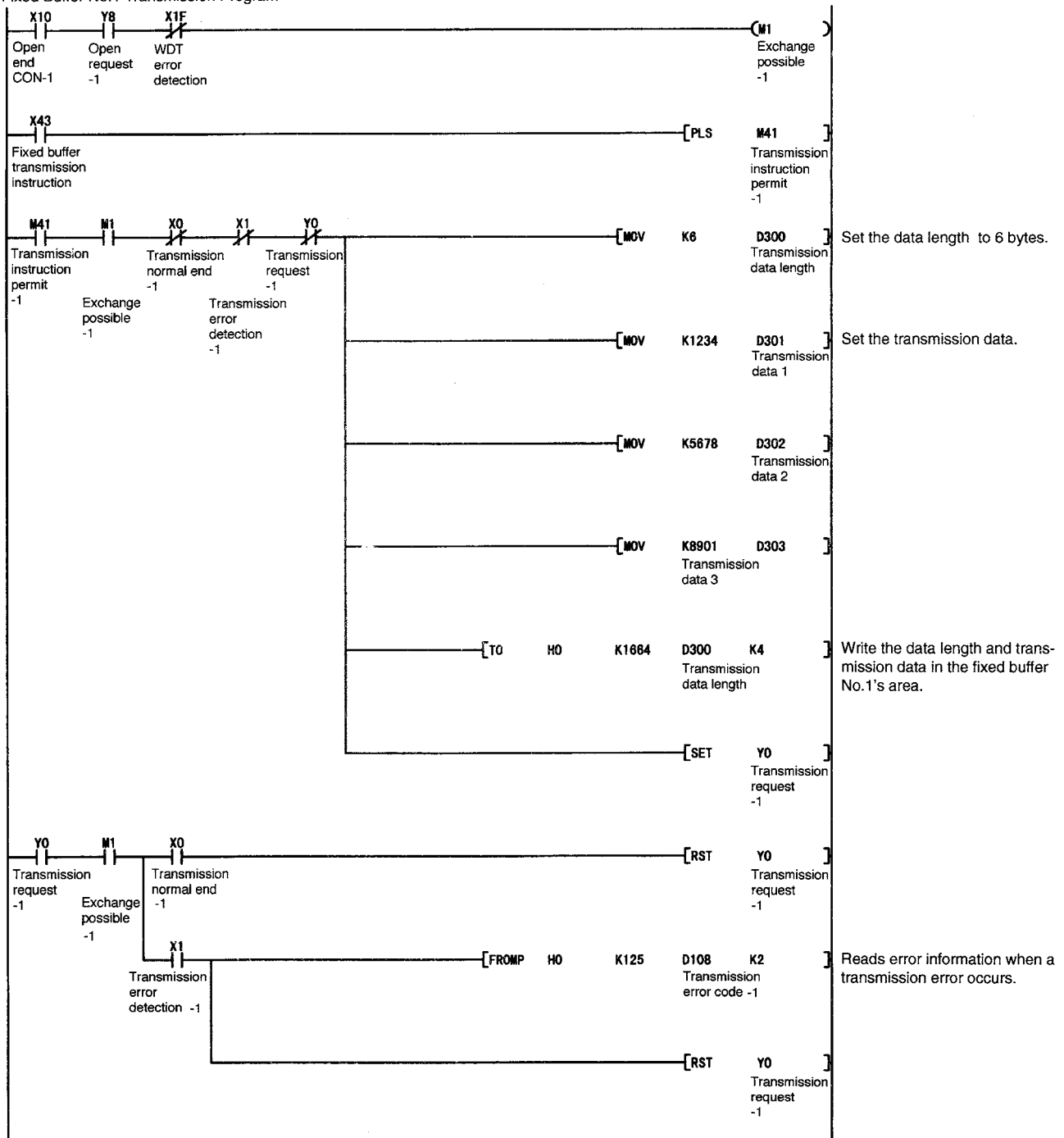

Fixed Buffer No.2 Reception Program

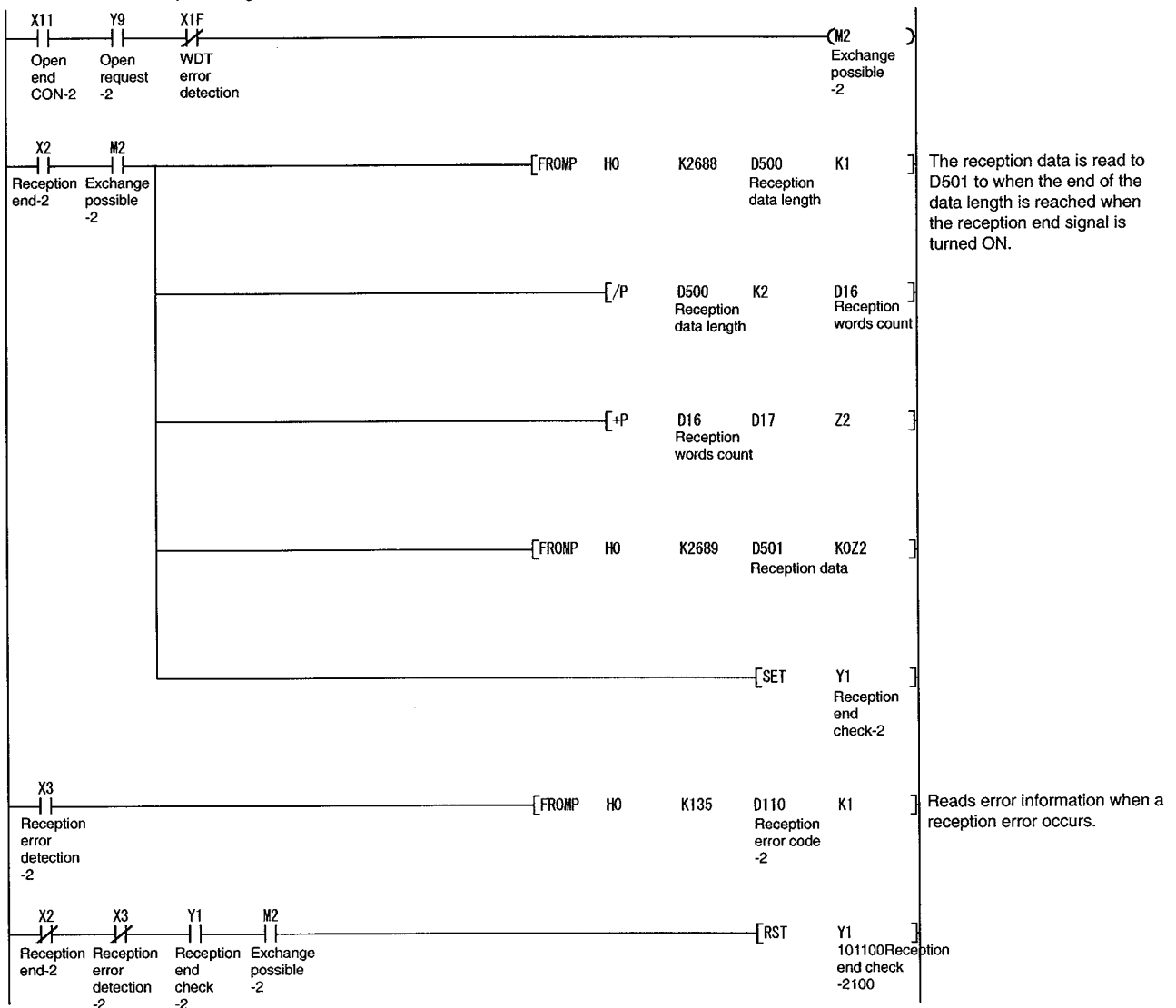

RANDOM ACCESS BUFFER EXCHANGE SECTION

The random access buffer exchange section explains the method for exchanging data between the remote node's external equipment and the PLC CPU using the Ethernet interface module's random access buffer.

Random access buffer exchange begins after the initial processing and open processing that connects the communication line as described in Chapter 5.

In addition, perform close processing and end processing when data exchange is completed for the subject communication line.

8. RANDOM ACCESS BUFFER EXCHANGE

This section explains the method for conducting exchange with remote nodes using the QE71's random access buffer.

8.1 Control Format

This section explains the exchange processing control format using the random access buffer.

For random access buffer exchange, data is written to the random access buffers and read from the random access buffer using commands (requests) from the remote nodes.

Writing to and reading from the QE71's random access buffer from the remote nodes is conducted asynchronously with the PLC CPU's sequence program.

- 1** The random access buffer is not fixed to the remote node to which exchange is done, but writing and reading can be freely conducted from any remote node (except QE71). Therefore, a common buffer area can be used for all nodes connected to the Ethernet.

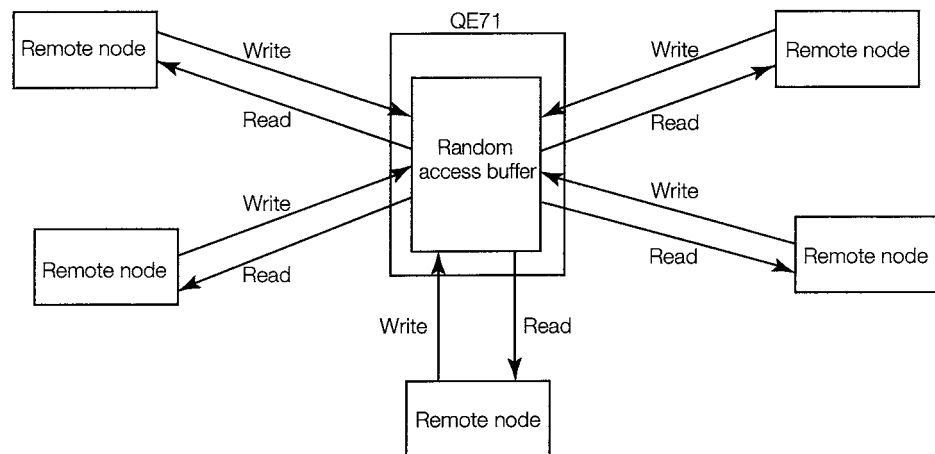

- 2** The data flow for exchange processing using the random access buffer is shown below.

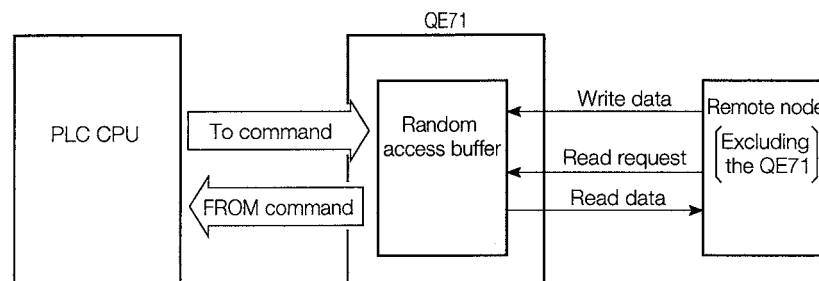

- 3** Random access buffer exchange can be conducted from the remote node shown below except for QE71 and E71. (Exchange cannot be done between QE71 and a QE71 or E71.)

- ① Remote nodes on the Ethernet to which the QE71 is connected.
- ② Remote nodes on the Ethernet that are connected using router relay functions (Refer to Chapter 12).

8.1.1 Control Method When There is a Read Request from a Remote Node

This section explains the control method when data is transmitted from the QE71 by a read request from a remote node.

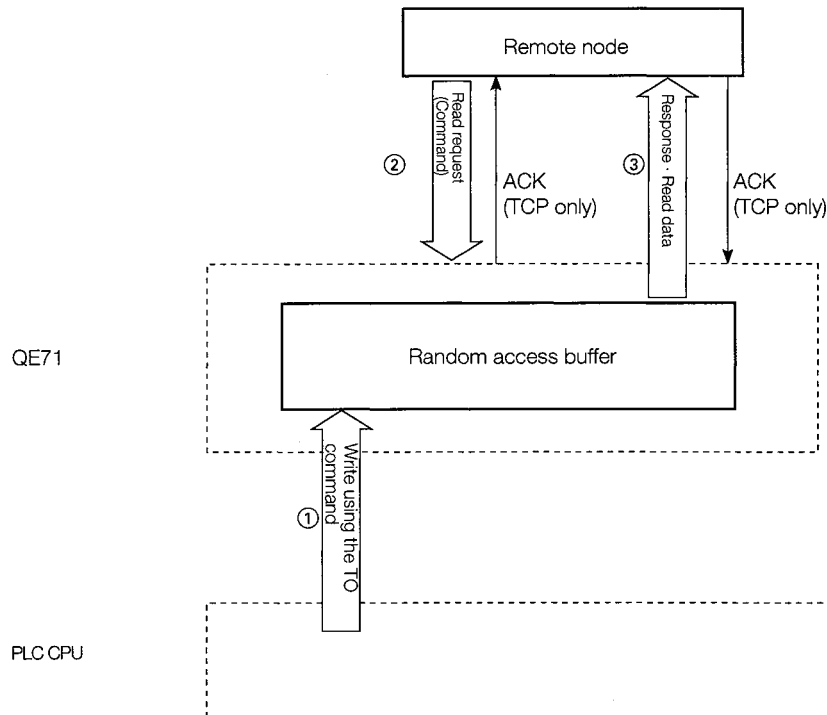

- ① Data is written to the QE71's random access buffer using the sequence program's TO command. In addition, data is written to the QE71's random access buffer from a remote node.
- ② A read request is transmitted from the remote node that will read the QE71's random access buffer contents to the QE71.
- ③ When a read request is received from a remote node, the QE71 will send the data written in the random access buffer to the node from which the request was received as a response.

Point

- (1) With random access buffer exchange, exchange can only be conducted with the remote node for which the QE71's open end signal (X10 to X17) is on.
- (2) Random access buffer exchange is conducted asynchronously with the sequence program. When synchronous exchange is required, conduct exchange by putting a free protocol between the partner remote node to which communication is being done and the PLC CPU.

8.1.2 Control Method When There is a Write Request from a Remote Node

This section explains the control mode when data is written by the remote node to the QE71's random access buffer.

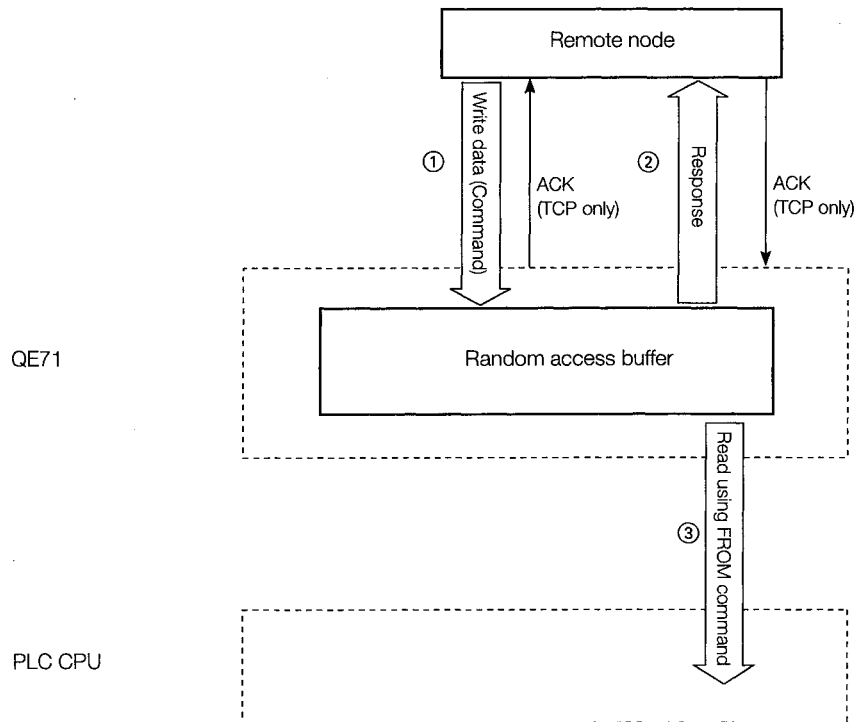

- ① Data is written from the remote node to the QE71's random access buffer.
- ② When the QE71 receives data from the remote node, a response is returned to the remote node that conducted the transmission.
- ③ The data received by the random access buffer using the sequence program's FROM command is read.

In addition, the data being received to the QE71's random access buffer can be read by the separate remote node.

Point

- (1) For random access buffer exchange, exchange can only be conducted with remote nodes for which the QE71's open end signal (X10 to X17) is on.
- (2) Random access buffer exchange is conducted asynchronously with the sequence program. When synchronous is required, conduct exchange by adding a free protocol between the partner remote node to which exchange is being conducted and the PLC CPU.

8.2 Data Format

This section explains the data format used when transmission and reception are conducted between the QE71 and a remote node.

The communication data is comprised of a header and application data as shown below.

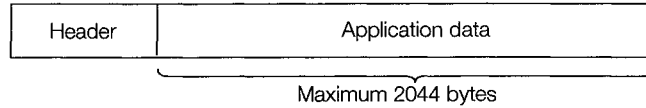

8.2.1 Header

The header is the header for TCP/IP or UDP/IP. For the QE71, the header is added by the QE71.

(Header size breakdown)

① For TCP/IP

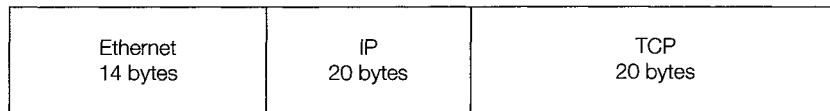

② For UDP/IP

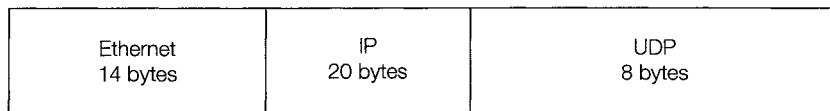

8.2.2 Application Data

As shown below, the application data can display the data code in binary or ASCII code.

The binary and ASCII settings are performed using the exchange condition setting switches (SW2: data code setting) of the QE71. (For details regarding the setting method, refer to Item 4.3.2.)

1 Format

(a) During command transmission and reception

① During binary code exchange

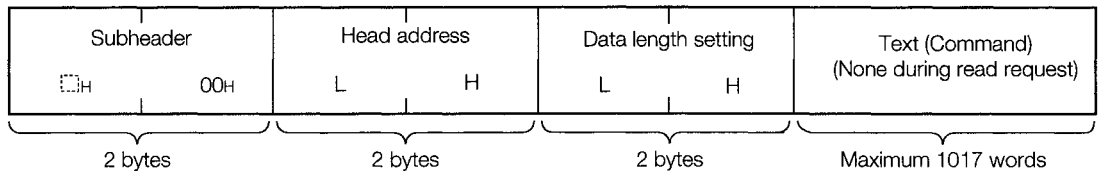

② During ASCII code exchange

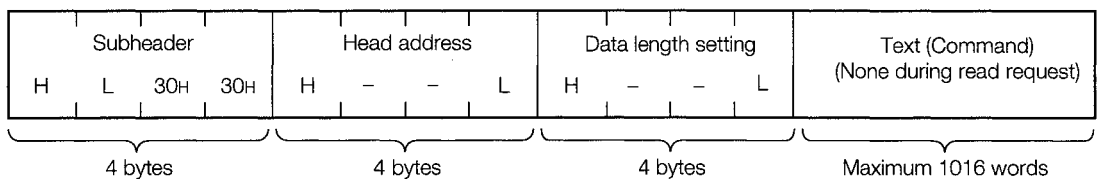

(b) During response transmission and reception (read)

① During binary code exchange

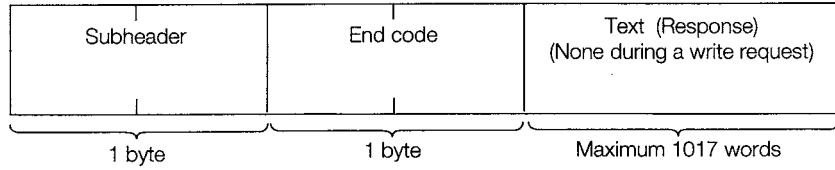

② During ASCII code exchange

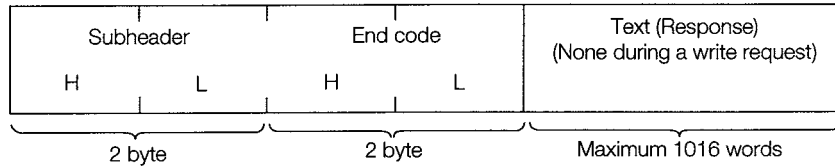

2 Subheader

The subheader format is shown below.

For the QE71, the QE71 automatically adds and deletes text, so user does not need to perform the settings.

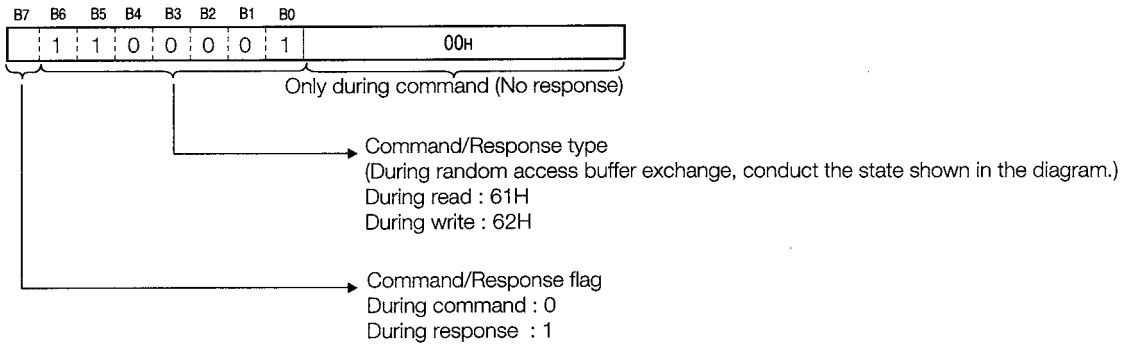

• During Read

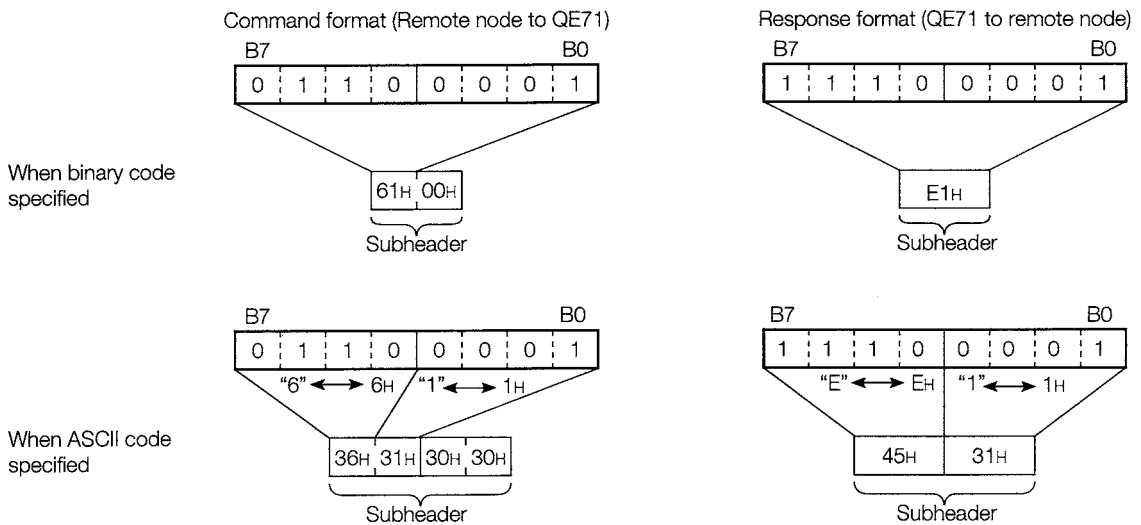

3 Head address

The head address (2680H to 3E7FH) of the random access buffer range that conducts the read and write of the data is shown as the theoretical address (0H to 17FFH....Refer to Item 8.3).

(a) During binary code exchange : The first address is indicated in binary values.

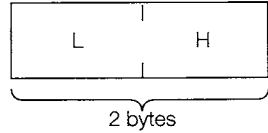

(b) During ASCII code exchange : Specifies the ASCII code when the head address is expressed in hexadecimal numbers.

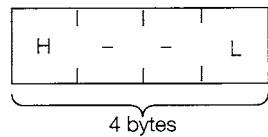

4 Data length setting

The number of words is expressed for the data read/write in the random access buffer range.

(a) During binary code exchange : The number of words (1 to 1017) is specified in binary value.

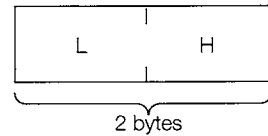

(b) During ASCII code exchange : Specifies the ASCII code when the number of words (1 to 508) is expressed in hexadecimal numbers.

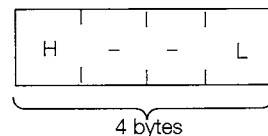

Point

(1) The read/write corresponding random access buffer's maximum number of words is 1017 when binary code is specified.

(2) The read/write corresponding random access buffer's size is a maximum of 508 words when ASCII code is specified. This is approximately one half that when the binary code is specified.

5

Text

Shows the write data and the read data for the random access buffer.

(a) During binary code exchange

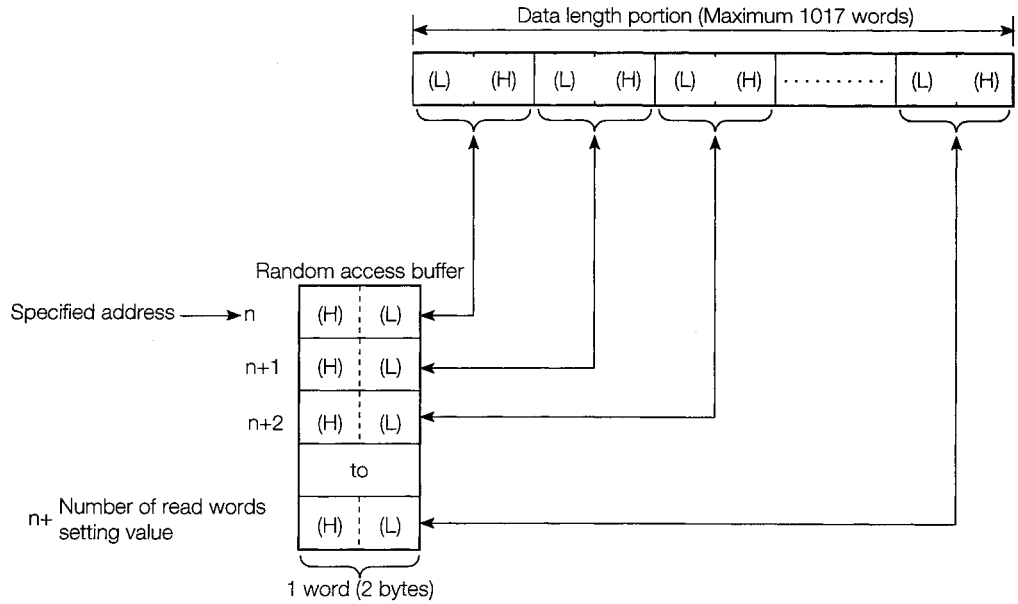

(b) During ASCII code exchange

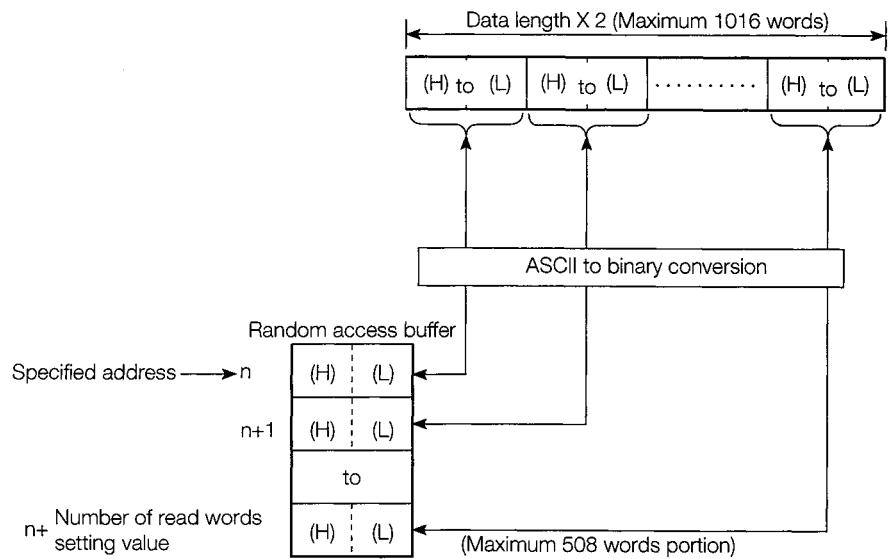

(Example)

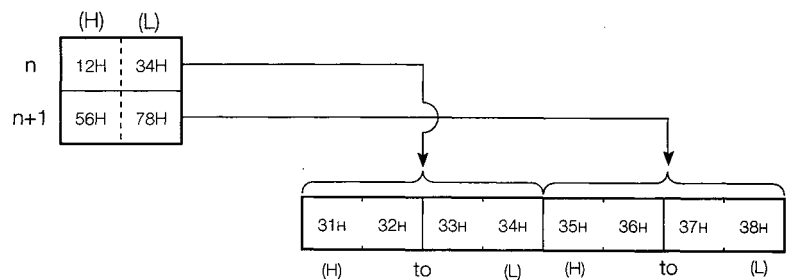

6

End code

Shows the end code added to the response during random access buffer exchange.

The end code is stored in the buffer memory exchange state storage area.

When binary code is specified		When ASCII code is specified	
00H	Normal end	30H30H	Normal end
50H	Command/Response type undefined error	35H30H	Command/Response type undefined error
51H	Head address defective	35H31H	Head address defective
52H	Number of data words defective	35H32H	Number of data words defective
	—————	35H34H	ASCII conversion error

(For details regarding error codes, refer to Chapter 17.)

8.2.3 Example Command and Response Format

Following is an example of the command and response format during random access buffer exchange.

1 Write to buffer using write request from remote node

When binary code specified

(a) Command format (Remote node to QE71)

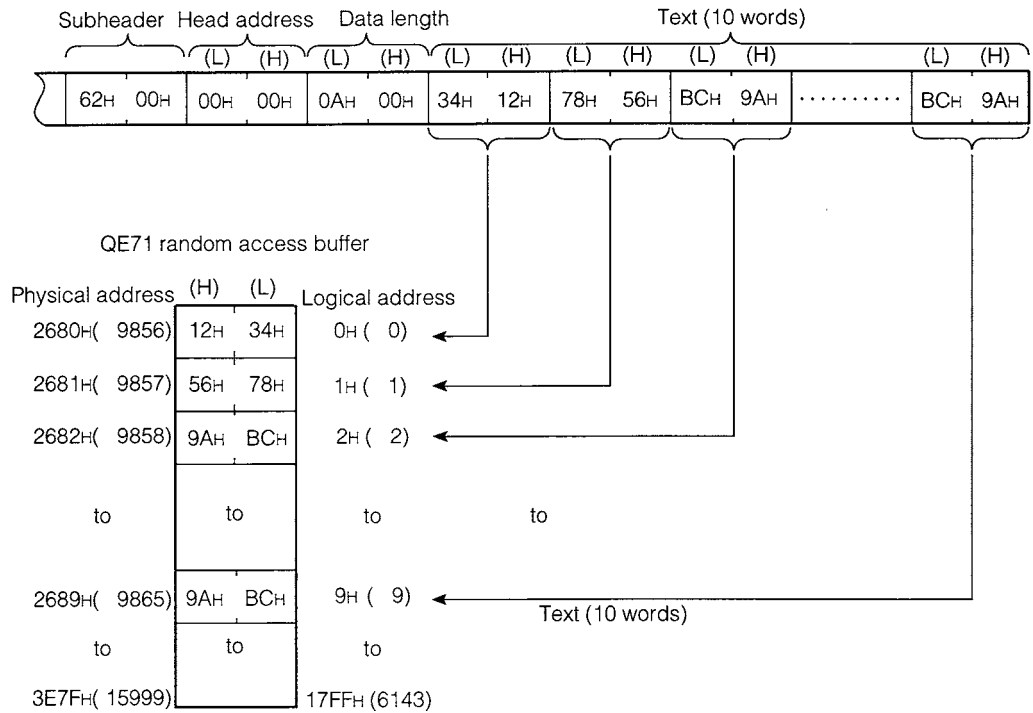

(b) Response format (QE71 to remote node)

Subheader	End code
E2H	00H

When ASCII code specified

(a) Command format (Remote node to QE71)

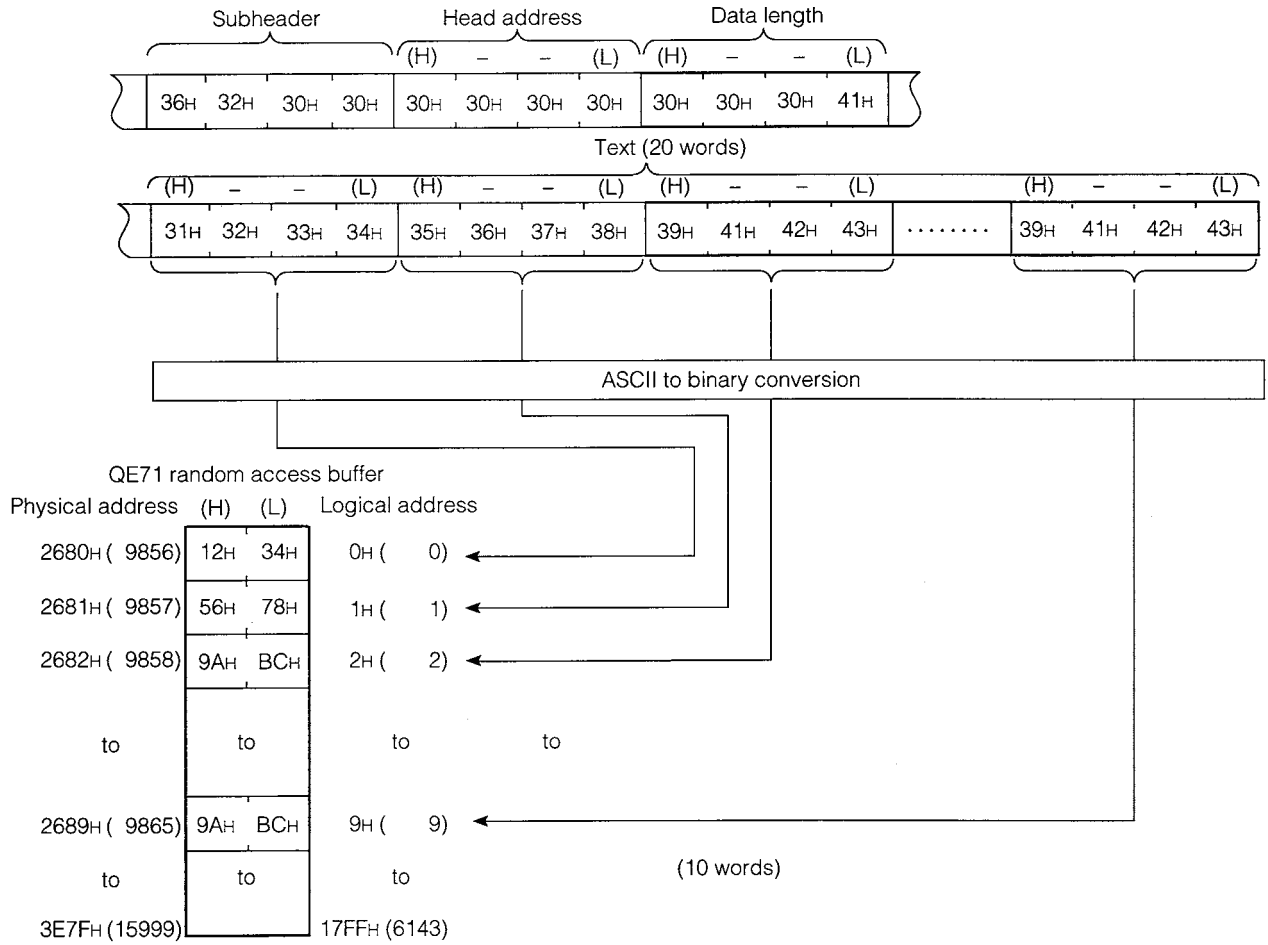

(b) Response format (QE71 to remote node)

Subheader	End code
45H 32H	30H 30H

2 Read from buffer using read request from remote node

When binary code specified

(a) Command format (Remote node to QE71)

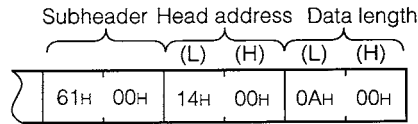

(b) Response format (QE71 to remote node)

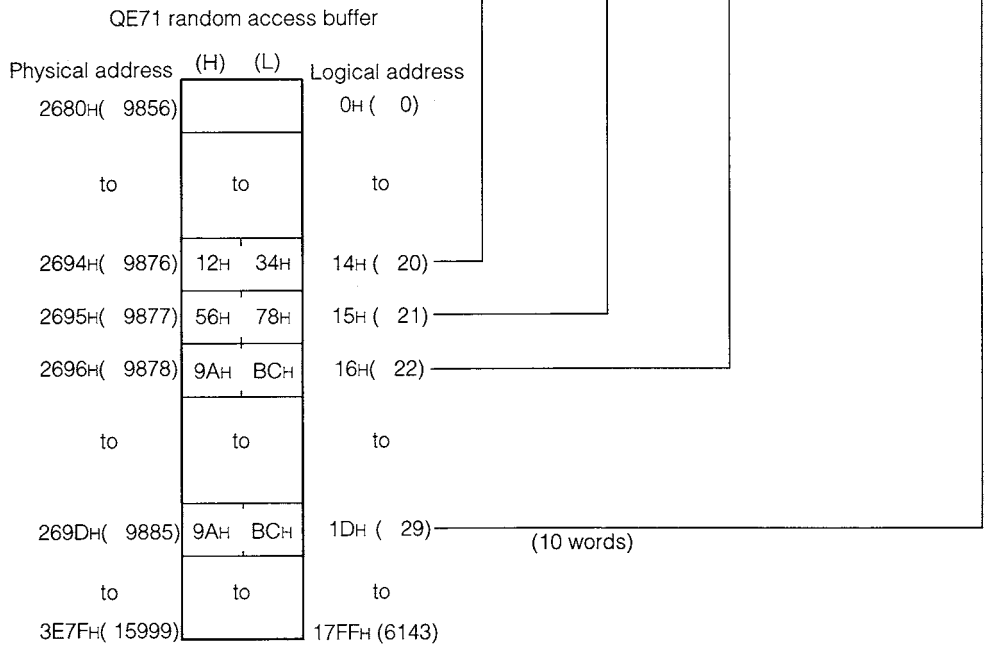
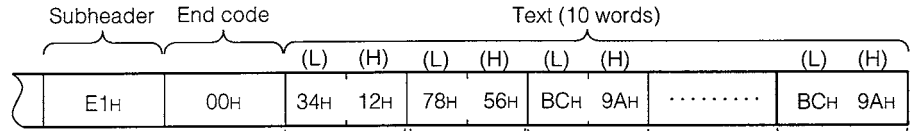

When ASCII code specified

(a) Command format (Remote node to QE71)

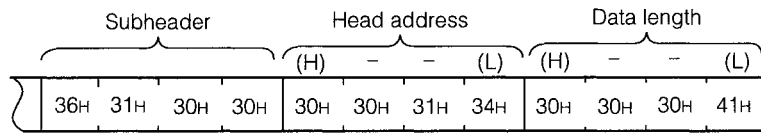

(b) Response format (QE71 to remote node)

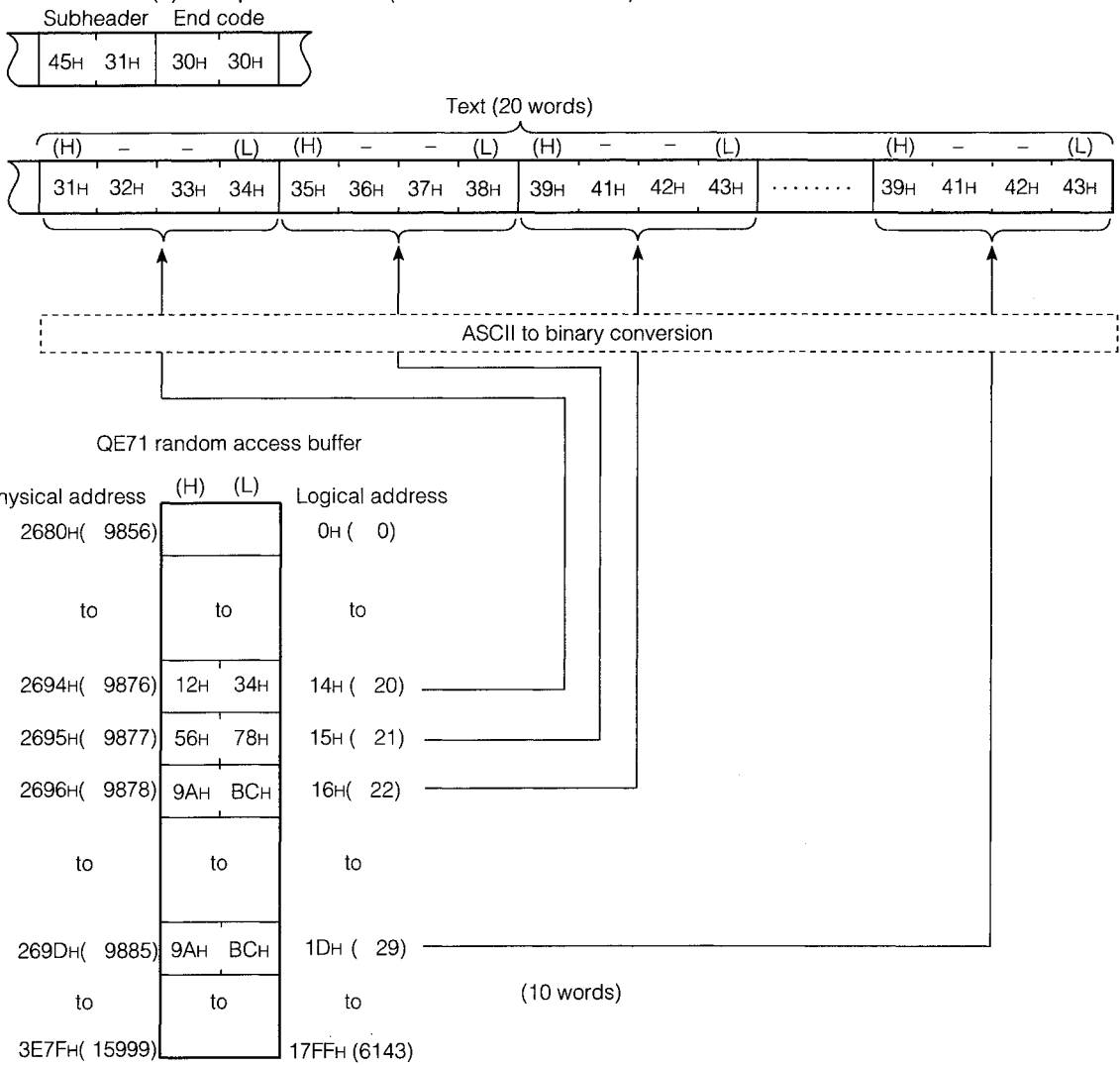

8.3 Random Access Buffer (Data Storage Area) Address

This section explains the head address for the QE71's random access buffer (no battery back up) specified during command for random access buffer exchange.

Following is shown the random access buffer's specified address.

For the random access buffer specified address, the address specified by the remote node and the address specified by the sequence program's FROM/TO commands differ, so caution is required.

Physical address : Address specified by the sequence program's FROM/TO commands.

Logical address : The address specified in the head address item during command during random access buffer exchange.

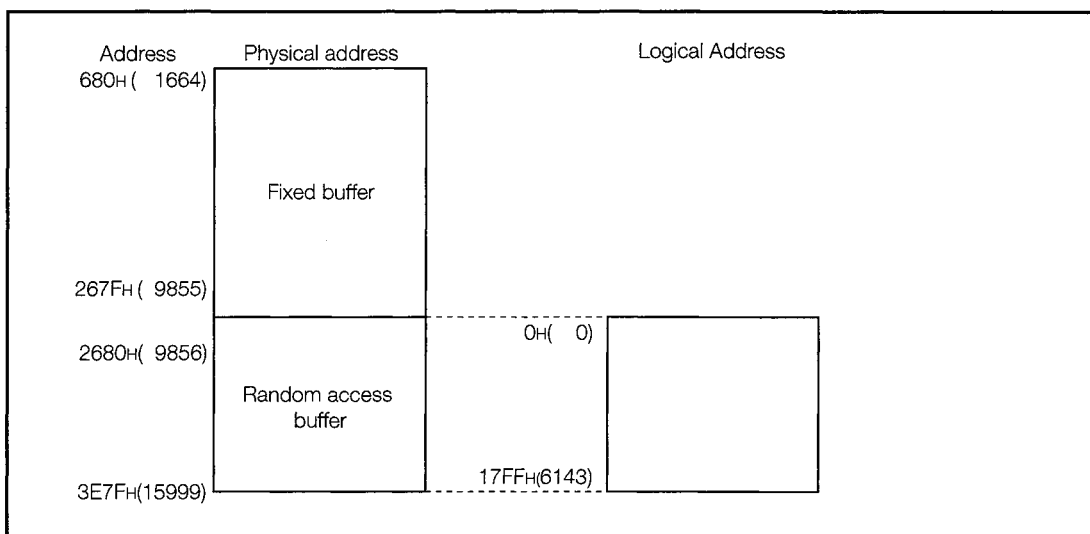

8.4 Programming

This section explains the programming for conducting exchange between the QE71 and a remote node using the random access buffer.

8.4.1 Program Creation Precautions

- (1) Exchange with a remote node using the random access buffer is conducted asynchronously with the PLC CPU program.

When synchronous exchange is required, conduct exchange by adding a free protocol between the partner remote node to which exchange will be conducted and the PLC CPU.

- (2) For the random access buffer, the address specified by the remote node and the address specified by the sequence program's FROM/TO commands differ, so caution is required. (For details, refer to Item 8.3.)
- (3) For command transmission, the next command should be sent after the completion of data communication (such as after the reception of a response) for the transmission of the previous command.

8.4.2 Program Creation Procedure

This section explains about the random access buffer exchange procedure.

As shown below, there are three exchange methods that can be used for random access buffer exchange.

- ① Remote node (A) or (B) reads the data written into the QE71's random access buffer by remote node (A).
- ② Remote nodes (A) and (B) read the data written in the QE71's random access buffer by the sequence program.
- ③ The sequence program reads the data written in the QE71's random access buffer by remote node (A) or (B).

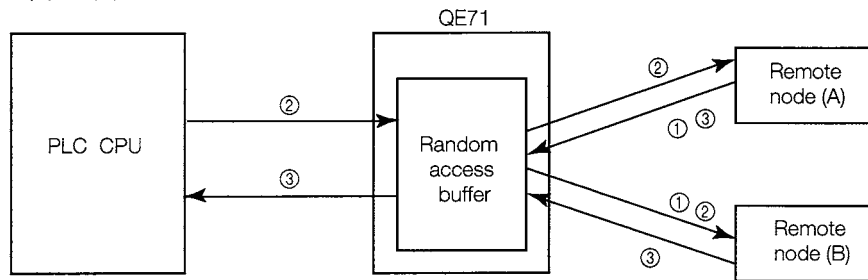

Following is an explanation of the exchange procedure for exchange methods the three described above.

1 Exchange procedure where remote (B) reads the data written by remote node (A)

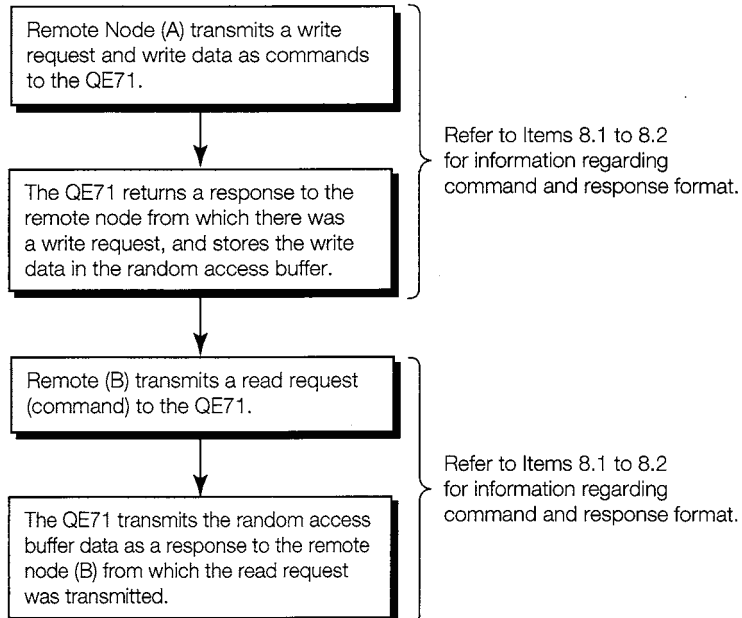

2 Exchange procedure when the remote node reads the data written by the sequence program

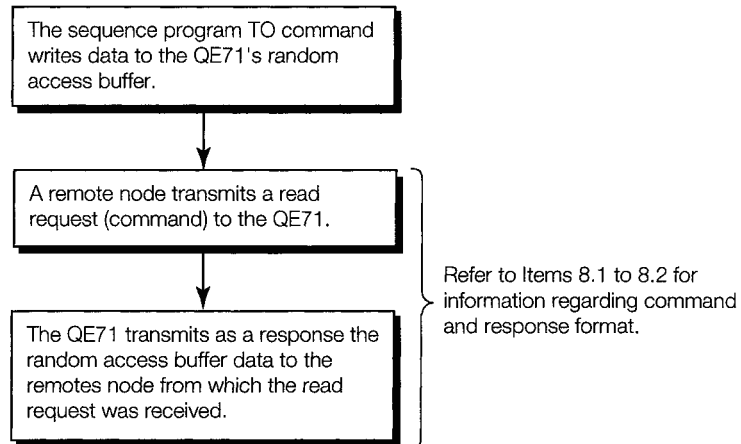

3 Exchange procedure when the data written from a remote node is read by the sequence program

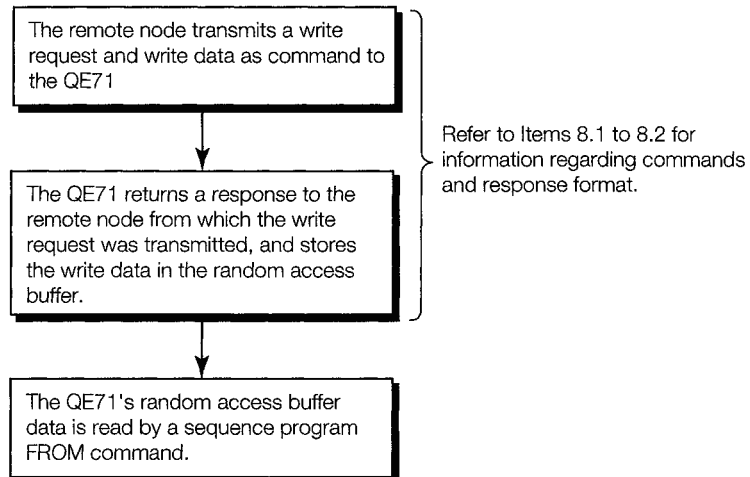

Remarks

With random access buffer exchange, a handshake cannot be conducted using the QE71's I/O signal.

READING/WRITING DATA IN THE PLC CPU SECTION

The reading and writing data in the PLC CPU section describes the method for reading and writing device memory and files in the PLC CPU by the remote node's external devices via the Ethernet interface module, and the method for conducting remote control of the PLC CPU.

Reading and writing data in the PLC CPU is done regardless of the PLC CPU's RUN/STOP state when the automatic open UDP port is used.

When the automatic open UDP port is not used, conduct reading and writing data in the PLC CPU after connecting a communication line using initial processing and open processing as described in Chapter 5. In addition, conduct close processing and end processing when data exchange on the corresponding communication line is ended.

When reading and writing data inside the PLC CPU, common items are explained in Chapter 9, so read this chapter first.

When reading and writing QE71 commands, read Chapters 9 and 10.

When reading and writing E71 commands, read Chapter 9 of this manual and then the following manual.

- For A Ethernet Interface Module User's Manual Chapter 10

9. READING/WRITING DATA IN THE PLC CPU EXCHANGE

This section explains the control method, command list, and data exchange precautions when reading and writing PLC device and file data, etc., via the QE71 from a remote node.

9.1 Control Format

This section explains the control method when reading and writing data in the PLC CPU.

1 Reading and writing data in the PLC CPU can be performed regardless of the QE71's I/O signal on/off state and the existence of the data exchange sequence program.

2 When writing to the PLC CPU from a remote node, the write approval/prohibition during PLC CPU RUN, can be selected using the exchange condition setting switch (SW7: CPU exchange timing setting) of the QE71.

Exchange timing setting (Refer to Item 4.3.2)

SW7 OFF : Writing from a remote node is not possible during PLC CPU RUN.

ON : Writing from the remote node is possible during both PLC CPU RUN/STOP.

3 Data can be read from and written to the QnACPU and special function module by the remote node by transmitting the QE71 commands or E71 commands described in Item 9.2 to the QE71. In addition, it is also possible to read and write data to the remote station PLC CPU and special functions modules on the MELSECNET.

Point

- (1) When writing to the special functions module installed in the remote I/O stations in the data link system or network system from the remote node, the exchange condition setting switch (SW7: exchange timing setting) must be set to on. (The remote I/O station will change to the normal RUN state. You cannot switch between the RUN and STOP.)
- (2) Refer to each system reference manual for details regarding the access for remote station PLC on data link system or network system.
- (3) By using the MELSECNET/10 relay exchange function, exchange with PLC CPUs at remote Ethernet via MELSECNET/10 are possible.
Refer to Chapter 15 for detail.
- (4) By using the Q4ARCPU with added functions, the range of stations that can be accessed from MELSOFT products via Ethernet connection has been widened.
Referring to Item 4.8 **7**, check whether access to the Q4ARCPU/remote stations via the Q4ARCPU is possible.
- (5) To access the QCPU of a remote station or a MELSECNET/H remote I/O station, refer to Item 2.4.

9.1.1 Exchanging with the PLC CPU Installed in the QE71

- 1 The control method for reading and writing data in the PLC CPU installed in the QE71 is as follows.

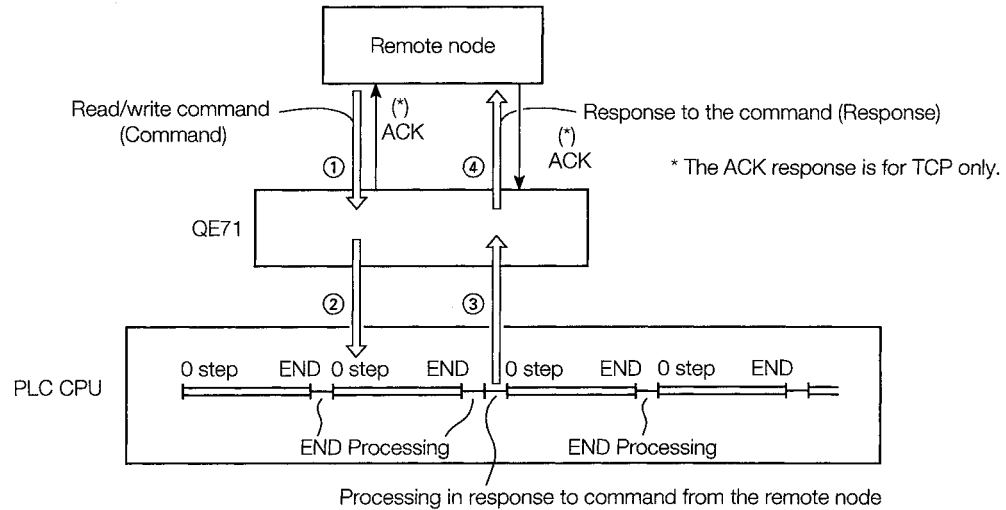

- ① The remote node transmits to the QE71 a command to read/write data in the PLC CPU.
- ② When the QE71 receives the command from the remote node, it requests the read/write of data in the PLC CPU in accordance with the contents of the command.
- ③ When the sequence program's END command is executed, the PLC CPU follows the request from the QE71 and conducts the data read/write and then transmits the processing results to the QE71.
- ④ When the QE71 receives the processing results from the PLC CPU, it sends a response that includes the processing results to the remote node from which the request originated.

Point

- (1) When read/write from the remote node is conducted during PLC CPU RUN, the processing time in response to the command from the remote node and the sequence program's scan time could become longer so caution is required.
- (2) Refer to Item 9.3 for information regarding the required number of scans when a module, such as a remote QE71, for the same QnACPU or an access request is received at the same time from a GPP.

9.1.2 Exchanging with the PLC CPU in the Network System

- 1** When reading and writing data in the PLC CPU, reading and writing to the remote station PLC on the MELSECNET/10 can be done via the PLC CPU installed in the QE71 within the network system's specification range.

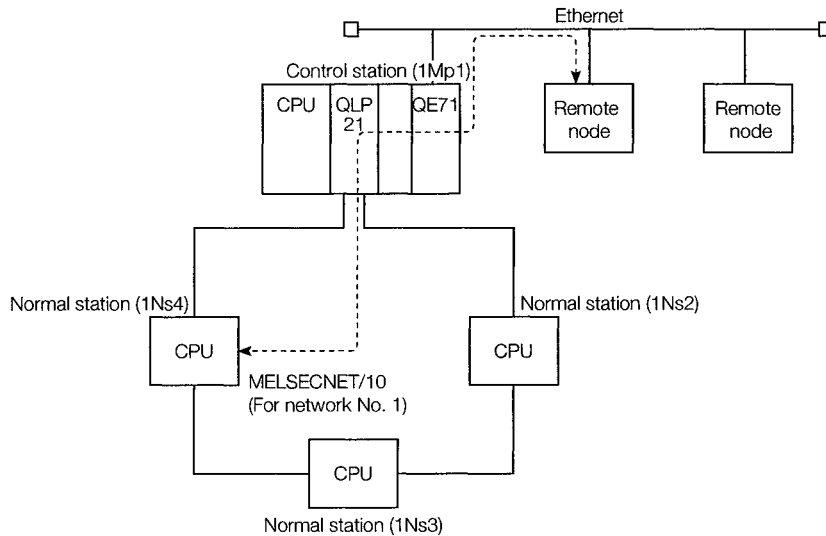

- 2** The PLC that conducts reading and writing is specified using the following data items in the command message.

- (a) When using QE71 commands
Specifies the network No. (00H to EFH, FEH) and PLC No. (FFH, 00H to 40H, 7DH). (Refer to Item 10.1)
- (b) When using E71 commands
Specifies the PLC No. (FFH, 00H to 40H).

	Remote node access station	PLC No. specified by remote node
1	QE71 installed station (Local Station)	FFH
2	Network control station between PLC on the MELSECNET/10 (When the QE71 is installed in the write normal station in the network between PLC)	0H (0)
	Remote I/O net's master station on the MELSECNET/10 (When the QE71 is installed and remote I/O net remote station)	
3	Station on the MELSECNET/10 (Except for 1 and 2 above)	01H to 40H (1 to 64) (Access station No.)

Point

- (1) When conducting remote access station by E71 command, set the following parameters in the QE71 installed station's PLC CPU using the GPP.
 - Setting for "valid module when accessing remote stations"... Set in the number of modules setting, and set the module to go through when accessing remote station.
- (2) When multiple network modules are installed for the same network No. in the QE71 installation station, remote station access is done via the network modules installed in the base module's slot of the newest No. when the network No. is specified.
- (3) Refer to Item 9.3 for information regarding the required number of scans when a module, such as a remote QE71, for the same QnACPU or an access request is received at the same time from a GPP.

3 Of the remote stations in the network system those for which exchange with a PLC is possible are shown below. The exchange possible PLC vary depending on the stations installed with the QE71.

(Meaning of station symbols shown in the diagram)

- Network system (MELSECNET/10)

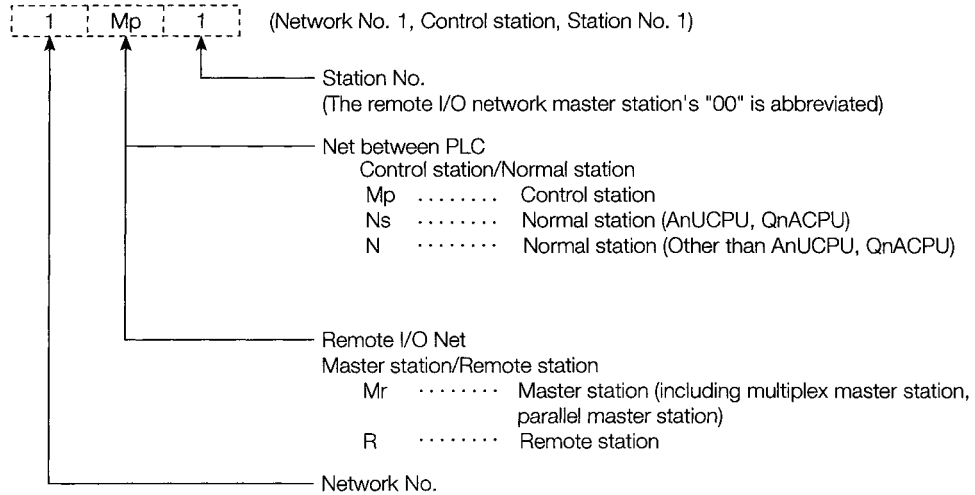

(a) When the QE71 installed station is the net between PLC control station/normal station, and when the remote I/O net master station

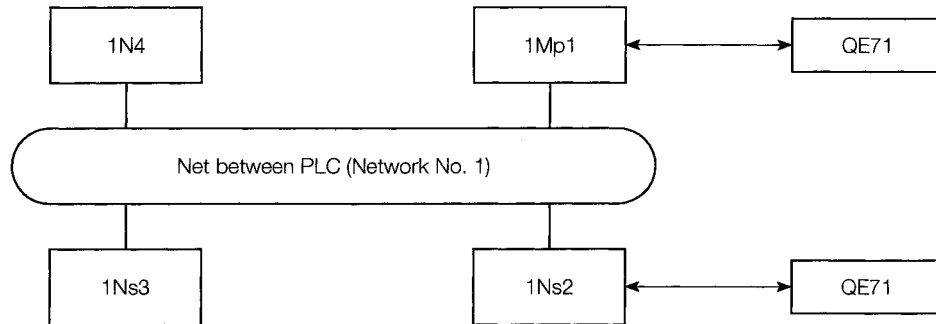

(b) When the QE71 installed station is the remote I/O net's remote station

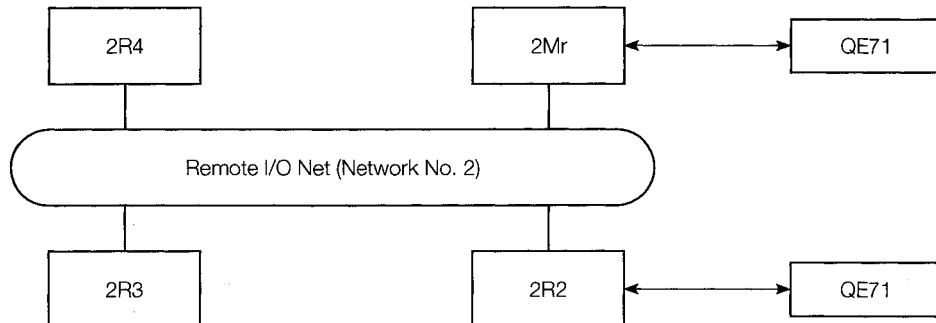

① Network No. and PLC No. When QE71 commands are used

When the QE71 is installed in the control station (1Mp1)	Exchange possible PLC and corresponding item specification values (Hexadecimal numbers)				
	Local station	1Mp1	1Ns2	1Ns3	1N4
Network No.	00	—	01		
PLC No.	FF	—	02	03	04

When the QE71 is installed in the normal station (1Ns2)	Exchange possible PLC and corresponding item specification values (Hexadecimal numbers)				
	Local station	1Mp1	1Ns2	1Ns3	1N4
Network No.	00	01	—	01	
PLC No.	FF	7D	—	03	04

When the QE71 is installed in the master station (2Mr)	Exchange possible PLC and corresponding item specification values (Hexadecimal numbers)				
	Local station	2Mr	2R2	2R3	2R4
Network No.	00	—	02		
PLC No.	FF	—	02 ⁿ¹	03 ⁿ¹	04 ⁿ¹

When the QE71 is installed in the remote station (2R2)	Exchange possible PLC and corresponding item specification values (Hexadecimal numbers)				
	Local station	2Mr	2R2	2R3	2R4
Network No.	00	02	—	x	
PLC No.	FF ⁿ¹	7D	—	x	

② PLC No. When E71 Commands are used

PLC installed with the QE71	Exchange possible PLC and PLC No. item specification values (Hexadecimal numbers)								
	Local station	1Mp	1Ns2	1Ns3	1N4	2Mr	2R2	2R3	2R4
1Mp1	FF	—	02	03	04	x			
1Ns2	FF	01	—	03	04	x			
2Mr	FF	x				—	02 ⁿ¹	03 ⁿ¹	04 ⁿ¹
2R2	FF ⁿ¹	x				00	—	x	

n Access to all devices is possible by setting the corresponding PLC No.

n¹ Access to the special function module buffer memory is possible by setting the corresponding PLC No.

x Access is not possible.

4 Transmission when via network system

(a) The transmission time (T1) when data is transmitted to a PLC on a network system in which a QE71 is not installed is shown below.

① For net between PLC

- Transmission time (T1) = $\frac{\text{Transmission delay time} + \text{QE71 installed station 1 scan time}}{*1} \times \frac{(n + 1)}{*2 *3}$
- *1 Refer to the network system reference manual for an explanation of the transmission delay time.
- *2
 - When initial exchange is conducted for the corresponding station when the power is turned on and after the CPU is reset.
 - When exchange is conducted to the station except the 16 stations most recently exchange with. } n = 6
 - When exchange is conducted the second time when the number of exchange stations is under 16. } n = 1
 - When exchange is conducted the second time to the first 16 stations.
- *3 When the "CPU exchange timing setting" of the QE71 exchange condition setting switch SW7 is off (write prohibited), it is added only when data is written from remote node.
- Reason for transmission time (T1) delay

When commands that require two scans (device write, etc. when the exchange condition setting switch (SW7: exchange timing setting) is off, etc.) are executed, then the value is twice that calculated using the above formula.

Refer to Item 9.3 2 for information regarding the necessary number of scans when request access to the same QnACPU is made at the same time by a remote QE71, GPP, etc.
- Increase the CPU monitoring timer's monitoring time from the remote station when device read is conducted via MELSECNET/10.
- * For details regarding network systems, refer to the for QnA network system reference manuals.

(Example) When a QE71 is installed in the station on the MELSECNET/10 (net between PLC) and the device memory for a remote system on the same MELSECNET/10 is read. (Second exchange time when the number of exchange stations is under 16)

- ST : Transmission scan time 120ms • α T : Transmission link refresh time 10ms
- SR : Receive scan time 100ms • α R : Receive link refresh time 5ms
- LS : Link scan 30ms
- Number of simultaneous transient requests : 3 • Maximum number of times for transient : 2

$$\begin{aligned}
 \text{Transmission Time (T1)} &= \{ \underset{\text{(ST)}}{120} \times 2 + \underset{\text{(}\alpha\text{T)}}{10} \times 2 + \underset{\text{(LS)}}{30} \times 6 + \underset{\text{(SR)}}{100} \times 2 + \underset{\text{(}\alpha\text{R)}}{5} \times 2 \\
 &+ \left[\frac{3 \text{ (Number of simultaneous transient requests)}}{2 \text{ (Maximum number of transient times)}} - 1 \right] \times \underset{\text{(LS)}}{30} \times 2 + \underset{\text{(ST)}}{120} \} \times 1 = 890\text{ms} \\
 &\quad \text{Adjustment value (Decimal round off)}
 \end{aligned}$$

② For remote I/O net

- Transmission Time (T1) = $\frac{\text{Transmission delay time} + 1 \text{ link scan time}}{\text{*1}} \times \frac{(n + 1)}{\text{*2 *3}}$

*1 Please refer to the explanation of transmission delay time in the network system reference manual.

*2

- When exchange is conducted for the first time to the subject station after link is begun. } n = 6
- When conducting exchange to a station except the latest 16 stations to which exchange was conducted. } n = 6
- When conducting exchange for the second time when the number of exchange stations is under 16. } n = 1
- When conducting exchange for the second time to the latest 16 stations in which exchange was conducted. } n = 1

*3 When the "CPU exchange timing setting" of the QE71 exchange condition setting switch SW7 is off (write prohibited), it is added only when data is written from remote node.

- Reason for transmission time (T1) delay
 When commands that require two scans (device write, etc. when the exchange condition setting switch (SW7: exchange timing setting) is off, etc.) are executed, then the value is twice that calculated using the above formula.
 Refer to Item 9.3 2 for information regarding the necessary number of scans when request access to the same QnACPU is made at the same time by a remote QE71, GPP, etc.
- Increase the CPU monitoring timer's monitoring time from the remote station when reading from devices via MELSECNET/10.

* For details regarding network systems, refer to the for QnA network system reference manuals.

(Example) When a QE71 is installed in a station on an MELSECNET/10 (remote I/O net) and read from a remote station device memory is conducted on the same MELSECNET/10.

(Second exchange time when the number of exchange stations is under 16)

- Sm : Master station sequence scan time 120ms
- α m : Master station link refresh time 10ms
- α r : Remote I/O station link refresh time 2ms
- LS : Link scan time 30ms

Because the above (Sm) > (LS) the formula is as follows. (When there is one master station)

$$\text{Transmission Time (T1)} = \{ (\text{Sm}) + (\alpha m) \times 3 + (\text{LS}) \} \times 1 = 420\text{ms}$$

Point

There will be an appropriate delay corresponding to the conditions during data transmission to a PLC in which a QE71 is not installed on the MELSECNET/10.

The transmission delay time for exchange with the PLC can be reduced by using the QE71 installed station (PLC No.FFH) only and using the MELSECNET/10 data link (LB, LW) for exchange with remote station PLC.

9.1.3 Exchanging with the PLC CPU in the Data Link System

1 When reading and writing in the PLC CPU, reading and writing can be done to the remote station PLC in the MELSECNET(II) and MELSECNET/B via the PLC CPU in which a QE71 is installed within the data link system specification range.

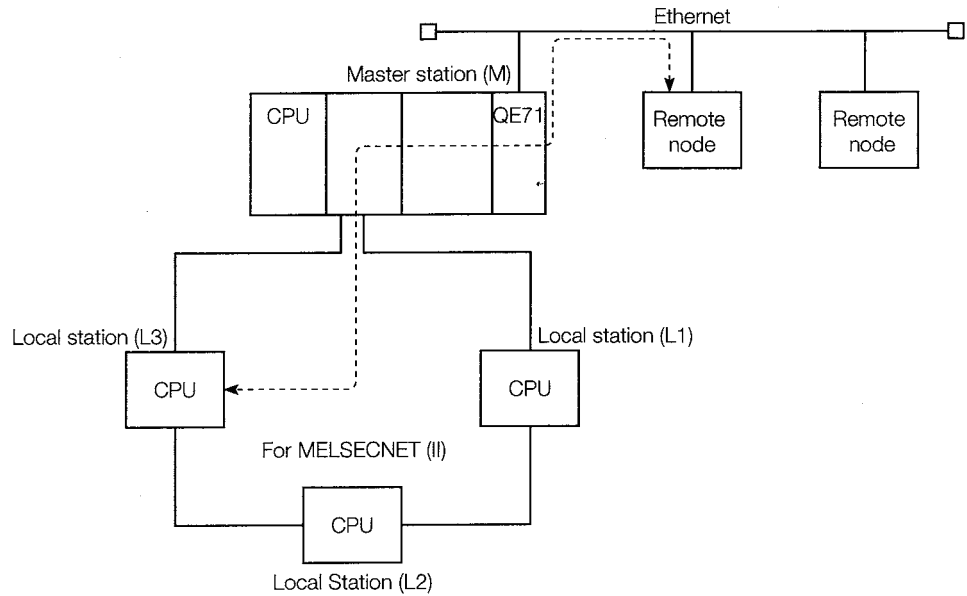

2 The PLC to perform the read/write is specified by the data items in the following message.

- (a) When QE71 commands are used
Specifies the network No. (00H) and PLC No. (FFH, 00H to 40H). (Refer to Item 10.1)
- (b) When E71 commands are used
Specifies the PLC No. (FF, 00H to 40H).

	Remote node access station	PLC No. specified by the remote node
1	QE71 installed station (Local station)	FFH
2	Master station on the MELSECNET(II) (Excluding 1 above)	00H
3	Local station/Remote station on the MELSECNET(II) (Except 1 and 2 above)	01H to 40H (1 to 64) (Access station's station No.)
4	Station on the MELSECNET/B	(Same as 2 and 3 above)

Point

- (1) When conducting remote access station by E71 command, set the following parameters in the QE71 installed station's PLC CPU using the GPP.
 - Setting for "valid module when accessing remote stations"Set in the number of modules setting, and set the module to go through when accessing remote stations.
- (2) Refer to Item 9.3 for information regarding the required number of scans when a module, such as a remote QE71, for the same QnA CPU or an access request is received at the same time from a GPP.

3 The following shows the exchange possible PLC of the remote stations in the data link system.

The exchange possible stations vary according to the stations with QE71 installed.

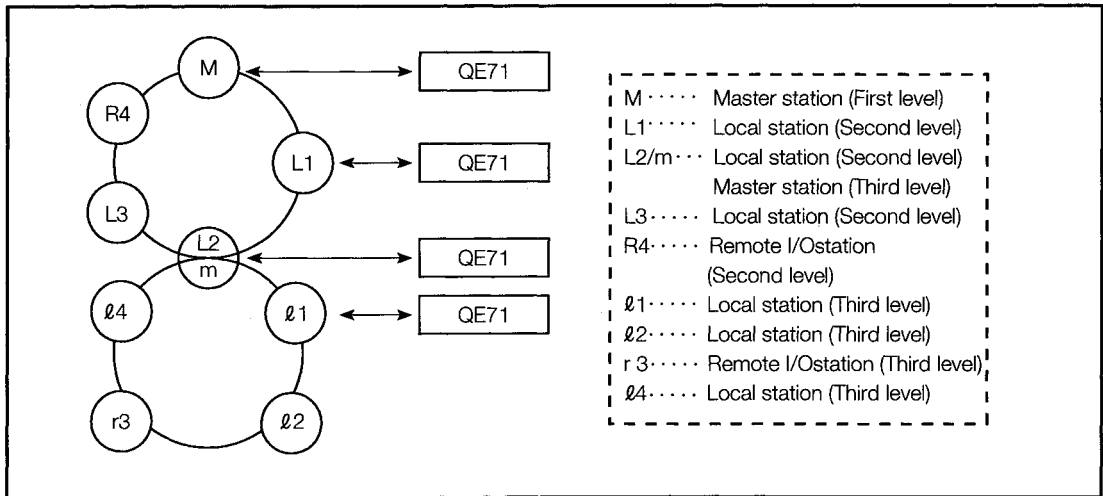

(a) Network No. and PLC No. when QE71 commands are used

When the QE71 is installed in the master station (M)	Exchange possible PLC and corresponding item specification values (Hexadecimal numbers)									
	Local station	M	L1	L2/m	L3	R4	l 1	l 2	r3	l 4
Network No.	00	—	00					x		
PLC No.	FF	—	01	02	03	04 ⁿ¹			x	

When the QE71 is installed in the local station (L1)	Exchange possible PLC and corresponding item specification values (Hexadecimal numbers)									
	Local station	M	L1	L2/m	L3	R4	l 1	l 2	r3	l 4
Network No.	00	—					x			
PLC No.	FF	00	—				x			

When the QE71 is installed in a local station and master station (L2/m)	Exchange possible PLC and corresponding item specification values (Hexadecimal numbers)									
	Local station	M	L1	L2/m	L3	R4	l 1	l 2	r3	l 4
Network No.	00		x	—	x		00			
PLC No.	FF	00	x	—	x		01	02	03 ⁿ¹	04

When the QE71 is installed in a local station (l 1)	Exchange possible PLC and corresponding item specification values (Hexadecimal numbers)									
	Local station	M	L1	L2/m	L3	R4	l 1	l 2	r3	l 4
Network No.	00	x	00		x		—		x	
PLC No.	FF	x	00		x		—		x	

n All devices can be accessed by specifying the corresponding PLC's No.
 nⁿ¹ ... The special function module's buffer memory can be accessed by specifying the corresponding PLC's No.
 x Access not possible

(b) PLC No. when using E71 commands

Same as for access possible stations. Specify the same PLC No. as specified for the No. in (a) above.

Point
 Exchange cannot be done with A0J2CPUP23/R23 and A0J2P25/R25.

(4) Communication time when done via data link system

(a) The following shows the transmission time (T1) when data transmission is conducted to a PLC in which a QE71 is not installed on the data link system.

- Local station

$$\text{Transmission Time (T1)} = \frac{\text{Transmission delay time A} + \text{QE71 installed station 1 scan time}}{\text{*1}} \times \frac{\text{(n+1)}}{\text{*2 *3}}$$
- Remote I/O station

$$\text{Transmission time (T1)} = \frac{\text{Transmission delay time B} + \text{Master station 1 scan time}}{\text{*1}} \times \frac{\text{(n+1)}}{\text{*2 *3}}$$

*1 Refer to the explanation on the corresponding data link system transmission delay time in the data link system reference manual.

Transmission delay time A : Refer to the symbol column for the LRDP command processing time

Transmission delay time B : Refer to the symbol column for the RFRP command processing time

*2

- When exchange is conducted for the first time to the subject station when the power is turned on or when the CPU reset has been conducted. } n = 3
- When exchange is conducted with a station other than the latest 10 stations to which exchange has been conducted. }
- When exchange is conducted for the second time when the number of exchange stations is under 10. } n = 1
- When exchange is conducted for the second time to the latest 10 stations to which exchange has been conducted. }

*3 When the "CPU exchange timing setting" of the QE71 exchange condition setting switch SW7 is off (write prohibited), it is added only when data is written from remote node.

- Reason for transmission time (T1) delay
 When commands that require two scans (device write, etc. when the exchange condition setting switch (SW7: exchange timing setting) is off, etc.) are executed, then the value is twice that calculated using the above formula.
 Refer to Item 9.3 2 for information regarding the necessary number of scans when request access to the same QnACPU is made at the same time by a remote QE71, GPP, etc.
- Lengthen the CPU monitoring timer's monitoring time from the remote station when device read is conducted via the data link system.

* Refer to the data link system reference manual for details regarding data links.

(Example) When the QE71 is installed in the MELSECNET (II) master station, and the local station's device memory is read.

(Conditions $L < LS < M$, $M : 80\text{ms}$ $\alpha 1 : 10\text{ms}$)

$$\text{Transmission Time (T1)} = (M \times 4 + \alpha 1 \times 4 + M) \times 1 = (80 \times 4 + 10 \times 4 + 80) \times 1 = 440$$

T1 is 880ms.

- M : MELSECNET master station scan time
- $\alpha 1$: MELSECNET master station link refresh time
- LS : Link scan time
- L : MELSECNET local station's scan time

Point

Depending on conditions, a considerable delay can occur in data transmission to the PLC in which a QE71 is not installed on the MELSECNET.

The transmission delay time can be reduced by using only the QE71 installed station (PLC No. FFH) for exchange with the PLC, and by using a data link (B, W) for exchange with a remote station PLC CPU.

9.1.4 Exchanging with the PLC CPU in Mixed Systems

1 When reading and writing the data in the PLC CPU, reading and writing data to remote station PLC is possible by going through multiple network systems with PLC in which QE71s are installed within the network system specification range.

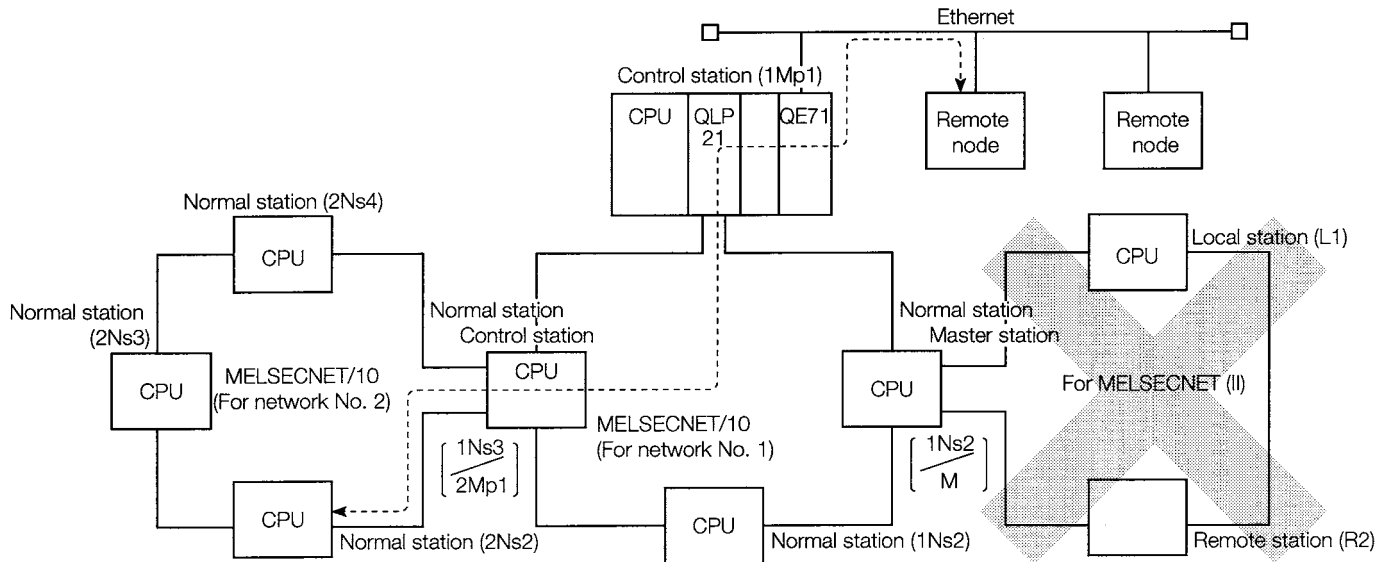

2 When using the QE71 commands, reading and writing can be conducted to remote station PLC on a different network system (net between PLC, remote I/O net) via multiple network systems.

In this case, reading and writing can be conducted to remote station PLC via network system control station, normal station (station that becomes subcontrol station), and master station's relays. The possible number of relays is a maximum of seven stations.

When using E71 commands, reading and writing to remote station PLC via multiple network systems is not possible.

3 Reading and writing cannot be done to the following remote station PLC even if QE71 commands or E71 commands are used.

- ① Remote station PLC on data link systems via network systems.
- ② Remote station PLC on network systems via data link systems.

4 When using QE71 commands, the PLC that performs reading and writing via the network systems, has the network No. and the message set to (01H to EFH, FEH) and the PLC No. set to (FFH, 01H to 40H, 7DH).

(Refer to Item 10.1)

Point

- (1) When conducting remote access station by E71 command, set the following parameters in the QE71 installed station's PLC CPU using the GPP.
 - Setting for "valid module when accessing remote stations"Set in the number of modules setting, and set the module to go through when accessing remote stations.
- (2) When multiple network modules are installed for the same network No. in the QE71 installation station, remote station access is done via the network modules installed in the base module's slot of the newest No. when the network No. is specified .

5 The following shows the exchange possible PLC in remote stations in the mixed system. Exchange possible PLC differ according to the stations in which QE71s are installed. MELSECNET/10 parameters for accessing remote stations, such as the routing parameters, must be set in the related station. (The routing parameters make it possible to access other network stations through multiple station relays.)

(Meaning of station symbols shown in the diagram)

- Network system (MELSECNET/10)

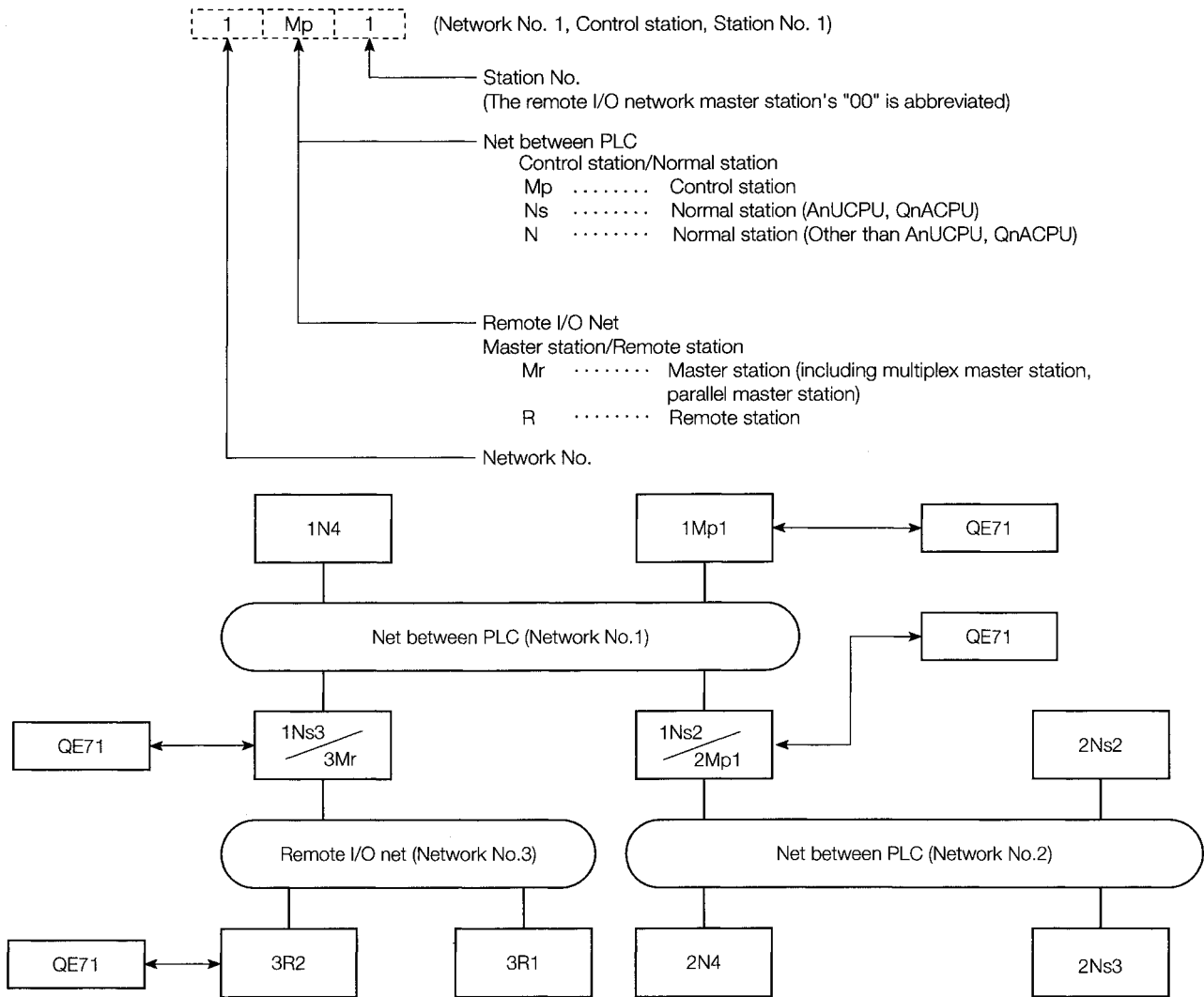

① Network No. and PLC No. when QE71 commands are used

When the QE71 is installed in the control station (1Mp1)	Exchange possible PLC and corresponding item specification values (Hexadecimal numbers)									
	Local station	1Mp1	1Ns2 2Mp1	1Ns3 3Mr	1N4	2Ns2	2Ns3	2N4	3R1	3R2
Network No.	00	—	01		02			03		
PLC No.	FF	—	02	03	04	02	03	04	01 ⁿ¹	02 ⁿ¹

When the QE71 is installed in the normal station and control station (1Ns2, 2Mp1)	Exchange possible PLC and corresponding item specification values (Hexadecimal numbers)									
	Local station	1Mp1	1Ns2 2Mp1	1Ns3 3Mr	1N4	2Ns2	2Ns3	2N4	3R1	3R2
Network No.	00	01	—	01		02			03	
PLC No.	FF	7D	—	03	04	02	03	04	01 ⁿ¹	02 ⁿ¹

When the QE71 is installed in the normal station and master station (1Ns3, 3Mr)	Exchange possible PLC and corresponding item specification values (Hexadecimal numbers)									
	Local station	1Mp1	1Ns2 2Mp1	1Ns3 3Mr	1N4	2Ns2	2Ns3	2N4	3R1	3R2
Network No.	00	01		—	01	02			03	
PLC No.	FF	7D	02	—	04	02	03	04	01 ⁿ¹	02 ⁿ¹

When the QE71 is installed in the remote station (3R2)	Exchange possible PLC and corresponding item specification values (Hexadecimal numbers)									
	Local station	1Mp1	1Ns2 2Mp1	1Ns3 3Mr	1N4	2Ns2	2Ns3	2N4	3R1	3R2
Network No.	00	01		03	01	02			x	—
PLC No.	FF ⁿ¹	01	02	7D	04	02	03	04	x	—

② PLC No. when the E71 commands are used.

When the QE71 is installed in the PLC	Exchange possible PLC and corresponding item specification values (Hexadecimal numbers)									
	Local station	1Mp1	1Ns2 2Mp1	1Ns3 3Mr	1N4	2Ns2	2Ns3	2N4	3R1	3R2
1Mp1	FF	—	02	03	04	x				
1Ns2/2Mp1	FF	00	—	03	04	02	03	04		x
1Ns3/3Mr	FF	00	x	—	04	x			01 ⁿ¹	02 ⁿ¹
3R2	FF ⁿ¹	x		00	x				x	—

n All devices can be accessed by setting the corresponding PLC's No.
nⁿ¹ ... The special functions module buffer memory can be accessed by setting the corresponding PLC's No.
x Access not possible

6**Transmission time when exchanging over multiple network systems**

The transmission time when transmitting data to PLC in which a QE71 is not installed on a network system, is the total of all MELSECNET transmission times.

Point

The data transmission time can become considerably long for PLC in which QE71s are not installed on MELSECNET/10.

The transmission delay time can be reduced by only exchanging with the QE71 installation station (PLC No.FFH) or exchange with a PLC CPU, and by communicating with the MELSECNET/10 data link (LB, LW) for exchanging with remote station PLC.

9.2 List of Commands

This section explains the commands and functions used to read and write data in the PLC CPU from remote nodes.

9.2.1 List of QE71 Commands and Functions

This section explains the QE71 commands, functions, and their processing.

QE71 commands can be used for QnACPU, A series PLC CPUs, remote stations, and QE71s, and can access device memories, files, and buffer memories.

The □ spaces in the table (subcommands) differ depending on the specified device and command functions used. Please refer to the suitable explanation items in Chapter 10 for information regarding the □ areas.

Of these commands, the device memory access commands can be used in PLC CPUs other than QnACPU.

Functions		Command (Subcommand) * For ASCII code exchange: Specified by each ASCII code. During binary code exchange: Each set with hexadecimal number values.	Description of processing	Number of points processed performed for 1 exchange		
				Access ^{*7} station-1	Access ^{*8} station-2	
Device memory	Batch read	Bit unit	0 4 0 1 (0 0 □ 1)	Bit devices (X, Y, M etc.) are read in 1 point units.	1792/3584 points	256 points
		Word unit	0 4 0 1 (0 0 □ 0)	Bit devices (X, Y, M, etc.) are read in 16 point units.	480 words (7680 points)	32 words (512 points)
				Word devices (D, R, T, C, etc.) are read in 1 point units.	480 points	64 points
	Batch write	Bit unit	1 4 0 1 (0 0 □ 1)	Bit devices (X, Y, M, etc.) are written to in 1 point units.	1792/3584 points	160 points
		Word unit	1 4 0 1 (0 0 □ 0)	Bit devices (X, Y, M, etc.) are written to in 16 point units.	480 words (7680 points)	10 words (160 points)
				Word devices (D, R, T, C, etc.) are written to in 1 point units.	480 points	64 points
	Random read	Word unit	0 4 0 3 (0 0 □ 0)	Bit devices (X, Y, M, etc.) are read in 16 and 32 point units and the device No. are randomly set. However, devices other than QnACPU are only written in 16 points.	96 points	10 words (160 points)
				Word devices (D, R, T, C, etc.) are read in 1 and 2 point units and the devices and device No. are set randomly. However, other than QnACPU are only read in 1 point units.		10 points
	Test (Random write)	Bit unit	1 4 0 2 (0 0 □ 1)	Bit devices (X, Y, M, etc.) are set and reset in 1 point units and the devices and device No. are randomly set.	94 points	20 points
		Word unit	1 4 0 2 (0 0 □ 0)	Bit devices (X, Y, M, etc.) are set and reset in 16 point and 32 point units, and the devices and device No. are randomly set. However, those other than QnACPU are only set in 16 point units.	960 points	10 words (160 points)
				Word devices (D, R, T, etc.) are written in 1 and 2 point units and the devices and device No. are randomly set. However, those other than QnACPU are only written in 1 point units.		10 points
	Monitor data registration	Word unit	0 8 0 1 (0 0 □ 0)	The monitoring bit devices (X, Y, M, C etc.) are registered in 16 point and 32 point units. However, those other than the QnACPU are registered in 16 bit units. ^{*2}	96 points	20 words (320 points)
				The monitoring word devices (D, R, T, C, etc.) are registered in 1 and 2 point units. However, those other than the QnACPU are only read in 1 point units.		20 points
	Monitor	Word unit	0 8 0 2 (0 0 0 0)	Monitors the devices that perform monitor data registration.	(Number of registered points)	
Multiple block batch read	Word unit	0 4 0 6 (0 0 □ 0)	Making n-points of word device and bit device (one point is 16 bits) as one block, read multiple blocks specified randomly.	480 points	(Not possible)	
Multiple block batch write	Word unit	1 4 0 6 (0 0 □ 0)	Making n-points of word device and bit device (one point is 16 bits) as one block, write multiple blocks specified randomly.	480 points	(Not possible)	
Drive memory	Memory usage condition read	0 2 0 5 (0 0 0 0)	Reads the drive cluster usage state.	(256 clusters)		
	Memory optimization	1 2 0 7 (0 0 0 0)	Performs drive memory optimization to increase the continuously open areas. (File storage position optimization)	(For 1 station)	(Not possible)	

Corresponding PLC CPUs that can execute commands														PLC CPU state *1			Reference Item	
A0J2	A0J2 H	A1, A1N	An(N) (Other than left), AnS	A3H, A3M	A2C, A2G, A2CJ	AnA	AnU	AJ72 P25/ R25	QLP 25 LP25 / QBR 15 BR15	Q2A Q2AS Q2ASH (S1)	Q3A	Q4A Q4AR	A73	A7L MS-F	During STOP	During RUN		
																Write possible setting		Write not possible setting
	x			○					x		○			○				Item 10.2.1
	x			○					x		○			○	○	○	○	Item 10.2.2
	x			○					○		○			○				Item 10.2.3
	x			○					x		○	*4		○				Item 10.2.1
	x			○					x		○	*4		○	○	○	x	Item 10.2.4
	x			○					○		○	*4		○				Item 10.2.5
	x			x					x		○			x				Item 10.2.1
	x			x					x		○			x				Item 10.2.6
	x			○					x		○	*4		○				Item 10.2.1
	x			○					x		○	*4		○			x	Item 10.2.7
	x			○					○		○	*4		○				Item 10.2.8
				x					x		○			x				Item 10.2.1
				x					○		○			x				Item 10.2.9
				x					○		○			x	○	○	○	Item 10.2.1
				x					x		○	*9		x	○	○	○	Item 10.2.10
				x					x		○	*9		x	○	○	x	Item 10.2.10
				x					x		○	*4		x	○	○	○	Item 10.5
				x					x		○	*5		x	○	x	x	Item 10.5

Functions		Command (Subcommand) * For ASCII code exchange: Specified by each ASCII code. During binary code exchange: Each set with hexadecimal number values.	Description of processing	Number of points processed performed for 1 exchange		
				*7 Access station-1	*8 Access station-2	
File	File information list read	No titles	0 2 0 1 (0 0 0 0)	Reads the file lists (file name, date of last edit, file size).	(36 items)	(Not possible)
		With titles	0 2 0 2 (0 0 0 0)	Reads the file lists (files with titles, file name, date of last edit, file size).	(16 items)	
		File No. usage state	0 2 0 4 (0 0 0 0)	Reads the file No. usage state.	(256 items)	
	File information change	Final edit date change	1 2 0 4 (0 0 0 0)	Changes the file's final edit date.	(1 item)	
		File name and size change	1 2 0 4 (0 0 0 1)	Changes the file name and file size	(1 item)	
		Batch change	1 2 0 4 (0 0 0 2)	Changes the file name, file size, and final edit date.	(1 item)	
	File search		0 2 0 3 (0 0 0 0)	Reads whether the specified file exists, file No., and file size.	(1 item)	
	File description read		0 2 0 6 (0 0 0 0)	Reads the file description.	960 bytes	
	New registration (File name registration)		1 2 0 2 (0 0 0 0)	Preserves the specified file name in the file area.	(1 item)	
	File description write	Free data	1 2 0 3 (0 0 0 0)	Writes the specified data (n bytes) in the file.	960 bytes	
		Same data	1 2 0 3 (0 0 0 1)	Writes the specified data (1 word) for the n bytes in the file.	(File size portion)	
	File lock registration/cancellation		0 8 0 8 (0 0 0 □)	Registers a file lock that prevents changes in content from other than the specified file access. Also deletes registration.	(1 item)	
	File copy		1 2 0 6 (0 0 0 0)	Writes the contents of an existing file into a newly registered file. (Copies)	480 bytes	
File delete		1 2 0 5 (0 0 0 0)	Deletes a file.	(1 item)		
PLC CPU	Remote RUN		1 0 0 1 (0 0 0 0)	Request remote RUN to the PLC CPU.	(For 1 station)	
	Remote STOP		1 0 0 2 (0 0 0 0)	Request remote STOP to the PLC CPU.	(For 1 station)	
	Remote PAUSE		1 0 0 3 (0 0 0 0)	Request remote PAUSE to the PLC CPU.	(For 1 station)	
	Remote latch clear		1 0 0 5 (0 0 0 0)	Request a remote latch clear to the PLC CPU when the PLC CPU is in the STOP state.	(For 1 station)	
	Remote RESET		1 0 0 6 (0 0 0 0)	Request a remote RESET to the PLC CPU to cancel the PLC CPU's error stop state.	(For 1 station)	

Corresponding PLC CPUs that can execute commands														PLC CPU state *1			Reference Item	
A0J2	A0J2 H	A1, A1N	An(N) (Other than left), AnS	A3H, A3M	A2C, A2G, A2CJ	AnA	AnU	AJ72 P25/R25	QLP 25 LP25 / QBR 15 BR15	Q2A Q2AS Q2ASH (S1)	Q3A	Q4A Q4AR	A73	A7L MS-F	During STOP	During RUN		
																Write possible setting		Write not possible setting
				x							○			x				Item 10.6.1 to Item 10.6.4
				x							○			x	○	○	○	
				x							○			x	○	○	○	
				x							○	*4 *6		x				Item 10.6.1 to Item 10.6.3 Item 10.6.5
				x							○	*4 *6		x	○	○	x	
				x							○	*4 *6		x	○	○	x	
				x							○			x	○	○	○	Item 10.6.1 to Item 10.6.3 Item 10.6.6
				x							○	*6		x	○	○	○	Item 10.6.1 to Item 10.6.3 Item 10.6.7
				x							○	*4 *6		x	○	○	x	Item 10.6.1 to Item 10.6.3 Item 10.6.8
				x							○	*4 *6		x	○	○	x	Item 10.6.1 to Item 10.6.3 Item 10.6.9
				x							○			x	○	○	○	Item 10.6.1 to Item 10.6.3 Item 10.6.10
				x							○	*4 *6		x	○	○	○	Item 10.6.1 to Item 10.6.3 Item 10.6.11
				x							○	*4 *6		x	○	○	x	Item 10.6.1 to Item 10.6.3 Item 10.6.12
				x							○	*4		x	○	○	○	Item 10.4
				x							○	*4		x	○	○	○	
				x							○	*4		x	○	○	○	
				x							○	*4		x	○	x	x	

Functions		Command (Subcommand) * For ASCII code exchange: Specified by each ASCII code. During binary code exchange: Each set with hexadecimal number values.	Description of processing		Number of points processed performed for 1 exchange	
					^{*7} Access station-1	^{*8} Access station-2
EEPROM ^{*3}	Registered data read	0 6 1 1 (0 0 0 0)	Reads the registered data from the QE71.		960 bytes	(Not possible)
	Data registration	1 6 1 1 (0 0 0 0)	Registers the data exchange setting values (parameters) in the QE71. (Write)			
Special function module	Batch read	0 6 0 1 (0 0 0 0)	Reads the buffer memory data of special function module.		960 bytes (Refer to Item 10.3 for access station)	
	Batch write	1 6 0 1 (0 0 0 0)	Writes the buffer memory data of special function module.			
Buffer memory ^{*3}	Batch read	0 6 1 3 (0 0 0 0)	Reads the QE71's buffer memory data.	Can be used for exchanging data between the PLC CPU and external device.	480 words (960 bytes)	
	Batch write	1 6 1 3 (0 0 0 0)	Writes the QE71's buffer memory data.			
LED Off ^{*3}		1 6 1 7 (0 0 0 □)	Turns off the display error LED.		(For 1 station)	
Loopback test ^{*3}		0 6 1 9 (0 0 0 0)	Checks whether the data transmission between the QE71 and the external device was conducted normally. (Used to check the connection state and the exchange functions)		960 bytes (Exchange possible only for connected stations)	

*1 Use the QE71's exchange condition setting switch (SW7: exchange timing setting) to set whether it is possible to write to the PLC CPU during RUN.

SW7 = ON Write possible during RUN (Enable)

SW7 = OFF Write not possible during RUN (Disable)

*2 For other than A3HCPU, AnA, AnU, QnACPU, 2 points worth of points are processed for each point for device X (input).

$$\begin{aligned}
 &(\text{Number of specified points} \times 2) \\
 &+ \text{number of other device set points} \leq \text{number of points processed per one exchange.}
 \end{aligned}$$

When X is included in the set device, make it as follows

When only X is specified, the number of points that can be processed per exchange is one half the value shown in the table.

*3 Commands can only be executed for QE71 in the same Ethernet's the remote node. Commands cannot be executed for remote station QE71 via data link systems or network systems.

*4 If a system protect is applied to the QnACPU that is executing the command (system protect switch SW5 is on), an error will occur, and an error response message will be returned.

*5 If a data write/read key word for the QnACPU that is executing the command is registered, specify the same key word in the command message. If the key words do not match, an error will occur and an error response message will be returned.

Corresponding PLC CPUs that can execute commands														PLC CPU state *1			Reference Item	
A0J2	A0J2 H	A1, A1N	An(N) (Other than left), AnS	A3H, A3M	A2C, A52G, A2CJ	AnA	AnU	AJ72 P25/R25	QLP 25 LP25 / QBR 15 BR15	Q2A Q2AS Q2ASH (S1)	Q3A	Q4A Q4AR	A73	A7L MS-F	During STOP	During RUN		
																Write possible setting		Write not possible setting
															○	○	○	Item 10.7
															○	○	○	
															○	○	○	
															○	○	○	
															○	○	○	Item 10.3
															○	○	○	Item 10.8
															○	○	○	Item 10.9

○ : Command execution possible × : Command execution not possible
 — : Accesses the QE71

*6 When a command is executed for the program file and a data write/read key word is registered in the corresponding QnACPU, set the same key word in the command message. If the key words do not match, an error will occur and an error response message will be returned.

*7 "Access station-1" shows the number of points processed during access to either of the following stations.

- ① QE71 connection station (local station).
- ② QnACPU stations (remote stations) via MELSECNET/10, MELSECNET/10 remote I/O stations.

*8 "Access station-2" shows the number of points processed during access for stations other than those described in *7 above.

(Example)

- ① PLC CPU stations other than QnACPU.
- ② PLC CPU stations and remote I/O stations via MELSECNET (II) and MELSECNET/B.

*9 Multiple block batch read and write can be performed for QnACPU shown in Item 2.5.3.

Point
 When using functions other than those in Item 9.2.1, execute the E71 commands given in Item 9.2.2.

9.2.2 List of E71 Commands and Functions

This section explains the functions and describes the processing of E71 commands.

E71 commands can be used for QnACPU and A series PLC CPUs and can access device memories.

QnACPU and AnUCPU device memories can be accessed within the AnACPU range.

Functions		Command/ response types	Description of processing	Number of points processed performed for 1 exchange		
Device memory ^{*5}	Batch read	Bit unit	00H	Bit devices (X, Y, M, etc.) are read in 1 point units.	256 points	
		Word unit	01H	Bit devices (X, Y, M, etc.) are read in 16 point units. Word devices (D, R, T, C, etc.) are written in 1 point units. ^{*3}	128 words (2048 points) 256 points	
	Batch write	Bit unit	02H	Bit devices (X, Y, M, etc.) are written in 1 point units.	256 points	
		Word unit	03H	Bit devices (X, Y, M, etc.) are written in 16 point units. Word devices (D, R, T, C, etc.) are written in 1 point units. ^{*3}	40 words (640 points) 256 points	
	Test (Random write)	Bit unit	04H	Bit devices (X, Y, M, etc.) are set and reset in 1 point units and the devices and device No. are randomly set.	80 points	
		Word unit	05H	Bit devices (X, Y, M, etc.) are set and reset in 16 point units, and the devices and device No. are randomly set. Word devices (D, R, T, C, etc.) are written in 1 point units, and the devices and device No. are randomly set.	40 words (640 points) 40 points	
	Monitor data registration	Bit unit	06H	Bit devices that monitor (X, Y, M, etc.) are registered in 1 point units.	40 points ^{*2}	
		Word unit	07H	Bit devices that monitor (X, Y, M, etc.) are registered in 16 point units. Word devices that monitor (D, R, T, C, etc.) are registered in 1 point units.	20 words (320 points) ^{*2} 20 points	
	Monitor	Bit unit	08H	Device monitors for which monitor data registration was conducted.	(Number of registrations portion)	
		Word unit	09H			
	Special function module	Batch read		0EH	Reads the buffer memory data of special function module.	256 bytes
		Batch write		0FH	Writes the buffer memory data of special function module.	(128 words)
Extension file register	Batch read		17H	Extension file registers (R) are read in 1 point unit.	256 points	
	Batch write		18H	Extension file registers (R) are written in 1 point unit.	256 points	
	Test (Random write)		19H	Extension file registers (R) are written in 1 point units and the block No. and device No. are randomly set.	40 points	
	Monitor data registration		1AH	The extension file registers that monitor (R) are registered in 1 point units.	20 points	
	Monitor		1BH	Monitors the extension file registers (R) that conduct the monitor data registration.	—	
	Direct read		3BH	Reads in 1 point units the extension file registers (R) that are directly set.	256 points	
	Direct write		3CH	Reads in 1 point units the extension file registers (R) that are directly set.	256 points	

	Corresponding PLC CPUs that can execute commands														PLC CPU state *1			Reference Item *4	
	A0J2	A0J2 H	A1, A1N	An(N) (Other than left), AnS	A3H, A3M	A2C, A52G, A2CJ	AnA	AnU	AJ72 P25/ R25	QLP 25 LP25 / QBR 15 BR15	Q2A Q2AS Q2ASH (S1)	Q3A	Q4A Q4AR	A73	A7L MS-F	During STOP	During RUN		
															Write possible setting		Write not possible setting		
	x				○				x							○	○	○	Item 10.2.2
	x				○				x							○	○	○	Item 10.2.3
	x				○				x							○	○	○	Item 10.2.3
	x				○				x							○	○	x	Item 10.2.4
	x				○				x							○	○	x	Item 10.2.5
	x				○				x							○	○	x	Item 10.2.6
	x				○				x							○	○	x	Item 10.2.7
	x				○				x							○	○	○	Item 10.2.8
	x				○				x							○	○	○	
	x				○				x							○	○	○	
					○				○		x					○	○	○	Item 10.4.2
					○				○		x					○	○	x	
	x	○	x		○					x						○	○	○	Item 10.3.3
	x	○	x		○					x						○	○	x	Item 10.3.4
	x	○	x		○					x						○	○	x	Item 10.3.5
	x	○	x		○					x						○	○	○	Item 10.3.6
	x	○	x		○					x						○	○	○	
	x	○	x		○					x						○	○	○	
	x	○	x		○					x						○	○	○	Item 10.3.7
	x	○	x		○					x						○	○	○	

*1 Use the QE71's exchange condition setting switch (SW7: exchange timing setting) to set whether it is possible to write to the PLC CPU during RUN.

- SW7 = ON Write possible during RUN (Enable)
- SW7 = OFF Write not possible during RUN (Disable)

*2 For other than A3HCPU, AnA, AnU, QnACPU, 2 points worth of points are processed for each point for device X (input).

When X is included in the specified device, make it as follows

$$\begin{array}{l}
 (\text{Number of X's specified points} \times 2) \quad \text{number of points processed} \\
 + \text{ number of other device specified points} \leq \quad \text{per one exchange}
 \end{array}$$

When only X is specified, the number of points that can be processed per exchange is one half the value shown in the table.

*3 When reading or writing extension file registers other than QnACPU, use the extension register's special command.

*4 The reference items shown in the table are the reference item numbers for the following manuals.

- For A Ethernet Interface Module User's Manual

Of the commands that can be used by the QE71, this manual only covers the QE71 commands. When using E71 commands, refer to Chapter 9 of this manual and applicable item of the above manual. Do not use commands other than those described in those items.

*5 For the QnACPU, only devices with the same names as the devices existing in AnCPU, AnNCPU, AnACPU, and AnUCPU can be accessed. (Except below)

The following devices for QnACPU cannot be accessed from remote node:

- Devices newly added to the QnACPU
- Latch relay (L) and step relay (S)
 - * For the QnACPU, the latch relay (L) and step relay (S) are separate devices from internal relays (M), but access will be made to internal relays when either one is specified.
- File register (R)

QnACPU accessible devices (Accessible with E71 commands)...When the parameter settings are the default							
Classification	Device	Device No. (Settings range)	Decimal/hexadecimal expression	Classification	Device	Device No. (Settings range)	Decimal/hexadecimal expression
Internal user device	Input relay	X0 to X7FF	Hexadecimal expression	Internal user device	Timer	Contact point	Decimal expression
	Output relay	Y0 to Y7FF				Coil	
	Internal relay	M0 to M8191 **3	Current value			TC0 to TC2047	
			Decimal expression		Counter	Current value	TN0 to TN2047
	Link relay	B0 to BFFF				Contact point	CS0 to CS1023
	Enunciator	F0 to F2047	Decimal expression			Coil	CC0 to CC1023
	Data register	D0 to D6143			Current value	CN0 to CN1023	
	Link register	W0 to WFFF	Hexadecimal expression		Internal system device	Special relay **1	M9000 to M9255
						Special register **2	D9000 to D9255

**1 Access for SM1000 to SM1255 is set at M9000 to M9255.

**2 Access for SD1000 to SD1255 is set to D9000 at D9255.

9.3 PLC CPU Operation During Data Exchange

This section explains the PLC CPU operation when reading and writing data to the PLC CPU is conducted.

1 PLC CPU scan time

Access to the QE71 and PLC CPU is processed once for each request for each END processing when the PLC CPU is running when a request is received from the QE71. Therefore, this will increase the scan time processing time. For information regarding the PLC CPU interrupt time required for communication between the QE71 and the PLC CPU, refer to Appendix 3.

2 Simultaneous access to the QnACPU

The processing during simultaneous access differs depending on the QnACPU's parameter "PLC system setting."

- ① When the parameter's "PLC system settings" are not set

Only one request is processed for END processing by the QnACPU.

When the same QnACPU is accessed at the same time from a module and the GPP, the access is made to wait until other processing is completed, so the number of scans required for the processing is increased. Placing COM commands in the sequence program will increase the COM command's execution time scan time making it possible to process multiple accesses within one scan.

- ② When the parameter's "PLC system settings" are set

If the "PLC system settings" general data processing setting is conducted, the QnACPU will process the requests for general data processing settings using END processing. For example, if the "PLC system setting" general data processing setting is "4," the QnACPU can process all of a maximum of 4 access requests from a module and GPP during the scan's END processing time. In addition, putting in COM commands increases the COM command execution time's scan time, making it possible for the QnACPU to process all of a maximum of 4 access requests from a module and GPP during the COM command's execution time.

9.4 Data Exchange Precautions

Following is a list of precaution items for when reading and writing data in the PLC CPU is conducted.

- 1** **Conduct reading/writing when the following QE71's I/O signals are on.**
 - ① When automatic open UDP port is used
Initial normal end signal (X19)
 - ② When the user uses the open port
When the initial normal end signal (X19) and the open end signal (X10 to X17) of the connection to be used are turned on, reading and writing of data in the PLC CPU from a remote node can be conducted regardless of the existence of a sequence program.
- 2** **When writing data during the PLC CPU is running, set the exchange condition setting switch (SW7: CPU exchange timing setting) of the QE71 to on.**
- 3** **When conducting PLC CPU remote stop use the automatic open UDP port. Or use the data exchanging function while the PLC CPU is stopped (refer to Chapter 16).**
- 4** **When the usage availability of the connection being opened is without procedure, reading and writing data in the PLC CPU cannot be conducted.**
- 5** **When using an automatic open UDP port, ASCII code exchange cannot be conducted.**
- 6** **Changing the remote station PLC CPU to which data will be exchanged.**

After the QE71 is booted up, remote station PLC CPU information is read in and stored. To change the remote station PLC CPU to which data will be exchanged after the QE71 is booted up, reboot the QE71 after changing the PLC CPU's model name. (Local station PLC power reset/CPU reset)
- 7** **When transmitting a command for reading/writing data in the PLC CPU, send the next command after the completion of the data communication for the transmission of the previous command.**
- 8** **Read the manual carefully and take reasonable precautions for controlling (especially changing data, program, or condition of operation (remote RUN/STOP)) the PLC in operation by connecting other Personal computer, etc. to the special module. Making mistaken data changes, program changes, or operation status changes will result in system malfunction and damage to or accidents with the machinery.**

10. WHEN READING/WRITING DATA IN THE PLC CPU WITH QE71 COMMANDS

This section explains the data formats and control methods used when QE71 commands are used to read and write device and program data in the PLC CPU.

10.1 Data Format

This section explains the data formats used for transmission and reception between the QE71 and remote nodes.

As shown below, the communication data consists of a header and the application data.

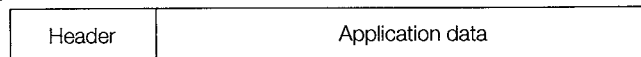

10.1.1 Header

The header is a TCP/IP or UDP/IP header. For the QE71, QE71 will be added, so there is no need for this to be set by the user.

10.1.2 Application Data

As shown below, the application data is largely divided into subheader and text.

The subheader shows the commands and response, and the setting value is set.

The text data sets the request data (command) for each function and the return data (response), so the data is set using standard formats. (For details, refer to Item 10.2 and later.)

1 Format

During ASCII code exchange

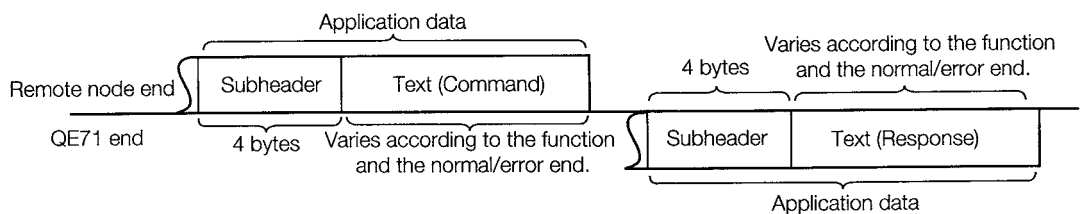

During binary code exchange

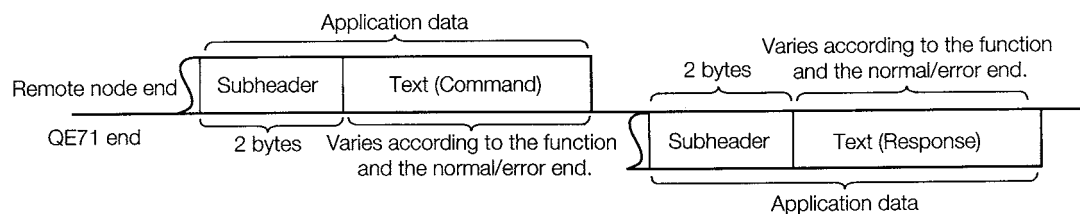

Remarks

The responses to commands from remote nodes during reading and writing data in the PLC CPU are created and returned by the QE71, so the user does not need to set these.

2 Subheader

During data exchange, the following codes and sequences are transmitted and received.

	Command				Response			
Using ASCII codes	5 35H	0 30H	0 30H	0 30H	D 44H	0 30H	0 30H	0 30H
Using binary codes	50H		00H		D0H		00H	

3 Text (Command/response)

The text (command/response) format is configured as shown on the following page.

The data code(ASCII/binary) used for transmission and reception of commands and responses between the QE71 and a remote node are set using the exchange condition setting switch (SW2:data code setting) of the QE71.

Transmit the values handled by the items in the command and response by the QE71 and the remote node to which communication is being conducted using the following codes in accordance with the above settings. In addition, conduct reception using the following codes. In the explanations for items hereafter, the values handled by the items in the command and responses will be shown as binary values.

(1) For binary code exchange

Unless otherwise explained, the values shown in the explanations are the binary values and are transmitted and received in the specification order (L to H).

(2) For ASCII code exchange

Unless especially explained, the values given in the explanations are converted into hexadecimal ASCII code and are transmitted and received in the specification order (H to L).

(a) Command format

For ASCII code exchange

(Example) When 8 points are read from the command 0401H and subcommand 0001H internal relay M100 to M107.

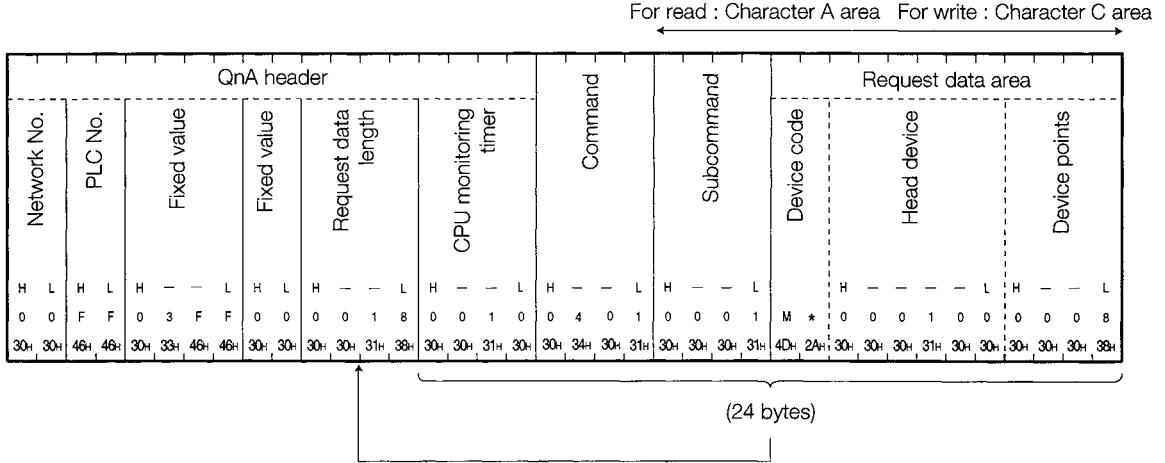

For binary code exchange

(Example) When 8 points are read from the command 0401H and subcommand 0001H internal relay M100 to M107.

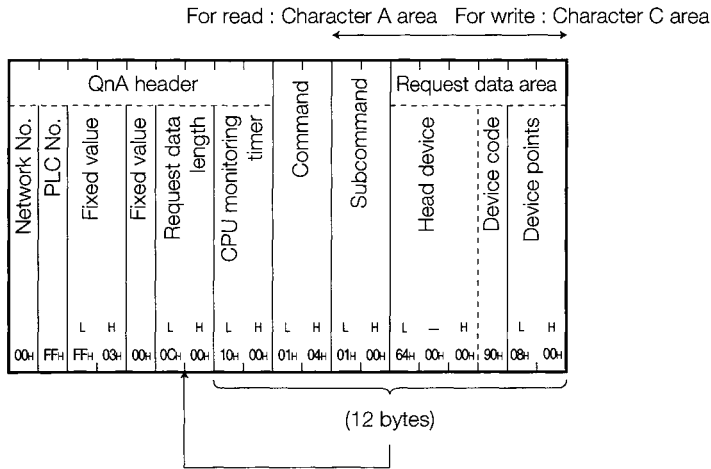

① Network No., PLC No.

When accessing a remote station PLC, set the No. of the network system/data link system that was passed through last, the access station's PLC No. in the corresponding system, and the setting No. of the network module, etc., as shown below.

Item 9.1 shows a specifying example.

	Remote node access station		Remote node specifying No.	
			Network No.	PLC No.
1	QE71 connection station (Local station)		00H	FFH (*1)
2	Control station for network between PLCs on the MELSECNET/10 (When installed in the QE71's regular station)	Except 1 above	01H to EFH (1 to 239) (*2)	7DH
	Remote I/O net master station on the MELSECNET/10 (When the QE71 is installed in the remote station)			
3	Stations on the MELSECNET/10	Except 1 and 2 above		01H to 40H (1 to 64) (*3)
4	Master stations on the MELSECNET (II) (When the QE71 is installed in the local station)	Except 1 above	00H	00H (*3)
5	Local stations and remote stations on the MELSECNET (II) (When the QE71 is installed in the master station)			01H to 40H (1 to 64) (*3)
6	Stations on the MELSECNET/B			Same as 4 and 5 above.
7	"Valid module during remote station access" settings network module pass through station		FFH (254)	01H to 40H (1 to 64) (*3)

*1 Only valid for PLC No. FFH and network No.00H.

*2 Specifies the access station's network No.

*3 Specifies the access station's station No.

Point

- (1) The network module network No. setting switch and the station No. setting switch are set using decimal numbers, but No. specified when ASCII code is used, are set with hexadecimal numbers.
(Example) Setting switch network No. "10" Specified network No. "0A"
- (2) Access the network No. via 240 to 255's MELSECNET/10 is not possible.
- (3) When the network No. FEH is specified to access a remote station via the data link system or network system that includes a QE71 installed station, set the following parameters in the QE71's installed station PLC CPU using GPP.
 - Setting for "valid module when accessing remote stations"Set up within the number of modules setting, and then set a module to go through when accessing remote stations.

② Fixed values

Set the fixed values shown in the diagrams regardless of other specified items.

③ CPU watchdog timer

To this timer, set the waiting time from when the QE71 (that has received request data from an external device) output a read/write request to the PLC CPU until the result is returned.

- Specify the setting with the following value.

0000H (0) : Endless waiting *1

0001 to FFFFH (1 to 65535) : Waiting time (unit: 250ms)

*1 The QE71 keeps waiting until a response is returned from the PLC CPU.

- To make normal data communication, it is recommended to use the timer in the setting range given in the following table depending on the communication destination.

Setting Range	Communication Destination
1 to 40H (0.25 to 10 seconds)	Host or other station via MELSECNET(I) or /B
2 to 240H (0.5 to 60 seconds)	Other station via MELSECNET/10 or other station by router relay

④ Request data length

Specify the byte size from the CPU monitoring timer item in the text until the end of the request data portion.

⑤ Command · Subcommand

Specify the command and subcommand that show the request contents when a read or write data in the PLC CPU is conducted from a remote node.

Set the commands and subcommands of the functions shown from Item 10.2 and later to match the read/write request contents.

⑥ Request data area

Specify the data (head device, read write range, write data, etc.) to be used when the following commands and subcommands are specified from a remote node to perform read write data to the PLC CPU.

Specify the data to be used by the commands and subcommands of the functions

(b) Response format during normal end

For ASCII code exchange

(Example) When the 8 points for the command 0401H and subcommand 0001H internal relays M100 to M107 are read.

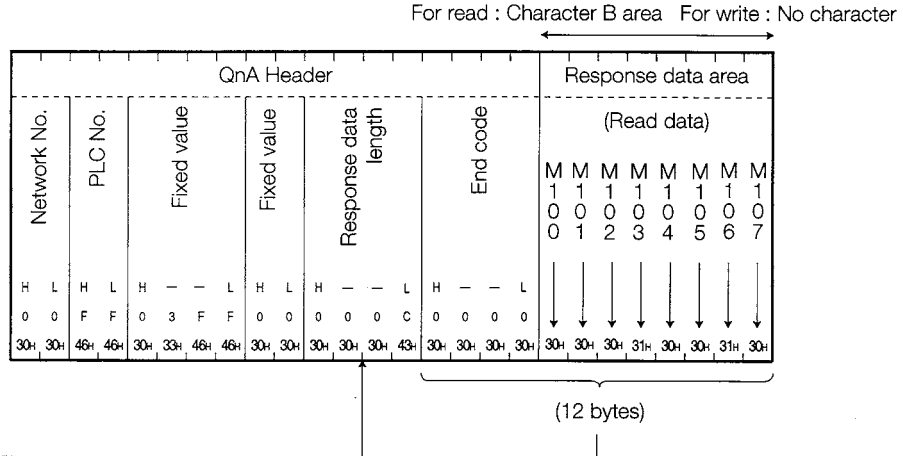

For binary code exchange

(Example) When the 8 points for the command 0401H and subcommand 0001H internal relays M100 to M107 are read.

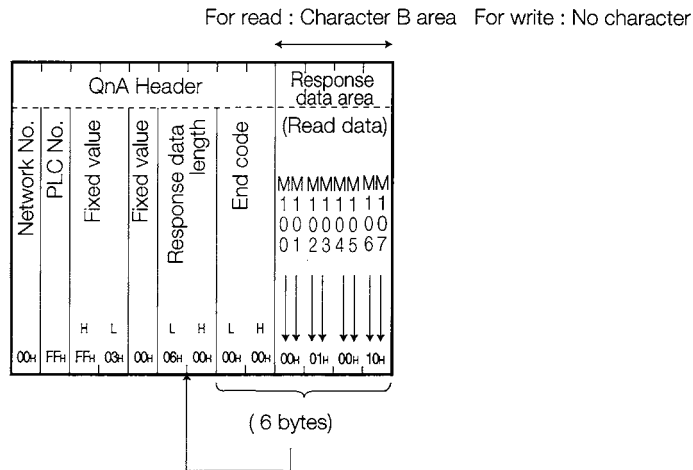

- ① Network No., PLC No.
The access station PLC network No. and PLC No. are returned.
- ② Fixed values
The fixed values shown in the diagram are returned regardless of the other fixed item values.
- ③ Response data length
The byte size from the end code item in the text until the end of the response data area is returned.
- ④ End code
The command processing results are returned. The values shown in the diagram are returned during normal end.
- ⑤ Response data area
The read data/write results for the read/write request specified by the remote node's commands and subcommands are returned.
The response data area's contents and order differs depending on the read/write request specified by the command and subcommand.
Refer to the explanation items for the functions described in Item 10.2 and later.

(c) Response format during error end

For ASCII code exchange

(Example) When there is a read error end for the command 0401H and subcommand 0001H.

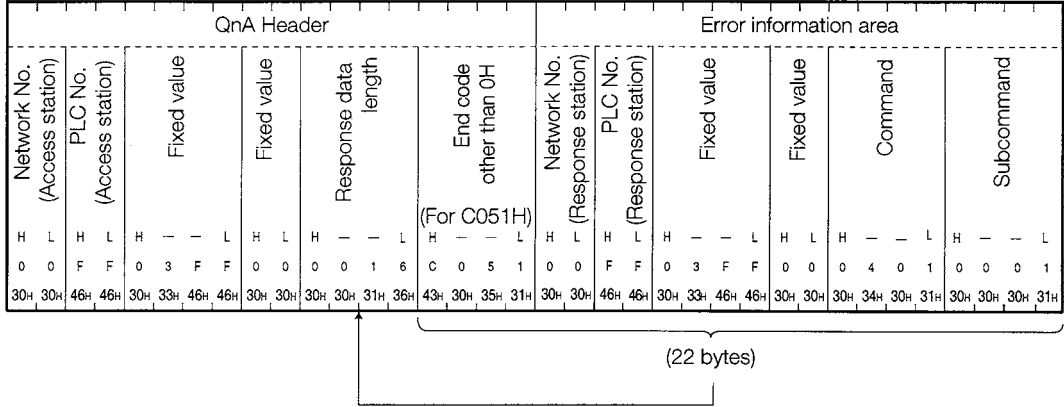

For binary code exchange

(Example) When there is a read error end for the command 0401H and subcommand 0001H.

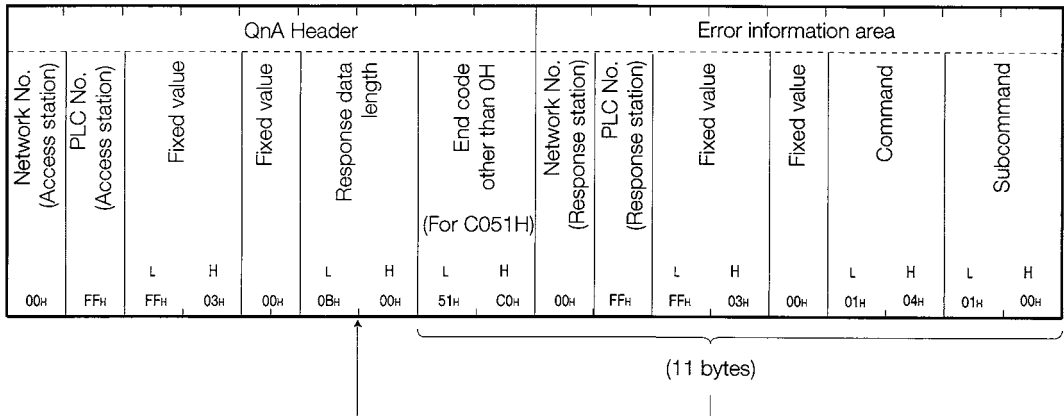

- ① Network No., PLC No. (Access station)
The access station PLC network No. and PLC No. values are returned.
- ② Fixed values
The fixed values shown in the diagram are returned regardless of the other specified item values.
- ③ Response data length
Returns the byte size from the end code item in the text until the end of the error information portion.
- ④ End code
The error code (0050H or more) during error end is returned. Conduct the processing for this that is described in Chapter 17.
- ⑤ Error information area
Returns the PLC that issued the error response and the command at the time the error occurred, etc.
 - (a) Network No. and PLC No.
Returns the PLC network No. that issued the error response and the PLC No.
 - (b) Command and subcommand
Returns the command and subcommand at the time the error occurred.

10.1.3 Thinking Regarding Data Transmission

This section explains the thinking regarding the transmission data that handles the character portions when data is transmitted and received between a remote node and the PLC using commands.

For read/monitor the transmission data shown in the example becomes a character B portion, and for write/test/monitor data registration, the transmission data shown in the example becomes the character C portion.

1 When data is exchanged using ASCII code

(a) During bit device memory read and write

The bit device memory is sometimes handled in bit units (1 point unit) and word units (16 points).

The following explains the thinking regarding the various transmission data.

① Bit unit (1 point unit)

When the bit device memory is handled in bit units, and if the specified device number of points portion from the specified head device are turned on in order from the left, then "1" (31H) is displayed and if off, then "0" (30H) is displayed.

(Example) When the 5 points from M10 are displayed in on/off.

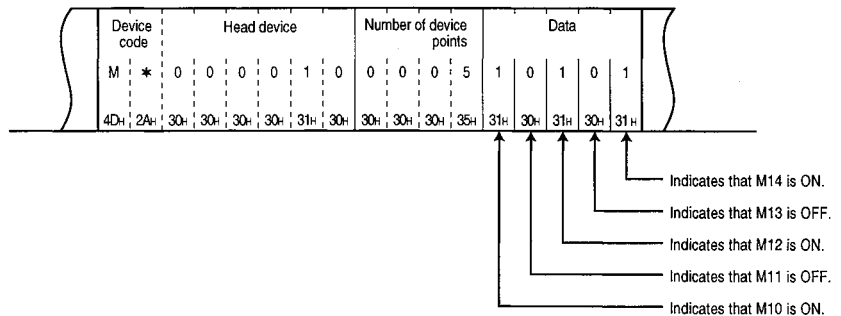

② Word unit (16 point unit)

When the bit device memory is handled in word units, one word is 4 bit units and the word is displayed in order from the first bit using hexadecimal numbers.

(Example) When the 32 points from M16 are displayed in on/off.

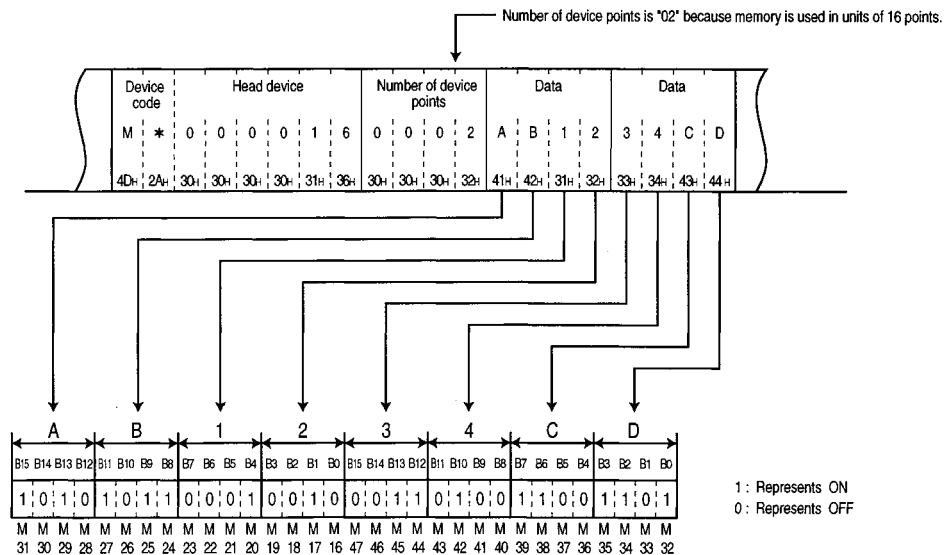

(b) During word device memory read and write

The word device memory is one word of 4 bit units which are displayed from the first bit in order using hexadecimal numbers.

(Example) When the stored contents in data registers D350 and D351 are displayed.

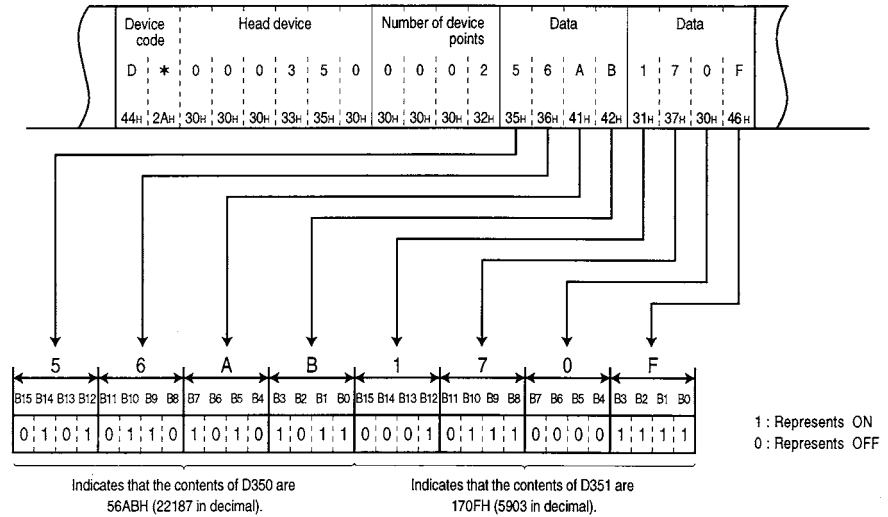

Point

- (1) Use the capital character codes when alpha characters are specified for the character portion.
- (2) When other than integers (real numbers, character strings) are stored in the word device memory that will read the data, the QE71 reads the stored values as integer values.

(Example 1) When real numbers (0.75) are stored in D0 to D1, the following integer values are read.
 D0 = 0000H, D1 = 3F40H

(Example 2) When character strings (12AB) are stored in D2 to D3, the following integer values are read.
 D2 = 3231H, D3 = 4241H

Remarks

The same thinking as used for the word device memory also applies to word data that handles buffer memory reading and writing.

2 When data is exchanged using binary code

(a) When reading and writing bit device memories

Sometimes bit device memory is handled in bit units (1 point units), and sometimes by word units (16 points).

This section explains the thinking regarding these transmission data.

① Bit unit (1 point unit)

When bit device memories are handled in bit units, 1 point is specified as 4 bits and if the specified device number of points portions from the specified first device is in the order from the head bit is on, then the display is "1," and if off, the display is "0."

(Example) When the 5 points from M10 are displayed in on/off.

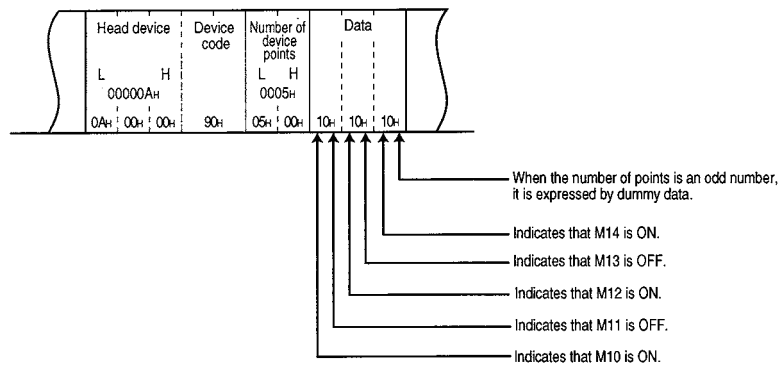

② Word unit (16 point unit)

When the bit device memory is handled in 1 word units, 1 point is specified as 1 bit, and the specified device number of points from the specified head device is 16 point units, so the bits are expressed in the order from Low bytes (L : bits 0 to 7) to the High byte (H : bits 8 to 15).

(Example) When the 32 points from M16 are displayed in ON/OFF.

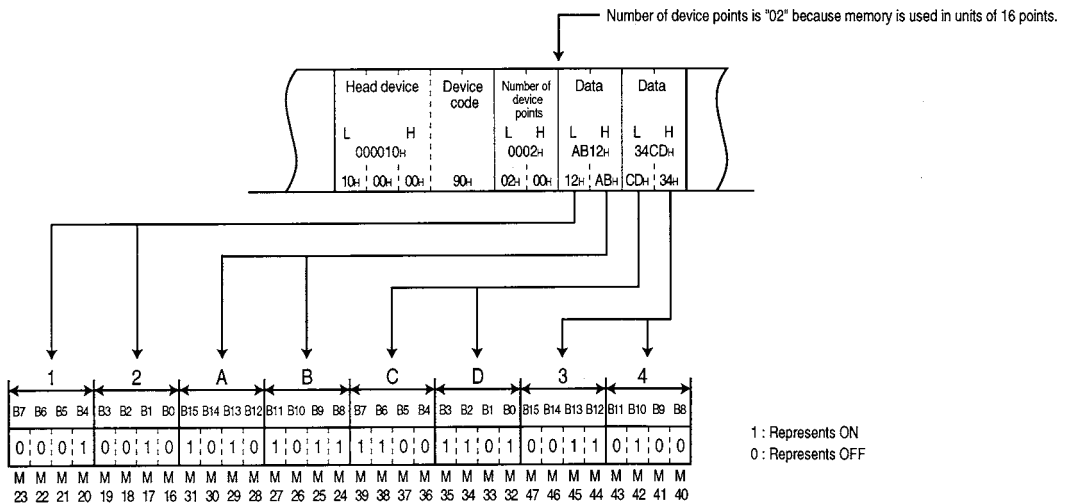

(b) When reading and writing word device memory

The word device memory is specified in one word as 16 bits, so the specified device number of bits from the specified head device is in 1 bit units, and the bits are displayed in the order from the Low byte (L : bits 0 to 7) to the High byte (H : bits 8 to 15).

(Example) When the stored contents in data registers D350 and D351 are displayed.

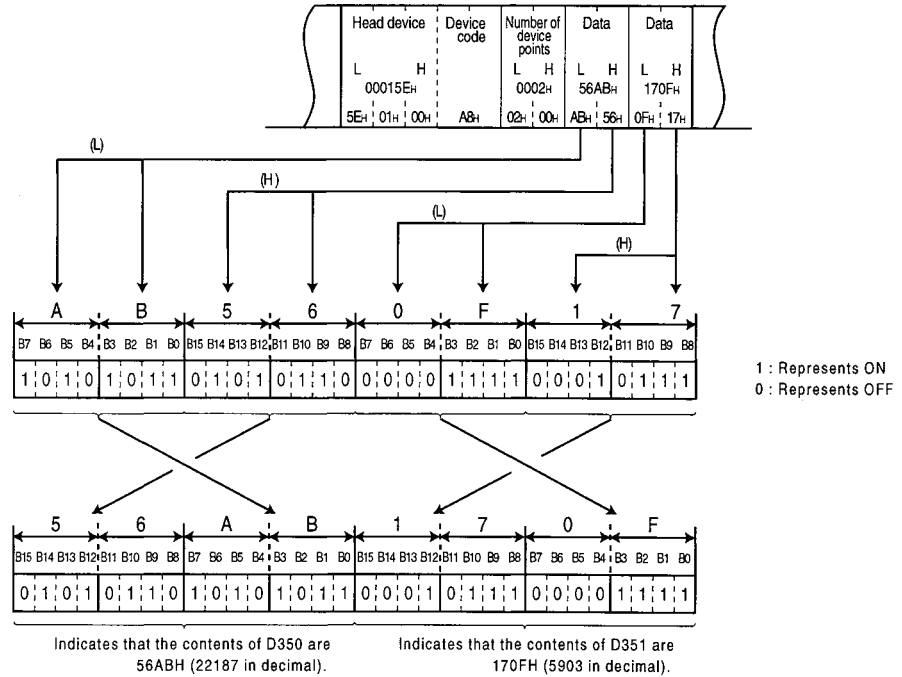

Point

When other than integers (real numbers, character strings) are stored in the word device memory that will read the data, the QE71 reads the stored values as integer values.

(Example 1) When real numbers (0.75) are stored in D0 to D1, the following integer values are read.

D0 = 0000H, D1 = 3F40H

(Example 2) When character strings (12AB) are stored in D2 to D3, the following integer values are read.

D2 = 3231H, D3 = 4241H

Remarks

The same thinking as used for the word device memory also applies to word data that handles buffer memory reading and writing.

10.2 Device Memory Read/Write

This section explains the control method for reading and writing to and from the device memory.

10.2.1 Command and Character Area Contents and Device Range

This section explains about the commands, character portions, and access possible device range when reading and writing to and from device memories.

1 Command

Specify the command that corresponds to the function.

Table 10.1 List of Commands

Functions		Command (Subcommand) * For ASCII code: Specify each ASCII code. For binary code: Specify each numeral as hexadecimal numeral.	Description of processing	Number of points pro- cessed per 1 exchange		PLC CPU state *1			Reference Item
				Access station-1 (Refer to Item 9.2.1 ⁷⁾)	Access station-2 (Refer to Item 9.2.1 ⁸⁾)	During STOP	During RUN		
							Write pos- sible setting	Write not pos- sible setting	
Batch read	Bit unit	0 4 0 1 (00□1)	The bit device is read in 1 point units.	1792/3584 points	256 points				Item 10.2.1 Item 10.2.2 Item 10.2.3
	Word unit	0 4 0 1 (00□0)	Bit device is read in 16 point units.	480 words (7680 points)	32 words (512 points)	○	○	○	
			Word device is read in 1 point units.	480 points	64 points				
Batch write	Bit unit	1 4 0 1 (00□1)	Bit device is written to in 1 point units.	1792/3584 points	160 points				Item 10.2.1 Item 10.2.4 Item 10.2.5
	Word unit	1 4 0 1 (00□0)	Bit device is written to in 16 point units.	480 words (7680 points)	10 words (160 points)	○	○	×	
			Word device is written to in 1 point units.	480 points	64 points				
Random read	Word unit	0 4 0 3 (00□0)	Random specified bit device is read in 16 point and 32 point units. ^{*3}	96 points	10 words (160 points)	○	○	○	Item 10.2.1 Item 10.2.6
			Random specified word device is read in 1 point and 2 point units. ^{*3}		10 points				
Test (Random write)	Bit unit	1 4 0 2 (00□1)	Random specified bit device is set and reset in 1 point units.	94 points	20 points				Item 10.2.1 Item 10.2.7 Item 10.2.8
	Word unit	1 4 0 2 (00□0)	Random specified bit device is set and reset in 16 point and 32 point units. ^{*3}	960 points	10 words (160 points)	○	○	×	
			Random specified word device is written to in 1 and 2 point units. ^{*3}		10 points				
Monitor data registra- tion	Word unit	0 8 0 1 (00□0)	The bit device that will conduct monitor- ing is registered in 16 point and 32 point units. ^{*2 *3}	96 points	20 words (320 points)	○	○	○	Item 10.2.1 Item 10.2.9
			Word device that will conduct monitoring is registered in 1 and 2 point units. ^{*3}		20 points				
Monitor	Word unit	0 8 0 2 (0000)	Monitors the device that registered the monitor data.	(Number of registered points portion)		○	○	○	
Multiple block batch read	Word unit	0 4 0 6 (00□0)	Making n-points of word device and bit device (one point is 16 bits) as one block, read multiple blocks specified randomly.	480 points	(Not possible)	○	○	○	Item 10.2.1 Item 10.2.10
Multiple block batch write	Word unit	1 4 0 6 (00□0)	Making n-points of word device and bit device (one point is 16 bits) as one block, write multiple blocks specified randomly.	480 points	(Not possible)	○	○	×	

○ in the PLC CPU state column in the above table show executable items.

- *1 Use the QE71's exchange condition setting switch(SW7:exchange timing setting) to set the write possible/not possible during RUN setting for the PLC CPU.
 SW7 = ON Write possible during RUN (Enable)
 SW7 = OFF Write not possible during RUN (Disable)
- *2 When other than A3HCPU, AnA/AnU/QnACPU, 2 points are processed for each point for the device X (input). (When only X is specified, the number of points that can be processed per exchange is one half the value shown in the table.) When X is included in the specified device, process the number of points within the following range.

$$\left(\left(\begin{matrix} X \text{ specified number} \\ \text{of points} \times 2 \end{matrix} \right) + \begin{matrix} \text{other device specified} \\ \text{number of points} \end{matrix} \right) \leq \begin{matrix} \text{number of points processed} \\ \text{during one exchange.} \end{matrix}$$
- *3 The number of points processed other than for QnACPU, is 1 point units for word devices and 16 point units for bit devices.

2

Character area

This section explains the common data contents in the character portions of each control procedure when reading and writing data to the PLC by a remote node.

Point

- (1) The character area differs according to the contents of the command specified for use, and this document explains the character portion, data contents when the device memory that conducts reading and writing is directly specified.
- (2) Information regarding the character area data that only handles voluntary commands is shown in the explanation items of the corresponding command.
- (3) The following item explains the special data handled by some functions and the special data handled by special specifications.
 - Item 10.2.6 Special data specified by the word unit's random write (command : 0403) and monitor data registration (command : 0801).
 - Item 10.2.11 Data when an extension specification is used for the device memory that performs read and write.

(a) Character area data for ASCII code

(Example) During read

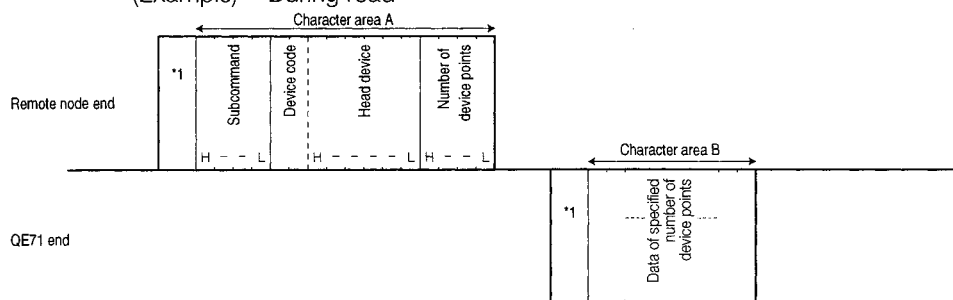

(Example) During write

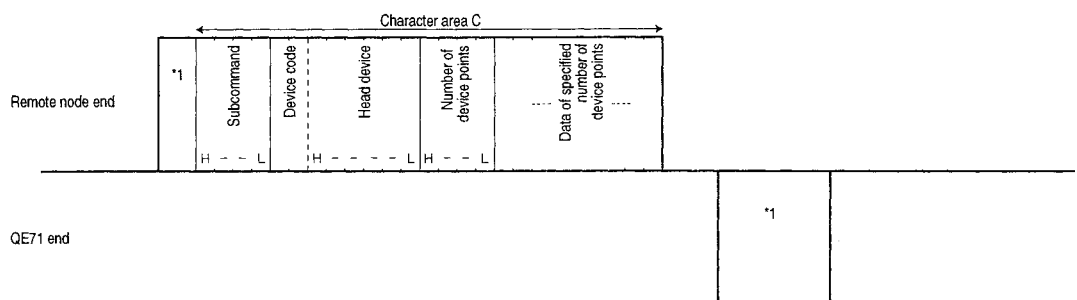

*1 The data order and contents are shown in Item 10.1.2.

(b) Character area data for binary code

(Example) During read

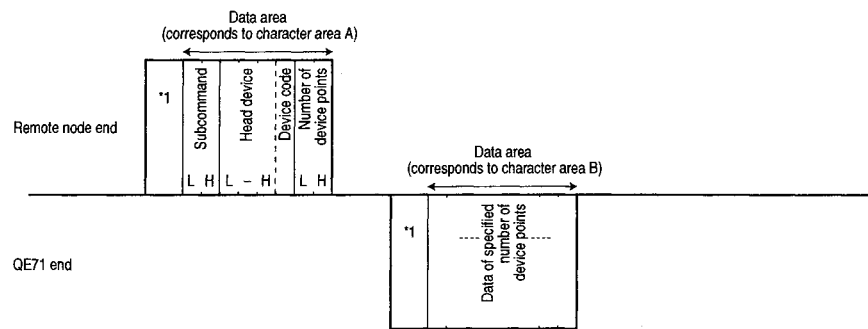

(Example) During write

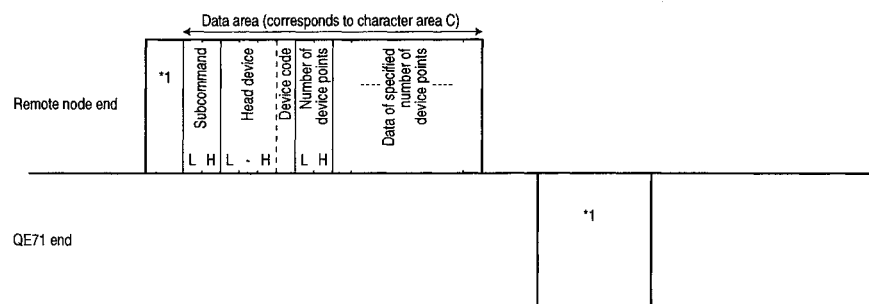

*1 The data order and contents are shown in Item 10.1.2.

(c) Character area's common data contents

① Subcommand

This data specifies the read/write units, type of device being specified, and data read conditions, etc.

(a) For data exchange using ASCII code

Convert 0000H (0) and the following number to 4 digit ASCII code (hexadecimal number) and transmit it starting with the first digit "0."

(b) For data exchange using binary code

Use 0000H and the following 2 byte number and transmit.

(c) The subcommand specified contents are as follows.

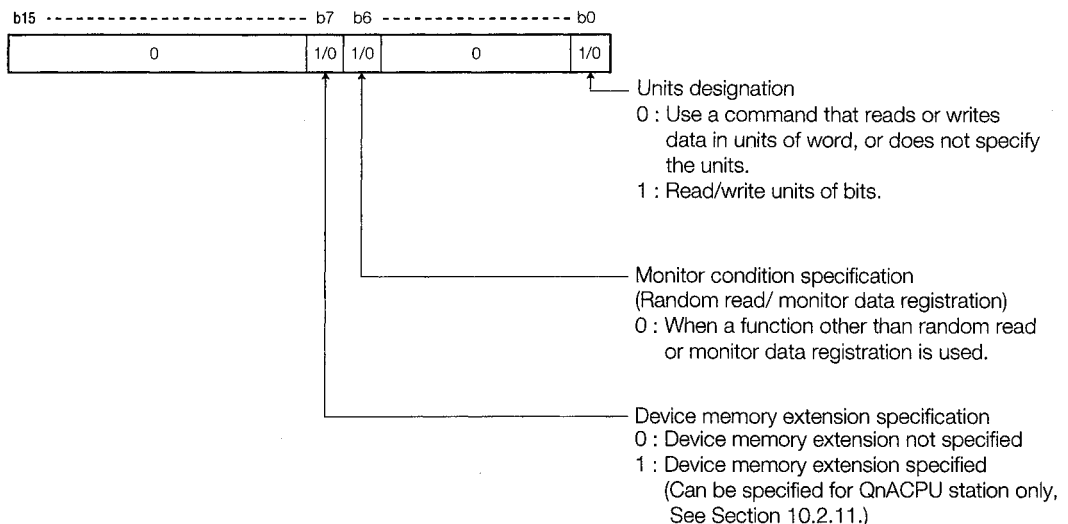

- (d) In the following case, the subcommand becomes 0000H/0001H.
- Select when the monitor conditions are not specified and when the device memory extension is not specified.
 - Use when the command cannot select monitor condition specification and device memory extension specification.

Point

The following QE71 installed station and remote station QnACPU device memory can be accessed using device memory extension specification for the subcommand's bit 7. Refer to Item 10.2.11. (Access is not possible via data link system.)

- ① QnACPU link direct device memory
- ② Special functions module buffer register (buffer memory)

② Device code

This data identifies which device memory will read/write the data.

(a) The device code is shown in the table in 3.

(b) For data exchange using ASCII code

Convert the device code to ASCII code two digits and transmit.

(Example) For input relay

Transmit in order from "X" for the input relay device code "X*." The second character "*", can be specified as blank (code : 20H).

(c) For data exchange using binary code

Transmit the 1 byte numerical value shown in the table in 3.

③ Head device (device)

This data is used to specify the No. of the device that will read/write the data. When specifying continuous device memory, specify the device memory range's head No. The head device No. is specified using the expression method (decimal or hexadecimal) to be displayed in the "expression" column in the table shown in 3 for the subject device memory.

(a) For data exchange using ASCII code

The device No. shown in the table is converted to ASCII code six digits and transmitted. "0" series ("0" shown in the first two characters of the series "001234") in the first digit can be used to specify a blank (code : 20H).

(Example) When the internal relay is M1234 and the link relay is B1234

When either the internal relay M1234 or the link relay B1234 are "001234" or "┐1234," then "0" or "┐" will be sent in order.

(b) For data exchange using binary code

The three byte numerical value shown in the table is transmitted.

(Example) When the internal relay is M1234 and the link relay is B1234

The internal relay M1234 becomes 0004D2H and is transmitted in the order of D2H, 04H, 00H.

The link relay B1234 becomes 001234H, and is transmitted in the order 34H, 12H, 00H.

④ Device number of points

This data is used to specify the number of points performed by read/write when each command is executed, and is specified within the number of points processed for one exchange as shown in the table in [1](#).

(a) For data exchange using ASCII code

The processing number of points is converted to ASCII code 4 digits (hexadecimal) and transmitted.

(Example)

For 5 points Becomes "0005" and is transmitted in order from "0."

For 20 points Becomes "0014" and is transmitted in order from "0."

(b) For data exchange using binary code

The two byte numerical value shown for the processing number of points is transmitted.

(Example)

For 5 points Becomes 0005H and is transmitted in the order 05H, 00H.

For 20 points Becomes 0014H and is transmitted in the order 14H, 00H.

⑤ Read data, write data

This data shows the write data contents to the specified device memory and the read data contents from the specified device memory, so the data order is changed by the processing unit (word/byte). For information regarding the data contents and order (transmission order), refer to Item 10.1.3.

⑥ Bit access number of points

This data is used to specify the number of points accessed by the bit unit, and is specified within the processing number of points conducted in one exchange as shown in the table in [1](#).

(a) For data exchange using ASCII code

The number of points is converted to ASCII code two digits (hexadecimal) and transmitted.

(Example)

For 5 points Becomes "05" and is transmitted in the order from "0."

For 20 points Becomes "14" and is transmitted in the order from "1."

(b) For data exchange using binary code

The one byte numerical value that shows the number of points is transmitted.

(Example)

For 5 points 05H is transmitted.

For 20 points 14H is transmitted.

⑦ Set/reset

This data is used to specify the data to be written to the bit device, and is specified to the value shown below.

Code	Write data		Remarks
	When on	When off	
ASCII Code	"01"	"00"	Two character transmission in the order from "0."
Binary Code	01H	00H	Transmits the 1 byte number shown at left.

3 Device range

Shows the PLC CPU device that can access using QE71 commands and the device No. range. Specify the device that exists in the subject module that conducts the data read and write and the device No. range.

(a) For QnACPU

Table 10.2 List of Accessible Devices (*1)

Classification	Device	Device type		Device code		Device No. range (When default allocated)	Expression		Remarks	
		Bit	Word	For ASCII code	For binary code		Dec.	Hex.		
Internal System	Function input	○		—	—	000000 to 00000F		○	Access not possible	
	Function output	○		—	—	000000 to 00000F		○		
	Function register		○	—	—	000000 to 000004	○			
	Special relay	○		S M	91H	000000 to 002047	○		—	
	Special register		○	S D	A9H	000000 to 002047	○		—	
Internal User	Input relay	○		X *	9CH	000000 to 001FFF		○	Change is possible within a total of 28.75k words (maximum of 32k points per device)	
	Output relay	○		Y *	9DH	000000 to 001FFF		○		
	Internal relay *2	○		M *	90H	000000 to 008191	○			
	Latch relay *2	○		L *	92H	000000 to 008191	○			
	Annunciator	○		F *	93H	000000 to 002047	○			
	Edge relay	○		V *	94H	000000 to 002047	○			
	Link relay	○		B *	A0H	000000 to 001FFF		○		
	Data register		○	D *	A8H	000000 to 012287	○			
	Link register		○	W *	B4H	000000 to 001FFF		○		
	Timer *3	Contact point	○		T S	C1H	000000 to 002047			○
		Coil	○		T C	C0H			○	
		Current value		○	T N	C2H			○	
	Integrating timer *3	Contact point	○		S S	C7H		○		
		Coil	○		S C	C6H		○		
		Current value		○	S N	C8H		○		
	Counter *3	Contact point	○		C S	C4H	000000 to 001023		○	
		Coil	○		C C	C3H			○	
		Current value		○	C N	C5H			○	
		Special link relay	○		S B	A1H	000000 to 0007FF		○	
		Special link register		○	S W	B5H	000000 to 0007FF		○	
	Step relay *2	○		S *	98H	000000 to 008191	○			
	Direct input	○		D X	A2H	000000 to 001FFF		○	Same as the input relay and output relay (for direct access)	
	Direct output	○		D Y	A3H	000000 to 001FFF		○		
—	Index register		○	Z *	CCH	000000 to 000015	○		—	
	File register *4 *5 *6		○	R *	AFH	000000 to 032767	○		Normal access by switching the block.	
				○	Z R	B0H	000000 to 0FE7FF		○	For continuous No. access

*1 Accesses the device memory in the QnACPU.
 The device range varies depending on the QnACPU version.
 For device range, see the User's Manual for the CPU which is used.
 Accessing local devices for each program is not allowed.

*2 For QnACPU internal relay (M), latch relay (L), and step relay (S) are separate devices.

*3 With random read, the timer, the integrating timer, the coil and contact point of the counter can only be specified for the QnACPU of function version B. The timer, the integrating timer, the coil and contact point of the counter cannot be specified for the QnACPU with monitor data registration.

Function	Command	QnACPU	
		Function version	
		A	B
Random read	0403	x	○
Monitor data registration	0801	x	

If any of the contact points or coils of the timer, integrating timer or counter is specified for an QnACPU for which these items cannot be specified, a 4032H error will be returned.

*4 When the PLC CPU's file register is accessed from a remote node, conduct access by specifying the following device code using the PLC CPU's file register configuration.

- ① When the file register is configured from multiple blocks
 - Specify a serial No. access device code with "ZR" for ASCII code, and "B0H" for binary code.
- ② When the file register is configured with only block 0
 - Specify either the sequential No. access or the normal access device code with "ZR"/"R*" for ASCII code, or "B0H"/"AFH" for binary code.
 - The device No. can be set to decimal numbers by specifying "R*," "AFH" for the normal access code.
 - When using sequential No. access during access, specify the device No. as hexadecimal.

Refer to the following manuals for information regarding the thinking regarding the file register device No. when sequential No. and normal access are used.

QnACPU QnACPU's programming manual (Fundamentals Edition)

Other than QnACPU AnACPU/AnUCPU programming manual (Special commands edition)

Remarks

Example sequential No. access device No. (For QnACPU)

ZR000000 (0) to	File register block No. 0 area (R0 to R32767)
ZR032767 (32767) to	File register block No.1 area (R0 to R32767)
ZR032768 (32768) to	File register block No.2 area
ZR065535 (65535) to	
ZR065536 (65536) to	

Device numbers for sequential number access are automatically assigned sequentially, starting with the existing block having the smallest block number.

* 5 Writing of data to the file register defined in the QnACPU EEPROM can only be performed when all of the following restrictions are cleared. If any of the following restrictions is not cleared, an abnormal termination message will be returned at the point data write to the file register is attempted.

(Restrictions when writing data to EEPROM file register)

- Write is allowed only using the batch write function (command 1401).
- Write is allowed only when the operation status of the subject QnACPU is “during stop” or “paused.”
- Write is allowed only with respect to the QnACPU types listed below as well as all QnACPU's manufactured in January, 1999 or later.

Types of QnACPU	Manufactured date	Software version
Q2ACPU (-S1), Q3ACPU, Q4ACPU	September to December, 1998	Version L and later
Q4ARCPU		Version S and later
Q2ASCPU (-S1), Q2ASHCPU (-S1)		Version T and later

Refer to the manual for subject QnACPU for the models not listed above.

* The manufactured date (year (last 2digits) and month (2digits)) can be verified in the “DATE field of the rated plate” located on the side of the module.

The module's software version can be verified on the seal (located in either of the dotted areas below) on the front of the module.

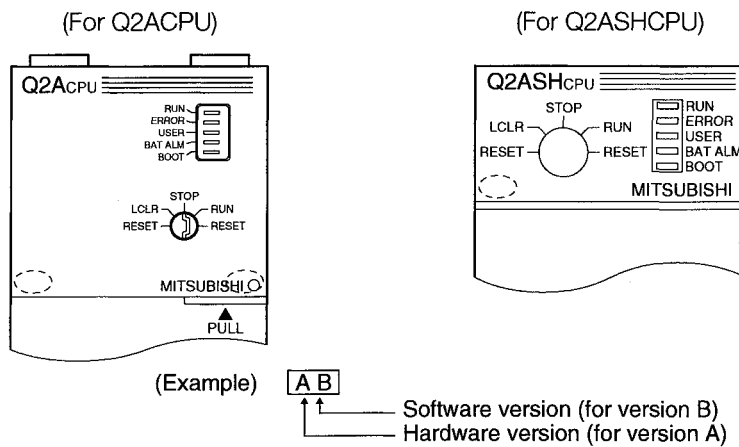

* 6 The file register for each program for which the same file name as the program has been assigned with a parameter cannot be accessed from a remote node.

(b) For other than QnACPU

Table 10.3 List of Accessible Devices (*7)

Device	Device type		Device Code		Device No. range	Expression		Remarks	
	Bit	Word	For ASCII code	For binary code		Dec.	Hex.		
Input	X	○	X *	9CH	000000 to 0007FF		○	Extension specification not possible	
Output	Y	○	Y *	9DH	000000 to 0007FF		○		
Internal relay	M	○	M *	90H	000000 to 008191	○			
Latch relay	L	○	L *	92H	000000 to 008191	○			
Step relay	S	○	S *	98H	000000 to 008191	○			
Link relay	B	○	B *	A0H	000000 to 000FFF		○		
Annunciator	F	○	F *	93H	000000 to 002047	○			
Special relay	M	○	M *	90H	009000 to 009255	○			
Timer T	Contact point	○	T S	C1H	000000 to 002047	○			Sets and accesses the existing device at the access destination and the device range.
	Coil	○	T C	C0H	000000 to 002047	○			
	Current value		○	T N	C2H	000000 to 002047	○		
Counter C	Contact point	○	C S	C4H	000000 to 001023	○			
	Coil	○	C C	C3H	000000 to 001023	○			
	Current value		○	C N	C5H	000000 to 001023	○		
Data register	D		○	D *	A8H	000000 to 008191	○		
Link register	W		○	W *	B4H	000000 to 000FFF		○	
File register	*8 R	○	R *	AFH	000000 to 008191	○		Normal access by switching the block.	
			Z R	B0H	000000 to 07FFFF		○	For continuous No. access.	
Special register	D		○	D *	A8H	009000 to 009255	○		

*7 Accesses to the device memory in the specified CPU.

Take caution regarding the following contents when accessing PLC CPU other than the QnACPU.

- (1) Access with a device No. range that can be used for the access destination PLC CPU.
- (2) Except for the QE71 installed station QnACPU and a QnACPU via MELSECNET/10, when accessing a PLC CPU using word units be sure to make the bit device No. in multiples of 16 (for decimal numbers 0, 16,...). After the special relay M's M9000 specification can be done as (9000 + multiples of 16).
- (3) Specify M for L and S when accessing these devices.
- (4) The special relay's (M9000 to M9255) and special registers (D9000 to D9255), are for special read, special write, and system use. Conducting a write in areas outside of the write possible range will cause a PLC CPU error. For details regarding the special relay and the special register, refer to the ACPU programming manual.

*8 Refer to (a)*4

10.2.2 Bit Units Batch Read (Command : 0401)

This section explains the control procedure for bit device memory batch read using an example.

(Control procedure)

1 When 8 points are read for the internal relay M100 to M107 for ASCII code exchange

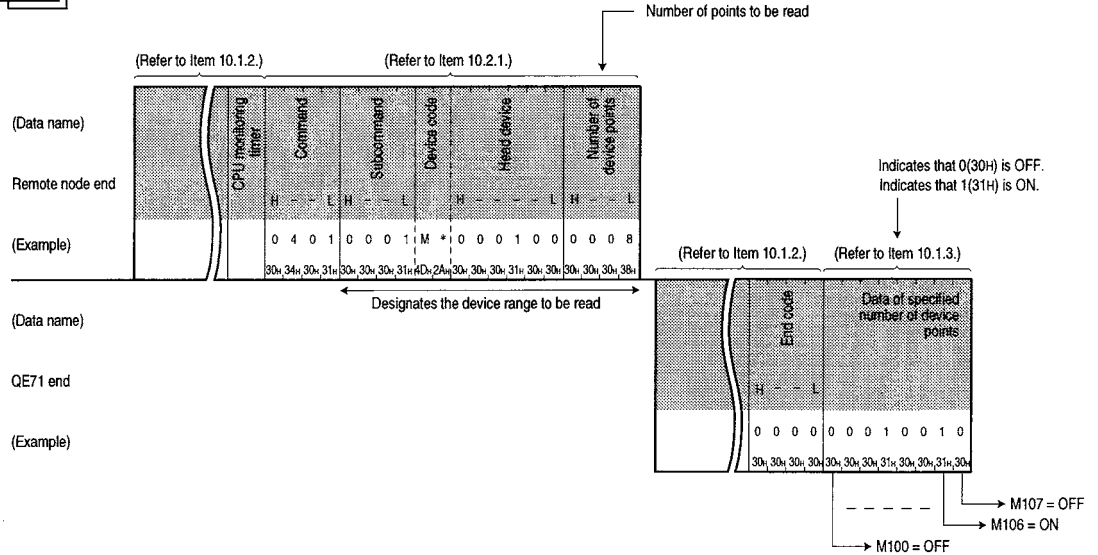

2 When 8 points are read for the internal relay M100 to M107 for binary code exchange

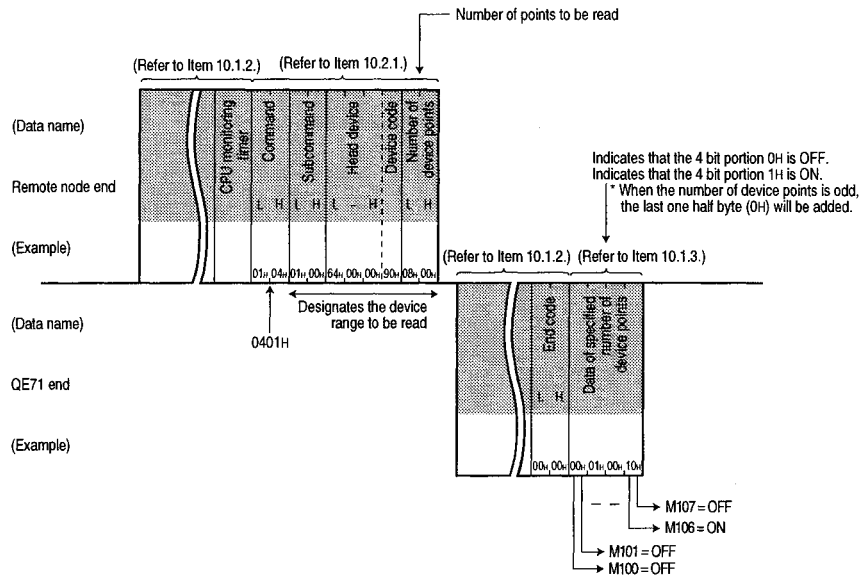

Point

Specify the number of device points within the following range.

(1) During QnACPU access via QE71 installed station QnACPU or MELSECNET/10

- Number of device points ... $1 \leq \text{number of device points} \leq 1792$ or 3584
 ASCII code : 1792 points, binary code : 3584 points
- Access range (Head device No. + number of device points - 1) \leq maximum device No.

(2) When accessing other than ① above

- Number of device points ... $1 \leq \text{number of device points} \leq 256$
- Access range (Head device No. + number of device points - 1) \leq maximum device No.

10.2.3 Word Units Batch Read (Command : 0401)

This section explains about the bit device memory (16 bit unit) and word device memory (1 word unit) batch read control procedure using an example.

(Control procedure)

1 When reading bit device memory

- (a) Reading the 2 point portion (32 bit portion) of the internal relay M100 to M131 during ASCII code exchange.

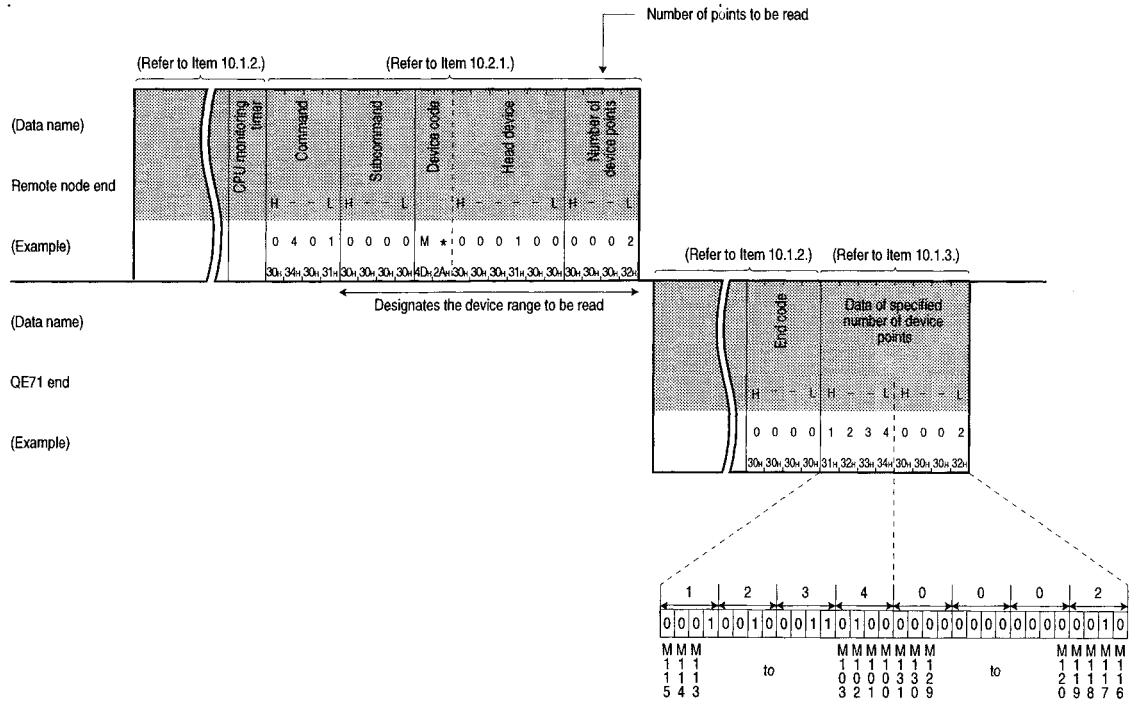

- (b) Reading the 2 point portion (32 bit portion) of the internal relay M100 to M131 during binary code exchange.

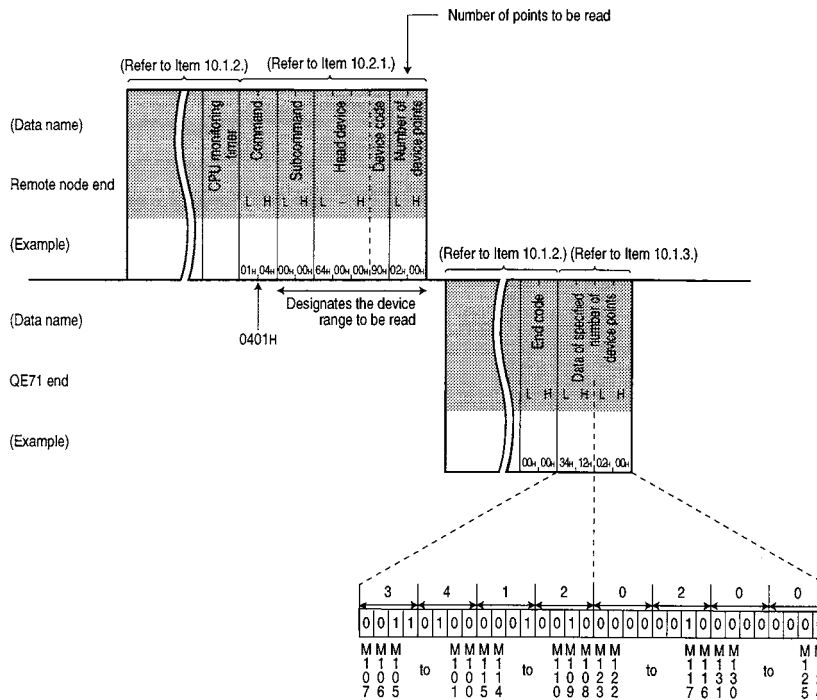

Point

- (1) Specify the number of device points within the following range.
The bit device is divided into 16 bits per one point.
 - ① When accessing the QnACPU via the QE71 installed station QnACPU or the MELSECNET/10
 - Number of device points $1 \leq \text{number of device points} \leq 480$... (480 words = 7680 bits)
 - Access range (Head device No. + number of device points \times 16 - 1) \leq maximum device No.
 - ② When accessing other than ① above
 - Number of device points $1 \leq \text{number of device points} \leq 32$... (32 words = 512 bits)
 - Access range (Head device No. + device number of points \times 16 - 1) \leq maximum device No.
- (2) When accessing PLC CPU bit devices other than those in ① above, be sure to set the head device No. to multiples of 16 (for decimal 0, 16,...).

2 When reading word device memory

(a) When reading the current value 3 points portion for the timer T100 to T102 during ASCII code exchange

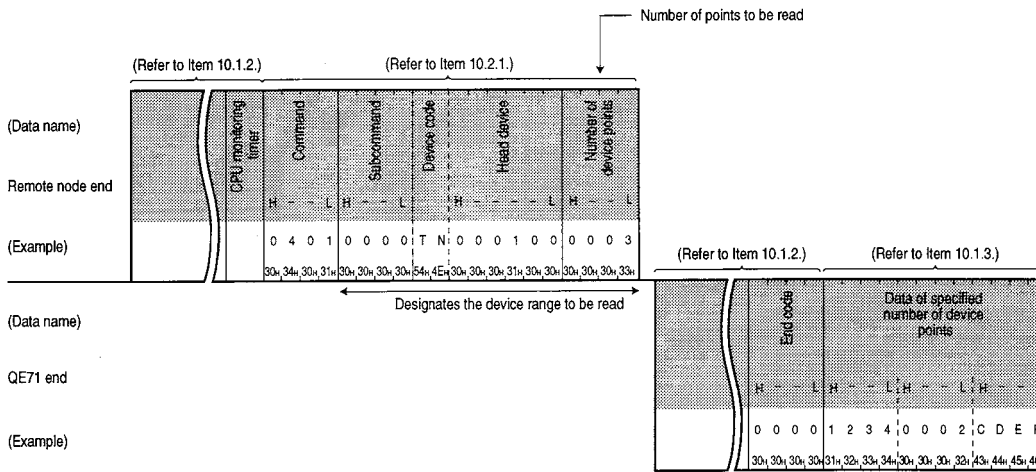

Indicates that the T100 current value 1234_H (hexadecimal) is 4660 in decimal.
 Indicates that the T101 current value 0002_H (hexadecimal) is 2 in decimal.
 Indicates that the T102 current value CDEF_H (hexadecimal) is -12817 in decimal.

(b) When reading the current value 3 points portion for the timer T100 to T102 during binary code exchange

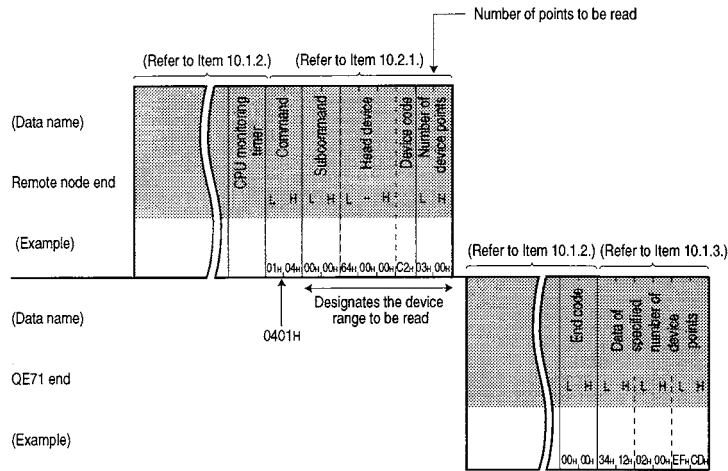

Indicates that the T100 current value 1234_H (hexadecimal) is 4660 in decimal.
 Indicates that the T101 current value 0002_H (hexadecimal) is 2 in decimal.
 Indicates that the T102 current value CDEF_H (hexadecimal) is -12817 in decimal.

Point

Set the number of device points within the following range.

- ① When accessing the QnACPU via the QE71 installed station QnACPU or MELSECNET/10
 - Number of device points 1 ≤ number of device points ≤ 480
 - Access range (Head device No. + number of device points - 1) ≤ maximum device No.
- ② When accessing other than ① above
 - Number of device points ... 1 ≤ number of device points ≤ 64
 - Access range (Head device No. + number of device points - 1) ≤ maximum device No.

10.2.4 Bit Units Batch Write (Command : 1401)

This section explains the control procedure for batch writing to bit device memory using an example.

(Control procedure)

- 1 When writing the 8 points portion to the internal relay M100 to M107 during ASCII code exchange

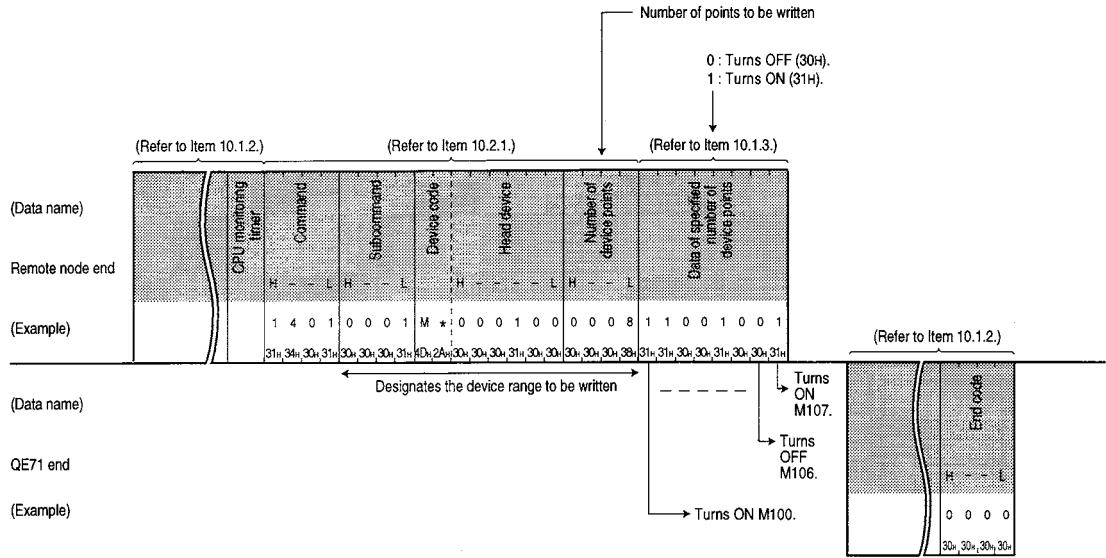

2 When writing the 8 points portion to the internal relay M100 to M107 during binary code exchange

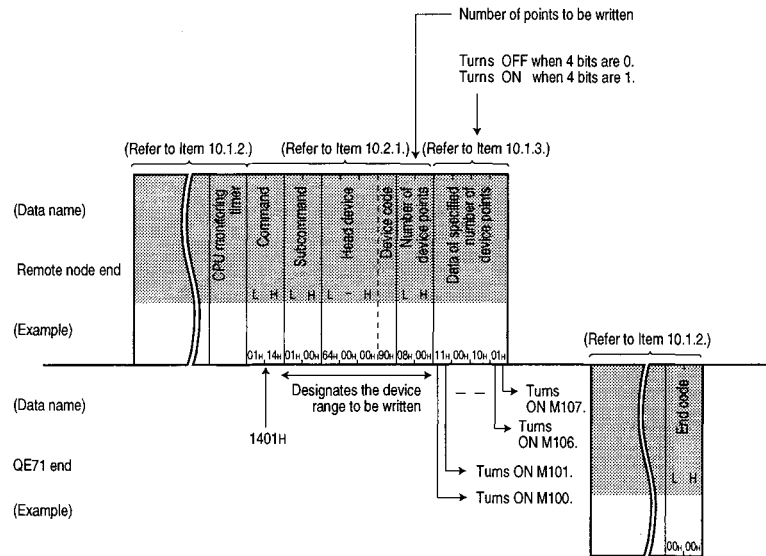

Point

- (1) Specify the number of device points within the following range.
 - ① When accessing the QnACPU access via the QE71 installed station QnACPU or MELSECNET/10
 - Number of device points $1 \leq \text{number of device points} \leq 1792 \text{ or } 3584$
ASCII code : 1792 points, binary code : 3584 points
 - Access range $(\text{Head device No.} + \text{number of device points} - 1) \leq \text{maximum device No.}$
 - ② When accessing other than ① above
 - Number of device points $1 \leq \text{number of device points} \leq 160$
 - Access range $(\text{Head device No.} + \text{number of device points} - 1) \leq \text{maximum device No.}$
- (2) When writing to the QnACPU, and the QnACPU's system protect is applied (system protect switch SW05 is on), an error will occur and end code will be returned during error.

10.2.5 Word Units Batch Write (Command : 1401)

This section explains the control procedure for batch writing to the bit device memory (16 bit unit) and word device memory (1 word unit) using an example.

(Control procedure)

1 When writing to the bit device memories

- (a) When writing the 2 point portion (32 bit portion) to the internal relays M100 to M131 during ASCII code exchange

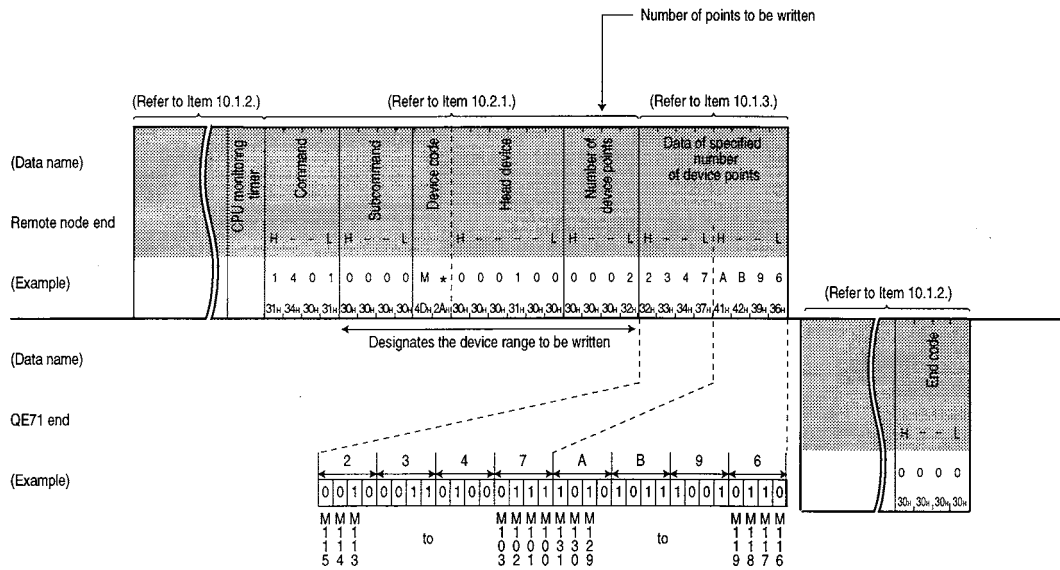

- (b) When writing the 2 point portion (32 bit portion) from the internal relays M100 to M131 using binary code exchange

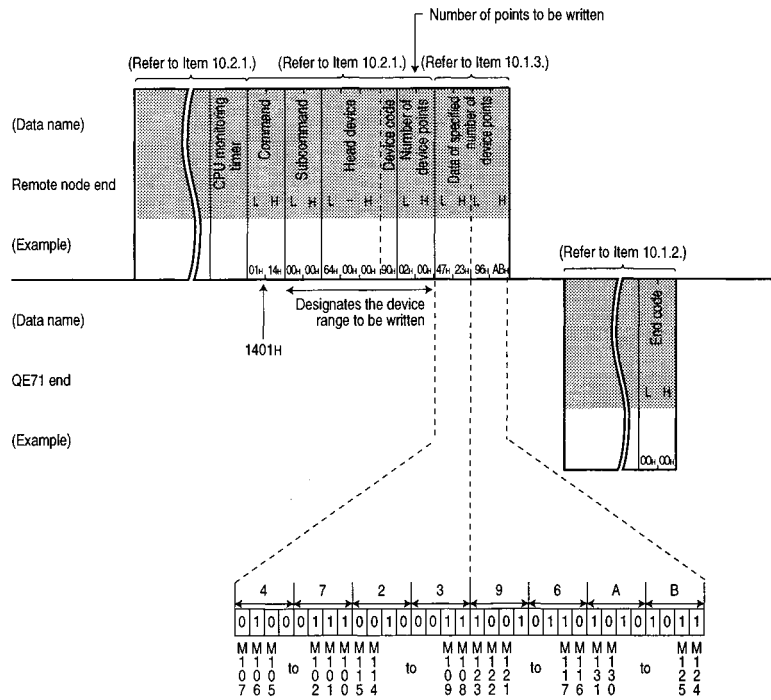

Point

- (1) Specify the number of device points within the following range.
The bit device is divided into 16 bits per one point.
 - ① When accessing the QnACPU via the QE71 installed station QnACPU or the MELSECNET/10
 - Number of device points $1 \leq \text{number of device points} \leq 480$... (480 words = 7680 bits)
 - Access range (Head device No. + number of device points $\times 16 - 1$) \leq maximum device No.
 - ② When accessing other than ① above
 - Number of device points $1 \leq \text{number of device points} \leq 10$... (10 words = 160 bits)
 - Access range (Head device No. + number of device points $\times 16 - 1$) \leq maximum device No.
- (2) When accessing PLC CPU bit devices other than those in ① above, be sure to set the head device No. to multiples of 16 (for decimal 0, 16,...).
- (3) When writing to the QnACPU, and the QnACPU's system protect is applied (system protect switch SW05 is on), an error will occur and end code will be returned during error.

2

When writing to the word device memory

(a) When writing the 3 point portion to the D100 to D102 using ASCII code exchange

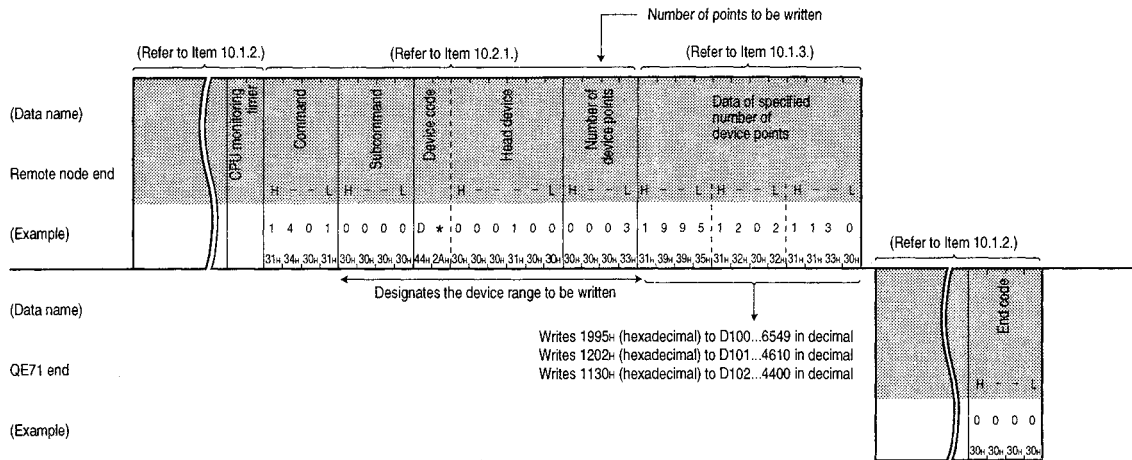

(b) When writing the 3 point portion to the D100 to D102 using binary code exchange

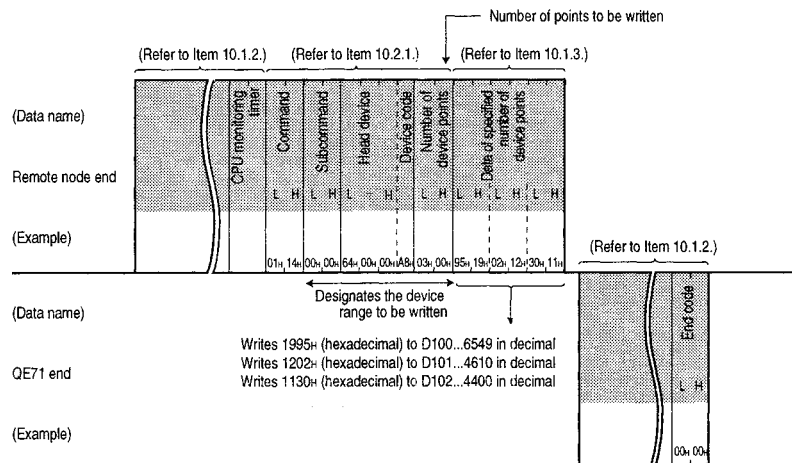

Point

- (1) Specify the number of device points within the following range.
 - ① When accessing the QnACPU via the QE71 installed station QnACPU or the MELSECNET/10
 - Number of device points $1 \leq \text{number of device points} \leq 480$
 - Access range $(\text{Head device No.} + \text{number of device points} - 1) \leq \text{maximum device No.}$
 - ② When accessing other than ① above
 - Number of device points $1 \leq \text{number of device points} \leq 64$
 - Access range $(\text{Head device No.} + \text{number of device points} - 1) \leq \text{maximum device No.}$
- (2) When writing to the QnACPU, and the QnACPU's system protect is applied (system protect switch SW5 is on), an error will occur and end code will be returned during error.

10.2.6 Word Units Random Read (Command : 0403)

This section explains the data read control procedure for setting the bit device memory (16/32 bit unit) and word device memory (1/2 word units) using an example.

The following read conditions (hereafter abbreviated as monitor conditions) that become the data read timing can be set as word unit random read. (Combine specification is possible)

- The device memory is read during PLC CPU's END processing when the specified bit device memory is on or off.
- The device memory when the specified word device memory value is the monitor condition's value, is read during PLC CPU's END processing. (The mask value can be set as the monitor condition values.)
- The device memory when the specified file specification step is executed, is read during the PLC CPU's END processing. (MELSAP3's block No. and step No. can also be specified.)

The device memory read timing using the monitor condition specifications is as follows.

Monitor conditions are not specified

The device memory is read when END processing is conducted when the QE71 sends a read request to the PLC CPU.

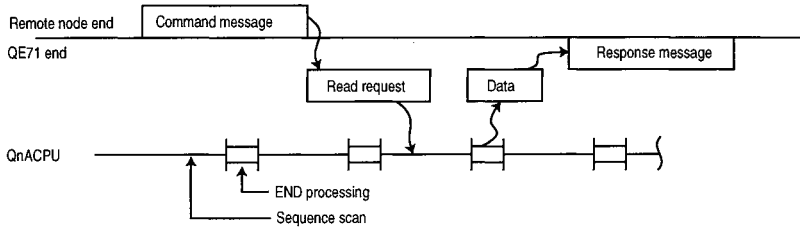

Monitor conditions are specified

The device memory is read when END processing is conducted at the time the user specified monitor conditions above are concluded set up after the QE71 has sent a read request to the PLC CPU.

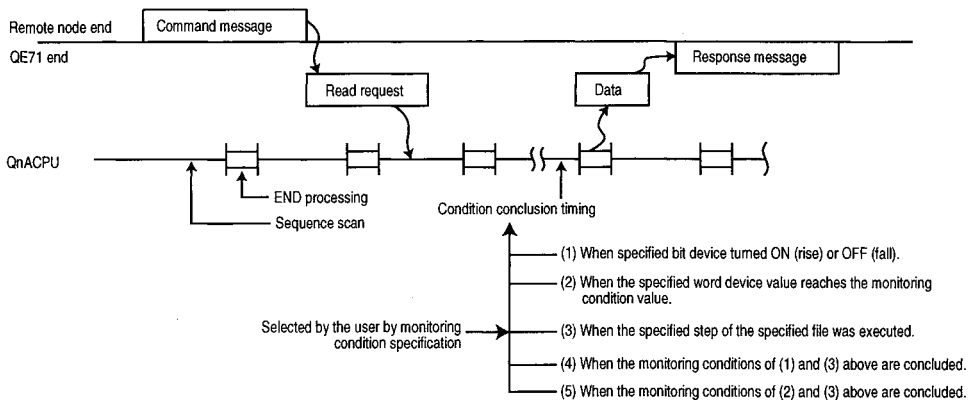

Point

Monitor is with conditions from special function modules and GPP cannot be conducted simultaneously for 1 QnACPU device memory.

When the following command message is transmitted from the remote node to the QE71, and other special function modules and GPP are conducting monitors with conditions for the same QnACPU, the QE71 will return an error end code to the remote node. (When monitoring without conditions is conducted, monitoring with conditions/without conditions from the QE71 can be conducted.)

Command	Function	Function explanation item
0403	Word unit random read function	This item
0802	Registration device memory monitor function	Item 10.2.9 4

1 Character area data order and contents during random read

This section explains about the character portion data order and contents during random read. The character portion differs partially from the order used by other commands.

(a) Character area data order when monitor conditions are not specified

① Data order for ASCII code

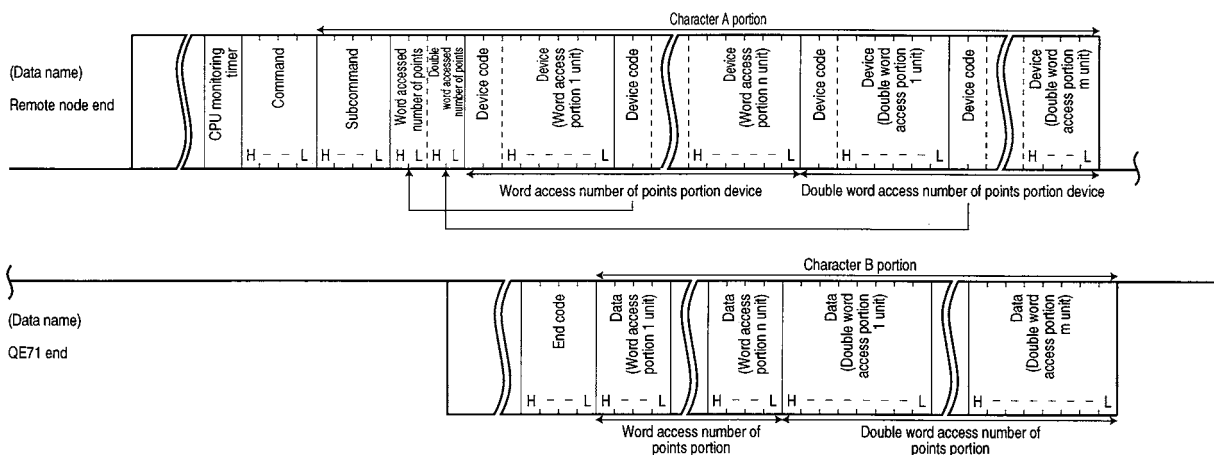

② Data order for binary code

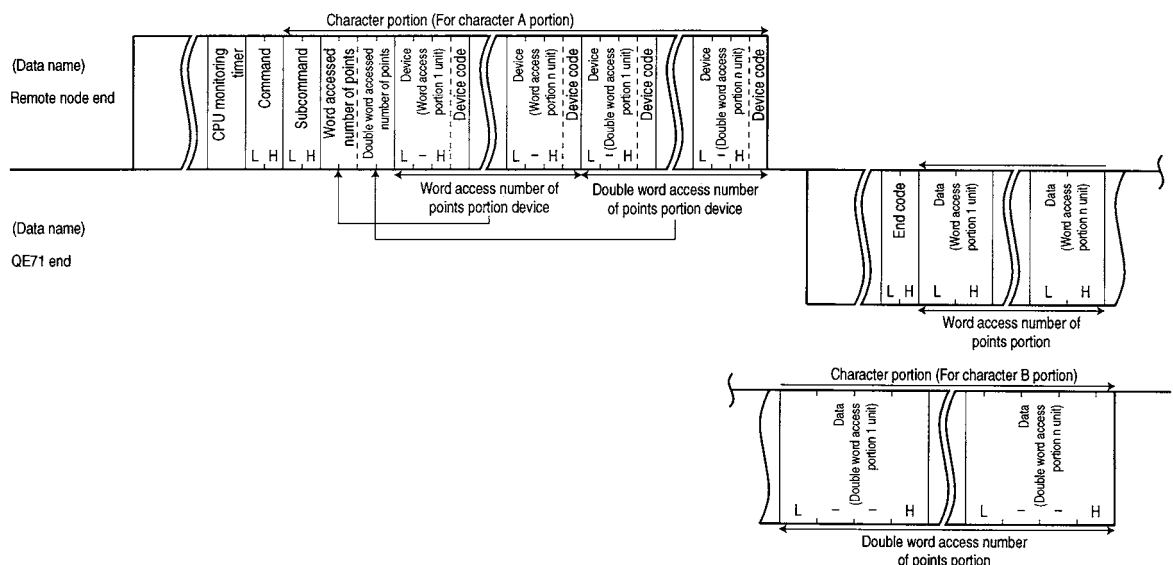

(b) Character area data order when monitor conditions are set

① Data order for ASCII code

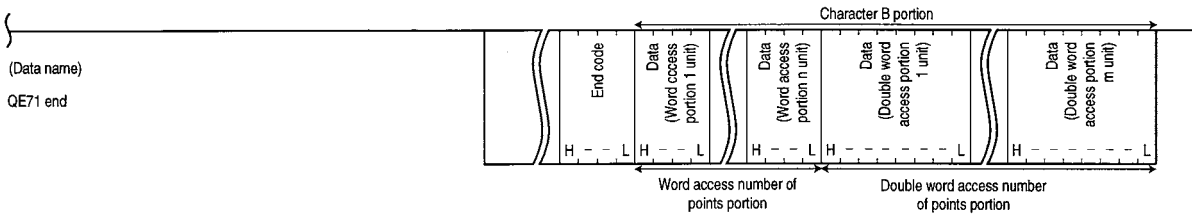
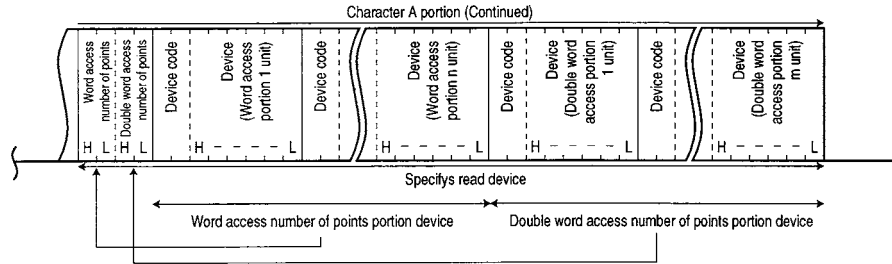
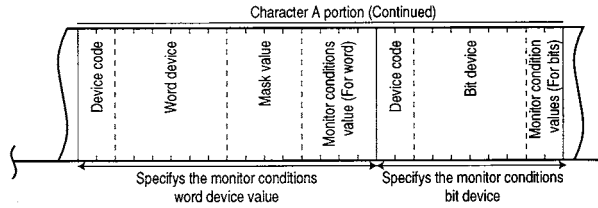
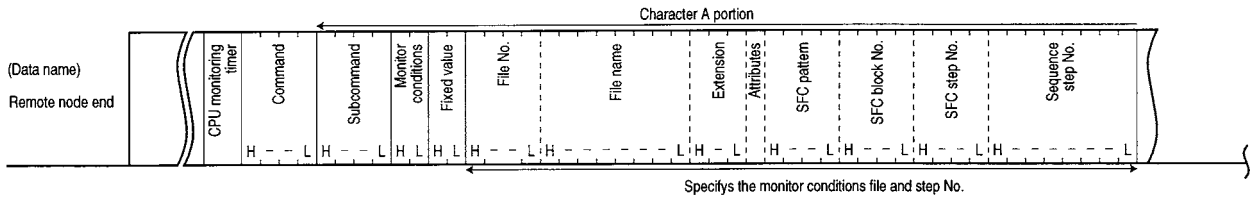

② Data order for binary code

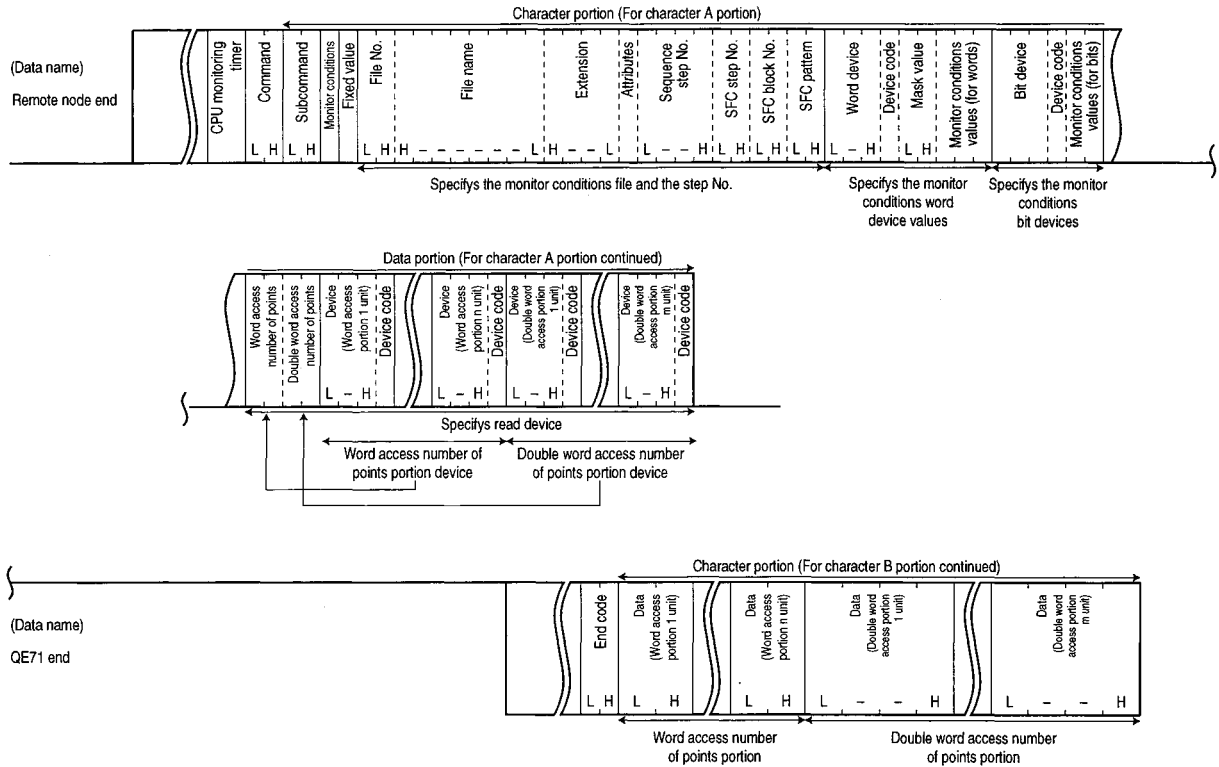

(c) Character area contents

For other than the data shown below, the contents used for other commands are the same.

① Subcommand

This data specifies the read/write units, type of device being specified, and data read conditions (timing), etc.

(a) For data exchange using ASCII code

Convert 0000H (0) and the following number to 4 digit ASCII code (hexadecimal number) and transmit it starting with the first digit.

(b) For data exchange using binary code

Use 0000H and the following 2 byte number and transmit.

(c) The subcommand specified contents are as follows.

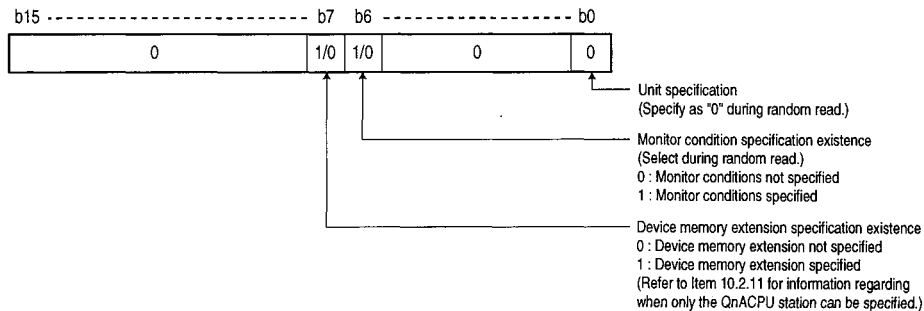

(d) The subcommand becomes "0000H" when monitor conditions not specified or device memory extension not specified are selected.

Remarks

The data for which specification is required after subcommand monitor condition specification existence are shown below.

Condition specification Data name	When monitor conditions not specified	When monitor conditions specified		
		When file and step No. specified	When word device specified	When bit device specified
Word access number of points			●	
Double word access number of points			●	
(For read device specification)	_____	_____	_____	_____
(For word read)			●	
Device code			●	
Device	(However, specification is not required when the word access number of points is 0 points.)			
(For double word read)	_____	_____	_____	_____
Device code			●	
Device	(However, specification is not required when the double word access number of points is 0 points.)			
Monitor conditions			●	
Fixed values	×		●	
File No. to Attributes	×	●	△	△
SFC pattern to SFC step No.	×	△	△	△
Sequence step No.	×	●	△	△
(For word device value specification)	_____	_____	_____	_____
Device code to Monitor condition values (For word)	×	△	●	△
(For bit device specification)	_____	_____	_____	_____
Device code to Monitor condition values (For bit)	×	△	△	●

● : Specification required △ : Selection (Specify the fixed values when unspecified)
 × : Specification not required

② Word access number of points and double word access number of points

This data is used to specify the read number of points using word units and the read number of points using double word units. The total for each number of points must be specified within the processing number of points conducted during one exchange as shown in the table in Item 10.2.1 1.

(a) For data exchange using ASCII code

Each number of points is converted to ASCII code 2 digits (hexadecimal) and transmitted.

(Example) For 5 points Becomes "05" and is transmitted in order from "0."
 For 20 points .. Becomes "14" and is transmitted in order from "1."

(b) For data exchange using binary code

The 1 byte numerical value that shows the number of points is transmitted.

(Example) For 5 points 05H is transmitted.
 For 20 points .. 14H is transmitted.

(c) When 0 points is specified for either access number of points, it is not necessary to specify the device or device code that reads data.

③ Monitor conditions

This data is used to specify the data read conditions and can only be specified for the QnACPU.

The monitor condition combinations that can be specified are shown below. (3 conditions cannot be specified at the same time.)

Combination \ Monitor condition	File and step No. specification	Word device value specification	Bit device specification
Single specification	○	○	○
Combination specification	○	○	
	○		○

○ : Specification possible

(a) For data exchange using ASCII code

The following numerical values are converted to ASCII code 2 digits (hexadecimal) and transmitted from the first digit.

(b) For data exchange using binary code

The following 1 byte numerical values are transmitted.

(c) The monitor conditions specification contents are shown below.

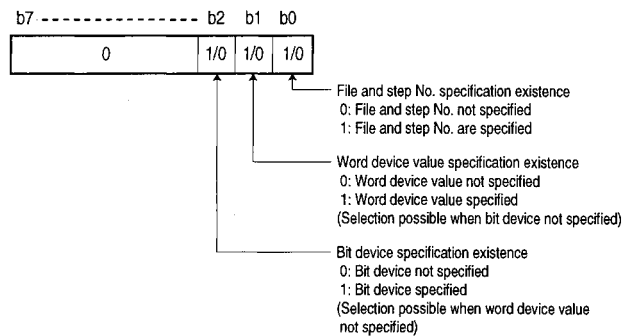

(d) The monitor conditions change to "01H" to "05H" when monitor conditions are specified is selected using subcommands.

"00H" cannot be used.

(e) The monitor condition specification is not required when monitor condition not specified is selected using the subcommand.

④ Fixed value

(a) Data exchange using ASCII code

The "0F" is transmitted from the first digit (0).

(b) For data exchange using binary code

The 1 byte numerical value "0FH" is transmitted.

(c) Specifying the fixed value is not required when monitor condition not specified is selected using the subcommand.

⑤ File No.

This data is used to specify the registration No. when the file specified using the following file names and extensions are registered (written) to the PLC CPU and one of the following is specified.

File No.	Contents	Specification contents
0000H	File name not specified	Specify when the file and step No. not specified are selected using the monitor conditions.
0001H to 0100H	File No.	Specify when the file No. is known.
FFFFH	File No. unknown	Specify when the file No. is searched for in the QE71. (The random read request from the QE71 to the PLC CPU is delayed more than 1 sequence scan time.)

- (a) For data exchange using ASCII code
The above file No. is converted into ASCII code 4 digits (hexadecimal) and transmitted.
(Example) For 1FH becomes "001F" and is transmitted in order from "0."
- (b) For data exchange using binary code
The above 2 byte numerical value is transmitted.
(Example) For 1FH becomes 001FH and is transmitted in order from 1FH, 00H.
- (c) Even when monitor condition is specified or selected using the subcommand, the file No. will become 0000H when the file and the step No. without specification is selected (using 02H, 04H) at the monitor conditions.
- (d) It is not necessary to specify the file No. when monitor conditions not specified is selected at subcommands.
- (e) The file No. can be checked using the file existence read function described in Item 10.6.6.

⑥ File name, Extension, Attributes

Specifies the file name, extension, and attribute of the subject file in ⑨ (data for specifying the sequence step No.'s subject file) is registered (written) to the PLC CPU. The user created file attributes are initially 20H (disk file), and this attribute can be changed by the user. (Refer to Item 10.6.5)

- (a) For data exchange using ASCII code
The registration time's file name, extension, and attribute are all transmitted from the first character. The attribute is transmitted blank (code : 20H).
When the file name is less than 8 characters, a blank (code : 20H) is added.
(Example) When the register time's file name is "ABCD12"
becomes "ABCD12 _ _ _ , " and is transmitted in order from "A."
- (b) For data exchange using binary code
The file name and extension are transmitted in order from the first character as the binary value for each character code.
The attribute is transmitted as the 1 byte numerical value "20H."
If the file name is less than 8 characters then 20H is added.
(Example) When the register time's file name is "ABCD12"
becomes 41H, 42H, 43H, 44H, 31H, 32H, 20H, 20H, and is transmitted in order from 41H.
- (c) The file name and extension will become the order of blank or 20H when file and step No. not specified is selected (using 02H, 04H) at the monitor conditions, even though monitor conditions specified was selected using the subcommand. The attribute becomes blank or 20H.

- (d) Specifying the file name, extension, and attribute is not necessary when monitor conditions not specified is selected using the subcommand.
- (e) The attribute can be checked using the file existence read function described in Item 10.6.6.

⑦ SFC Pattern

This is one of the data used during the execution of the sequence step No. specified by the MELSAP3 program (hereafter abbreviated to SFC) as the read timing for the data.

- (a) The following data is specified by the SFC pattern when monitor conditions specified is selected using a subcommand and file and step No. specified is selected at “③ monitor conditions.”

That other than the following cannot be specified.

Mode	Write data	Remarks
ASCII code	When SFC specified	"0003"
	When SFC not specified	"0000"
Binary code	When SFC specified	0003H
	When SFC not specified	0000H

- (b) The SFC pattern becomes “0000”/“0000H” when the file and step No. not specified is selected even though monitor condition specified is selected using the subcommands.
- (c) When the SFC pattern is specified using “0003”/“0003H”, the device memory data specified during the PLC CPU end processing that is conducted when the specified PLC step No. is executed in ⑨ for the block No. and step No. specified in ⑧ below is read.
- (d) Specifying the SFC pattern is not necessary when monitor condition not specified is selected using the subcommand.

Point

- (1) For details on MELSAP3, refer to the MELSAP3 programming manual (SFC) and operating manual.
- (2) The SFC block No. and SFC step No. specified in ⑧ and the sequence step No. specified in ⑨, correspond to the display shown below while editing an MELSAP3 program (The SFC block No. is displayed on the title bar when GPPW is used.)
(Example)

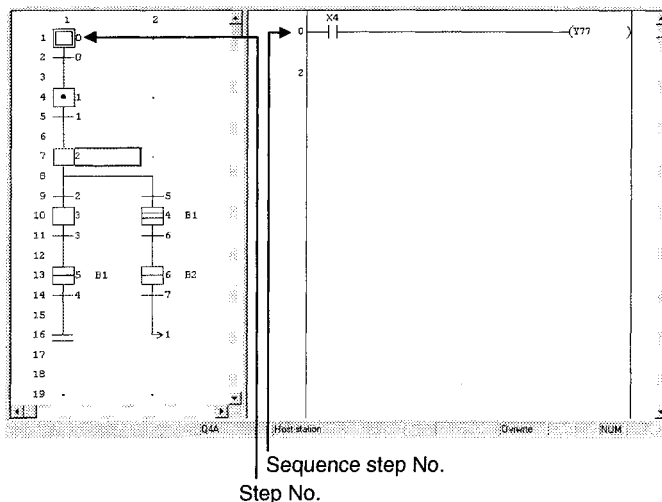

⑧ SFC block No. and SFC step No.

This data is used to specify the SFC block No. and SFC step No. including the sequence step that it will become the data read timing (when the specified sequence step is executed). This data can be specified when monitor conditions specified is selected using the subcommand, file and file No. specified are selected using monitor conditions, and SFC block specified is selected using the SFC pattern specification.

(a) For data exchange using ASCII code

The following numerical value is converted into ASCII code 4 digits (hexadecimal) and transmitted from the first character (0).

- SFC block No. 0000H to 013FH (0 to 319)
- SFC step No. 0000H to 01FFH (0 to 511)

(b) For data exchange using binary code

The above 2 byte numerical value is transmitted.

(Example) For 0005H Transmitted in order from 05H, 00H.

(c) In the following cases, both the SFC block No. and SFC step No. become 0000H.

- When the file and step No. not specified was selected with monitor conditions even though the monitor condition specified was selected with subcommand.
- When the SFC block No. not specified was selected using the SFC pattern.

(d) The SFC block No. and SFC step No. do not need to be specified when the monitor condition not specified is selected using subcommand.

⑨ Sequence step No.

This data is for specifying the sequence program step No. that will become the data read timing (when the specified sequence step is executed), the pointer (P) No. and the interrupt point (I) No.

The sequence step No. can be specified when the monitor condition specified is selected using the subcommand and the file and step No. specified is selected using the monitor condition.

(a) For data exchange using ASCII code

The following numerical values from the range existing in the subject file are converted to ASCII code 8 digits (hexadecimal) and transmitted from the first digit.

(b) For data exchange using binary code

The following 4 byte numerical values that are in the range existing in the subject file are transmitted.

(Example) 00000005H ... The transmission is conducted in order from 05H.

(c) The sequence step No.'s specification contents are as follows.

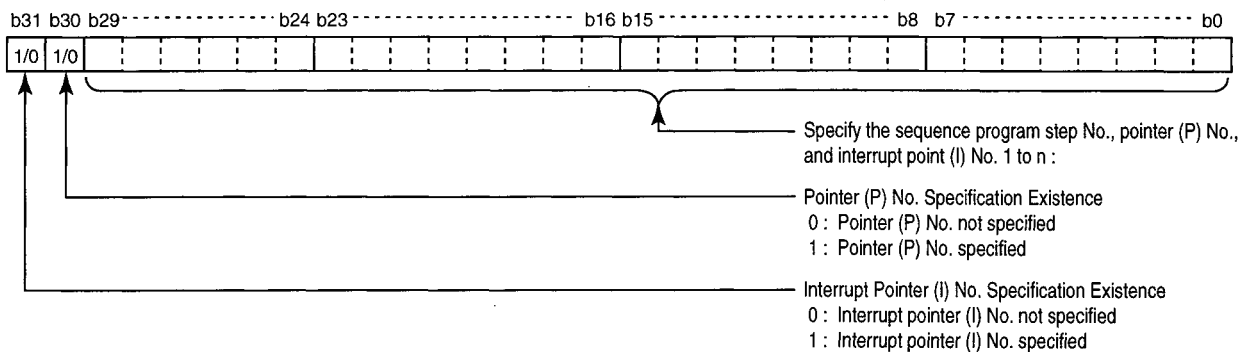

(Example) Becomes 0000001CH when the sequence program step No. 28 is specified becomes 8000001CH when the interrupt point I28 is specified.

- (d) The sequence step No. becomes 00000000H when the file and step No. not specified is selected using the monitor conditions even though the monitor condition specified is selected using the subcommand.
- (e) Specifying the sequence step No. is not required when the monitor condition without specification is selected using the subcommand.

⑩ Mask value and monitor conditions value (for words)

This data is used to specify the word device values that will become the data read timing (when the specified word device becomes the monitor condition value).

- Mask value

This data is used to extract the monitor condition word device free bit range value. (Performs the same operation as the sequence program's WAND command.)

- Monitor conditions value (for words)

This data is used to specify the numerical value (monitor condition word device value and mask value logical calculation (same as WAND command) results) that will become the data read timing.

(Example) When the monitor condition D0 bits 0 to 14 extraction results become 3E8H (1000), specify the data read timing as shown below.

Mask value : 7FFFH

Monitor conditions value (for words) : 03E8H

The mask value and monitor conditions value (for words) can be set when the monitor conditions specified are selected using the subcommand and the word device value specified is selected using the monitor conditions.

- (a) For data exchange using ASCII code

The above mask values and monitor condition values are converted to ASCII code 4 digits (hexadecimal) and transmitted from the first digit.

- (b) For data exchange using binary code

The 2 byte numerical values shown in the above mask values and monitor condition values is transmitted.

(Example) For 0005H Transmitted in order from 05H.

- (c) The mask values and monitor conditions values become blank order or 0000H when the word device value not specified is selected using the monitor conditions even though the monitor conditions specified selected using the subcommand.

In this case, the word device and device code are specified in the free word device memory and its device code in order to specify the monitor conditions word device value.

- (d) The mask value and monitor conditions values do not need to be specified when monitor conditions not specified is selected using a subcommand.

(It is not necessary to specify the word device and device code for the specification of the monitor condition's word device values.)

⑪ Monitor conditions values (for bits)

The monitor conditions value (for bits) is that data is used to specify the conditions (boot up, shut down) that will become the data read timing.

The monitor conditions values (for bits) can be specified when the monitor condition specified are selected using the subcommand and the bit device specify is selected using the monitor conditions.

(a) For data exchange using ASCII code

The following numerical values are converted to ASCII code 2 digits (hexadecimal) and transmitted from the first digit (0).

(b) For data exchange using binary code

The following 1 byte numerical value is transmitted.

(c) The monitor conditions values (for bits) specification contents are shown below.

Specification value	Read timing
02H	During the PLC CPU's END processing when the specified bit device is booted up.
04H	During the PLC CPU's END processing when the specified bit device is shut down.

(d) The monitor condition value becomes "00" or "00H" when the bit device not specified is selected using the monitor conditions, even though the monitor condition specified is selected using the subcommand.

In this case, the free bit device memory and its device code are specified for the bit device and device code that are used to specify the monitor condition bit device.

(e) Specifying the monitor conditions values is not required when the monitor condition not specified is selected using the subcommand.

(Selecting the bit device code for specifying the monitor condition's bit device is not required.)

(b) For device memory read using binary code

- Word access : D0, T0, M100 to M115, X10 to X1F
- Double word access : D1500 to D1501, Y160 to Y17F, M111 to M114Z

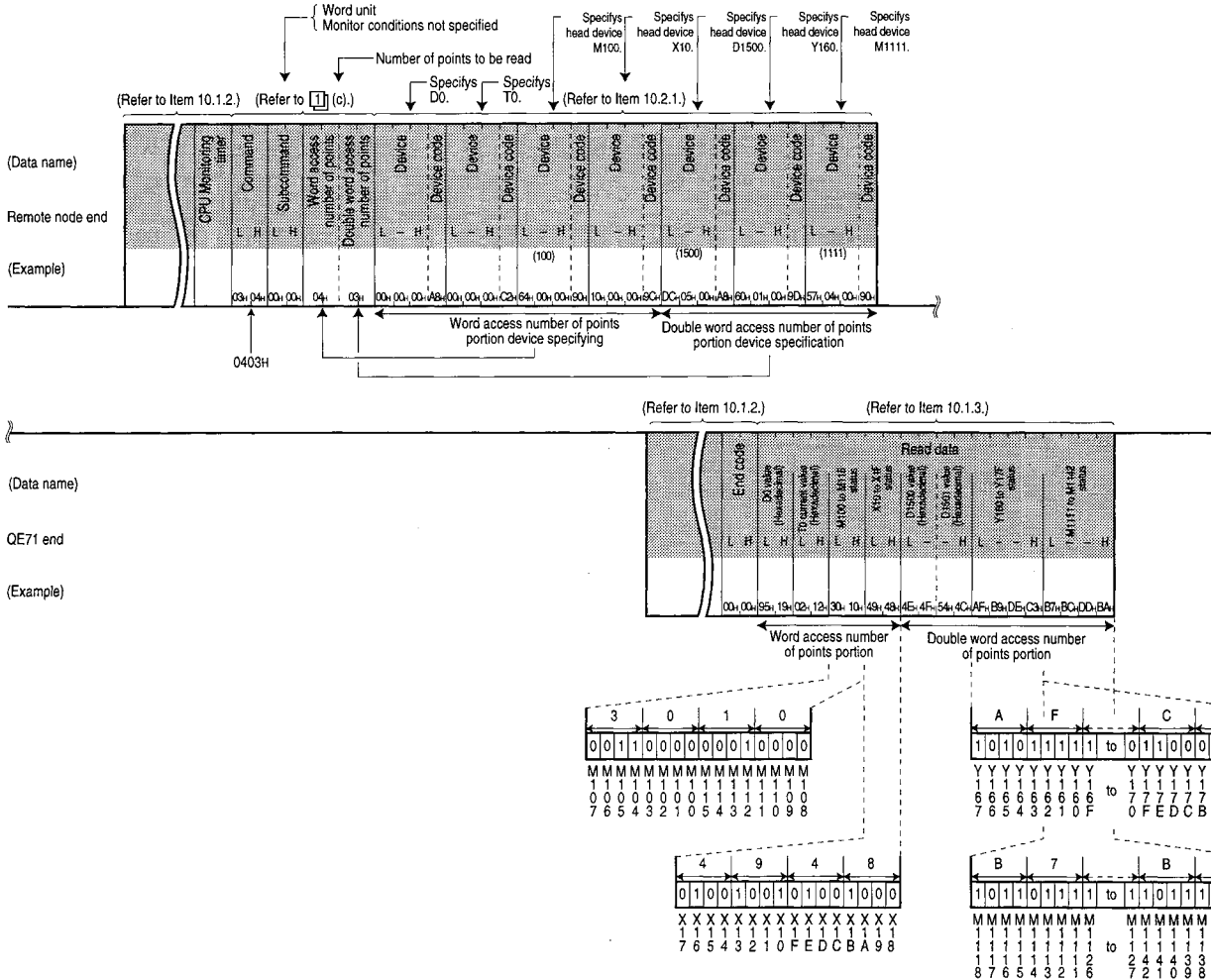

Point

(1) Specify the number of access points within the following range. (The same as when setting the monitor conditions.)

For the bit device, when word access divide into 16 bits per point and when double word access divide into 32 bits per point.

For the word device, when word access divide into 1 word per point, and when double word access divide into 2 words per point.

① When accessing the QnACPU via the QE71 installed station QnACPU and MELSECNET/10

- Access number of points $1 \leq (\text{word access number of points} + \text{double word access number of points}) \leq 96$

② When accessing other than ① above

- Access number of points $1 \leq (\text{word access number of points}) \leq 10$

(2) When accessing a PLC CPU bit device other than ① above, be sure to make the device No. multiples of 16 (for decimal : 0, 16, ...).

(b) When the following contents are randomly read using binary code

① Monitor conditions

The link register W100's value becomes 7BH (123) when the program file CONB1.QPG's step No. 1000 is executed.

② Read device memory

- Word access : D0, T0, M100 to M115, X10 to X1F
- Double word access : D1500 to D1501, Y160 to Y17F, M1111 to M114Z

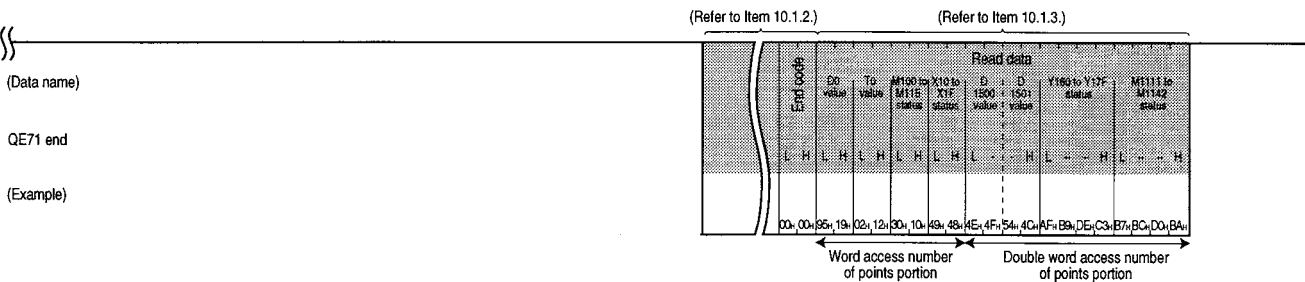
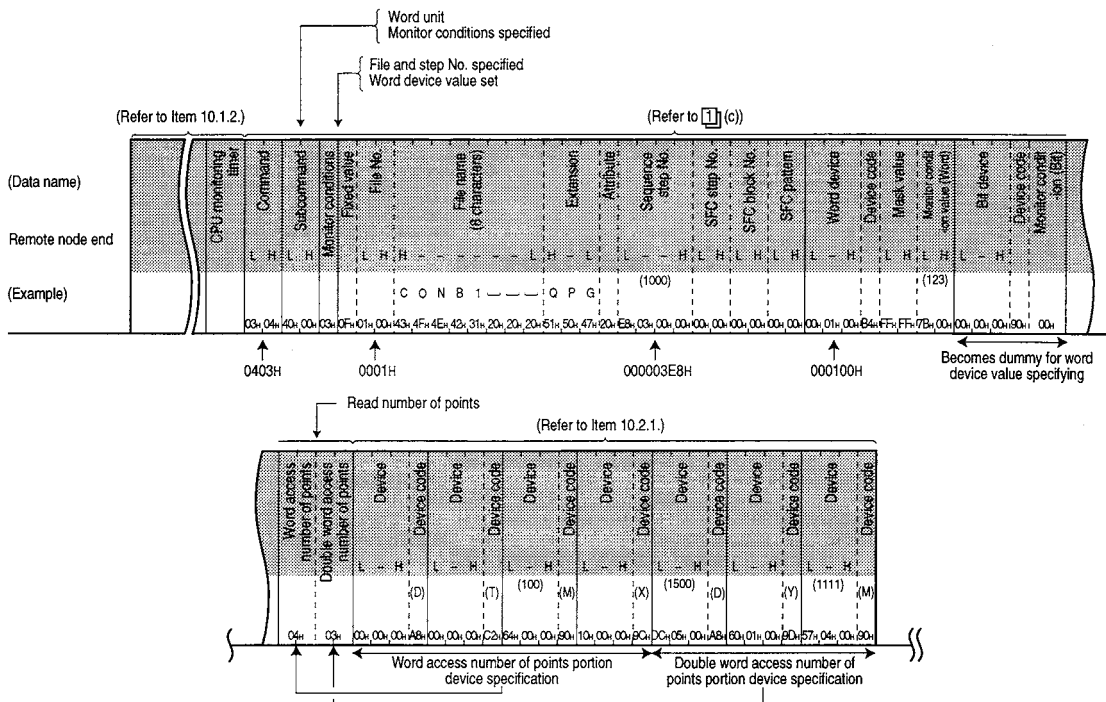

Point

- (1) Specify the number of access points in the following range. (The same as when monitor conditions are not specified.)
 For the bit device, divide into 16 bits per point for word access and 32 bits per point for double word access.
 For the word device, divide into 1 word per 1 point for word access and 2 words per point for double point access.
 - ① When accessing the QnACPU via the QE71 installed station QnACPU and MELSECNET/10
 - Access number of points $1 \leq (\text{word access number of points} + \text{double word access number of points}) \leq 96$
 - ② When accessing other than ① above
 - Access number of points $1 \leq (\text{word access number of points}) \leq 10$
- (2) When accessing the PLC CPU bit device other than that above in ①, be sure to set the device No. in multiples of 16 (for decimal: 0, 16, ...).

10.2.7 Bit Units Random Write (Test) (Command : 1402)

This section uses an example to explain the data write control procedure when the bit device memory is randomly specified.

(Control procedure)

(a) When the internal relay M50 is OFF and the output relay Y2F is ON during ASCII code exchange

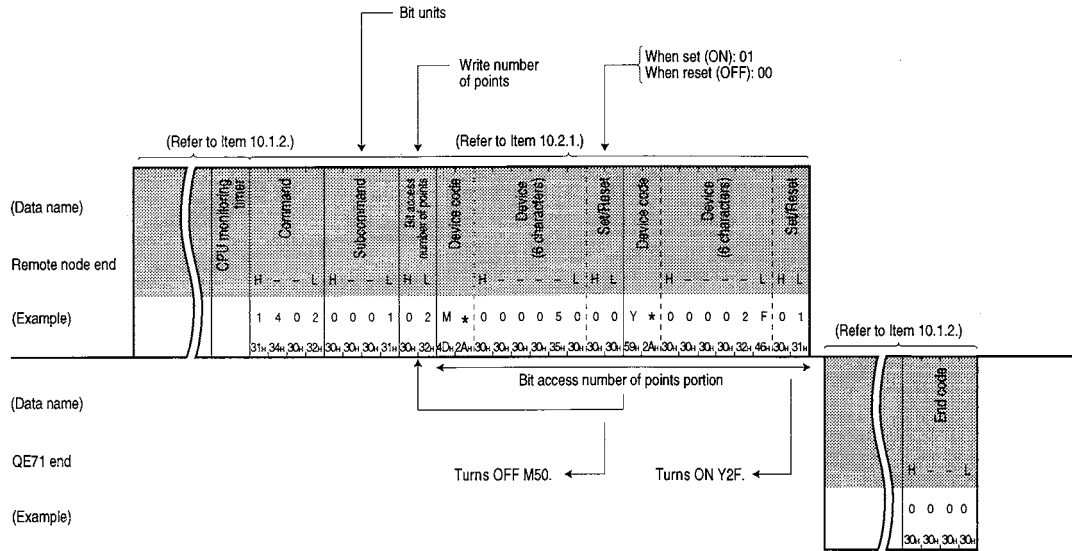

(b) When the internal relay M50 is OFF and the output relay Y2F is ON during binary code exchange

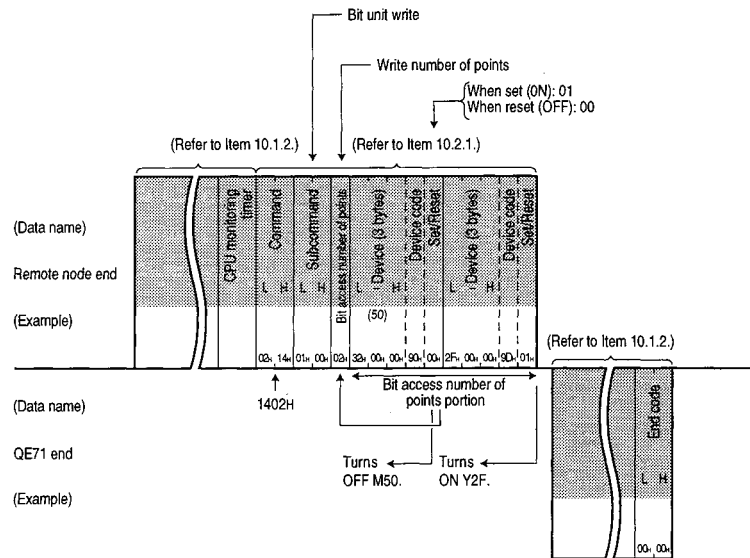

Point

- (1) Specify the number of access points in the following range.
 - ① When accessing QnACPU via the QE71 installed station QnACPU and MELSECNET/10
 - Access number of points 1 ≤ access number of points ≤ 94
 - ② When accessing other than ① above
 - Access number of points 1 ≤ access number of points ≤ 20
- (2) When writing to the QnACPU, if a system protect is applied to the QnACPU (system protect switch SW5 is on), an error will occur and an end code will be returned during error.

10.2.8 Word Units Random Write (Test) (Command : 1402)

This section uses an example to explain the data write control procedure when the bit device memory (16/32 bit unit) and the word device memory (1/2 word unit) are randomly specified.

(Control procedure)

(a) When writing to the following device memory during ASCII code exchange

- Word access : D0, D1, M100 to M115, X10 to X1F
- Double word access : D150 to D1501, Y160 to Y17F, M1111 to M1142

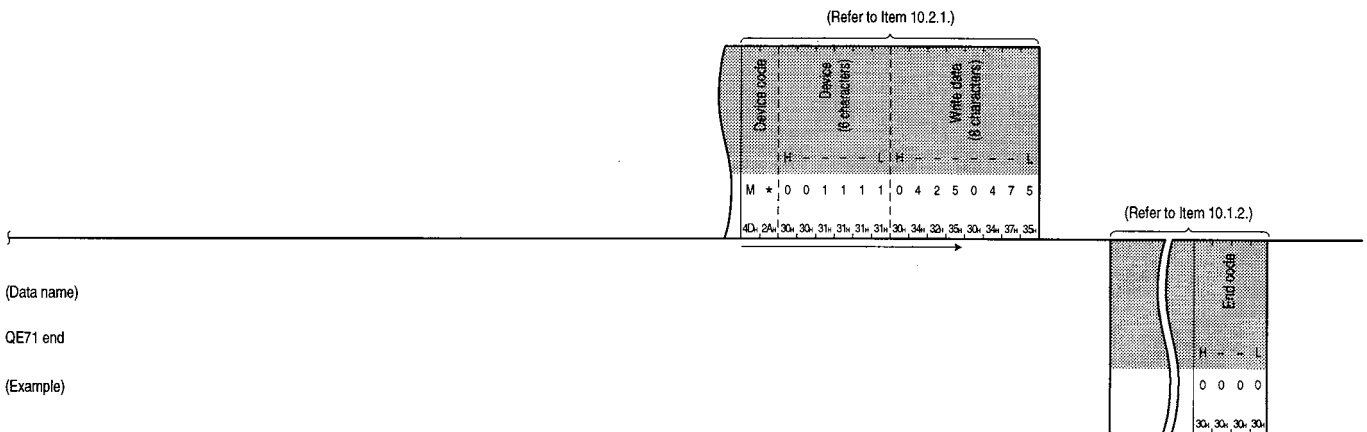
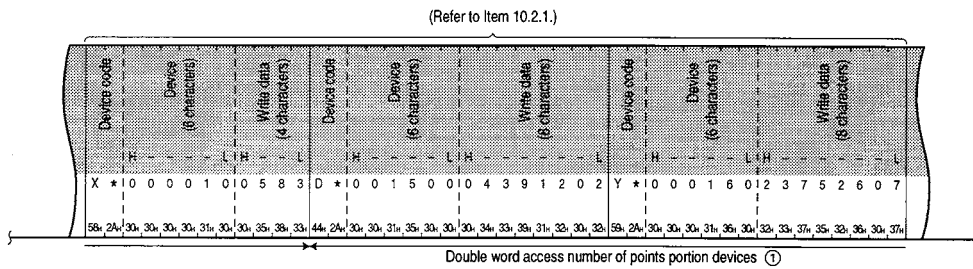
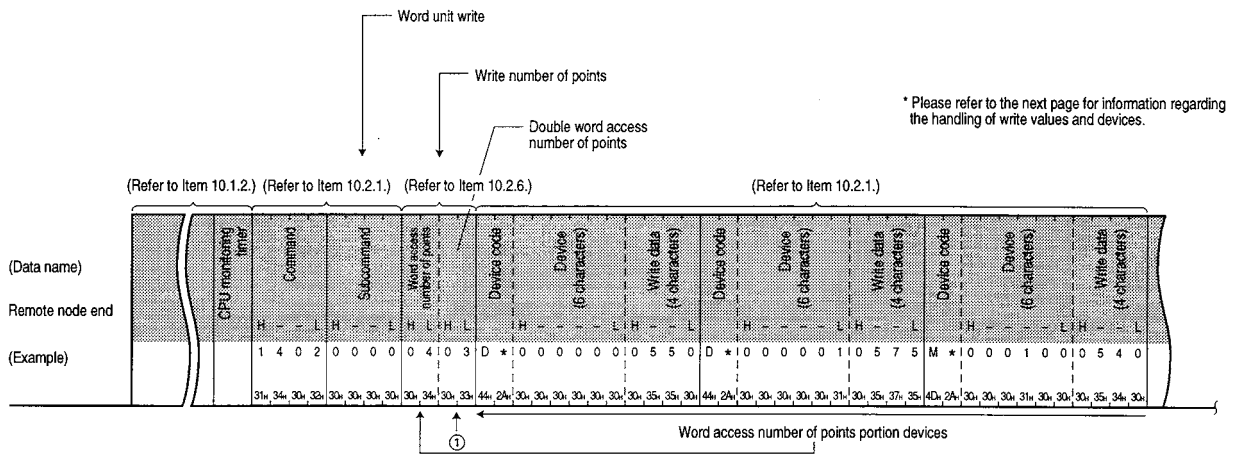

(b) When writing to the following device memory during binary code exchange

- Word access : D0, D1, M100 to M115, X10 to X1F
- Double word access : D1500 to D1501, Y160 to Y17F, M1111 to M1142

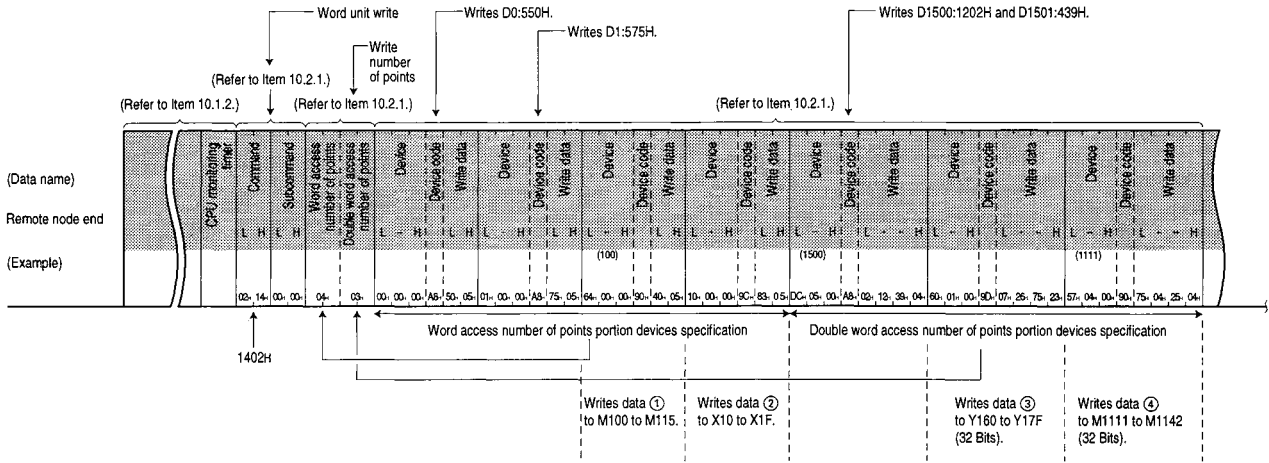

Writes data ① to M100 to M115.
Writes data ② to X10 to X1F.
Writes data ③ to Y160 to Y17F (32 Bits).
Writes data ④ to M1111 to M1142 (32 Bits).

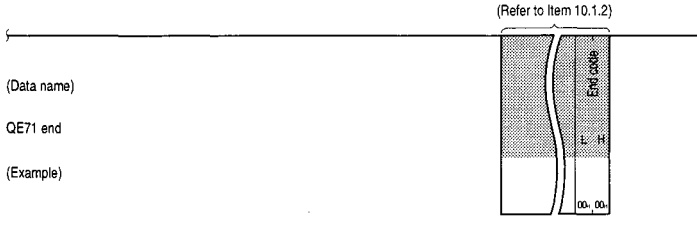
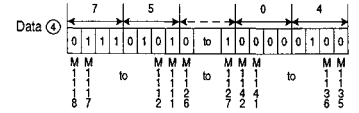
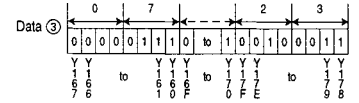
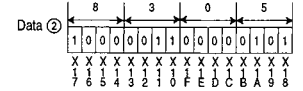
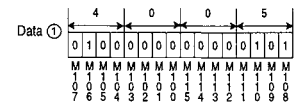

Point

- Specify the number of access points in the following range.
For the bit device, divide it into 16 bits per point for word access and 32 bits per point for double word access.
For the word device, divide it into 1 word per point for word access and 2 words per point for double word access.
 - When accessing a QnACPU via the QE71's installed station QnACPU and MELSECNET/10
Access number of points $1 \leq (\text{word access number of points} \times 12 + \text{double word access number of points} \times 14) \leq 960$
 - When accessing other than ① above
Access number of points $1 \leq (\text{word access number of points}) \leq 10$
- When accessing PLC CPU bit devices other than those in ① above, be sure to set the device No. in multiples of 16 (for decimal : 0, 16, ...).
- When writing to the QnACPU, if a system protect is applied to the QnACPU (system protect switch SW05 is on), then an error will occur and an end code will be returned during error.

10.2.9 Device Memory Monitor

Monitor data registration is the function that registers in the QE71 the device and No. to be monitored from the remote node.

In addition, the function that can read the data contents of the device registered in the monitor data using the PLC CPU and then process that using a remote node.

The device No. will be in sequence when read using the batch read function (Refer to Items 10.2.2 and 10.2.3), but using this function make it possible to randomly set the No. and conduct monitoring.

The following uses an example to explain the control procedures that will conduct monitoring and the control procedures for registering the device to be monitored and the No. in the QE71.

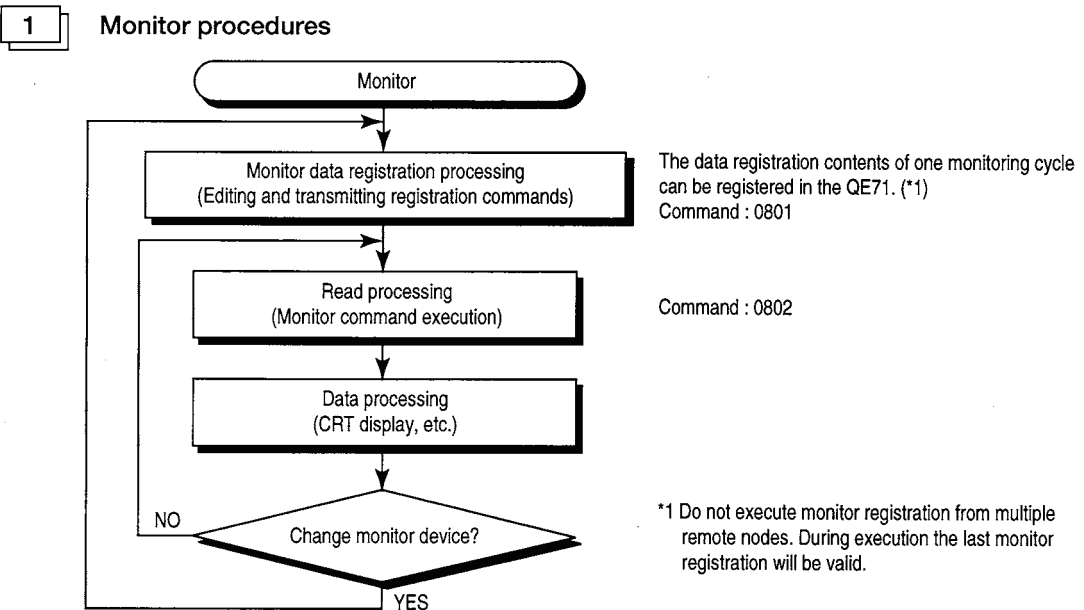

Point

- (1) The device memory monitor function can read data using the following method.
The specified method and the character portion's data contents in the control procedures and the monitoring (reading) timing of the data uses the same word unit random read function. For details, refer to Item 10.2.6
 - ① The bit device memories and word device memories can be mixed when specified.
 - ② The bit device memory can be read in 16/32 bit units and the word device memory can be read in 1/2 word units.
 - ③ The monitor conditions that become the data monitor (read) timing can be specified during monitor data registration.
(Specifying combinations of multiple conditions is possible.)
- (2) Monitor is with conditions from special function modules and GPP cannot be conducted simultaneously for 1 QnACPU device memory.
When the following command messages are transmitted to the QE71 from a remote node and monitor with conditions is performed by other equipment such as the special function module or the GPP to the same QnACPU, the QE71 will return an end code during error to the remote node. (If monitor without conditions is being conducted, monitor with conditions/without conditions can be conducted from the QE71.)

Command	Function	Function explanation item
0403	Word unit random read function	Item 10.2.6
0802	Registration device memory monitor function	This item 4

- (3) When executing monitor as with the above procedure, monitor data registration must be performed. If monitor is performed without registering monitor data, an end code will be returned when the error occurs.

2

Monitor data registration (Command : 0801) (Monitor conditions not specified)

This section uses an example to explain monitor data registration control procedures for monitoring device memory without monitor conditions (read conditions) by randomly specifying the bit device memory (16/32 bit unit) word device memory (1/2 word unit).

(Control procedure)

(a) When conducting monitor data registration for the following device memories using ASCII code

- Word access : D0, T0, M100 to M115, X10 to X1F
- Double word access : D1500 to D1501, Y160 to Y17F, M1111 to M1142

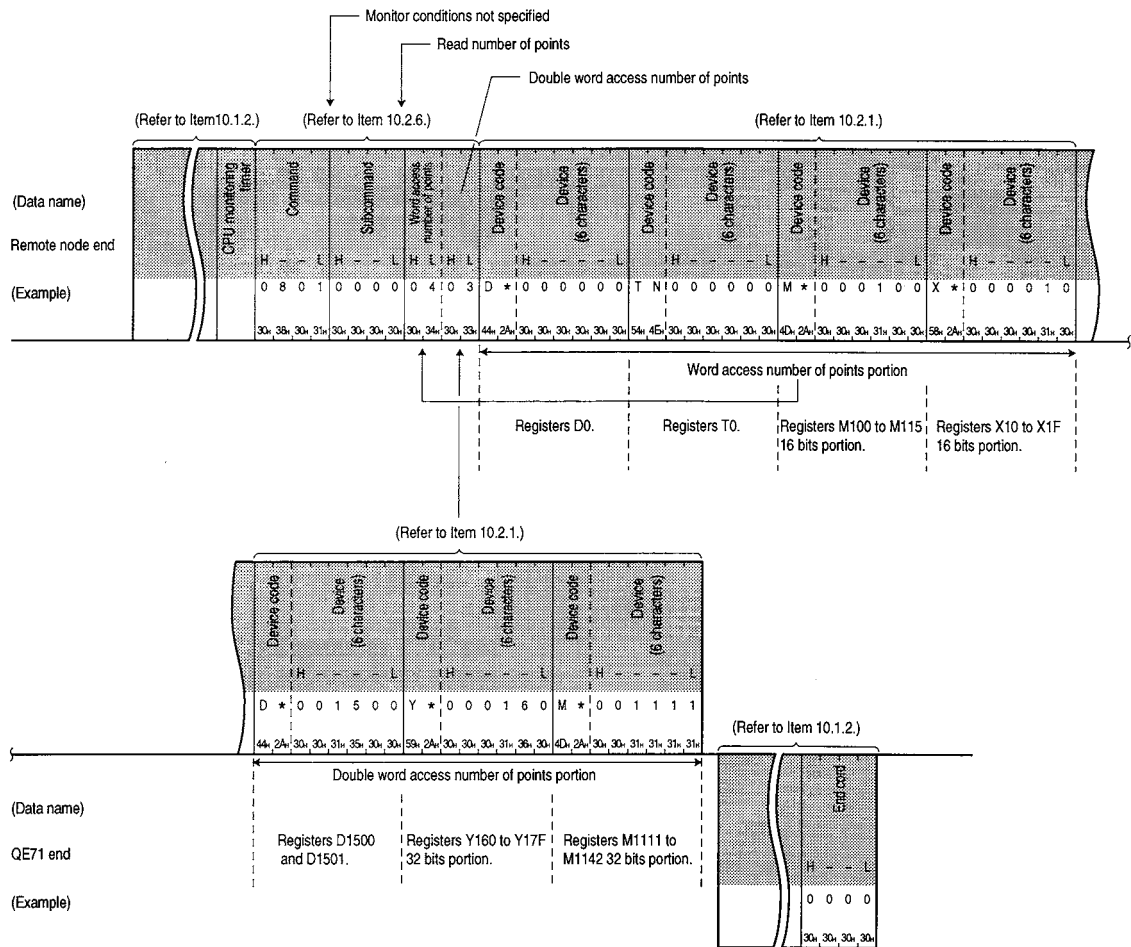

- (b) When conducting monitor data registration for the following device memories using binary code
- Word access : D0, T0, M100 to M115, X10 to X1F
 - Double word access : D1500 to D1501, Y160 to Y17F, M1111 to M1142

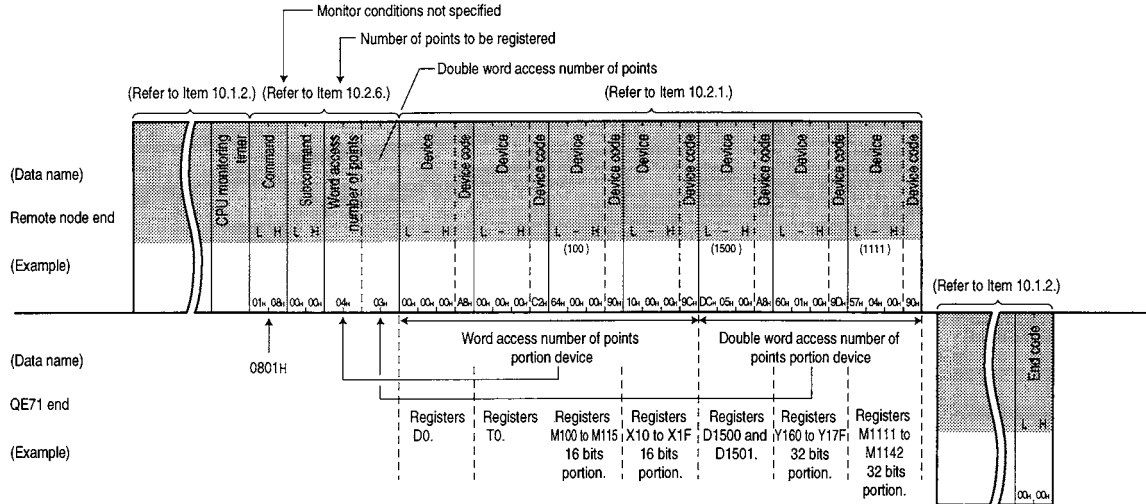

Point

(1) Set the number of access points in the following range. (The same as when specifying monitor conditions.)
 For bit devices it will be divided into 16 bits per point for word access and 32 bits per point for double word access.
 For word devices it will be divided into 1 word per 1 point for word access and 2 words per 1 point for double word access.

① When accessing the QnACPU via the QE71's installed station QnACPU and MELSECNET/10

- Access number of points $1 \leq (\text{word access number of points} + \text{double word access number of points}) \leq 96$

② When accessing other than that in ① above

- Cannot be accessed.

(2) When accessing a PLC CPU bit device other than those in ① above, the device No. must be set in multiples of 16 (for decimal : 0, 16, ...).

(3) When the following occurs, the data saved as monitor data in the QE71 by user will be deleted.

① Data saved as monitor data will be deleted, when the power for the QE71 installed station is turned off, or QnACPU is reset.

② Previous data saved as monitor data will be deleted, if monitor data registration is performed more than twice.

3 Monitor data registration (Command : 0801) (Monitor conditions specified)

This section uses an example to explain the monitor data registration control procedure for monitoring device memories by randomly specifying bit device memory (16/32 bit unit) and word device memory (1/2 word unit) and by specifying the monitor conditions (read conditions).

(Control procedure)

(a) When conducting monitor data registration using the following contents using ASCII code

① Monitor conditions

The link register W100 value becomes 7BH (123) when the program file CONB1.QPG sequence program step No. 1000 was executed.

② Device memory to conduct monitor (Read)

- Word access : D0, T0, M100 to M115, X10 to X1F
- Double word access : D1500 to D1501, Y160 to Y17F, M1111 to M1142

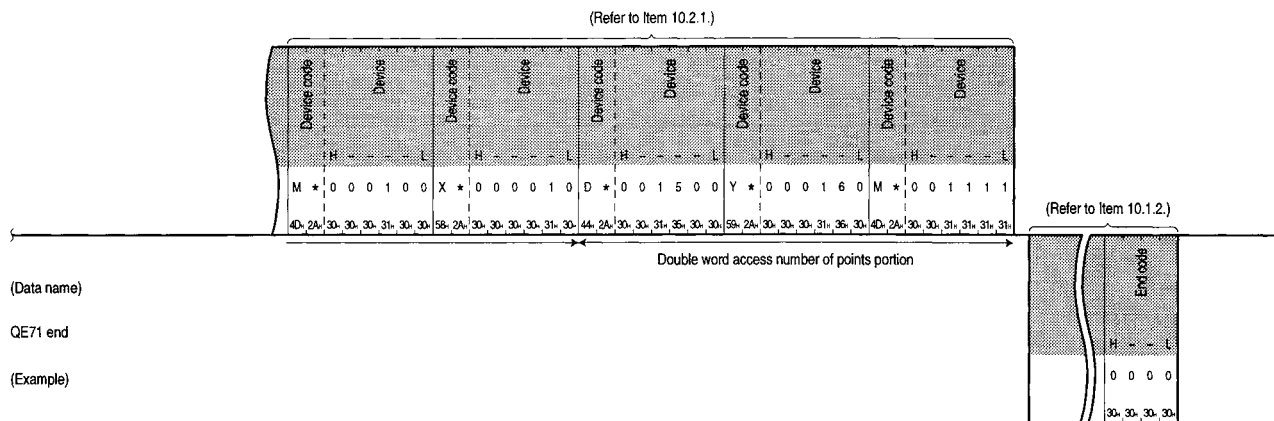
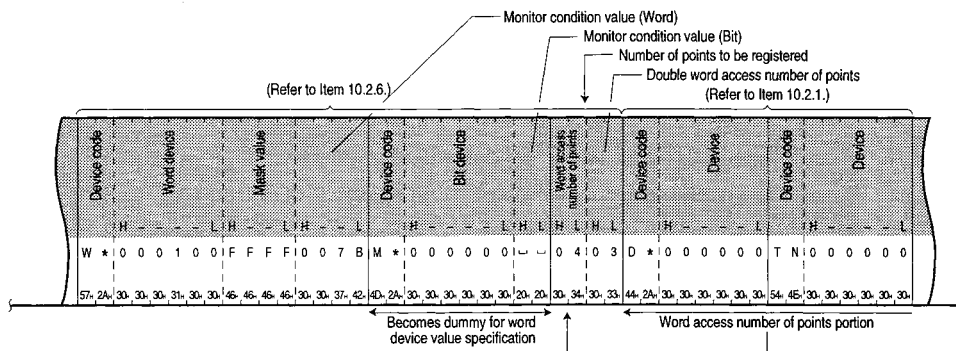
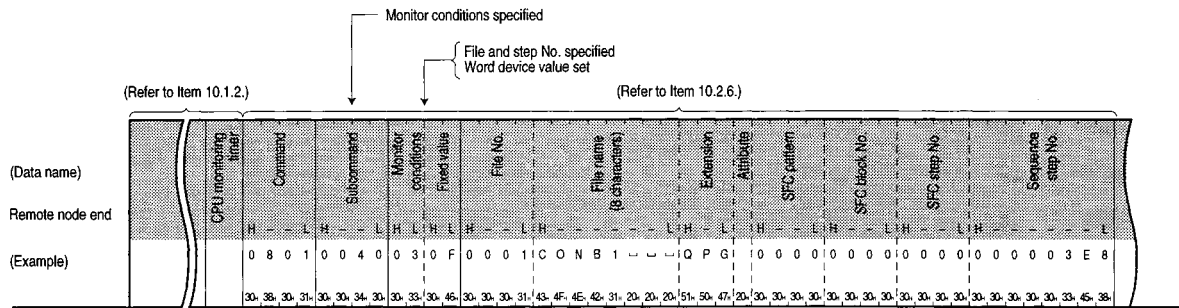

(b) When conducting monitor data registration using the following contents using binary code exchange

① Monitor conditions

The link register W100 value becomes 7BH (123) when the program file CONB1.QPG step No. 1000 is executed.

② Device memory to conduct monitor (Read)

- Word access : D0, T0, M100 to M115, X10 to X1F
- Double word access : D1500 to D1501, Y160 to Y17F, M1111 to M1142

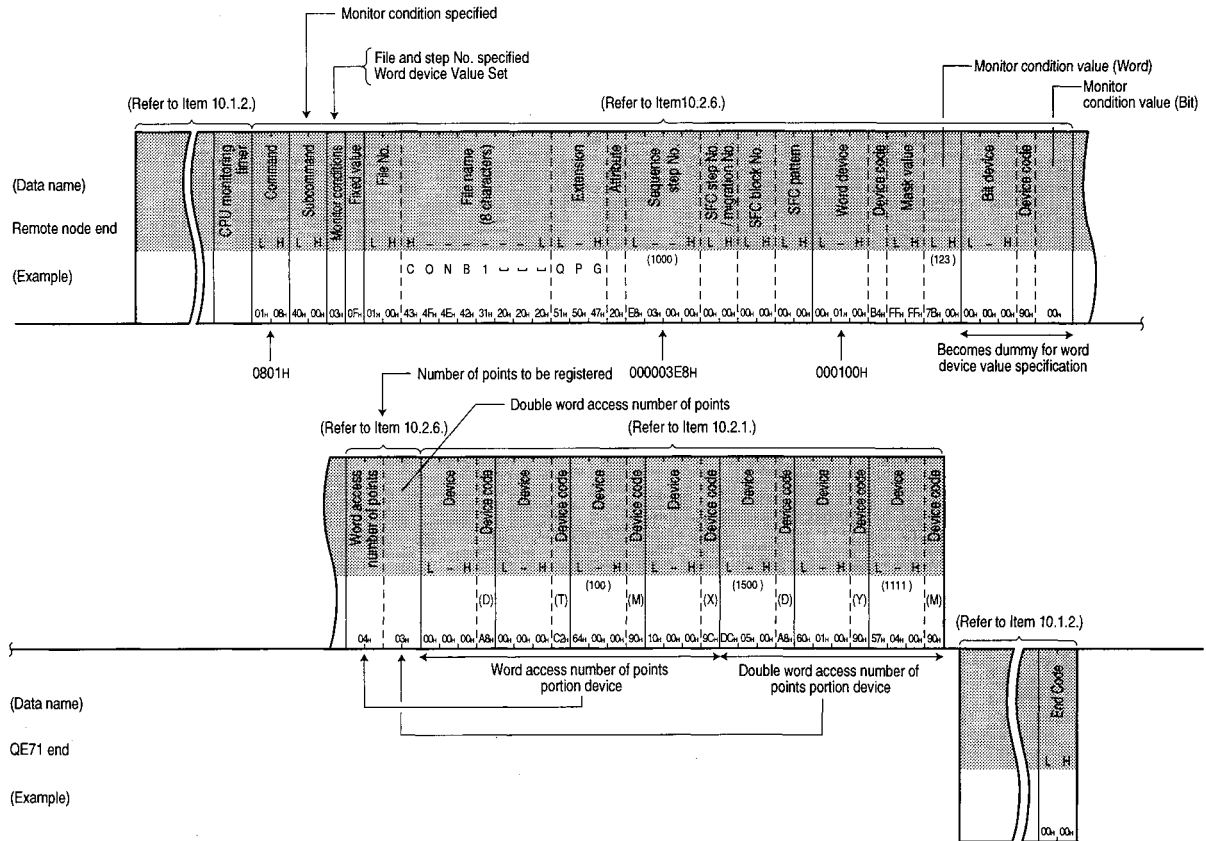

Point

- (1) Set the number of access points in the following range. (The same as when specifying monitor conditions.)
 - For bit devices it will be divided into 16 bits per point for word access and 32 bits per point for double word access.
 - For word devices it will be divided into 1 word per 1 point for word access and 2 words per 1 point for double word access.
- ① When accessing the QnACPU via the QE71's installed station QnACPU and MELSECNET/10
 - Access number of points $1 \leq (\text{word access number of points} + \text{double word access number of points}) \leq 96$
- ② When accessing other than that in ① above
 - Cannot be accessed.
- (2) When accessing a PLC CPU bit device other than those in ① above, the device No. must be set in multiples of 16 (for decimal : 0, 16,...).

4 Registration device memory monitor (Command : 0802)

This section uses an example to explain the monitor control procedure for registering device memory using monitor data registration (command : 0801).

The monitor control procedure is the same regardless of whether monitor condition specifications exist during monitor data registration.

(Control procedure)

(a) When conducting monitoring using ASCII code exchange when conducting monitor data registration for the following device memories

(Device memories for which monitor data is being registered)

- Word access : D0, T0, M100 to M115, X10 to X1F
- Double word access : D1501 to D1501, Y160 to Y17F, M1111 to M1142

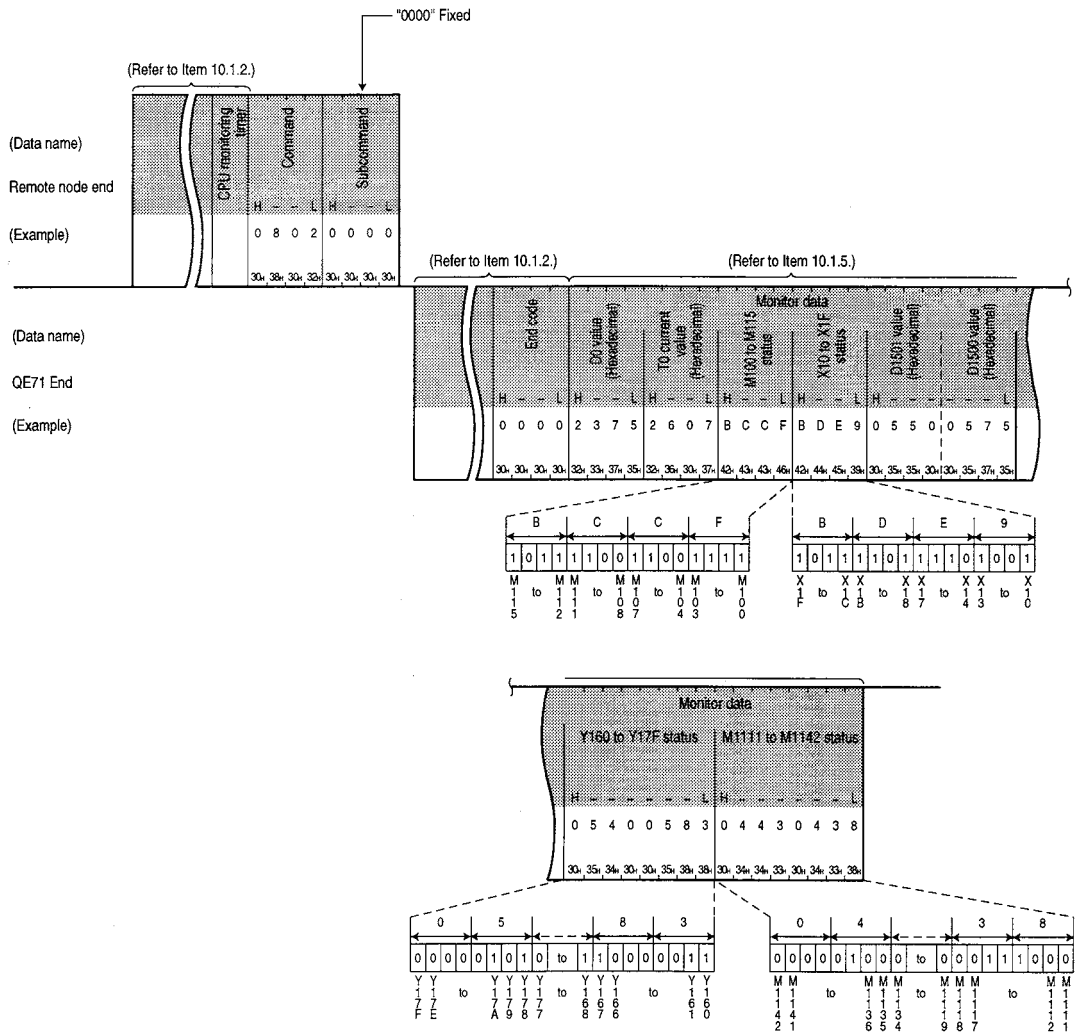

(b) When conducting monitoring using binary code exchange when conducting monitor data registration for the following device memories (Device memories for which monitor data is being registered)

- Word access : D0, T0, M100 to M115, X10 to X1F
- Double word access : D1500 to D1501, Y160 to Y17F, M1111 to M1142

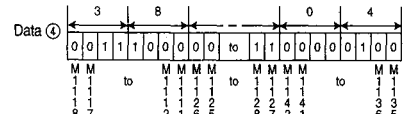
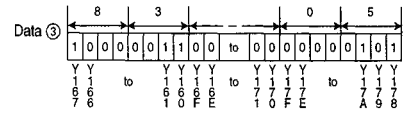
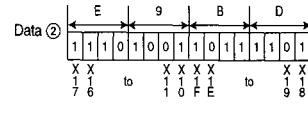
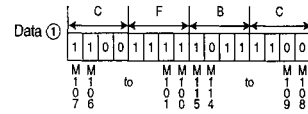
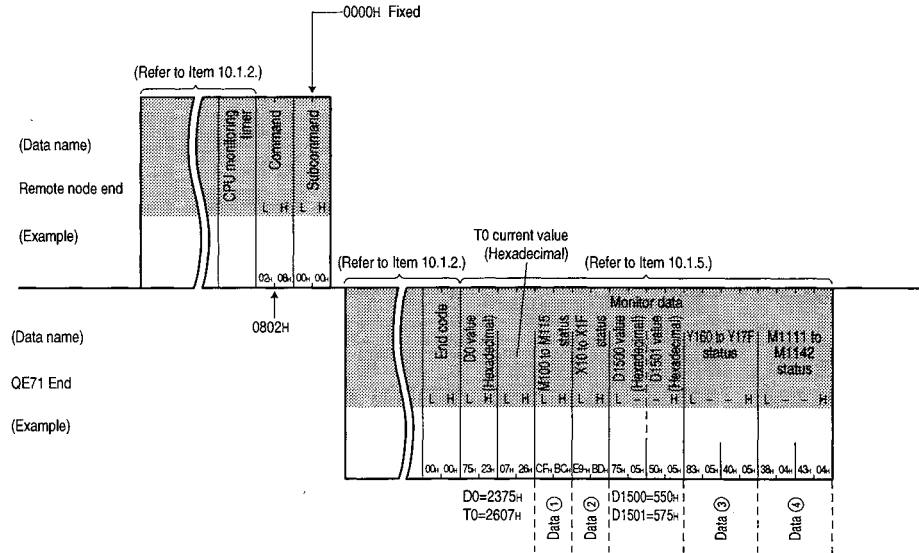

10.2.10 Multiple Block Batch Read, Batch Write

This section uses an example to explain the read/write control procedure for performing by randomly specifying multiple blocks, n-points of the bit device memory (1 point = 16 bits) and word device memory (1 point = 1 word) are set as one block.

Point
 Batch read and batch write for multiple blocks are used for exchanging with the QnACPU.
 This can be executed with a module shown in Item 2.5.3.

1 Data order in the character area during the multiple block batch read

Data order in the character area during the multiple block batch read is described.

- ① Data order in ASCII code

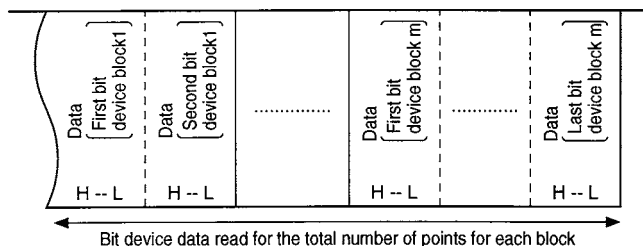
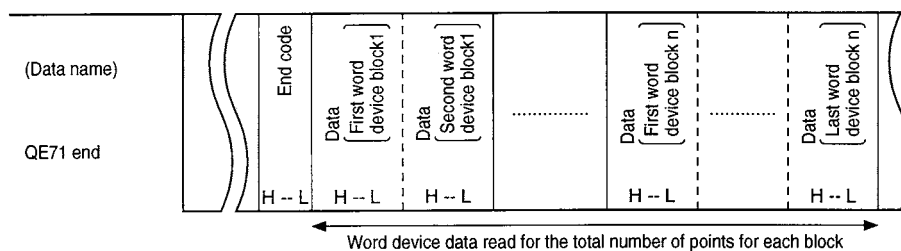
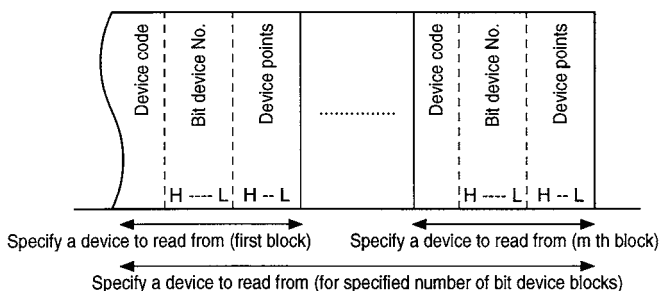
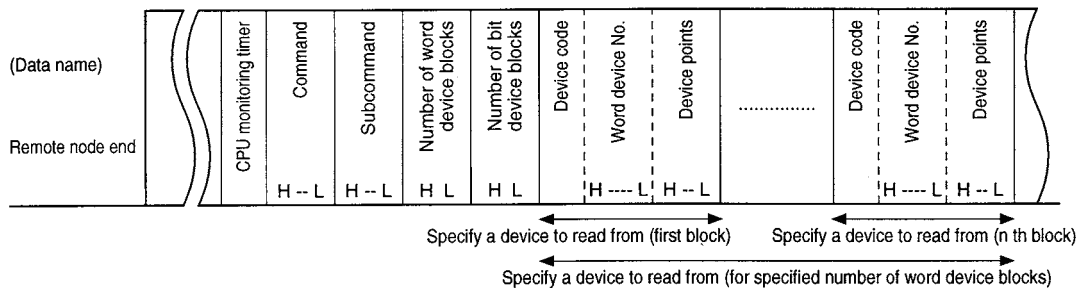

② Data order in binary code

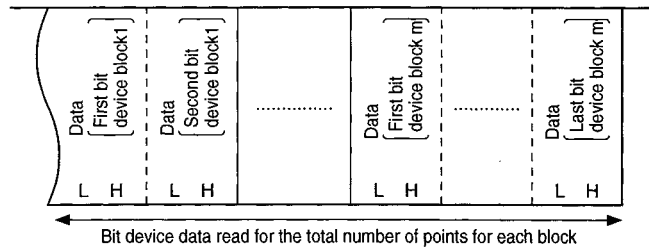
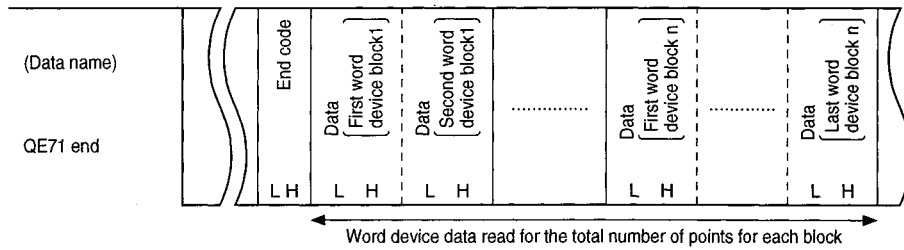
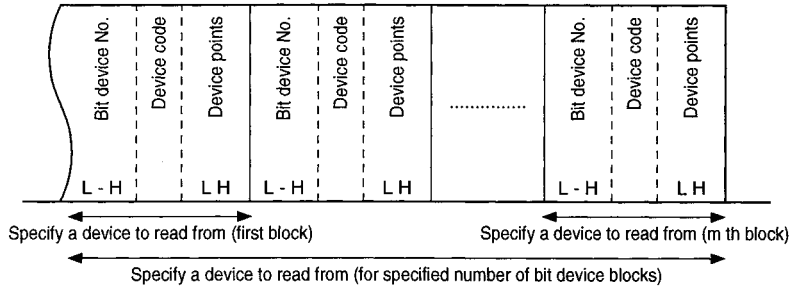
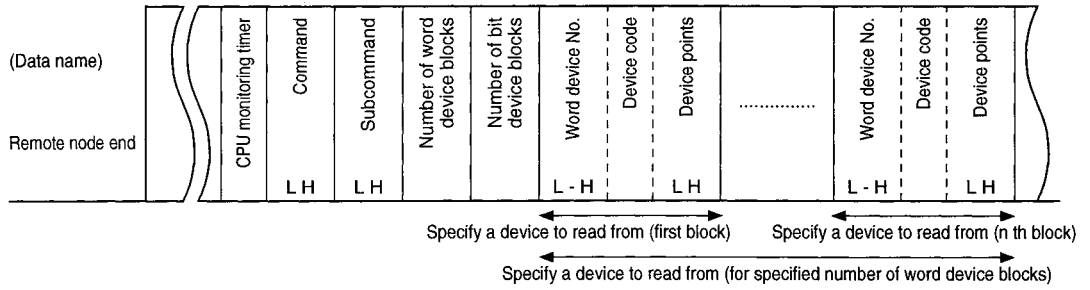

2 Data order in the character area during the multiple block batch write

Data order in the character area during the multiple block batch write is described.

① Data order in ASCII code

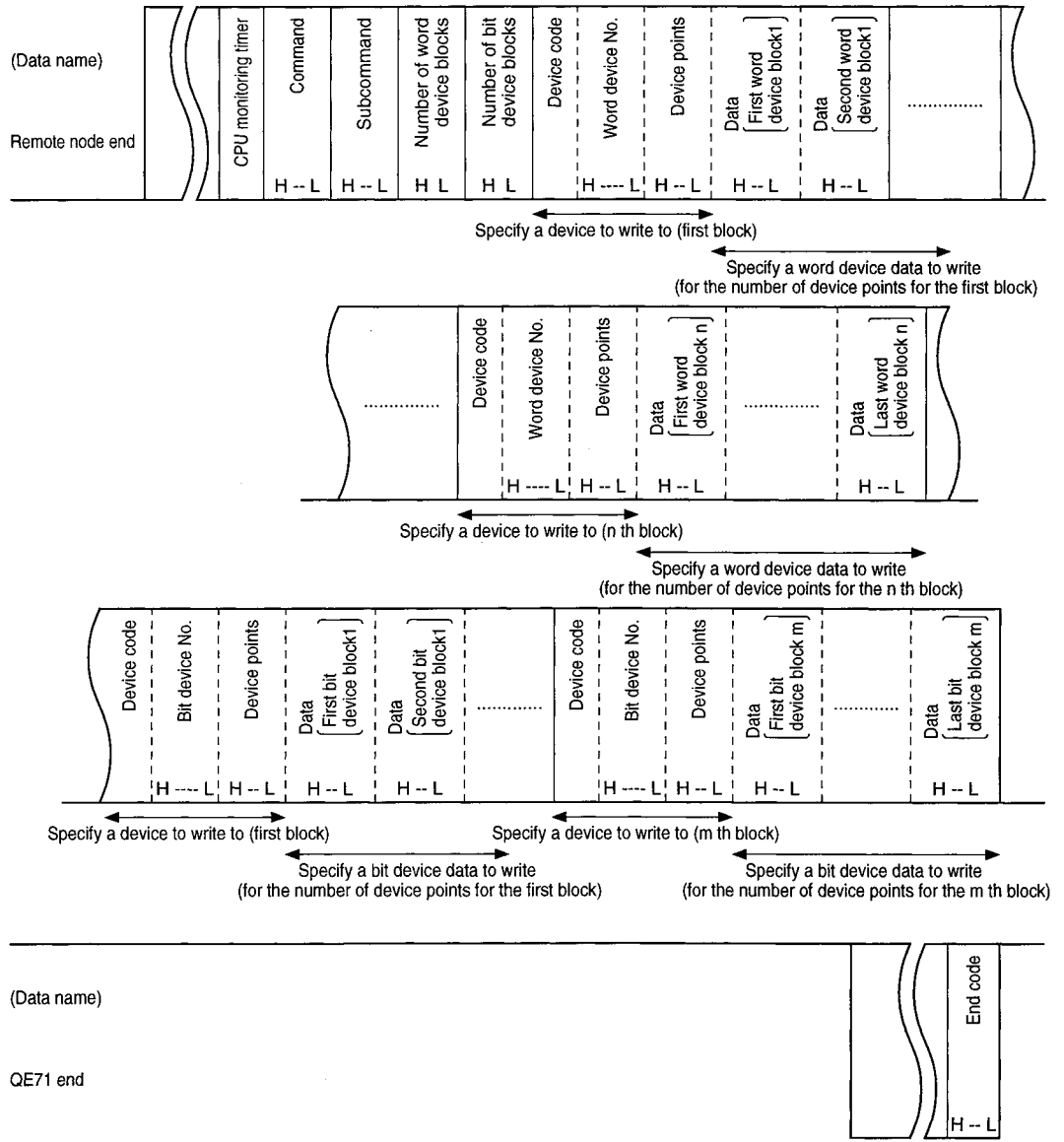

② Data order in binary code

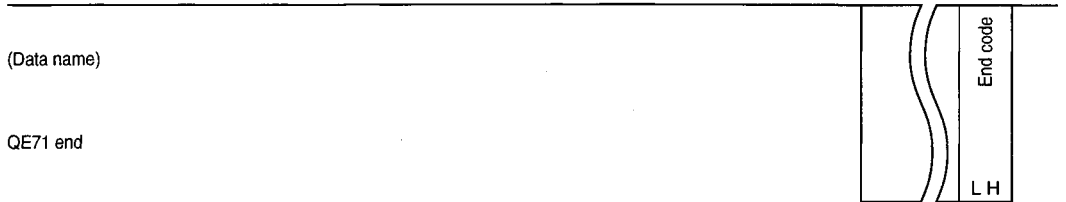
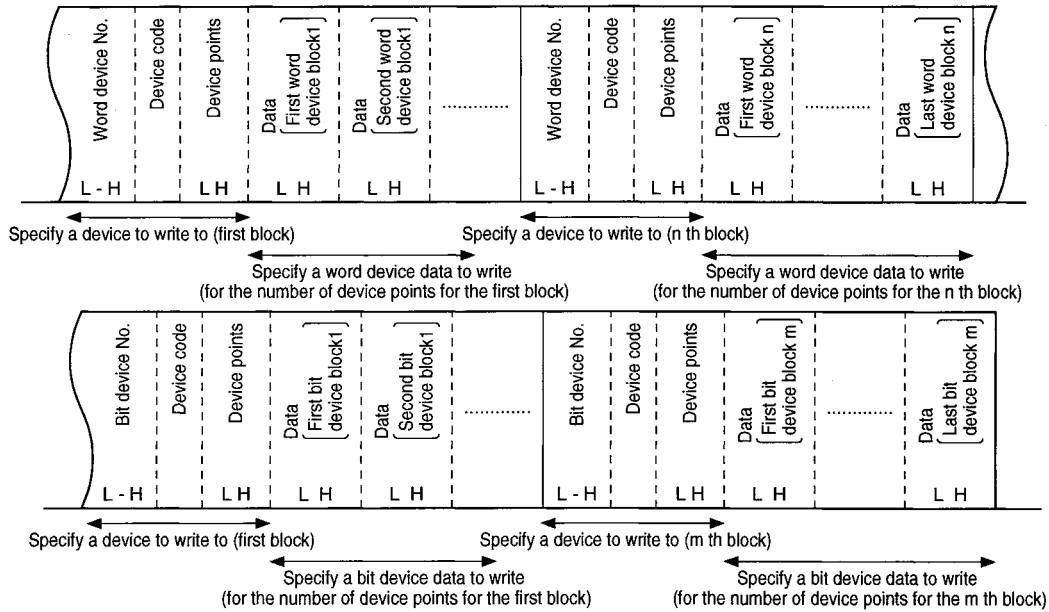
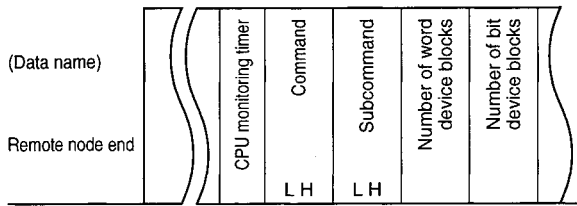

3

Details of the multiple block batch read and batch write

Details of the multiple block batch read and batch write are described.

Besides the data shown below, the details are the same as when using the other commands.

(a) Number of word device blocks and number of bit device blocks

Specifies each of the number of word device blocks or bit device blocks to be sent directly after this data in the batch read or batch write to the word device and bit device.

① During data exchange in ASCII code

Each number of blocks are converted to 2-digit ASCII code (hexadecimal) and transmitted.

(Example) For 5 blocks Becomes "05", and transmitted starting from "0".

For 20 blocks Becomes "14", and transmitted starting from "1".

② Data exchange in binary code

Transmits 1-byte numeric value indicating number of blocks.

(Example) For 5 blocks 05H is transmitted.

For 20 blocks 14H is transmitted.

③ Specify each number of blocks so the following is satisfied:

$120 \geq \text{number of word device blocks} + \text{number of bit device blocks}$

④ When setting one of the number of blocks to 0, the corresponding device number, device code, device points, and data specifications are not necessary.

(b) Word device number and bit device number

Specifies the head word device and bit device for each block to which batch read or batch write is performed, when continuous word/bit devices are used as one block.

① Data exchange in ASCII code

The head device number of each block is converted to 6-digit ASCII code and transmitted.

(Example) For internal relay M1234 and link register W1234:

The internal relay M1234 is converted to "001234" or "└└1234" and the link register W1234 "001234" or "└└1234". The transmission starts from "0" or "└".

② Data exchange in binary code

The head device number of each block is indicated in a 3-byte numeric value and sent.

(Example) For internal relay M1234 and link register W1234:

The internal relay M1234 is converted to 0004D2H and transmitted in the order, D2H, 04H, and 00H.

The link register W1234 is converted to 001234H and sent in the order 34H, 12H, and 00H.

(c) Device code

Identifies the head device memory for each block for batch read and batch write.

The device code for each device is shown in Section 10.2.1 3.

① Data exchange in ASCII code

Each device code is converted to 2-digits ASCII code (hex adecimal) and transmitted.

(Example) For internal relay (M) and link register (W):

The internal relay (M) is converted to "M*" and link register (W) to "W*", and transmitted in the order "M" to "W".

② Data exchange in binary code

1-byte numeric value indicating each device code is transmitted.

(Example) For internal relay (M) and link register (W):

The internal relay (M) is transmitted as 90H, and link register (W) is transmitted as B4H.

(d) Device points

This is used when the continuous word devices or bit devices are used as one block.

It specifies the number of points in the continuous device range of each block for batch read or batch write (1 point=16 bits for bit device memory and 1 point=1 word for word device memory).

① Data exchange in ASCII code

The number of points for each block is converted to a 4-digit ASCII code (hex adecimal) and sent.

(Example) For 5 points..... Converted to "0005" and transmitted starting from "0".

For 20 points..... Converted to "0014" and transmitted starting from "0".

② Data exchange in binary code

A 2-byte value indicating the number of points for each block is transmitted.

(Example) For 5 points..... Converted to 0005H and transmitted starting from 05H.

For 20 points..... Converted to 0014H and transmitted starting from 14H.

③ Each device points must be specified in the following range:

- For multiple block batch read

$480 \geq \text{total number of points for all word device blocks} + \text{total number of points for all bit device blocks}$

- For multiple block batch write

$480 \geq 4 \times (\text{number of word device blocks} + \text{number of bit device blocks}) + \text{total number of points for all word device blocks} + \text{total number of points for all bit device blocks}$

4 Multiple block batch read (Command: 0406)

This section uses an example to explain the control procedure for reading by specifying multiple blocks randomly, when n-points of continuous bit device memory (1 point = 16 bits) and word device memory is considered as one block.

(a) When the following device memory is read in ASCII code exchange:

- Word device memory : 2 blocks; D0 to D3 (4 points), W100 to W107 (8 points)
- Bit device memory : 3 blocks; M0 to M31 (2 points), M128 to M159 (2 points), B100 to B12F (3 points)

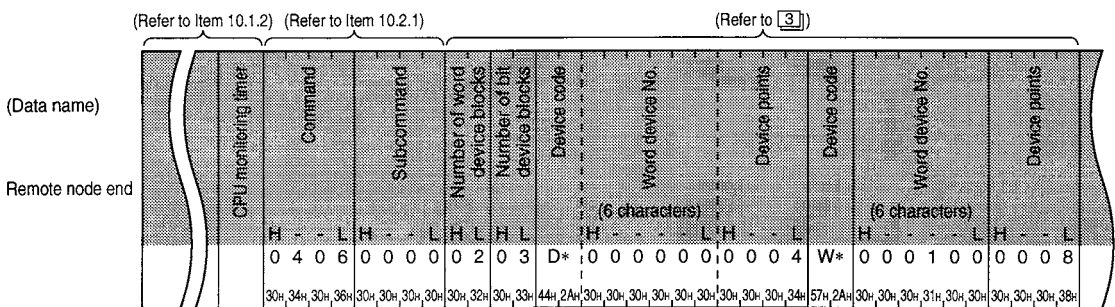

Specify the first device of each block for the number of word device blocks

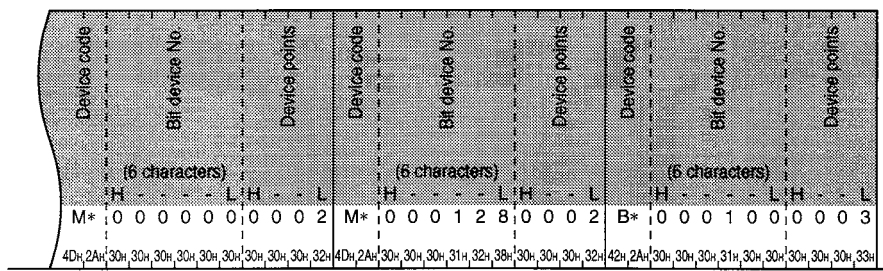

Specify the first device of each block for the number of bit device blocks

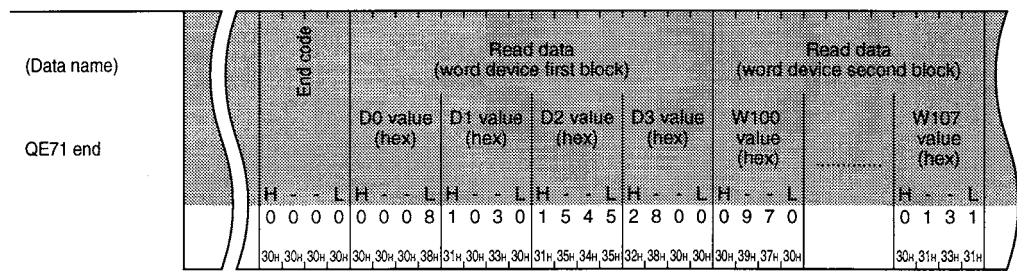

(Refer to Item 10.1.2)

(Refer to Item 10.1.3)

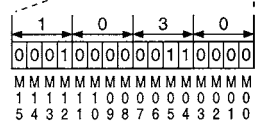
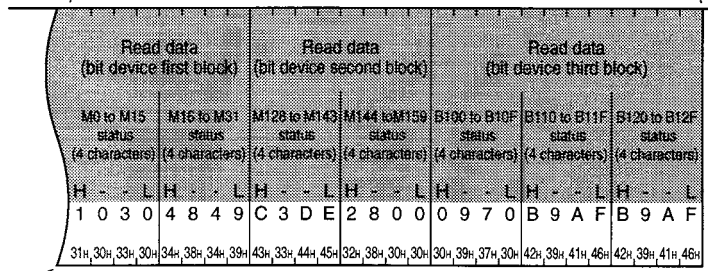

5 Multiple block batch write (Command:1406)

This section uses an example to explain the control procedure for writing by specifying multiple blocks randomly, when n-points of continuous bit device memory (1 point = 16 bits) and word device memory is considered as one block.

(a) When writing to the following device memory in ASCII code exchange:

- Word device memory : 2 blocks; D0 to D3 (4 points), W100 to W107 (8 points)
- Bit device memory : 3 blocks; M0 to M31 (2 points), M128 to M159 (2 points), B100 to B12F (3 points)

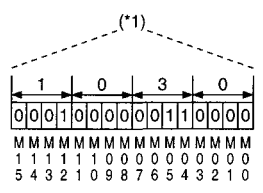
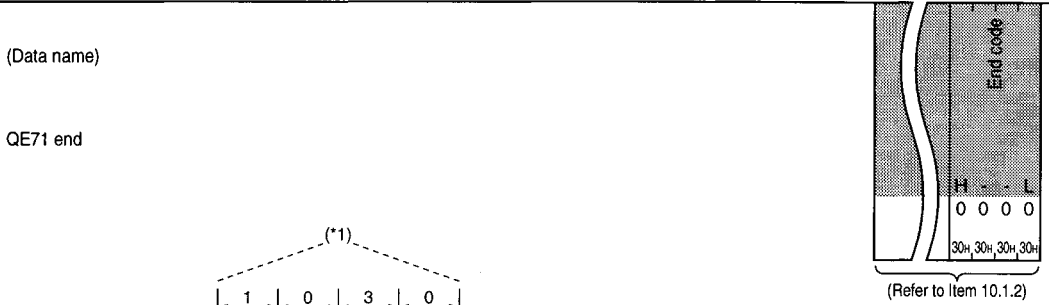
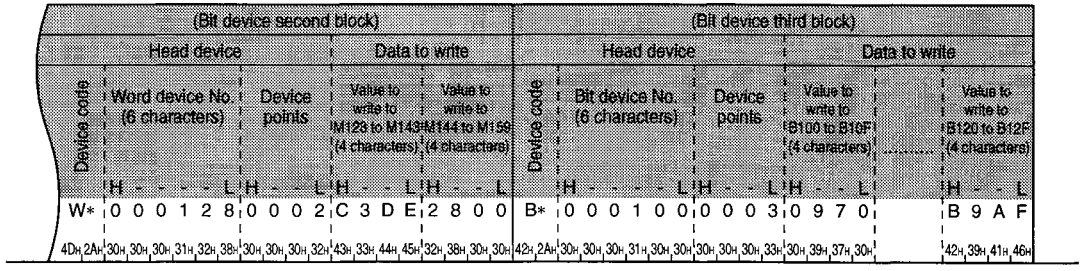
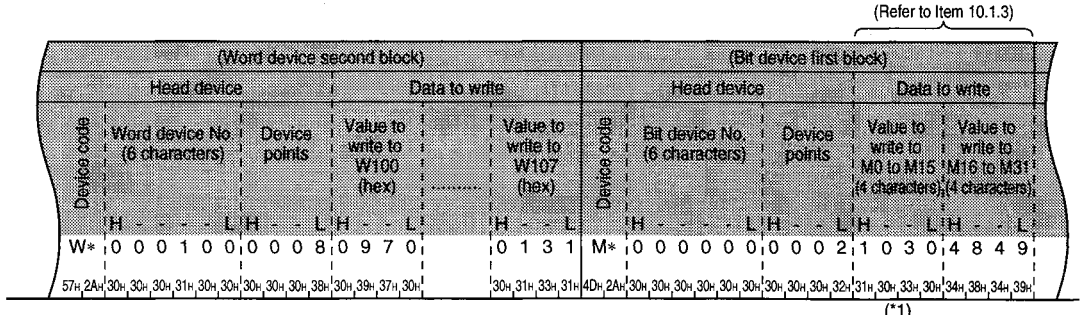
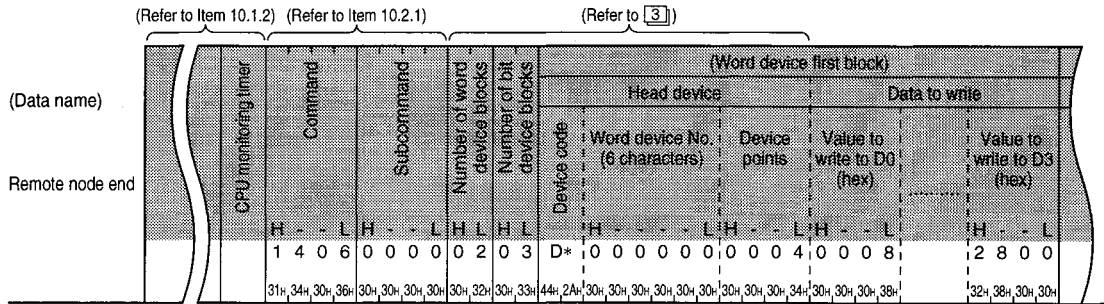

(b) When writing to the following device memory in binary code exchange:

- Word device memory : 2 blocks; D0 to D3 (4 points), W100 to W107 (8 points)
- Bit device memory : 3 blocks; M0 to M31 (2 points), M128 to M159 (2 points), B100 to B12F (3 points)

(Refer to Item 10.1.2) (Refer to Item 10.2.1) (Refer to ③)

(Data name)	Remote node end	CPU monitoring timer		Command		Subcommand		Number of word device blocks	Number of bit device blocks	(Word device first block)						
		Head device		Data to write		Head device				Data to write						
		Word device No.	Device code	Device points	Value to write to D0 (hex)	Value to write to D3 (hex)	Word device No.			Device code	Device points	Value to write to D0 (hex)	Value to write to D3 (hex)			
		L	H	L	H					L	H	L	H	L	H	
		1406H	06H	0000H	14H	00H	00H	02H	03H	000000H	A8H	0004H	0008H	2800H	00H	28H

(Refer to Item 10.1.3)

(Word device second block)					(Bit device first block)						
Head device		Data to write			Head device		Data to write				
Word device No.	Device code	Device points	Value to write to W100 (hex)	Value to write to W107 (hex)	Bit device No.	Device code	Device points	Value to write to M0 to M15	Value to write to M16 to M31		
L	H	L	H	L	H	L	H	L	H	L	H
000100H	(W)	0008H	0970H	0131H	000000H	(M)	0002H	1030H	4849H		
00H	01H	00H	08H	00H	70H	09H	31H	01H	00H	00H	00H

(*1)

(Bit device second block)					(Bit device third block)						
Head device		Data to write			Head device		Data to write				
Word device No.	Device code	Device points	Value to write to M128 to M143	Value to write to M144 to M159	Bit device No.	Device code	Device points	Value to write to B100 to B10F	Value to write to B120 to B12F		
L	H	L	H	L	H	L	H	L	H	L	H
000080H	(M)	0002H	C3DEH	2800H	000100H	(B)	0003H	0970H	B9AFH		
80H	00H	00H	90H	02H	00H	DEH	C3H	00H	28H		

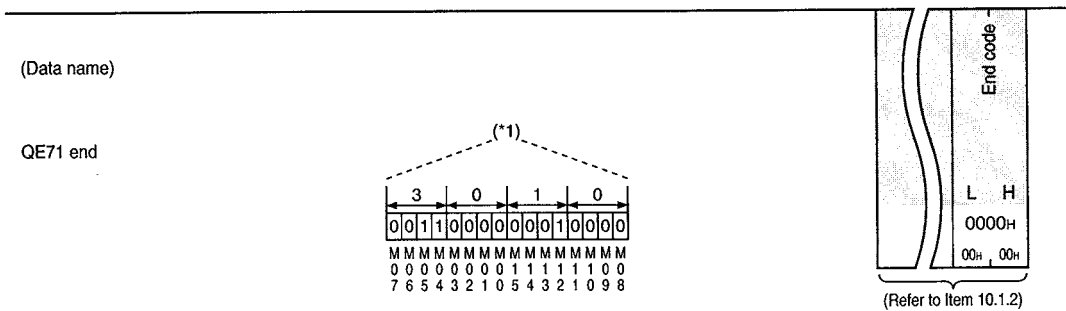

Point

(1) Specify each device points so that the following is satisfied:
 $480 \geq 4 \times (\text{number of word device blocks} + \text{number of bit device blocks}) + \text{total number of points for all word device blocks} + \text{total number of points for all bit device blocks}$

(2) This command can be executed only for QnACPU's shown in Item 2.5.3.

10.2.11 Reading and Writing Using Device Memory Extension Specification

The device memory extension specification is used for remote nodes to specify devices other than those given in Item 10.2.1 [3] and to specify additions such as the device No. of the device memory to be accessed and the network No.

Following is a summary of the device memory extension specifications.

From this item on the explanation for these specification expressions will be shown as [Specification-1] to [Specification-5].

[Specification-1]

This specification is used to access the MELSECNET/10's link direct device. (Link input, link output, link special relay, etc. Refer to [2] table.)

[Specification-2]

This specification is used to access the QnACPU station and MELSECNET/10 remote station special function module's special direct device. (Buffer register, refer to [2] table.)

[Specification-3]

Specifies the subject module using I/O signal extension setting additions for the network No. from ① and ② below.

- ① Specifies the subject module for [Specification-1] above.
(Voluntary network No.) + (network No. specified by the index register) network module
- ② Specifies the subject module for [Specification-2] above.
(Voluntary I/O signal No.) + (I/O signal No. specified by the index register) special functions module

For example, when multiple network modules are installed in the access station, the extension setting data and index register "Z0" specified by the remote node that are explained in the following diagram, make it possible to access the same device memory (SW5) for each module.

[Specification-4]

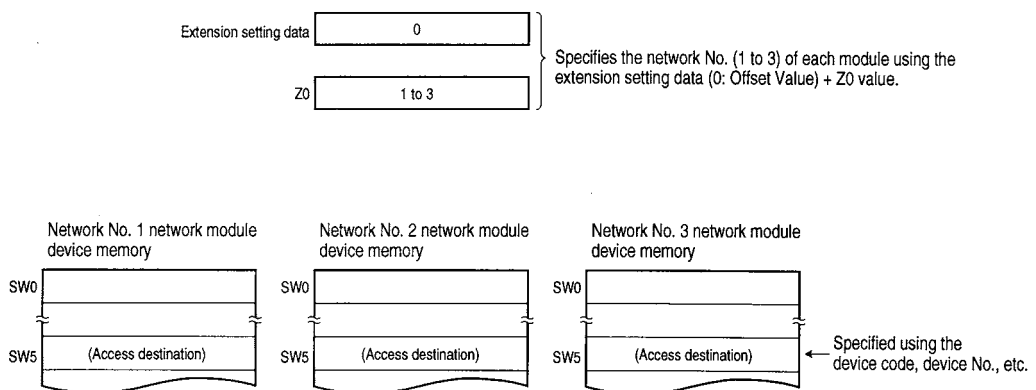

Specifies the subject device No. for the devices in [Specification-1], [Specification-2], and Item 10.2.1 [3] above to which device additions have been made in the device No. and index register. For example, access to device memory (D4) is possible by specifying D0 and Z0.

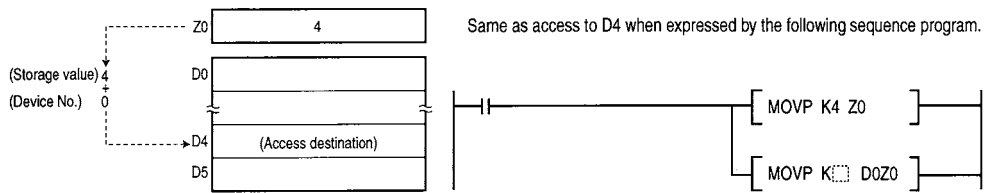

In addition, device memory (M16 or M16 to M31, etc.) can be done by specifying M0 and Z0.

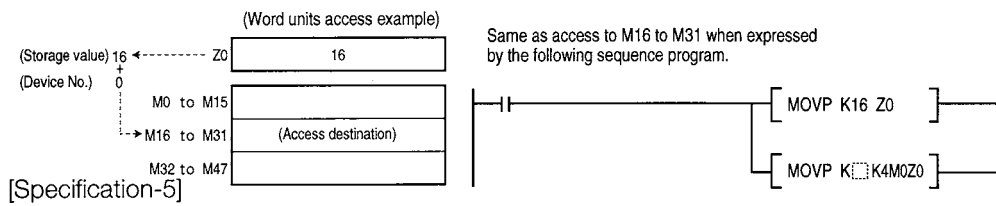

Indirectly specifies the word device that will become the access destination device memory address for the specified word device storage value.

In the following case, the device memory is allocated to the device memory address 00002764H memory.

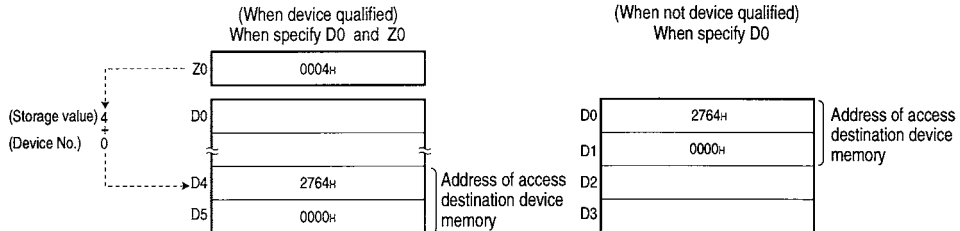

Point

When access is conducted by the remote node's indirect specification of the device memory, before access arrange the following items with the PLC CPU.

- ① The device memory to be accessed checks the address of the allocated memory using the PLC CPU ADRSET command.
- ② The address checked in ① above, is stored in the device memory to be specified by the indirect specification.

(Example) Example sequence program that stores the D100 address in D0, D1 when the remote node accesses D100.
(D100 can be accessed by the remote node indirectly specifying D0.)

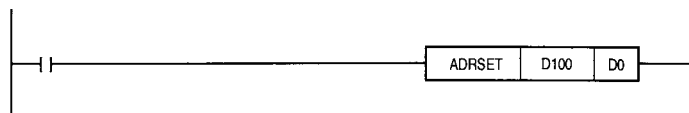

1 Character area data order and contents when specifying device memory extension

This section explains the specification contents of the extension specification addition portion when the device memory that conducts data read and write is specified with an extension.

Refer to Item 10.2.1 **2** **3** regarding the same data items as when extension is not specified for device memory.

Point

(1) When specifying an extension change the device memory specification portion when not set for extension to being specified for extension.

(2) When specifying multiple device memories, specify them all for extension.

(a) Device memory specification portion data order when specifying extension for device Memory

① Data order when using ASCII code

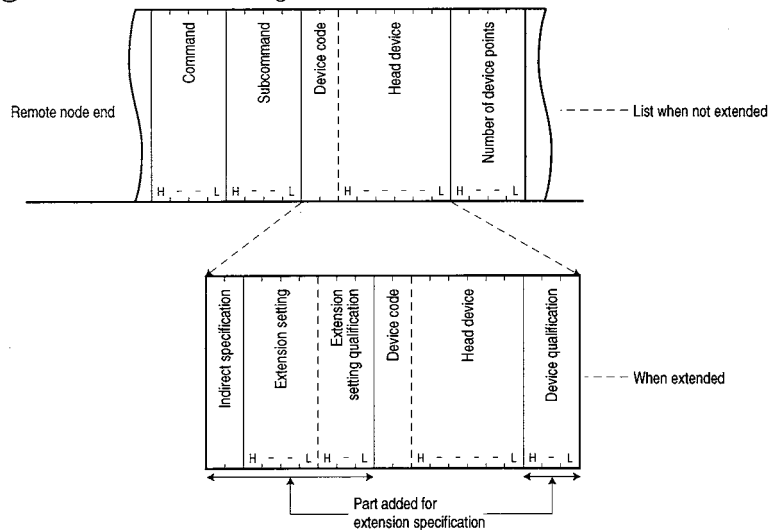

② Data order when using binary code

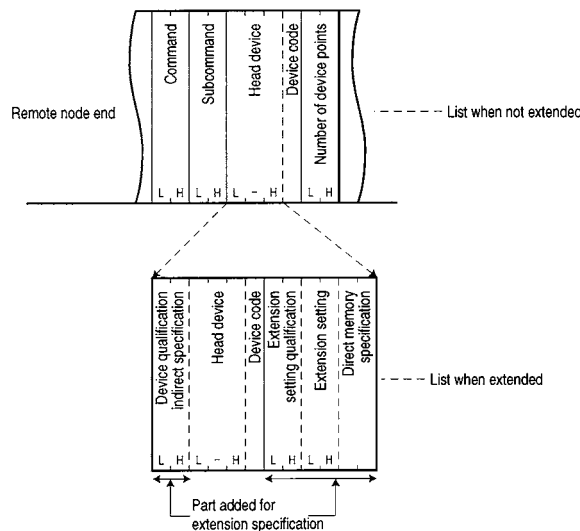

(b) Character portion contents when extension specifying device memory

Shows the specification values for the character portion when extension specifying device memory.

(For ASCII code)

		Remote node specification values					Number of specified characters
		(Specification-1)	(Specification-2)	(Specification-3)	(Specification-4)	(Specification-5)	
Sub command	Without monitor conditions	"0080" / "0081" (Refer to ①)					4
	With monitor conditions	"00C0" / "00C1" (Refer to ①)					
Indirect specification		"00"			"0@"	2	
Extension setting		"J□" (Refer to ②)	"U□" (Refer to ②)	Either of those at left / "0000" (Refer to ②)		"0000"	4
Extension setting qualification		"000"		"Z□" (Refer to ③)	Either of those at left (Refer to ③)	"000"	3
Device code		Refer to items ② (a) and 10.2.1 ③					2
Head device and device							6
Device qualification		"000"			"Z□" (Refer to ④)	Either of those at left (Refer to ④)	3

(For binary code)

		Remote node specification values					Number of specified bytes
		(Specification-1)	(Specification-2)	(Specification-3)	(Specification-4)	(Specification-5)	
Sub command	Without monitor conditions	0080H / 0081H (Refer to ①)					2
	With monitor conditions	00C0H / 00C1H (Refer to ①)					
Device qualification indirect specification		0000H		40□□H (Refer to ④)	0800H / 08□□H (Refer to ④)	2	
Head device and device		Refer to Items ② (a) and 10.2.1 ③					3
Device code							1
Extension setting qualification		0000H		40□□H (Refer to ③)	Either of those at left (Refer to ③)	0000H	2
Extension setting		□□H (Refer to ②)			0000H		2
Direct memory specification		F9H	F8H	Either of those at left / "00H" (Refer to ②)		00H	1

① Subcommand

This data is used to specify the read/write unit, the type of device to be specified, data read conditions, etc.

(a) Data exchange using ASCII code

As shown below, the numerical values are converted to ASCII code 4 digits (hexadecimal) and transmitted from the first digit.

(b) Data exchange using binary code

As shown below, the 2 byte numerical values are transmitted.

(c) The subcommand specification contents are shown below.

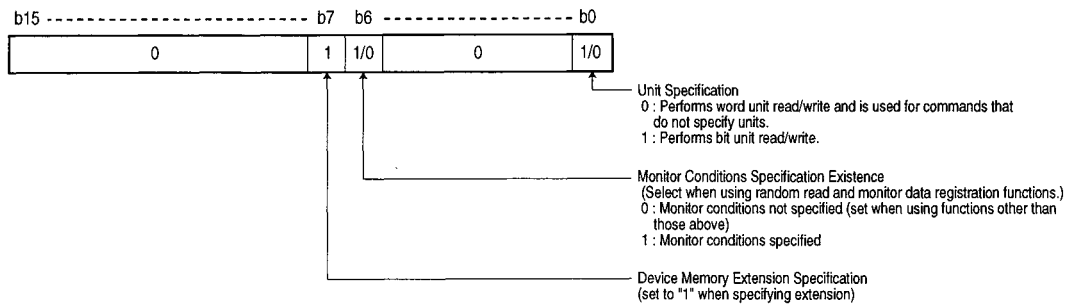

(d) Device memory read timing, etc. for monitor condition specification existence (for random read and monitor data registration) and monitor conditions with specification are explained in Item 10.2.6.

(e) When specifying device memory extension, the monitor condition specification and unit specification change the subcommand to 0080H, 0081H, 00C0H, 00C1H.

② Extension specification and direct memory specification

This data is used to specify device memory when peripheral equipment is accessing the following device memory.

- Link direct device (Specification-1)
- Special function module direct device (Specification-2)

(a) Data exchange using ASCII code

Specifies only the extension setting data when transmission is conducted for the next value from the first digit.

Specified value	Subject device memory	Remarks
"0000"	(Extension not set)	
"J □"	Link direct device	The subject network No. of the address in the □ portion, is converted to ASCII code 3 digits (hexadecimal) and specified.
"U □"	Special functions module direct device	The subject special function module's head I/O signal for the access to the □ portion, is converted to ASCII code 4 digits (hexadecimal) and the first 3 digits are specified.

(b) Data exchange using binary code

Specifies the extension setting and the direct memory specified data and transmit the next value.

(The extension setting data is transmitted from Low byte (L : bits 0 to 7))

Specified value		Subject device memory	Remarks
Extension setting	Direct memory specification		
0000H	00H	(Extension not set)	
□ H	F9H	Link direct device	Specifies the subject network No. for the access to the □ portion (hexadecimal).
□ H	F8H	Special function module special direct device	Expresses the subject special function module's head I/O signal (hexadecimal) for the access to the □ portion as 4 digits and the first 3 digits are specified.

③ Extension setting qualification (for [Specification-3])

This data is used to specify the network No. for the specified value in the extension settings/the I/O signal offset value and for specifying the voluntary network No. and I/O signal module using the index register.

(a) The following values are transmitted from the first digit when data is exchanged using ASCII code.

Specified value	Description	Remarks
"000"	(No extension setting qualification)	_____
"Z <input type="checkbox"/> "	Index register for extension setting qualification	The No. of the index register used in the <input type="checkbox"/> portion is converted to ASCII code 2 digits (decimal) and set.

(b) Data exchange using binary code

The following numerical values are transmitted from the Low byte (L : bits 0 to 7).

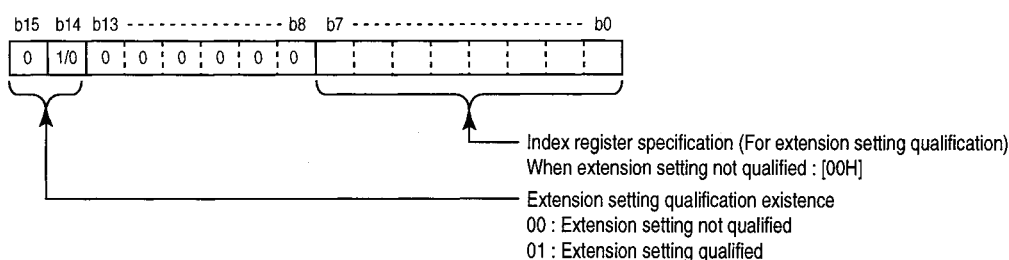

(c) The index register (Z0 to Z15) can be used for extension setting qualification.

(d) Specify the following subtraction value when storing the I/O signal in the index register for extension setting qualification.

$$\begin{array}{l}
 \text{(The value of the first 3 digits when} \\
 \text{the address of the subject module's} \\
 \text{head I/O signal is expressed in 4 digits)}
 \end{array}
 - \text{(Extension setting} \\
 \text{specified value)}
 = \text{(Values stored in the index} \\
 \text{register for extension} \\
 \text{setting qualification)}$$

④ Device qualification and indirect setting

(Device qualification for [Specification-4])

This data is used for the device No.'s offset value that is the specified value in the head device (or device), and for setting the same device's voluntary device No. using the index register.

(Indirect setting for [Specification-5])

This is the data that becomes the device memory address to be accessed from the remote node for the value that is stored in the device memory that is set in the head device (or device) and the following device memory.

Indirect specification is possible when accessing the word device.

(a) Data exchange using ASCII code

Specify only the device qualification data and transmit the following value from the first digit.

Specified value	Description	Remarks
"000"	(No device qualification)	_____
"Z <input type="checkbox"/> "	Index register for device qualification	The No. of the index register used in the <input type="checkbox"/> portion, is converted to ASCII code 2 digits (decimal) and set.

(b) Data exchange using binary code

Specifies the device qualification and indirect specification data and transmits the next value from the Low byte (L : bytes 0 to 7).

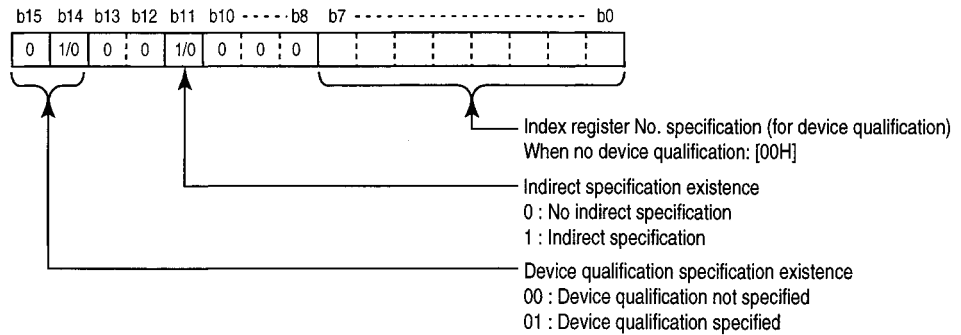

(c) The index register (Z0 to Z15) can be used for extension setting qualification.

2 Device memory for which extension specification is possible and example specification

(a) Device memories for which extension specification is possible

The following device memories can be used as the QnACPU station's extension specification via the QE71 installed station and MELSECNET/10.

- ① QnACPU device memory (Refer to Item 10.2.1 **3**)
- ② Network module link direct device and special functions module special direct device

Classification	Device	Device type		Extension setting		Device code		Device No. range	Expression		Remarks
		Bit	Word	For ASCII Code	For binary Code	For ASCII Code	For binary Code		Decimal	Hexadecimal	
Link direct device	Link input	○		J □	F9H	X*	9CH	000000 to 001FFF		○	Specify the network No. in the extension settings □.
	Link output	○				Y*	9DH			○	
	Link relay	○				B*	A0H			○	
	Link special relay	○				SB	A1H			○	
	Link register		○			W*	B4H			○	
	Link special register		○			S*	B5H			○	
Special direct device	Buffer register (Buffer memory)		○	U □	F8H	G *	ABH	000000 to 016383	○		Specify the subject module's I/O signal in the extension settings □.

1 The device code specification's "" and the head device (or device) specification's "00...0," can be specified as blank (code : 20H) as shown in Item 10.2.1 **2** (c) **2** **3**.

(b) Example device memory extension specification

Following is shown an example specification for when a device memory is given an extension specification (when the subcommand is monitor conditions not specified).

For [Specification-1]

(a) When accessing the following device memories

- Subject module: the network No. is the 8 (008H) network module.
- Device No. : X100 access with bit unit
(Specification method when using ASCII code)

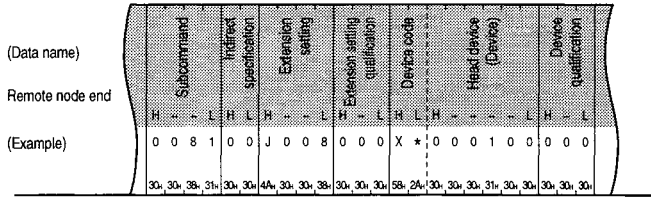

(Specification method when using binary code)

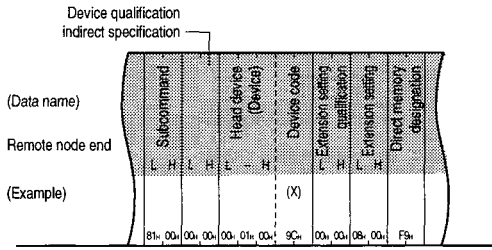

(b) When accessing the following device memories

- Subject module: the network No. is the 8 (008H) network module.
- Device No. : W100 access with word unit
(Specification method when using ASCII code)

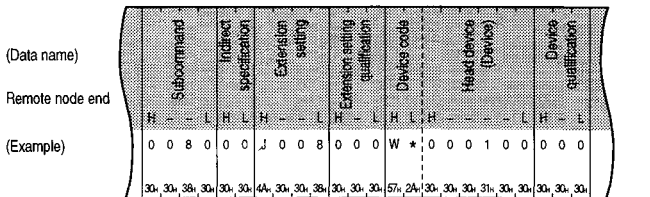

(Specification method when using binary code)

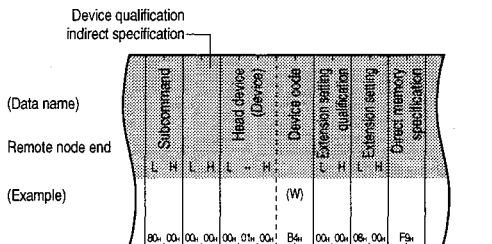

For [Specification-2]

(a) When accessing the following buffer memories

- Subject special functions module : the head I/O signal is 010H special function module
- Head device : 3072 (C00H)

(Specification method when using ASCII code)

(Data name)	Subcommand				Indirect specification				Extension setting				Extension setting qualification				Device code				Head device (Device)				Device qualification			
Remote node end	H	-	L		H	L	H	L	H	L	H	L	H	L	H	L	H	-	-	-	L	H	-	-	-	L		
(Example)	0	0	8	0	0	0	0	0	U	0	0	1	0	0	0	0	G	*	0	0	3	0	7	2	0	0	0	0
	30 _r	30 _r	38 _r	30 _r	30 _r	30 _r	55 _r	30 _r	30 _r	30 _r	30 _r	31 _r	30 _r	30 _r	30 _r	30 _r	47 _r	2A _r	30 _r	30 _r	33 _r	30 _r	37 _r	32 _r	30 _r	30 _r	30 _r	30 _r

(Specification method when using binary code)

(Data name)	Subcommand				Head device (Device)				Device code				Extension setting				Extension setting qualification				Direct memory specification			
Remote node end	L	H	L	H	L	-	H		L	H	L	H	L	H	L	H	L	H	L	H	L	H	L	H
(Example)	80 _r	00 _r	00 _r	00 _r	00 _r	0C _r	00 _r	AP _r	00 _r	00 _r	01 _r	00 _r	F8 _r											

Device qualification indirect specification

For [Specification-3]

(a) When accessing the following device memories

- Subject module: the network No. is 12 (0CH) + Z0 network module
- Head device : W100

(Specification method when using ASCII code)

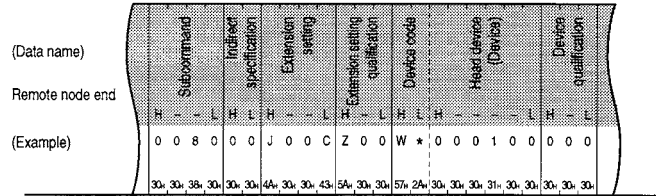

(Specification method when using binary code)

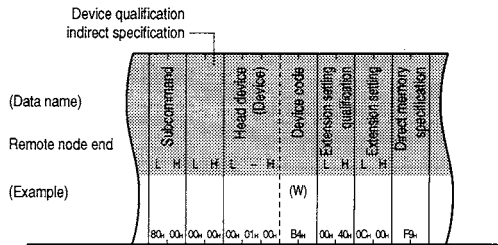

(b) When accessing the following buffer memories

- Subject special functions module: the head I/O signal is 010H + Z1 special function module
- Head address : 3072 (C00H)

(Specification method when using ASCII code)

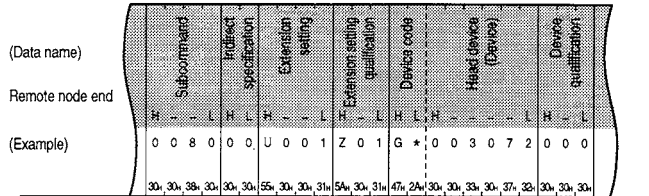

(Specification method when using binary code)

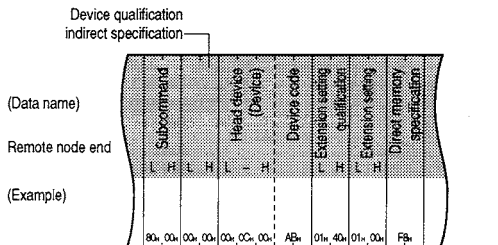

For [Specification-4]

(a) When accessing the following device memories

- Device No. : the internal relay (M) is specified by M200 + Z3...access using bit unit
(Specification method using ASCII code)

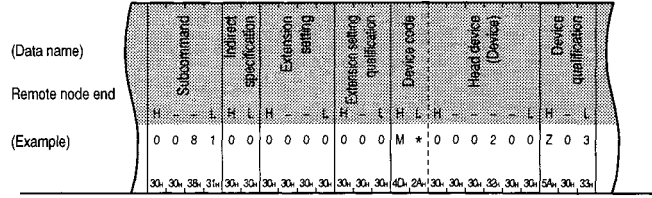

(Specification method when using binary code)

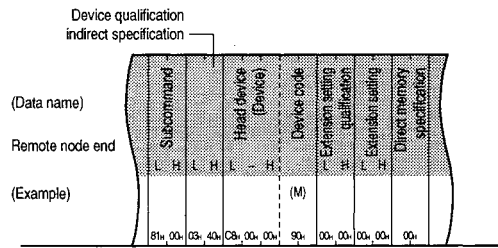

(b) When accessing the following device memories

- Device No. : data register (D) is specified by D100 + Z4...access using word unit
(Specification method using ASCII code)

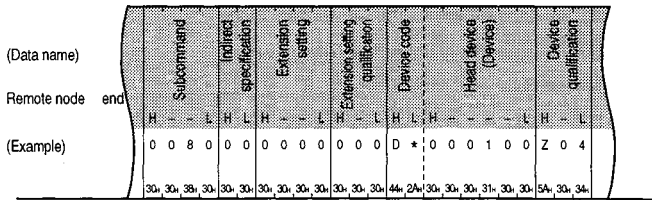

(Specification method when using binary code)

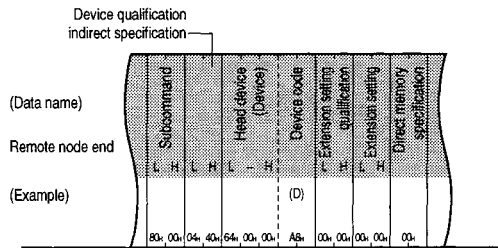

(c) When accessing the following buffer memories

- Subject module : network No. is 8 (008H) network module
- Device No. : the link input (X) shown by X100 + Z5...access using bit unit
(Specification method using ASCII code)

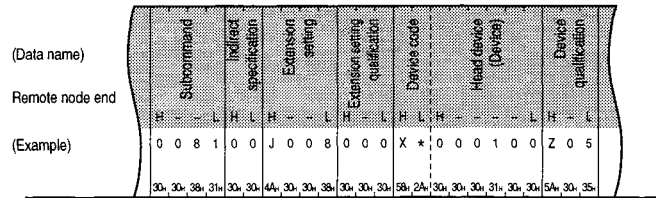

(Specification method using binary code)

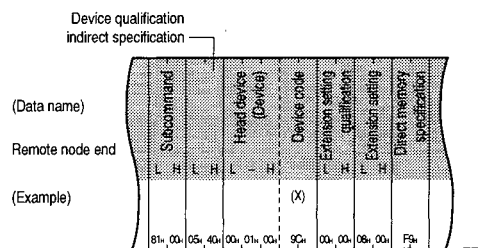

(d) When accessing the following buffer memories

- Subject module : the network module shown as the 8 (008H) + Z11 by the network No.
- Device No. : the link register (W) shown by W10 + Z6...access using word unit
(Specification method using ASCII code)

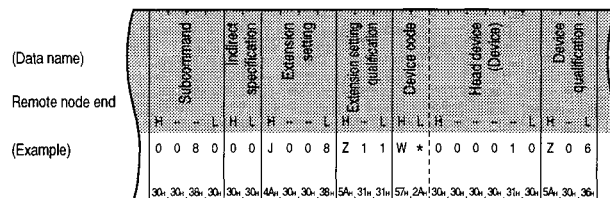

(Specification method using binary code)

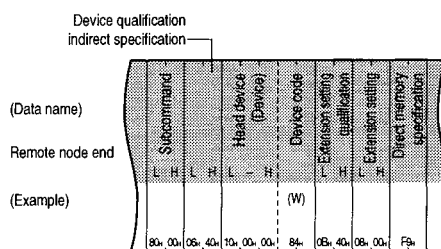

(e) Access the following buffer memories

- Subject special function module : the head I/O signal is 010H special function module
- Head address : the address shown by 3072 (C00H) + Z7
(Specification method using ASCII code)

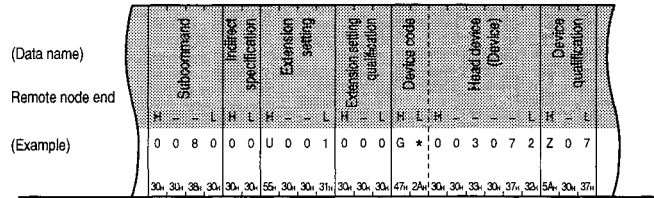

(Specification method using binary code)

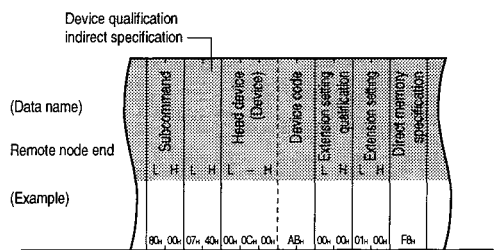

(f) When accessing the following buffer memories

- Subject special function module : the head I/O signal is 010H + Z12 special function module
- Head address : the address shown by 3072 (C00H) + Z7
(Specification method using ASCII code)

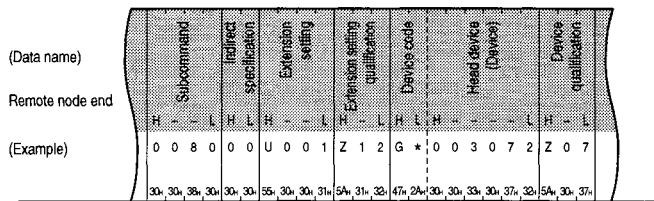

(Specification method using binary code)

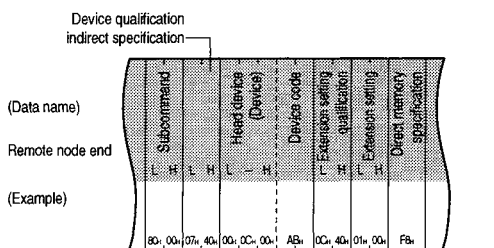

For [Specification-5]

When accessing the following device memories

- Device No. : the address device memory stored in data register (D) shown by D100 + Z4.....access using word unit

(Specification method using ASCII code)

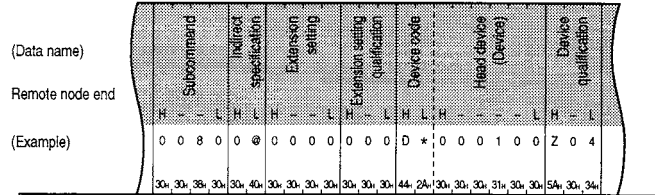

(Specification method using binary code)

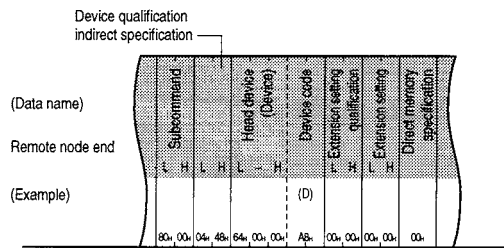

3 Restrictions when specifying device memory extension

Following is shown the restrictions when specifying extensions for device memories.

(a) Commands for which device memory extension specification is possible

A description for whether device memory extension specification is possible is shown for each device memory read and write command.

Function	Access device	Com- mand	Device memory extension specifying item					Specification expression					
			Interval specifica- tion	Extension specifica- tion	Extension specification qualification	Device qualifica- tion	Direct memory specification	Specifi- cation- 1	Specifi- cation- 2	Specifi- cation- 3	Specifi- cation- 4	Specifi- cation- 5	
Batch read	Bit unit	Bit	0401	×	○	×	×	○	○	○	×	×	×
	Word unit	Bit											
Batch write	Bit unit	Bit	1401	×	○	×	×	○	○	○	×	×	×
	Word unit	Bit											
Random read	Word unit	Bit	0403	×	○	○	○	○	○	○	○	○	○
		Word		○									
Test (Random write)	Bit unit	Bit	1402	×	○	○	○	○	○	○	○	○	○
	Word unit	Bit		Word									
Monitor data registration	Word unit	Bit	0801	×	○	○	○	○	○	○	○	○	○
		Word		○									
Monitor	Word unit	—	0802	×	×	×	×	×	—	—	—	—	—
Multiple block batch read	Word unit	Bit	0406	×	○	×	×	○	○	○	×	×	×
		Word											
Multiple block batch write	Word unit	Bit	1406	×	○	×	×	○	○	○	×	×	×
		Word											

↑ Bit : Bit device ○ : Specifying possible × : Specifying not possible
Word : Word device

(b) Device memory extension specification existence mixed specification

When using the following functions, multiple device names can be specified in the command message. In this case, when specifying extensions for a device memory, specify the extensions for all the devices specified in the command message.

Extension specified and extension not specified cannot be mixed in the same device memory.

- Random read function (command : 0403)
- Test (random write) function (command : 1402)
- Monitor data registration function (command : 0801)
- Multiple block batch read function (command : 0406)
- Multiple block batch write function (command : 1406)

(c) Access to special functions module

① The read/write of the buffer memory of the special function module by the device memory extension specification is conducted using the above QE71 commands for the special function modules installed in the following stations.

- QnACPU+QE71 connected to the remote node.
- QnACPU station in the MELSECNET/10

② Refer to Item 10.3 for information regarding reading from or writing to special function modules installed in stations other than those listed above.

10.3 Buffer Memory Read/Write

This section explains the functions used to read/write data from remote nodes to the buffer memories of special function modules installed in QnA PLC station (local station) or PLC stations (remote station) in data link systems or network systems in which a QE71 is not installed.

The PLC stations for which reading from and writing to special function module buffer memories is possible and the functions and commands used are shown below.

The stations and modules corresponding to the access 1 to access 6 shown in the table and the corresponding read/write methods and functions and commands are as follows.

	Read/write target			Read/write methods				
	NO.	Target station	Target module	QnA extension specification (Item 10.2.11)	QE71 commands		E71 commands "OE", "OF"	
					"0601", "1601"	"0613", "1613"		
Access 1 (local station)	①	Remote node connection station	QnACPU station	QE71	×	×	○	×
			Remote station					
Access 2 (local station)	②	Remote node connection station	QnACPU station	Special function module (excluding QE71)	○	○	×	×
Access 3 (remote station)	④	Station on MELSECNET/10	QnACPU station	Special function module (including QE71)	○	○	×	×
Access 4 (remote station)	⑥	Station on MELSECNET/10	PLC CPU station other than QnACPU	Special function module (including QE71)	×	×	×	×
Access 5 (remote station)	⑧	Station on MELSECNET (II), /B	QnACPU station		×	×	×	×
Access 6 (remote station)	⑨	Station on MELSECNET (II), /B	PLC CPU station other than QnACPU		×	×	×	Local station: ○ Master station: ×
				Remote station		×	×	×

○: Read/write possible X: Read/write not possible

1

Stations and modules corresponding to access 1 to access 6 shown in the table

- Access 1 (local station)
 - ① QE71 connected to a remote node
- Access 2 (local station)
 - ② Special function module installed in a QE71 connected to a remote node.
 - ③ Special function module installed in a MELSECNET/10 remote station installed in a QE71 connected to a remote node.
- Access 3 (remote station)
 - ④ Special function module installed in a QnACPU station on a MELSECNET/10.
 - ⑤ Special function module installed in a QnA supporting remote station on the MELSECNET/10.
- Access 4 (remote station)
 - ⑥ Special function module installed in a station other than a QnACPU on the MELSECNET/10.
 - ⑦ Special function module installed in a AnU supporting remote station on the MELSECNET/10.
- Access 5 (remote station)
 - ⑧ Special function module installed in the QnACPU station on the MELSECNET (II), MELSECNET (B).

- Access 6 (remote station)
 - ⑨ Special function module installed in a station other than the QnACPU on the MELSECNET (II), MELSECNET/B.
 - ⑩ Special function module installed in a AnA/AnU supporting remote station on the MELSECNET (II), MELSECNET/B.

2**Functions and commands corresponding to the read/write methods shown in the table**

- QnA extension specification: Conduct read/write using the device memory extension specification shown in Item 10.2.11.
- QE71 commands
 - “0613”, “1613” : Conduct read/write using the QE71 commands “0613” and “1613” shown in Item 10.3.1.
 - “0601”, “1601” : Conduct read/write using the QE71 commands “0601” and “1601” shown in Item 10.3.2.
- E71 commands
 - “OE”, “OF” : Conduct read/write using the E71 “OE” and “OF” commands shown in Item 9.2.2.

For details regarding commands refer to the following manuals.

- Ethernet Interface Module User's Manual SH-3598
- For A Ethernet Interface Module User's Manual SH-080192

Point

The special function module buffer memories, including QE71, have read/write possible areas, read only areas, write only areas, and OS user use not possible areas in each module. Execute this function in accordance with the explanations given in each module manual. Conducting a mistaken read or write will cause an error in the PLC CPU or the special function module.

10.3.1 Ethernet Interface Module Buffer Memory Read and Write

This function reads and writes data to and from the buffer memory of the QE71 connected to the remote node.

When a read or write request is output from a remote node, exchange between the remote node and the QE71 is conducted by this function without waiting for PLC CPU END processing, so the transmission time's T1 shown in Item 9.1 is always 0.

The PLC CPU reads and writes the buffer memory data (data exchange with the remote node) using FROM/TO instruction.

Following is an explanation using an example control procedure for this function.

10.3.1.1 Command and Buffer Memory

This section explains the commands and buffer memory addresses specified by the control procedure when reading from and writing to the QE71 buffer memory is conducted.

1 Command

Functions	Command (Subcommand) * For ASCII code: Specify each ASCII code. For binary code: Specify each numeral as hexadecimal numeral.	Description of processing	Number of points processed per 1 exchange		PLC CPU state			Reference Item
			Access station-1 (Refer to Item 9.2.1 ^{*7})	Access station-2 (Refer to Item 9.2.1 ^{*8})	During STOP	During RUN		
						Write possible setting	Write not possible setting	
Batch read	0 6 1 3 (0 0 0 0)	Reads the data from the buffer memory.	480 words (960 bytes)	(Not possible)	○	○	○	Item 10.3.1.2
Batch write	1 6 1 3 (0 0 0 0)	Writes the data to the buffer memory.			○	○	○	Item 10.3.1.3

○ in the PLC CPU state column of the above table shows that execution is possible.

2 Buffer memory and access unit

The buffer memory address specified by this function uses the buffer memory list addresses shown in Item 3.7.

One address is configured of 1 word (16 bits).

This function reads and writes in word units.

Point

- (1) The buffer memory applications are limited.
The QE71 will not operate correctly if used for applications other than those explained in this manual.
- (2) How to read and write the buffer memory of the QE71 at remote stations are described in Item 10.3.2.

3 Character area contents

Following is an explanation of the character area contents when read and write of the QE71's buffer memory is performed by a remote node.

(a) Head address

This data is used to specify the head area address of the read range (or write range) of the data.

① Data exchange using ASCII code

The head area address 0H to 3E7FH (0 to 15999) is converted to ASCII code 8 digits (hexadecimal) and transmitted.

(Example) when the head area address is E3H it becomes "000000E3" and is transmitted in the order from "0."

② Data exchange using binary code

The head area address 0H to 3E7FH (0 to 15999) that is shown as a 4 byte numerical value is transmitted from the Low byte (L : bits 0 to 7).

(Example) when the head area address is E3H it becomes "000000E3H" and is transmitted in order from "E3."

(b) Word length

This data is used to specify the number of addresses (number of words) for the read range (or write range) of the data.

① Data exchange using ASCII code

The number of addresses 1H to 1E0H (1 to 480) is converted to ASCII code 4 digits (hexadecimal) and transmitted from the first digit.

② Data exchange using binary code

The number of addresses 1H to 1E0H (1 to 480) that is shown as a 2 byte numerical value is transmitted from the Low byte (L : bits 0 to 7).

Remarks

Specify the following data specification items in the message as the data for the local station.

Network No. : 00H PLC No : FFH

(ASCII code exchange)

QnA header																
Network No.		PLC No.		Fixed value				Request data length		CPU monitoring timer						
H	L	H	L	H	-	-	L	H	-	-	L	H	-	-	L	
0	0	F	F	0	3	F	F	0	0	0	1	8	0	0	1	0
30h	30h	46h	46h	30h	33h	46h	46h	30h	30h	30h	31h	38h	30h	30h	31h	30h

(Binary code exchange)

QnA header																
Network No.		PLC No.		Fixed value				Request data length		CPU monitoring timer						
L	H	L	H	L	H	L	H	L	H	L	H	L	H	L	H	
00h	FFh	FFh	03h	00h	0Ch	00h	10h	00h								

10.3.1.2 Buffer Memory Read (Command : 0613)

This section uses an example to explain the QE71's buffer memory batch read control procedure.

(Control procedure)

- 1 When the buffer memory address 78H to 81H (120 to 129) area contents are read in 10 word divisions while exchanging using ASCII code.

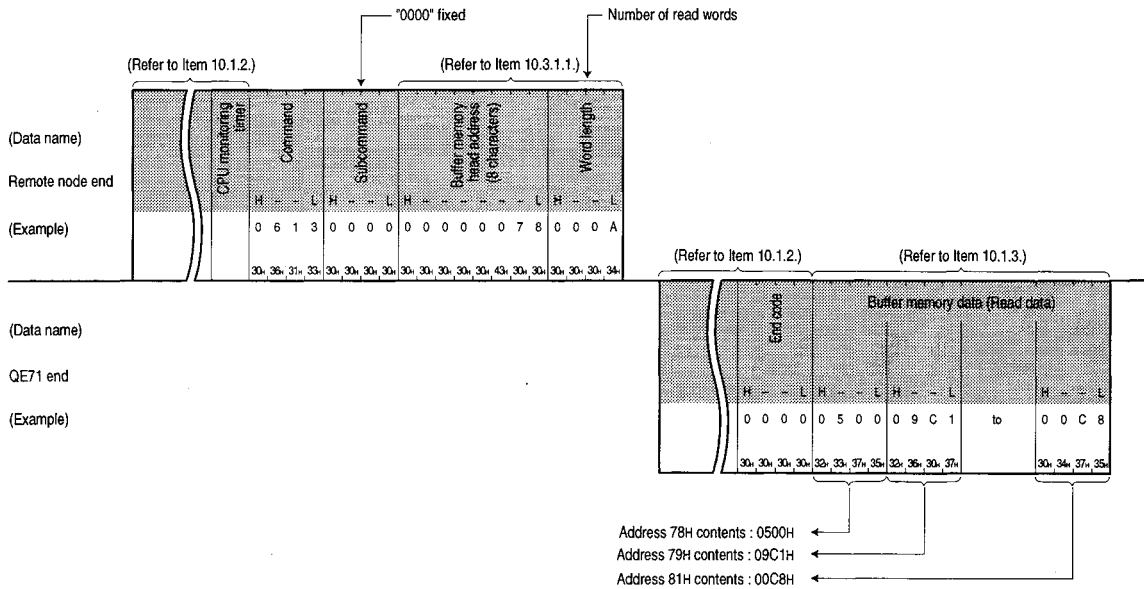

2 When the buffer memory address 78H to 81H (120 to 129) area contents are read in 10 word divisions while exchanging using binary code

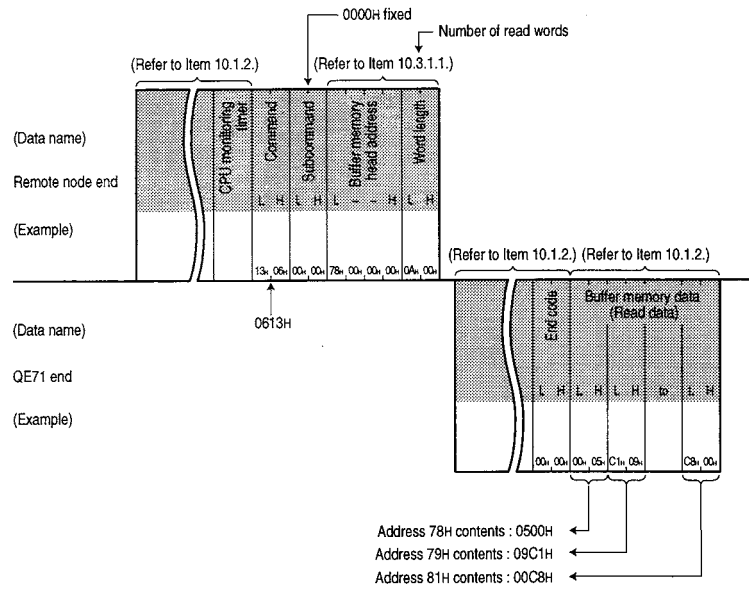

Point

Set the head address and word length using the following range.

- Head address 0H ≤ head address ≤ 3E7FH
- Word length 1H ≤ word length ≤ 1E0H (480)
- Access range (head address + word length - 1) ≤ 3E7FH

10.3.1.3 Buffer Memory Write (Command : 1613)

This section uses an example to explain the QE71 buffer memory batch write control procedures.

(Control procedure)

1 When writing data to the buffer memory address 2680H to 2683H (9856 to 9859) area in 4 word divisions when exchanging using ASCII code

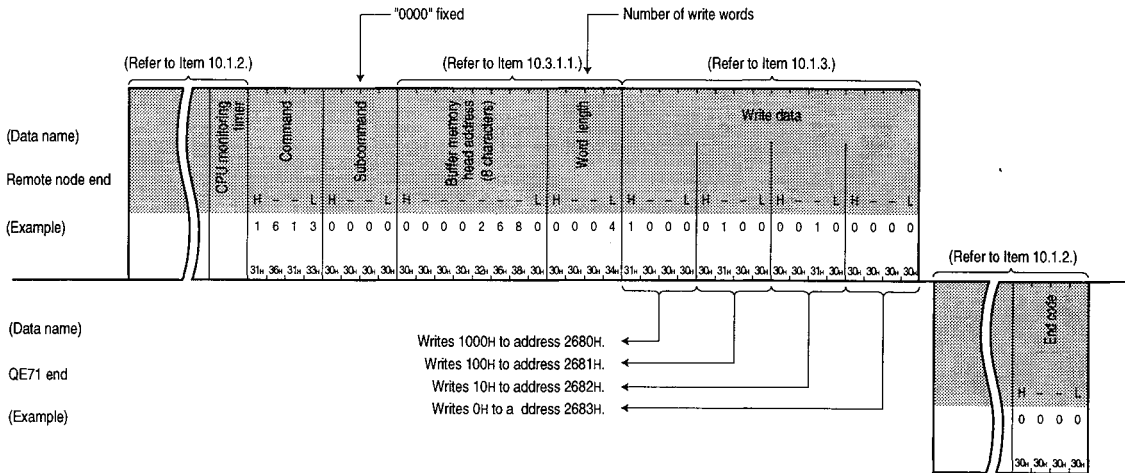

2 When writing data to the buffer memory address 2680H to 2683H (9856 to 9859) area in 4 word divisions when exchanging using binary code

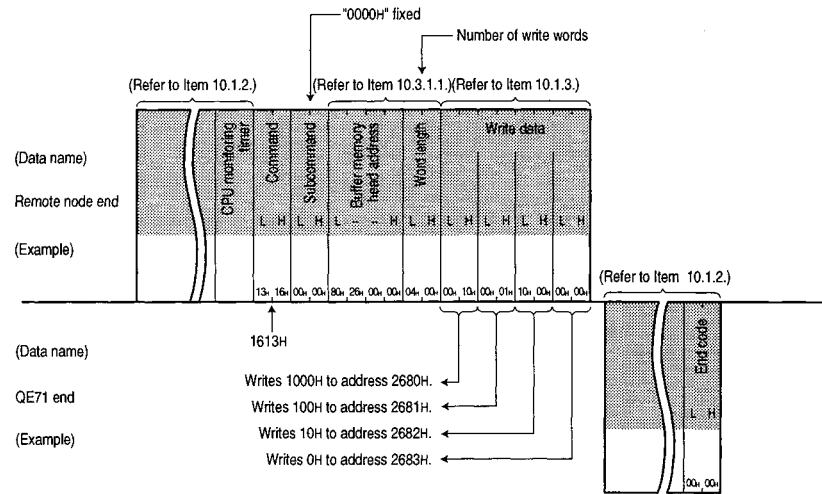

Point

Set the head address and word length using the following range.

- Head address 0H ≤ head address ≤ 3E7FH (15999)
- Word length 1H ≤ word length ≤ 1E0H (480)
- Access range (head address + word length - 1) ≤ 3E7FH (15999)

10.3.2 Special Function Module Buffer Memory Read and Write

This manual uses an example to explain the control method when reading and writing data to and from the buffer memory of a remote station special function module (including QE71).

This command accesses the buffer memory of special function modules using byte units.

10.3.2.1 Commands and Buffer Memory

This section explains the commands and buffer memory addresses specified by the control procedure when conducting reading and writing of the special function module buffer memory.

1 Command

Functions	Command (Subcommand) * For ASCII code: Specify each ASCII code. For binary code: Specify each numeral as hexadecimal numeral.	Description of processing	Number of points processed per 1 exchange		PLC CPU state			Reference Item
			Access station-1 (Refer to Item 9.2.1 ^{*7})	Access station-2 (Refer to Item 9.2.1 ^{*8})	During STOP	During RUN		
						Write possible setting	Write not possible setting	
Batch read	0 6 0 1 (0 0 0 0)	Reads the data from the buffer memory.	480 words (960 bytes)	(Not possible)	○	○	○	Item 10.3.2.3
Batch write	1 6 0 1 (0 0 0 0)	Writes the data to the buffer memory.			○	○	○	Item 10.3.2.4

○ in the PLC CPU state column of the above table shows that execution is possible.

2 Buffer memory and access units

The buffer memory addresses specified in this function is specified by the method shown in (3) (a). One address is configured of 1 word (16 bits), but this function conducts reading and writing in byte units.

3 Character section contents

This section explains the character section contents when the remote node conducts reading or writing of the special function module buffer memory.

(a) Head address

This data is used to specify the head area address of the range that will read (or write) the data. The head address specification method is as shown in (3). The accessible modules and buffer memory head addresses are shown in Item 10.3.2.2.

① When exchanging data using ASCII code

The head area address is converted to ASCII code 8 digits (hexadecimal), used, and transmitted from the first digit (0).

Example: When the head address is 1E1H Becomes "000001E1" and is transmitted from "0."

② When exchanging data using binary code

The 4 byte numeral shown in the head area address is used and transmitted from the low byte (L: Bit 0 to 7).

Example: When the head area address is 1E1H Becomes 000001E1H and is transmitted from E1H.

- ③ This shows the head address specification method when reading from or writing to the special function module buffer memory. The special function module buffer memory is configured of one address of 16 bits (1 word) and reading and writing between the PLC CPU and the special function module is conducted using FROM/TO commands.

When reading from or writing to the buffer memory of a special function module from a remote node via the QE71 using the commands shown in Item 10.3.2, the read/write is conducted in one address=8 bits (1 byte) units. The address (hexadecimal) specified by the remote node is specified from the FROM/TO command address to the following converted address.

Head address (hexadecimal)	=	[(FROM/TO command address x 2)] is made to hexadecimal	+	buffer memory head address
-------------------------------	---	---	---	----------------------------

This section uses AD61 as an example to explain the data format when accessing the special function module buffer memory from a remote node.

Example: When model AD61 high speed counter module's FROM/TO command address 1 (CH.1 preset value) is specified

Head address	=	FROM/TO command address	x	2	+	Buffer memory head address
82H		2H				80H

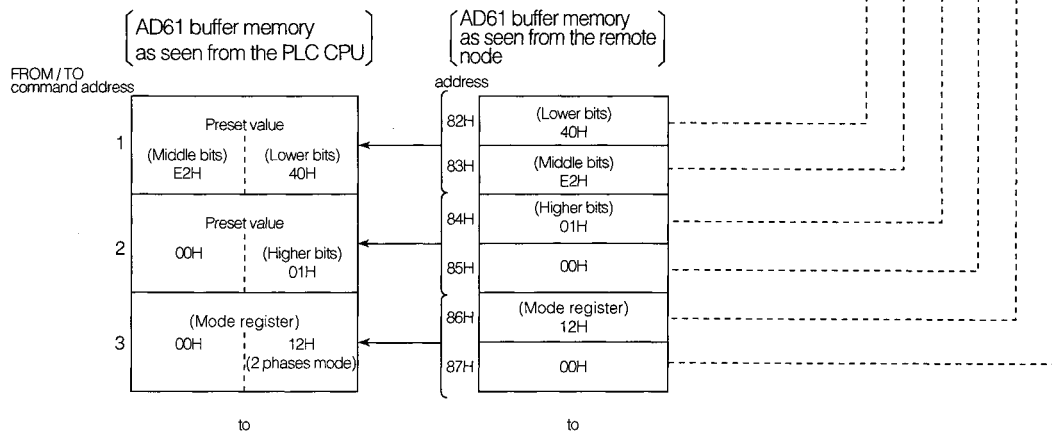
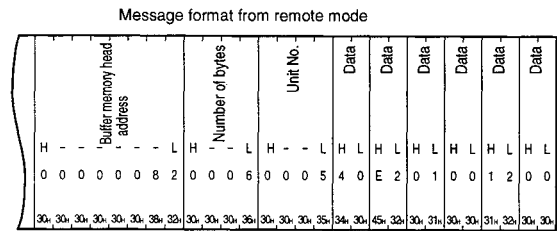

Point
The head address (80H in the case of the above AD61) of the special function module buffer memory when "head address" is specified in the text is shown in Item 10.3.2.2.

(b) Number of bytes

This data is used to specify the number of addresses x 2 (number of bytes) of the range that reads (writes) the data and is specified in an even number of bytes.

① When exchanging data using ASCII code

The number of addresses x 2 (2 to 960) is converted to ASCII code 4 digits (hexadecimal), and transmitted from the first digit (0).

② When exchanging data using binary code

The 2-byte number shown in the number of addresses x 2 (2 to 960) is used and transmitted from the low byte (L: Bit 0 to 7).

(c) Module No.

This data is used to specify the special function module from which data will be read from or written to. The module No. specification method is shown in ③. The accessible modules, buffer memory head addresses, and the module No. when the accessible module is installed in slot 0 is shown in Item 10.3.2.2.

① When exchanging data using ASCII code

The first 3 digits of the corresponding special function module I/O signal expressed in 4 digits is converted to ASCII code 4 digits (hexadecimal), used, and transmitted from the first digit.

Example: When the special function module I/O signal is 0080H to 009FH

The head I/O No. becomes "0008" and is transmitted in order from "0."

② When exchanging data using binary code

The 2-byte number of the first 3 digits when the corresponding special function module I/O signal is expressed in 4 digits is used and transmitted in order from the low byte (L: Bit 0 to 7) and high byte (H: Bit 8 to 15).

Example: When the special function module I/O signal is 0080H to 009FH

The head I/O No. becomes 0008H and is transmitted in order from 08H, 00H.

③ This shows the module No. specification method when conducting read or write of the special function module function module buffer memory.

- The module No. is specified by the head I/O signal allocated to the special function module for the installed station.
- Specified by the head I/O signal in the slot of the special function module when the special function module occupies slot 2.

(When the special function module occupies slot 1)

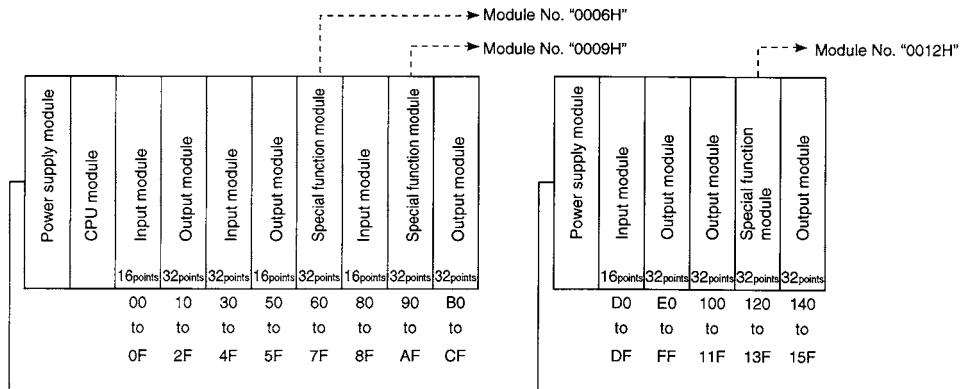

(When the special function module occupies slot 2)

The special function module that occupies slot 2 determines the number of occupied slots for each module. The module No. is the first 3 digits when the header address of the slot allocated as a special function module is expressed in 4 digits. For information regarding the allocation for each module slot, refer to the corresponding special function module user's manual.

- Ⓐ For modules for which the first half of the slots are allocated as vacant slots.
(AD72, A84AD, etc.)

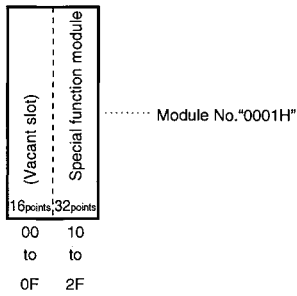

- Ⓑ For modules for which the last half of the slots are allocated as vacant slots.
(A61LS, etc.)

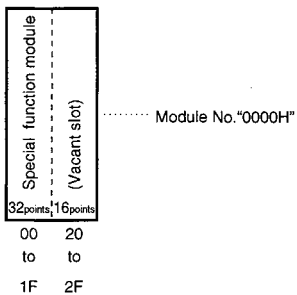

- Ⓒ For modules for which special function module allocation and I/O allocation are mixed.
(A81CPU, etc.)

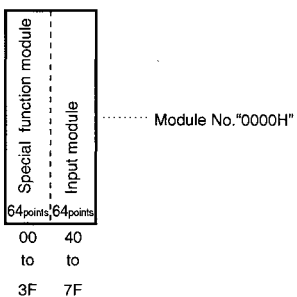

(For a network system remote I/O station special function modules)

The MELSECNET/10 remote I/O station special function module's module No. are the first 3 digits of the 4 digits that express the head address of the below listed I/O addresses as seen from the remote I/O station. Set to the I/O address as seen from the remote I/O station regardless of the common parameter contents specified by the MELSECNET/10 remote I/O network master station.

		Module No. "0003H"				
(I/O address as seen from the remote I/O station)		Y	Y	X/Y	Y	Y
		00	20	30	50	70
	to	to	to	to	to	
	1F	2F	4F	6F	8F	
No. 1 remote I/O station	Power supply module					
	AJ72LP25					
	Output module	32				
	Output module		16			
	Special function module			32		
	Output module				32	
Output module					32	
(I/O address from the common parameter)		Y	Y	X/Y	Y	Y
		400	420	430	450	470
	to	to	to	to	to	
	41F	42F	44F	46F	48F	

The module No. of the special function module occupying slot 2 is set using the method shown on the previous page (for special function module occupying slot 2).

(d) Reading data and writing data

This is the order of the byte number portion of data (maximum 960 bytes) shown in (b) above when data is read from or written to the special function module.

① When exchanging data using ASCII code

The data code is converted into the first 2 digits (hexadecimal) of each ASCII code, used, and transmitted from the first digit.

Example: When the read data/written data is 12H

The read data, written data becomes "12" and is transmitted from "1."

② When exchanging data using binary code

The data code is transmitted from the header section.

10.3.2.2 Accessible Special Function Modules

Following is shown the special function modules that can read from and write to the buffer memory using the QE71 commands (0601, 1601) and the head address and module No. specified in the message.

Remarks

The buffer memory head address and module No. when installed in slot 0 in the table below use the head address and module No. specified in the message.

Special function module model name	Buffer memory head address (hexadecimal)	Module No. when installed in slot 0
Model AD61 (S1) high speed counter module	80H	0000H
Model A616AD analog-digital conversion module	10H	
Model A616DAI/DAV digital-analog conversion module	10H	
Model A616TD temperature-digital conversion module	10H	
Model A62DA (S1) digital-analog conversion module	10H	
Model A68AD (S2) analog-digital conversion module	80H	
Model A68ADN analog-digital conversion module	80H	
Model A68DAV/DAI (S1) digital-analog conversion module	10H	
Model A68RD3/4 temperature-digital conversion module	10H	
Model A84AD analog-digital conversion module	10H	
Model A81CPU PID controller module	200H	0000H
Model A61LS position detection module	80H	
Model A62LS (S5) position detection module	80H	0001H
Model AJ71PT32 (S3)/AJ71T32-S3 MELSECNET/MINI master module	20H	0000H
Model AJ61BT11 CC-Link system master-local module	2000H (*2)	
Model AJ71C22 (S1) multiple drop link module	1000H	
Model AJ71C24 (S3, S6, S8) computer link module	1000H	
Model AJ71UC24 computer link module	400H	
Model AD51 (S3) intelligent communication module	800H	0001H
Model AD51H (S3) intelligent communication module	800H	
Model AJ71C21 (S1) terminal interface module	400H	0000H
Model AJ71B62 (S3) B/NET interface module	20H	
Model AJ71P41 SUMINET interface module	400H	
Model AJ71E71 (S3) Ethernet interface module	400H (*3)	
Model AD51FD (S3) external problem diagnosis module	280H	0001H
Model AD57G (S3) graphic controller module	280H	
Model AS25VS vision sensor module	100H	
Model AS50VS vision sensor module	100H	
Model AS50VS-GN vision sensor module	80H	
Model AD59 (S1) memory card interface module	1800H (*1)	0000H
Model AJ71ID1 (2) -R4 ID interface module	280H	
Model AD70 (D) (S2) positioner module	80H	

Special function module model name	Buffer memory header address (hexadecimal)	Model No. when installed in slot 0
Model AD71 (S1/S2/S7) positioner module	200H	0000H
Model AD72 positioner module	200H	0001H
Model AD75P1/P2/P3 (S3), AD75M1/M2/M3 positioner module	800H	0000H
Model AJ61QBT11 CC-Link system master · local module	2000H	
Model AJ71QC24 (N)(R2, R4) serial communication module	4000H	
Model AJ71QE71 (B5) Ethernet interface module	4000H	
Model A1SD61, A1SD62 (E/D(S1)) high speed counter module	10H	
Model A1S62DA digital-analog conversion module	10H	
Model A1S62RD3/4 temperature-digital conversion module	10H	
Model A1S64AD analog-digital conversion module	10H	
Model A1SJ71 (U) C24-R2 computer link module	400H	
Model A1SJ71 (U) C24-PRF computer link module	400H	
Model A1SJ71 (U) C24-R4 computer link module	400H	
Model A1SJ71E71-B2/B5 (S3) Ethernet interface module	400H (*3)	
Model A1SD51S intelligent communication module	800H	
Model A1SJ71ID1 (2) -R4 ID interface module	280H	
Model A1SD70 single axis positioner module	80H	
Model A1SD71-S2/S7 positioner module	200H	
Model A1SD75P1/P2/P3 (S3), A1SD75M1/M2/M3 positioner module	800H	0000H
Model A1S63ADA analog I/O module	10H	
Model A1S64TCTT (BW)-S1 temperature adjustment module	20H	
Model A1S64TCRT (BW)-S1 temperature adjustment module	20H	
Model A1S62TCTT (BW)-S2 temperature adjustment module	20H	
Model A1S62TCRT (BW)-S2 temperature adjustment module	20H	
Model A1S68DAV/DAI digital-analog conversion module	20H	
Model A1S68AD analog-digital conversion module	20H	
Model A1S68TD temperature-digital conversion module	20H	
Model A1SJ71PT32-S3 MELSECNET/MINI master module	20H	
Model A1SJ61BT11 CC-Link system master-local module	2000H (*2)	
Model A1SJ71QC24 (N) (R2) serial communication module	4000H	
Model A1SJ71QE71-B2/B5 Ethernet interface module	4000H	
Model A1SJ61QBT11 CC-Link system master · local module	2000H	

*1 It is possible to read/write only the memory card access memory area by switching the memory card bank using the input/output signal Y10, Y11 between the PLC CPU and the AD59 (S1).

*2 It is possible to read/write the buffer memory of the corresponding bank by switching banks of the buffer memory by the input/output signal Y1C/Y1D between the PLC CPU and AJ61BT11/ A1SJ61BT11.

*3 It is possible to read/write the fixed buffer of the corresponding bank and the random access buffer by switching banks of the buffer memory by the input/output signal Y1C between the PLC CPU and E71.

10.3.2.3 Special Function Module Buffer Memory Read (Command: 0601)

This section uses an example to explain the special function module buffer memory read control procedure.

(Control procedure)

- (1) When the I/O No. reads the 30H to 4FH (module No.: 03H) model AD61 high speed counter buffer memory address 4H to 5H's 4-byte portion through exchange using ASCII code.

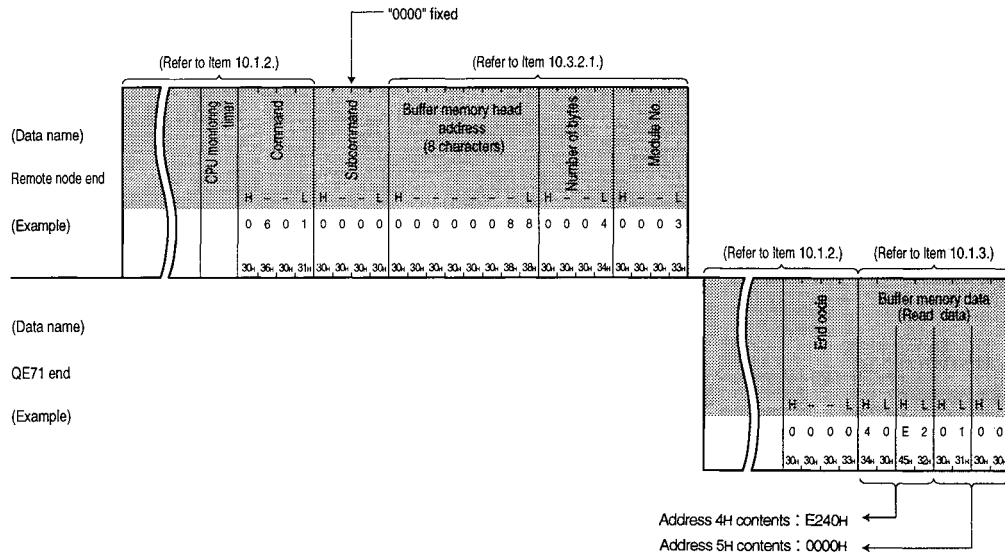

(2) When the I/O No. reads the 30H to 4FH (module No.: 03H) model AD61 high speed counter buffer memory address 4H to 5H's 4-byte portion through exchange using binary code.

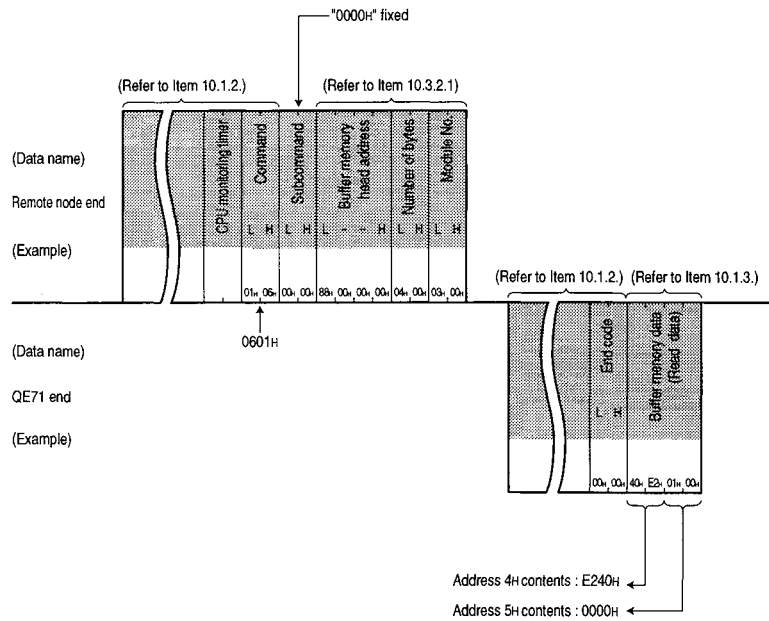

Point

- (1) Specify the head address and number of bytes in the following ranges.
 - Head address Corresponding special function module address range
 - Number of bytes $2 (2H) \leq \text{number of bytes} \leq 960 (3C0H)$
- (2) Depending on the special function module, the contents of 1 data unit will vary by 2 to 3 bytes, so refer to the module's manual when specifying the number of bytes and the write data.

10.3.2.4 Special Function Module Buffer Memory Write (Command: 1601)

This section uses an example to explain the special function module buffer memory write control procedure.

(Control procedure)

- (1) When the I/O No. writes the 30H to 4FH (module No.: 03H) model AD61 high speed counter buffer memory address 1H to 2H's 4-byte portion through exchange using ASCII code.

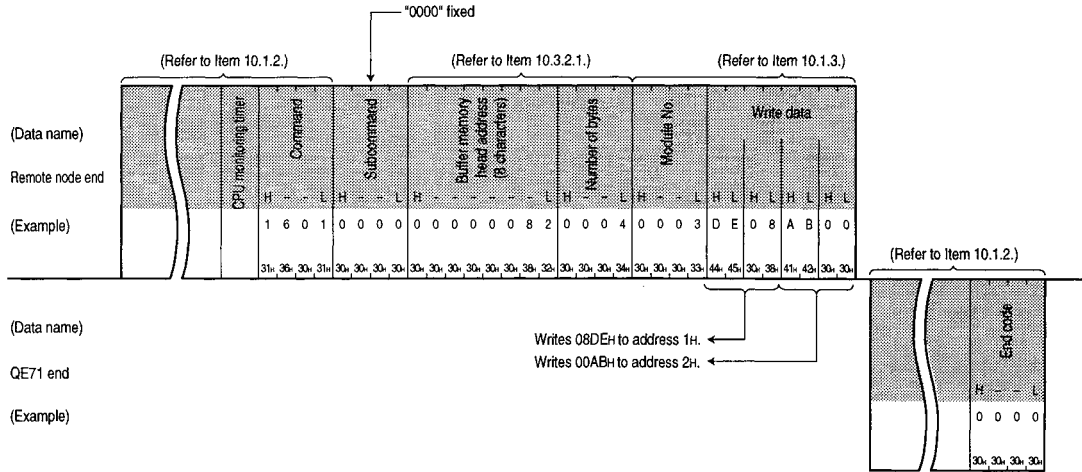

(2) When the I/O No. writes 30H to 4FH (module No.: 03H) model AD61 high speed counter buffer memory address 1H to 2H's 4-byte portion through exchange using binary code.

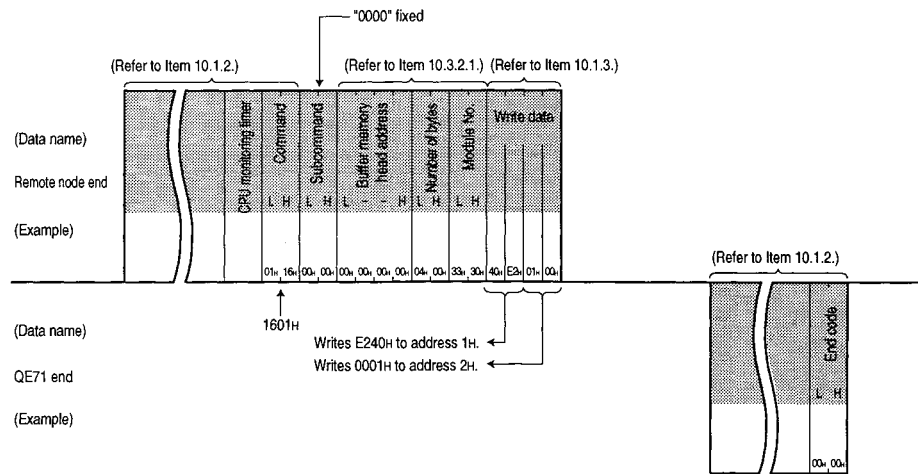

Point

- (1) Specify the head address and number of bytes in the following ranges.
 - Head address Corresponding special function module address range
 - Number of bytes $2 (2H) \leq \text{number of bytes} \leq 960 (3C0H)$
- (2) Depending on the special function module, the contents of 1 data unit will vary by 2 to 3 bytes, so refer to the module's manual when specifying the number of bytes and the write data.

10.4 PLC CPU State Control

This function conducts remote RUN, STOP, PAUSE, RESET, of the QnACPU from the remote node and clears the QnACPU device memory.

This section uses an example to explain this function's control procedure.

Point

(1) When PLC CPU state control is conducted for the local station's (QE71 installed station) PLC CPU, it is recommended that it is performed under the following conditions.

- ① Boot up the QE71 using the automatic start mode and the PLC CPU state is controlled using the QE71's automatic open UDP port. (Refer to Items 5.1 2, 5.2.1 and 5.7)
- ② Control the PLC CPU status with data exchange function when the PLC CPU is in the STOP status. (Refer to Chapter 16.)

When the user uses the open processing TCP/UDP port to conduct PLC CPU state control without above procedure, the output signal from the PLC CPU to the QE71 will be turned off if a remote STOP is conducted, and this will disconnect (close procedure) the communication line.

For this reason all data exchange thereafter will stop including PLC CPU state control from the remote node.

When PLC CPU state control is executed for a remote station PLC CPU via MELSECNET, it can be executed regardless of the above conditions.

(2) How to control the QnACPU status at remote stations from the local station QnACPU are described in Chapter 14.

10.4.1 Command and Control Description and Character Area Contents

This section explains about the commands, control contents, and character portion in the control procedure when PLC CPU state control is conducted.

1 Command

Functions	Command (Subcommand) * For ASCII code: Specify each ASCII code. For binary code: Specify each numeral as hexadecimal numeral.	Description of processing	Number of points processed per 1 exchange		PLC CPU state			Reference Item			
			Access station-1 (Refer to Item 9.2.1*7)	Access station-2 (Refer to Item 9.2.1*8)	During STOP	During RUN					
						Write possible setting	Write not possible setting				
Remote RUN	1 0 0 1 (0 0 0 0)	Request remote RUN (operation execute).	(For 1 station)	(Not possible)	○	○	○	Item 10.4.2			
Remote STOP	1 0 0 2 (0 0 0 0)	Request remote STOP (operation stop).						Item 10.4.3			
Remote PAUSE	1 0 0 3 (0 0 0 0)	Request remote PAUSE (operation stop). (Holds the output state)						Item 10.4.4			
Remote Latch Clear	1 0 0 5 (0 0 0 0)	Request remote latch clear (Device memory clear) in the STOP state.						○	×	×	Item 10.4.5
Remote RESET	1 0 0 6 (0 0 0 0)	Request remote RESET (operation execute start) in the STOP state.						○	×	×	Item 10.4.6

○ in the PLC CPU state column of the above table shows that execution is possible.

2 Control contents

(a) The QnACPU state's from the state control from the remote node and the QnACPU front RUN/STOP key switch conditions is shown in the following table.

		QnACPU front key switch state	
		RUN	STOP
Request contents from remote node	Remote RUN	RUN	STOP
	Remote STOP	STOP	STOP
	Remote PAUSE	PAUSE	STOP
	Remote Latch Clear	[Can be executed while the QnACPU is in the STOP (operation stop) state regardless of the key switch state.]	
	Remote RESET		

Point

- (1) The remote information will be deleted if the QnACPU's power is turned from off to on or reset after remote RUN, STOP, or PAUSE is conducted from a remote node.
- (2) State control from a remote node cannot be conducted when a system protect (system protect switch SW5 is on) is applied to the QnACPU. For each request an end code is returned at the time of error is returned.

3

Character area contents

This section explains the character area contents when the QnACPU state control is conducted from a remote node.

(a) Mode

This data is used to force execute remote RUN and remote PAUSE.

Forced execution is used to forcibly conduct remote RUN/remote PAUSE from other equipment when trouble has occurred in the QE71 or other equipment that is requesting QnACPU remote STOP/PAUSE and it is no longer possible to conduct remote RUN/remote PAUSE for the state controlled QnACPU.

① Data exchange using ASCII code

The following specified values are converted to ASCII code 4 digits (hexadecimal) and is transmitted from the first digit.

② Data exchange using binary code

The following 2-byte numerical value is transmitted from the Low byte (L : Bits 0 to 7).

③ The mode specification contents are as follows.

Specified value	Description of processing
0001H	Does not conduct forced execution. Does not conduct remote RUN/PAUSE when remote STOP/PAUSE is conducted from another remote node.
0003H	Conducts forced execution. Conducts remote RUN/PAUSE when remote STOP/PAUSE is conducted from another remote node. (Specification possible during remote RUN and remote PAUSE)

④ When state control is conducted using other than remote RUN and remote PAUSE, 0001 or 0001H are transmitted.

(b) Clear mode

This data is used to specify the QnACPU's device memory clear (initialization) processing when QnACPU operation is begun using remote RUN.

After the specified clear is conducted, the QnACPU runs following the parameter setting (PLC file setting to device initial value).

① Data exchange using ASCII code

The following specified values are converted into ASCII code 2 digits (hexadecimal) and transmitted from the first digit.

② Data exchange using binary code

The following 1-byte numerical value is transmitted.

③ The clear mode specified contents are as follows.

Specified value	Description of processing
00H	Device memory is not cleared.
01H	The device memory outside the latch range is cleared.
02H	The entire device memory is cleared including the latch range.

④ Clear mode specification is not required when state control is conducted by other than remote RUN.

(c) Fixed values

① "00" is transmitted when data is exchanged using ASCII code.

② The 1-byte numerical value 00H is transmitted when data is exchanged using binary code.

③ Fixed value specification is not required when state control is conducted using other than remote RUN.

10.4.2 Remote RUN (Command : 1001)

This section uses an example to explain the remote RUN control procedure.

(Control procedure)

1 For remote RUN when exchanging using ASCII code

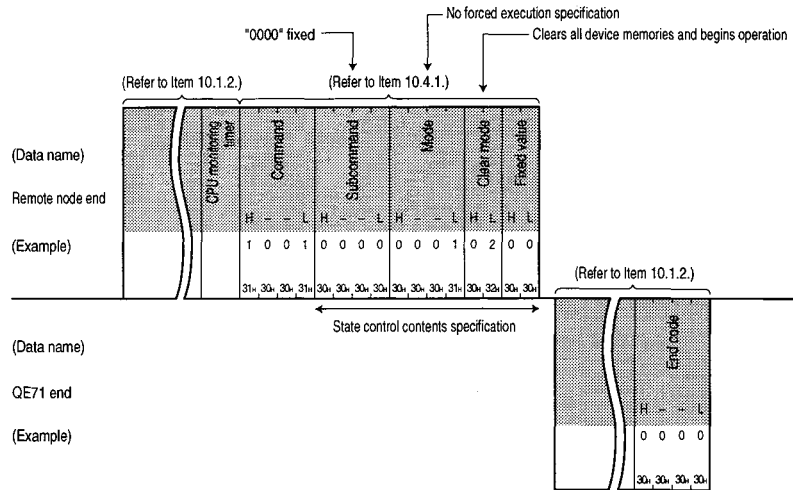

2 For remote RUN when exchanging using binary code

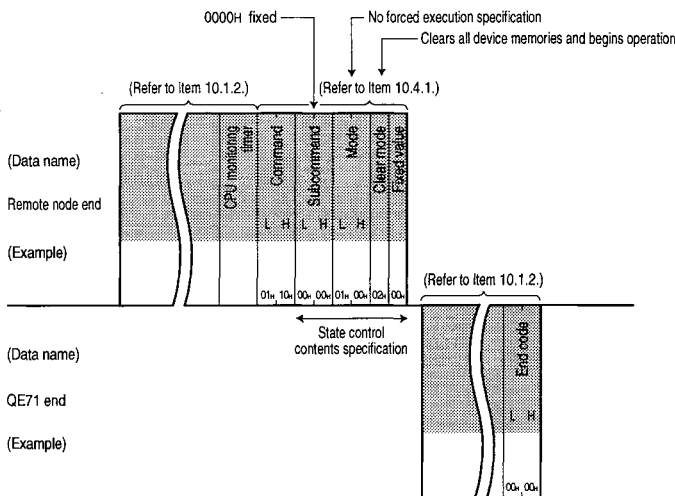

Point
 When the mode is no forced execution specification and the QnACPU has already been remote STOP/PAUSE by another remote node etc., it will not become the RUN state even if remote RUN is executed.

10.4.3 Remote STOP (Command : 1002)

This section uses an example to explain the remote STOP control procedure.

(Control procedure)

1 For remote STOP when exchanging using ASCII code

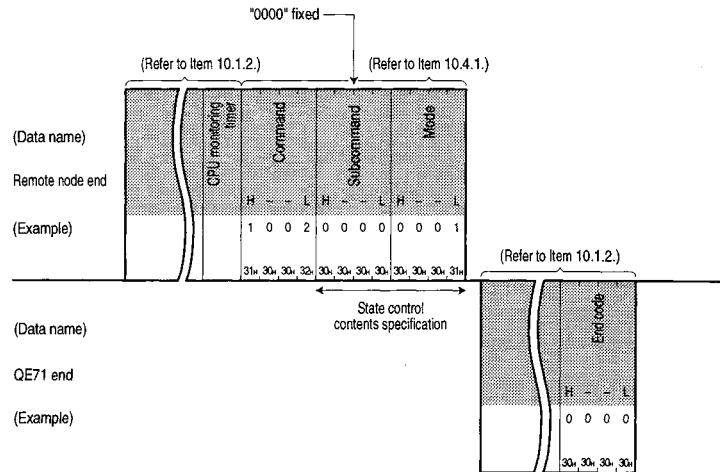

2 For remote STOP when exchanging using binary code

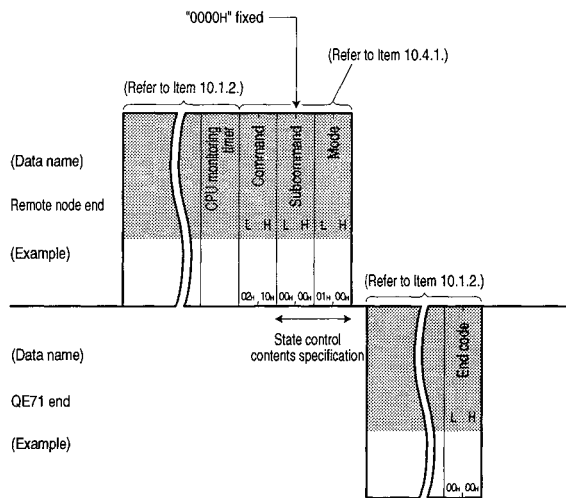

10.4.4 Remote PAUSE (Command : 1003)

This section uses an example to explain the remote PAUSE control procedure.

(Control procedure)

1 For remote PAUSE when exchanging using ASCII code

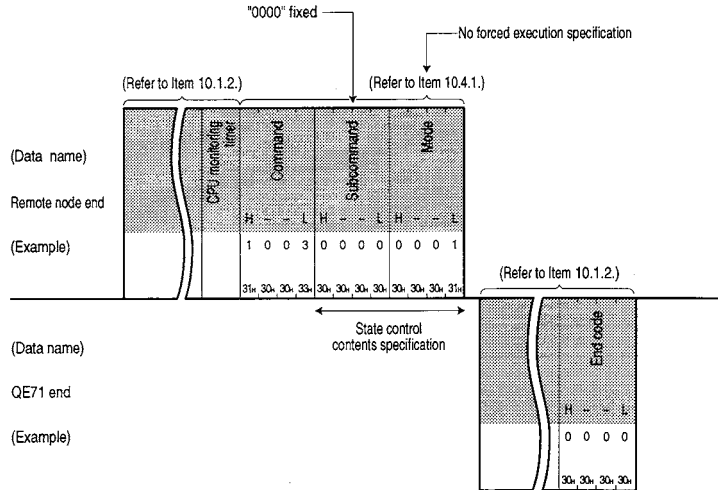

2 For remote PAUSE when exchanging using binary code

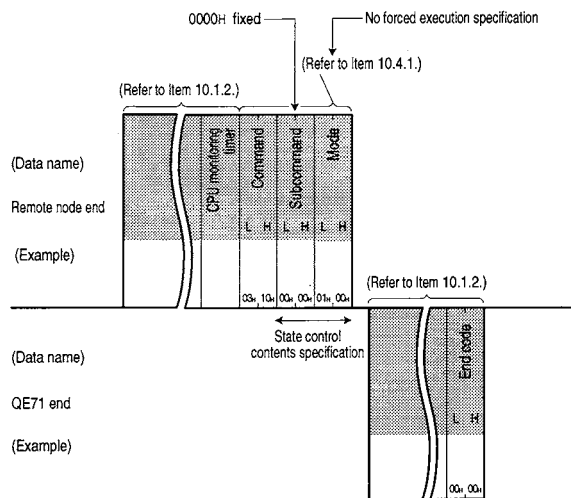

10.4.5 Remote Latch Clear (Command : 1005)

This section uses an example to explain the remote latch clear control procedure.

(Control procedure)

1 For remote latch clear when exchanging using ASCII code

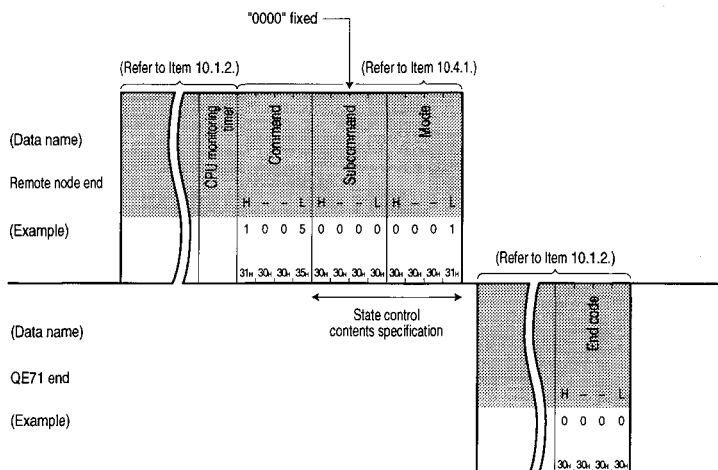

2 For remote latch clear when exchanging using binary code

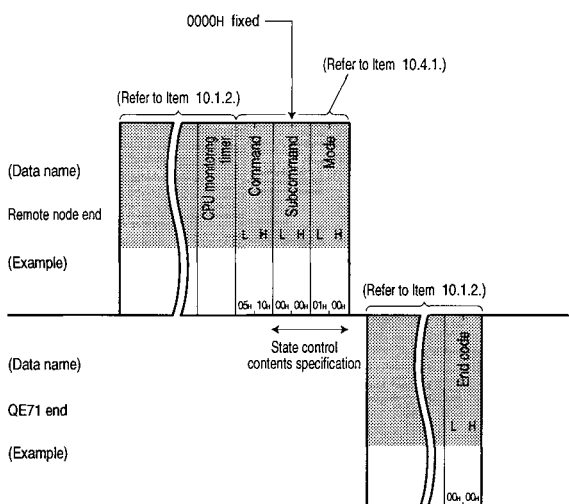

Point

- (1) Conduct remote latch clear after the subject QnACPU has entered the STOP state.
- (2) When the subject QnACPU is in the remote STOP/PAUSE state because of a request from another remote node etc., remote latch clear cannot be conducted. An end code will be returned at the time error occurs.

10.4.6 Remote RESET (Command : 1006)

This section uses an example to explain the remote RESET control procedure.

(Control procedure)

1 For remote RESET when exchanging using ASCII code

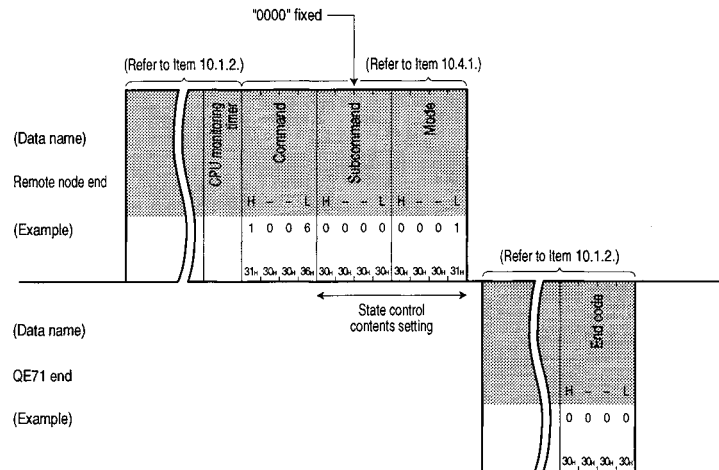

2 For remote RESET when exchanging using binary code

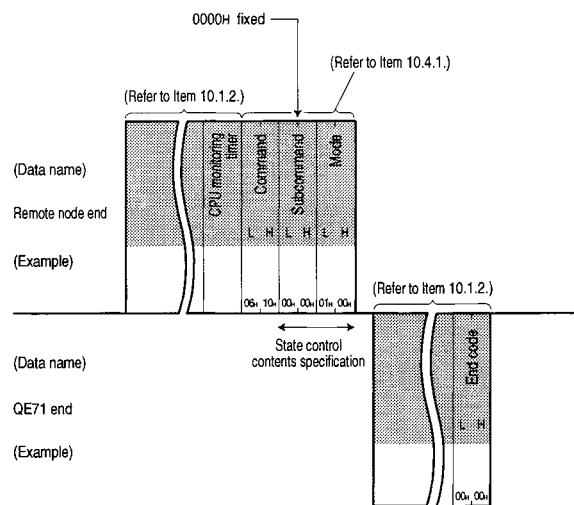

Point

- (1) Use the remote RESET when the subject QnACPU is in the STOP state due to the occurrence of an error.
- (2) Remote RESET can be executed when the QnACPU is operating normally, and when remote RESET is executed the QE71 also resets and reboots at the same state as when the power is turned on.

10.5 Drive Memory Optimization

This function is used for external equipment to conduct the following items for the QnACPU drive in which is stored program files etc. that were written by the parameters and sequence program.

1 Drive memory usage state read

Confirms the drive memory usage state (cluster usage state) of the specified drive.

2 Drive memory optimization

When the valid data written to memory is spread throughout the drive's memory, the memory is optimized in cluster units to increase the continuously vacant area.

This section uses an example to explain the drive memory optimization control procedure.

Point

A cluster is the minimum unit of management when the data that is written to memory is FAT (*1) when files are stored in the drive memory (memory card, etc.). The size of one cluster for the QnACPU's drives are given below.

- Internal RAM : 4096 bytes
- Other than internal RAM : 512 bytes

For example, when data of less than 512 bytes is written to a memory card, one cluster's worth of drive memory is used when the data is written to memory. If from 513 to 1024 bytes of data are written, two clusters worth of drive memory is used to write the data.

*1 FAT (File Allocation Table)

This is the table used by the operating system to manage the position of files in drive memory.

(Drive memory optimization image)

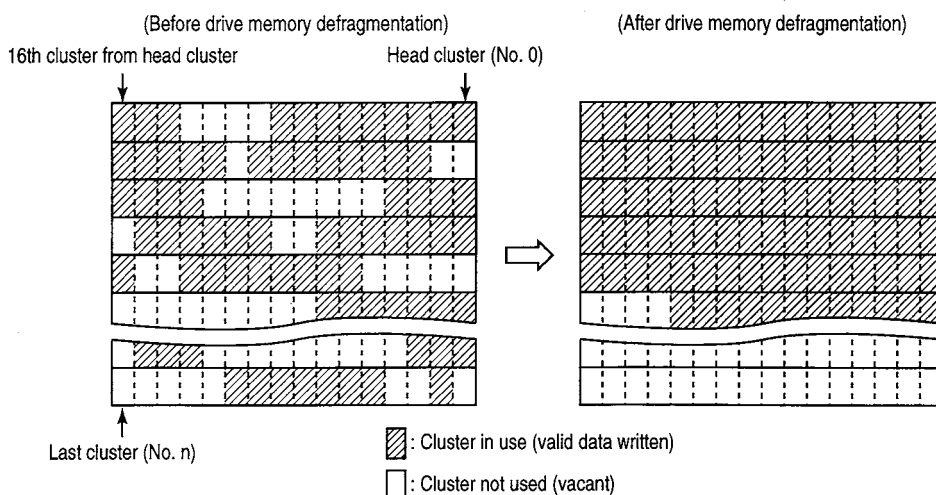

10.5.1 Command and Character Area Contents

This section explains about the commands and character area in the control procedures when drive memory optimization is performed.

1 Command

Functions	Command (Subcommand) * For ASCII code: Specify each ASCII code. For binary code: Specify each numeral as hexadecimal numeral.	Description of processing	Number of points processed per 1 exchange		PLC CPU state			Reference Item
			Access station-1 (Refer to Item 9.2.1*7)	Access station-2 (Refer to Item 9.2.1*8)	During STOP	During RUN		
						Write possible setting	Write not possible setting	
Memory usage state read	0 2 0 5 (0 0 0 0)	Reads the drive cluster usage state.	(256 cluster portion)		○	○	○	Item 10.5.2
Memory optimization	1 2 0 7 (0 0 0 0)	Conducts drive memory optimization to increase continuous vacant area.	(For 1 station)	(Not possible)	○	×	×	Item 10.5.3

○ in the PLC CPU state column of the above table shows that execution is possible.

2 Character area contents

This section explains about the character area contents when a remote node conducts QnACPU drive memory optimization.

(a) Keyword

This is the character series (6 characters) that the user registered in the specified drive and is the data that allows/prohibits access to the drive.

When a keyword is registered, specify the same keyword.

① Data exchange using ASCII code

The keyword registered in the specified drive is transmitted as is.

② Data exchange using binary code

The keyword registered in the specified drive is converted into 3-byte binary code and transmitted from the Low byte (L : bits 0 to 7).

(Example)

Registered keyword	Conversion value to BIN code	Transmission order	Remarks
"012345"	01H, 23H, 45H	45H, 23H, 01H	Transmitted in order from 45H
"012300"	01H, 23H, 00H	00H, 23H, 01H	Transmitted in order from 00H

③ The character area keyword when a keyword is not registered in the specified drive is as follows.

- For ASCII code "000000"
- For binary code 00H, 00H, 00H

(b) Setting flag

This is the data that is used to show whether or not a keyword has been set in (a) for the keyword registered in the user specified drive.

① Data exchange using ASCII code

The following numerical value is converted into ASCII code 2 digits (hexadecimal) and transmitted from the first digit.

② Data exchange using binary code

The following 1-byte numerical value is transmitted.

③ The set flags specified contents are as follows.

Specified value	Specified contents
00H	Keyword is invalid (Specified as dummy)
01H	Keyword is valid (Specified as keyword registered in specified drive)

(c) Drive name

This data is used to read the drive memory usage state and perform optimization for the specified QnACPU drive.

① Data exchange using ASCII code

The following numerical value shown in access destination drive is converted to ASCII code 4 digits (hexadecimal) and transmitted from the first digit.

② Data exchange using binary code

The following 2-byte numerical value shown for the access destination drive is transmitted from the Low byte (L : bits 0 to 7).

③ The drive name specification contents are as follows, do not specify them to anything else.

Specified value	Target drive
0000H	Built-in RAM
0001H	RAM area of the memory card A
0002H	ROM area of the memory card A
0003H	RAM area of the memory card B
0004H	ROM area of the memory card B
000FH	Drive which stores the parameter file currently used (Set using the QnACPU's DIP switch)

(d) Cluster No.

This data is used to specify the head cluster No. of the drive memory usable state read range, and is specified in multiples of 16 (for hexadecimal 00H, 10H, 20H...).

① Data exchange using ASCII code

Converts other than the cluster No. 00H to ASCII code 4 digits (hexadecimal) and transmits from the first digit.

② Data exchange using binary code

The 2-byte numerical value shown other than cluster No. 00H is transmitted from the Low byte (L : bits 0 to 7).

③ Specifying the cluster No. is not required when the drive memory is optimized.

(e) Number of reads

This data specifies the number of clusters within the read range for the drive memory's usage state and is specified in multiples of 16 (for hexadecimal: 10H, 20H...).

① Data exchange using ASCII code

Convert the number of clusters 10H to 100H (16 to 256) to ASCII code 4 digits and transmit the first digit.

② Data exchange using binary code

Transmit the 2-byte numerical value that shows the number of clusters 10H to 100H (16 to 256) from the Low byte (L: bits 0 to 7).

③ Specifying the number of reads is not necessary when optimizing the drive memory.

Point

Specify the number of reads using the usable memory capacity after the drive format to be used in the usage state.

Number of clusters = usable memory capacity ÷ 1 cluster number of bytes (4096 or 512)

Refer to Item 10.5.

(f) List of vacant clusters

This is the data returned (shows the cluster use state) to the other node when the drive memory usage state is read.

① Data exchange using ASCII code

The following numerical values that shows the usage state are converted to ASCII code n digits (hexadecimal) and then transmitted to the other node. (16 cluster/4 digits)

② Data exchange using binary code

Transmits the m byte numerical value that shows the usage state to the other node. (16 cluster/2 bytes)

③ The contents of the vacant cluster list is as follows.

The usage state of each cluster is shown as 1 cluster/1 bit.

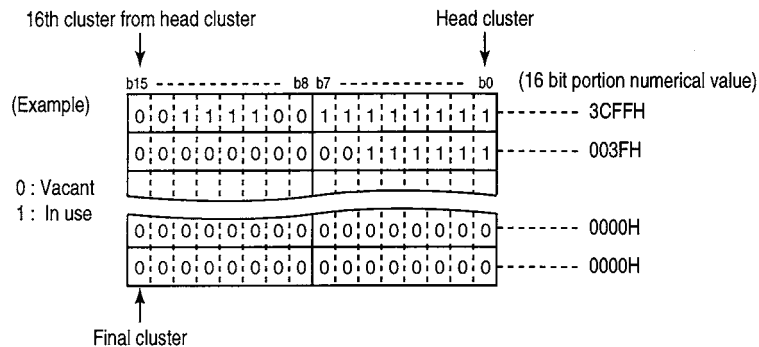

The contents of the vacant cluster list to be returned to the other node during the usage state shown in the figure above is as follows.

* When the 32 cluster portion is returned using ASCII code data exchange

“3CFF003F” is returned and transmitted in order from “3.”

* When the 32 cluster portion is returned using binary code

FFH, 3CH, 3FH, and 00H is returned and transmitted order from FFH.

④ The empty cluster list is not returned when the drive memory is optimized.

10.5.2 Drive Memory Usage State Read (Command : 0205)

This section uses an example to explain the drive memory usage state's read control procedure.

(Control procedure)

1 When the memory card A's RAM area (Drive name : 01H) drive memory usage state is read in 32-cluster portion during exchange using ASCII code

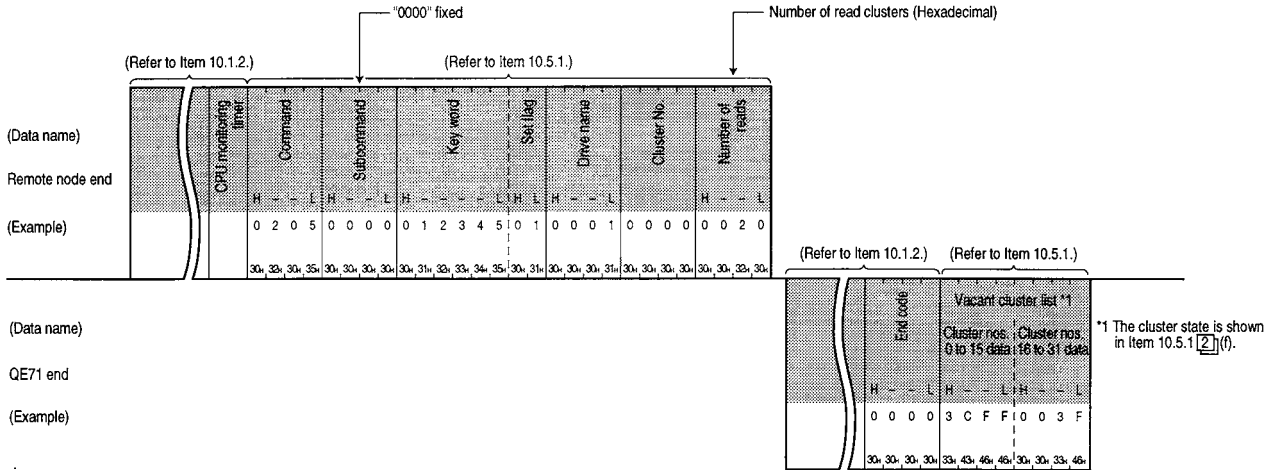

2 When the memory card A's RAM area (Drive name : 01H) drive memory usage state is read in 32-cluster portion during exchange using binary code

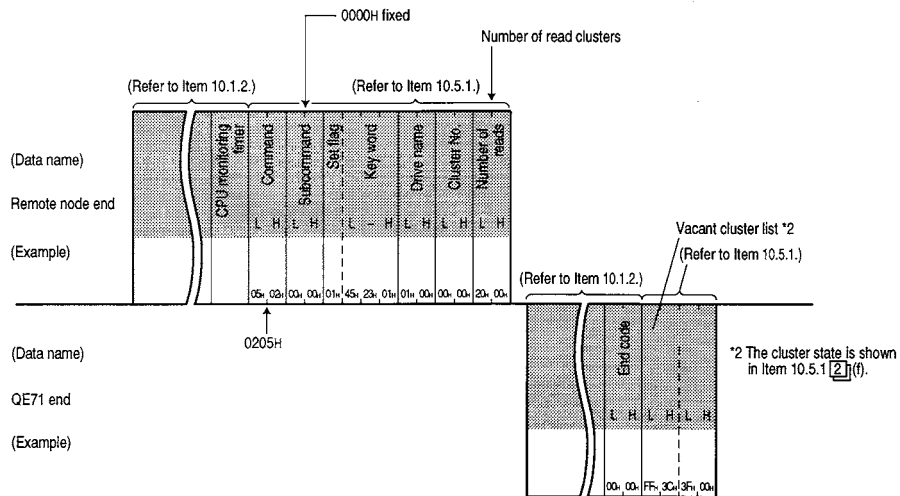

Point

- (1) Specify the number of reads to be within the range of 10H to 100H (16 to 256) in multiples of 16 (for hexadecimal : 10H, 20H...).
- (2) When creating new files (new registrations), a continuously vacant area of the size of the file being created is required. When the continuous vacant area capacity (size) is sought in a specified drive, the number of continuously vacant clusters (the number of off bits in a row) is checked by this drive memory's usage state read.
The continuous vacant area capacity (size) = continuously vacant number of clusters × 4096 or 512 (byte), and if the continuously vacant area is insufficient, perform the memory optimization shown in Item 10.5.3.

10.5.3 Drive Memory Optimization (Command : 1207)

This section uses an example to explain the drive memory optimization control procedure.

(Control procedure)

1 Memory card A's RAM area (Drive name : 01H) drive memory optimization when exchanging using ASCII code

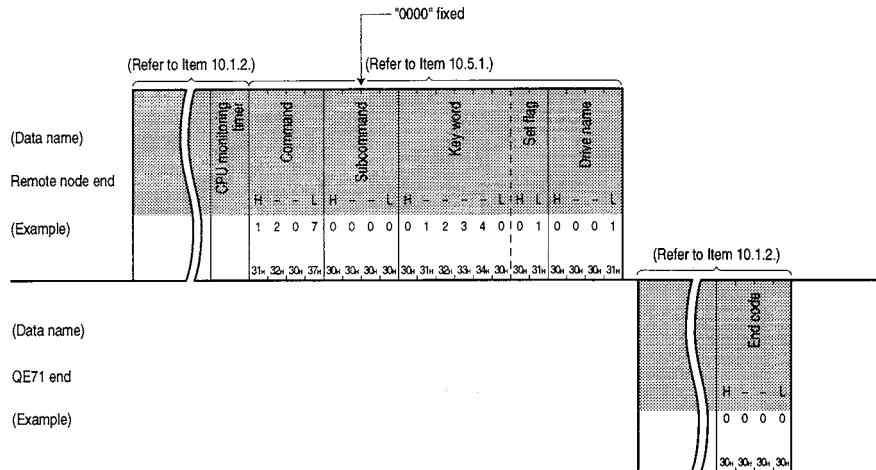

2 Memory card A's RAM area (Drive name : 01H) drive memory optimization when exchanging using binary code

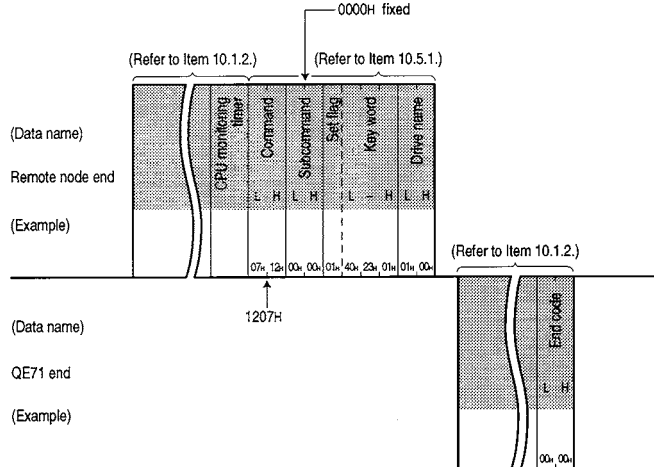

Point

- (1) Conduct drive memory optimization as follows.
 - When the specified station QnACPU is in the STOP state.
 - When the drive memory usage state (Check using command 0205) is scattered around the drive and the file cannot be stored.
- (2) This will cause an error and an end code will be returned at the time of error.
 - ① When a system protect (system protect switch SW5 is on) is applied to the QnACPU.
 - ② When only the keyword registered in the specified drive is specified.
 - ③ There is an error in the drive memory. (There is a defective cluster, etc.)
 - ④ When the following is conducted using an IC memory card reader/writer.
 - When a subdirectory is created.
 - When one file is not stored in one location of a continuous area.

10.6 File Control

This function is used to perform file registration state read, new registration, and data read, and write and delete for the QnACPU's specified drive.

This function can be used by being read from the QnACPU and stored by several of the remote node's typed parameters and sequence programs, etc., and written to the QnACPU in the parameters and sequence programs from the remote node in response to the control contents.

10.6.1 Command and Character Area Contents

This section explains the character portion of the commands and control procedure when file control is conducted.

1 Command

Functions		Command (Subcommand) * For ASCII code: Specify each ASCII code. For binary code: Specify each num- eral as hexadeci- mal numeral.	Description of processing	Number of points pro- cessed per 1 exchange		PLC CPU state			Reference Item	
				Access station-1 (Refer to Item 9.2.1 ⁷⁾)	Access station-2 (Refer to Item 9.2.1 ⁸⁾)	During STOP	During RUN			
							Write pos- sible setting	Write not pos- sible setting		
File informa- tion list read	No titles	0 2 0 1 (0 0 0 0)	Reads the file list (file name, last date of editing, file size).	(36 units)	(Not possible)				Item 10.6.4 1	
	With title	0 2 0 2 (0 0 0 0)	Reads a file list of files with titles.	(16 units)		○	○	○	Item 10.6.4 2	
	File No. usage state	0 2 0 4 (0 0 0 0)	Reads the file No. usage state.	(256 units)					Item 10.6.4 3	
File informa- tion change	Final edit- ing date change	1 2 0 4 (0 0 0 0)	Changes the final editing change date.	(1 units)					Item 10.6.5 1	
	File name and size change	1 2 0 4 (0 0 0 1)	Changes the file name and file size.			○	○	×	Item 10.6.5 2	
	Batch change	1 2 0 4 (0 0 0 2)	Changes the file name, file size, and last editing date.						Item 10.6.5 3	
File search (File exist- ence)		0 2 0 3 (0 0 0 0)	Reads the specified file's file No. and file size.	(1 units)			○	○	○	Item 10.6.6
File contents read (Batch read)		0 2 0 6 (0 0 0 0)	Reads the file contents.	960 bytes			○	○	○	Item 10.6.7
New registration (File name registration)		1 2 0 2 (0 0 0 0)	Checks the specified file name area.	(1 units)			○	○	×	Item 10.6.8
File contents write	Voluntary data (Batch write)	1 2 0 3 (0 0 0 0)	Writes the specified data (n-byte portion) to the file.	960 bytes			○	○	×	Item 10.6.9 1
	Same data (FILL)	1 2 0 3 (0 0 0 1)	Writes the specified data (1 word) n-byte portion to the file.	(File size portion)						Item 10.6.9 2
File lock	Registra- tion	0 8 0 8 (0 0 0 1)	Registers a file lock to prevent the contents from being changed by another module. Or cancels registration.	(1 units)			○	○	○	Item 10.6.10
	Cancel	0 8 0 8 (0 0 0 0)								
File copy		1 2 0 6 (0 0 0 0)	Writes the contents of an existing file to a newly registered file.	480 bytes		○	○	○	Item 10.6.11	
File delete		1 2 0 5 (0 0 0 0)	Deletes the file.	(1 units)		○	○	×	Item 10.6.12	

○ in the PLC CPU state column of the above table shows that execution is possible.

2 Character area contents

This section explains about the message character area contents after Item 10.6.4 when the remote node conducts QnACPU file control.

(a) Keyword

This data is used as the character string (6 characters) that is registered in the specified drive by the user and to determine whether access to the drive is enable/disable.

When a key word is registered, specify the same key word.

Refer to Item 10.5.1 [2](#) (a) for information regarding the character area contents.

(b) Set flag

This data shows whether the key word described in (a) is specified as the key word registered in the specified drive by the user.

Refer to Item 10.5.1 [2](#) (b) for information regarding the character area contents.

(c) Drive name

This data is used to specify the QnACPU drive that performs file control. Refer to Item 10.5.1 [1](#) (c) for information regarding the character area contents.

(d) File No.

This data is used to specify the registration No. when the following file name and extension are registered (written) to the PLC CPU that specifies the file, and to specify the registration No. as registered to the PLC CPU.

① Data exchange using ASCII code

The following file No. is converted to ASCII code 4 digits (hexadecimal) and transmitted.

(Example) For 1FH..... Becomes "001F" and is transmitted in order from "0."

② Data exchange using binary code

The 2 byte shown in the file No. below is transmitted from the Low byte (L : bits 0 to 7).

(Example) For 1FH..... Becomes 001F and is transmitted in order from 1FH, 00H

③ The file No. is specified by one of the following.

Specified value	Contents	Description of specification
01H to 100H	File No.	Specified when the file No. is known.
FFFFH	File No. Unknown	Specified when the file No. is searched in the QE71. (The read and write request to the PLC CPU from the QE71 will be delayed by more than one PLC scan time.)

④ The registered files file No. can be checked using the file existence read function described in Item 10.6.6.

When registering a new file, the unused file No. can be checked using the file No. usage state read function described in Item 10.6.4

- (e) Number of file requests, number of all registration files, number of file information

This data is used to show the number of files requested by the user, the number of files registered in a specified drive, and the number files returned by the file information when the file information is read.

- ① Data exchange using ASCII code

Each of the numerical values shown in this function explanation item are converted to ASCII code 4 digits (hexadecimal) and transmitted from the first digit.

- ② Data exchange using binary code

The 2 byte numerical values shown in this function explanation item are each transmitted from the Low byte (L : bits 0 to 7).

- (f) File name, extension, attributes

This data is used to specify the file for which read/write/and registration will be conducted.

When an existing file is specified, specify the file name, extension, and attribute that are registered (written) in the PLC CPU by the file.

When specifying a newly registered file or changing a name, specify the file name (maximum of 8 characters (when half width)) extension (maximum 3 characters (when half width)) following the file naming rules when using the GPP function for the QnACPU.

* Half width characters for alpha numeric characters, symbols, KANA characters, and full width characters (shift JIS Kanji code) can be used.

For detail refer to the GPP function's operating manual (on-line edition).

The user created file attribute is initially 20H (disk file), and the user can change this attribute. (Refer to Item 10.6.5)

- ① Data exchange using ASCII code

Transmission is conducted from each of the first characters.

The newly created file attributes and attribute when dummy is specified are transmitted as blank (code : 20H).

When the file name is less than 8 characters long, a blank (code : 20H) is added.

(Example) When the file name at registration is "ABCD12"

Becomes "ABCD12 " and is transmitted in order from the "A."

- ② Data exchange using binary code

The file name and extension are transmitted from the first character as binary values for each character's character code.

The newly created file attribute and attribute when dummy is specified are transmitted as 1 byte numerical values [20H].

When the file name is less than 8 characters long, 20H is added until 8 characters in length is reached.

(Example) When the file name at registration is "ABCD12"

The file name becomes 41H, 42H, 43H, 44H, 31H, 32H, 20H, 20H and is transmitted in order from 41H.

- ③ The attribute of an existing file can be checked using the file existence read function described in Item 10.6.6.

Remarks

Following is a summary of how to view the file attributes stored in each of the QnACPU's disks. Each of the bits in the numerical value shown for the attribute has a meaning. When a particular bit is on **1** it has a corresponding attribute.

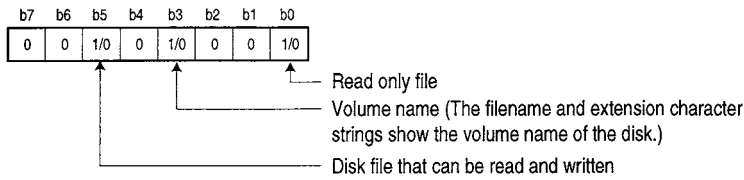

* User created files for which the attributes do not change are given read/write possible disk file attributes.

The user created file attributes can be changed between 01H (read only file) and 20H (read/write possible disk file). (Refer to Item 10.6.5)

(g) Final editing time and final editing date

This data shows the time and date of the registration of the current contents.

① Data exchange using ASCII code

Each of the following numerical values are converted into ASCII 4 digit (hexadecimal) and transmitted from the first digit (time, year).

When a dummy is specified "0000" is transmitted.

② Data exchange using binary code

Each of the following 2 byte numerical values is used and transmission is conducted from the Low byte (L : bits 0 to 7).

When dummy is specified, 0000H is transmitted.

③ The contents and transmission order of the numerical values shown in the time and date are as follows.

- Time (hour, minute, second)

(Example) For 20th hour, 50th minute, 58th second

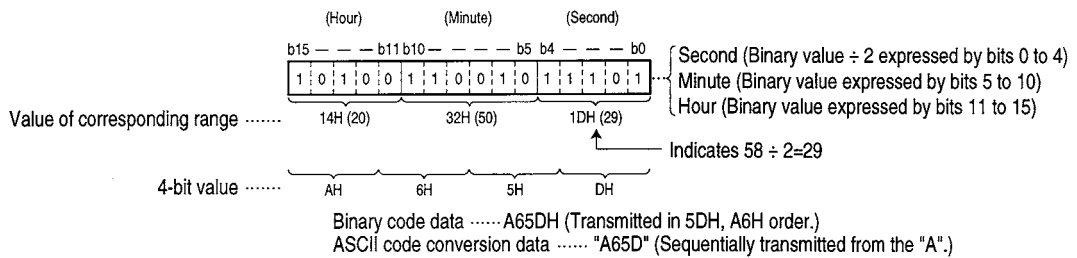

- Date (Year, Month, Day)

(Example) For January 8th, 1996

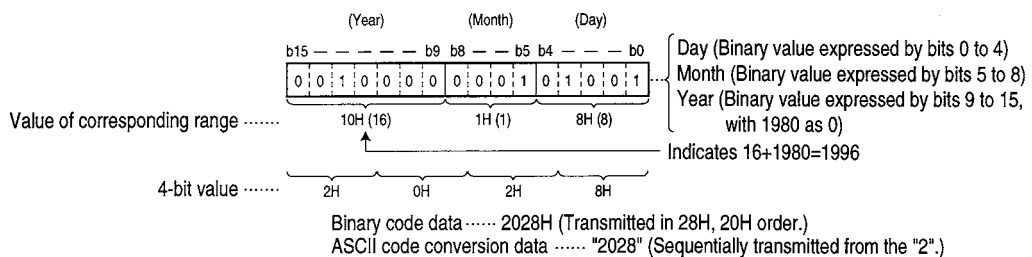

(h) File size

This data shows the number of bytes in an existing file size.

① Data exchange using ASCII code

The 2 word numerical value is converted to ASCII code 8 digits (hexadecimal) and transmitted.

(Example) For a file size of 7168 bytes

Becomes "00001C00" and transmission is done in the order from the first digit "0."

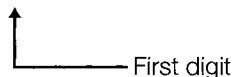

② Data exchange using binary code

The 2 word numerical value is transmitted from Low byte (L : bits 0 to 7).

(Example) For a file size of 7168 bytes

Becomes 00001C00H and is transmitted in order from 00H, 1CH, 00H, 00H.

(i) Title text

This is the title text added to the specified file by the GPP function for the QnACPU. (Maximum 32 characters (for half width characters))

① Data exchange using ASCII code

Transmission is conducted from the first digit of each title.

When a title is less than 32 characters long, blanks (code : 20H) are added.

(Example) For a title of "1line-PLC5" at the time of registration

Becomes "1line-PLC5..." and transmission is begun in order from the "1."

② Data exchange using binary code

Binary values are used for the character codes of each character in the title, and are transmitted in order from the first character.

When the title is less than 32 characters long, 20H is added until 32 characters is reached.

(Example) When the title at registration is "1line-PLC5"

Becomes 31H, D7H, B2H, DDH, 2DH, 50H, 43H, 35H, 20H, 20H, and transmission is done in order from 31H.

(j) Offset address

This data is used to specify the head address range for reading and writing data for a file. Specifies the address (1 address/1 byte) from each file's head (offset address : 0H) using even addresses.

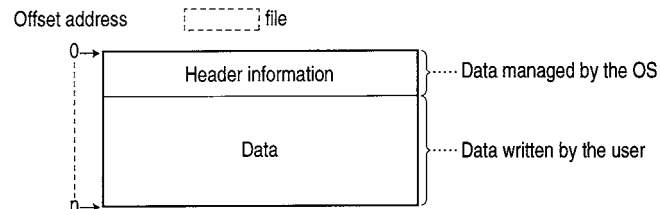

① Data exchange using ASCII code

The addresses shown in this function explanation are converted to ASCII code 8 digits (hexadecimal) and transmitted from the first digit.

② Data exchange using binary code

The 4 byte numerical values shown as addresses in this function explanation are transmitted from the Low byte (L : bits 0 to 7).

③ The file size (number of bytes) of specifiable offset addresses can be checked using the file information list read function described in Item 10.6.4, so find the offset address (0H to nH) from this size.

(k) Number of read bytes and number of write bytes

This data is used to specify the number of bytes in the data's read/write range for the file and is specified as 1 address/1 byte.

① Data exchange using ASCII code

The numerical values shown in this function explanation are converted to ASCII code 4 digits (hexadecimal) and transmitted from the first digit.

② Data exchange using binary code

The 2 bit numerical values used in this function explanation are transmitted from Low byte (L : bits 0 to 7).

(l) Read data and write data (For batch read and batch write)

This is the read data from the QnACPU file and the write data from the QnACPU file and is ordered from the offset address.

① Data exchange using ASCII code

The 1 byte (1 address) portion is converted to ASCII code 2 digits (hexadecimal) and this data is transmitted from the first digit of the specified number of bytes portion.

② Data exchange using binary code

The specified number of bytes is transmitted as 1 byte per 1 address.

③ During read the order read from the QnACPU is preserved as is in the remote node.

During write, the order of the read from the QnACPU is specified as is.

(m) Write data (For same data write function)

This data is used for the same data write function that writes the same data to existing QnACPU files.

① Data exchange using ASCII code

The 1 word numerical value is converted to ASCII code 4 digits (hexadecimal) and transmitted from the first digit.

② Data exchange using binary code

The 1 word numerical value is transmitted from Low byte (L : bits 0 to 7).

(n) Size

This data is for storing on the specified disk the file area when a file is newly registered and specifies the number of bytes.

① Data exchange using ASCII code

The numerical values that express the 2 words used for the specified file area being saved are converted to ASCII code 8 digits (hexadecimal) and transmitted from the first digit.

② Data exchange using binary code

The numerical values that express the 2 words of the specified file area to be saved are transmitted from the Low byte (L : bits 0 to 7).

③ The same contents as in an existing file can be registered in a new file from a remote node.

The size of the subject existing file must be checked using the file information list read described in Item 10.6.4.

(o) Fixed value

① Transmitted as "0000" when data is exchanged using ASCII code.

② Transmitted as the 2 byte numerical value [0000H] when data is exchanged using binary code.

(p) Change pattern (For changing the file name and file size)

This data is used to specify which information will be changed when existing file information (file name, size, creation date, time) is changed.

① When exchanging data using ASCII code

The following numerical values are converted to ASCII code 4 digits (hexadecimal) and transmitted from the first digit.

② When exchanging data using binary code

The following 2 byte numerical values are transmitted from the Low byte (L : bits 0 to 7).

③ The change pattern specified values and contents are as follows.

- For file creation date and time change (command : 1204, subcommand : 0000)

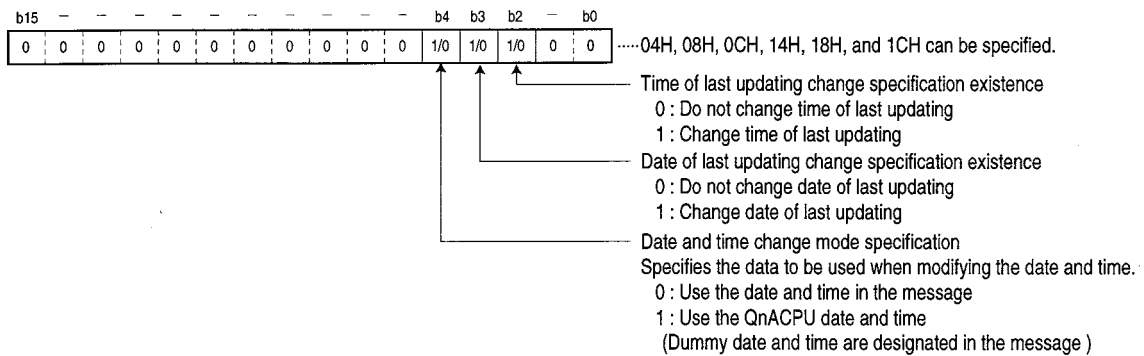

- When the file name and file size are changed.

(Command : 1204, subcommand : 0001)

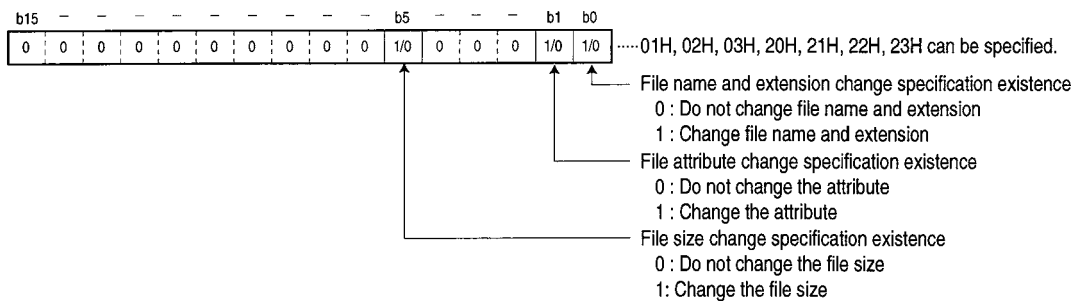

- For file information batch change (command : 1204, subcommand : 0002)

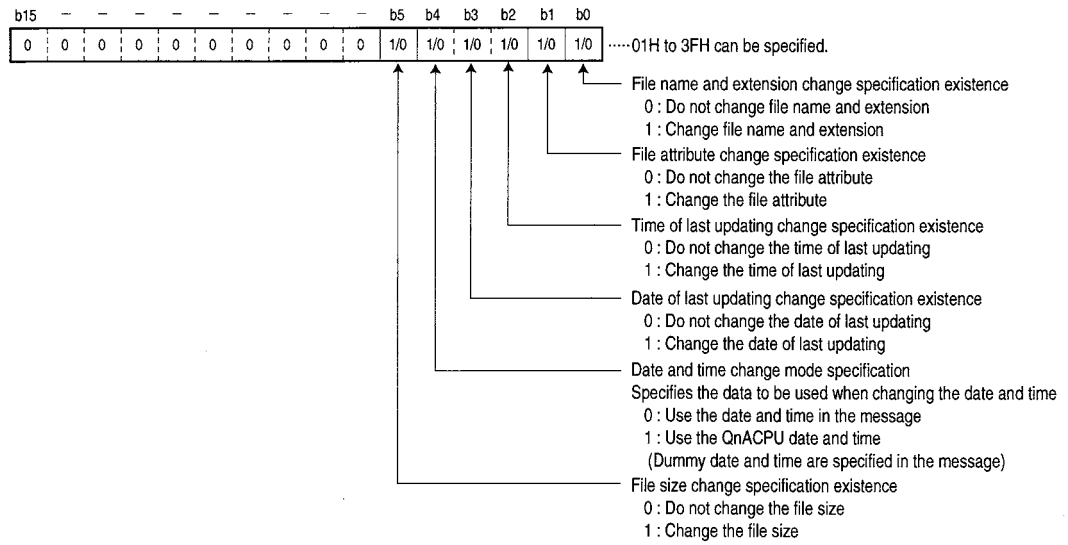

(q) File No. usage state

This data shows the 256 unit file No. usage state return to the remote node by the file No. usage state read, and is ordered from the first byte shown in the following file No. usage state diagram.

① Data exchange using ASCII code

The following numerical values are converted to ASCII code 64 digits (hexadecimal) and return to the remote node. (8 unit file No. : 2 digits)

② Data exchange using binary code

The 32 bytes numerical value shown in the usage state below is returned to the remote node from the Low byte (L : bits 0 to 7). (The 8 unit file No. : 1 byte)

③ The file No. usage state contents are as follows.

The usage state for all files No. is 1 file No./1 bit.

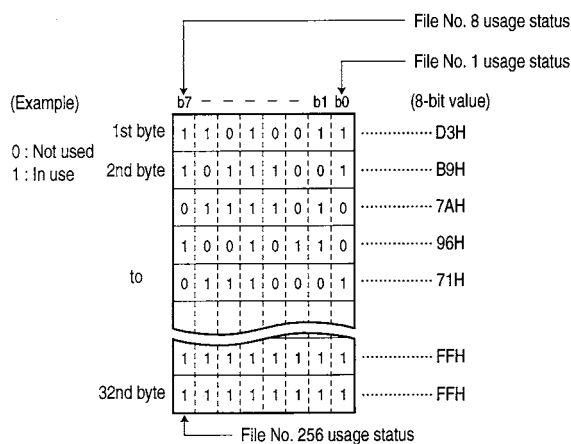

The file No. usage state contents that are returned to the remote node for the above shown usage state are as follows.

- For data exchange using ASCII code, "D3B97A...FFFF" is returned and is returned in the order from "D."
- For data exchange using binary code, D3H, B9H, 7AH...FFH, FHH are returned, and returned in the order from D3H.

(r) File lock mode

This data is used to specify whether forceful execution to release a file lock that approves access to the specified file from other equipment, etc.

① Data exchange using ASCII code

The following numerical values are converted to ASCII code 4 digits (hexadecimal) and transmitted from the first digit.

② Data exchange using binary code

The 2 byte numerical values shown below are transmitted from the Low byte (L : bits 0 to 7).

③ The file lock mode specified values and specified contents are as follows, and other than these cannot be specified.

Specified value	Description of specification
0000H	Normal execution of file lock release.
0002H	Forced execution of file lock release.

④ The difference between normal execution and forced execution of file lock release for a specified file are shown below.

• Normal execution

The file lock is not released when file lock registration is conducted from other equipment. A release request will cause an error and an end code at the time of error will be returned.

• Forced execution

Forcefully releases the file lock when a file lock registration is conducted from other equipment. The forceful execution function is used when the file lock cannot be released because of trouble occurring at the equipment that registered the file lock.

(s) Copy mode

This data is used to specify whether the copy origin file final edition date and time is copied to the destination file when copy is completed when a file copy is conducted. When a copy is not conducted, the new file creation time remains as the QnACPU's control time.

① Data exchange using ASCII code

The following numerical values are converted to ASCII code 4 digits (hexadecimal) and transmitted from the first digit.

② Data exchange using binary code

The 2 byte numerical values shown below are transmitted from the Low byte (L : bits 0 to 7).

③ The copy mode specified values and contents are as follows.

Specified value	Description of specification
0000H	The copy origin file's final edition date and time is not copied when copy is completed.
0001H	The copy origin file's final edition date and time is copied when copy is completed.

10.6.2 Precautions When Using File Control

This section shows the precautions to take when conducting QnACPU file control using the functions described in Item 10.6.

1 Files read from the QnACPU are stored in the remote node.

The contents of files read from the QnACPU cannot be edited (corrected, changed) at the remote node end.

2 The maximum number of bytes of data that can be read or written is set.

For each file, read all the data by dividing it into several segments when reading data to the remote node or writing data to the QnACPU. When writing from the remote node, write it by dividing the read data into several segments.

The file size can be checked using the following functions.

- File information list read function Refer to Item 10.6.4
- File existence read function Refer to Item 10.6.6

3 When the following functions are used when a system protect is applied to the QnACPU (system protect switch SW5 is on) an error will occur and an end code will be returned at the time of error.

- File information change function Refer to Item 10.6.5
- File new registration function Refer to Item 10.6.8
- File contents write function Refer to Item 10.6.9
- File copy function Refer to Item 10.6.11
- File delete function Refer to Item 10.6.12

4 Remember the key word when a key word is registered in the disk that is subject to file control.

Be sure to specify the registered key word when accessing the following files.

- Parameter file
- Program file
- Data write file (when the command : 1203 and subcommand : 0001 are specified)

5 The file attribute data is only valid when the following functions are used.

The file attribute data is handled by functions other than the following.

- File information read function Refer to Item 10.6.4
- File information change function Refer to Item 10.6.5
- File new registration function Refer to Item 10.6.8

6 For precautions in addition to those given above, please refer to the explanation items points for each function.

10.6.3 File Control Execution Procedure

The procedure for conducting file control is shown in the following flow.

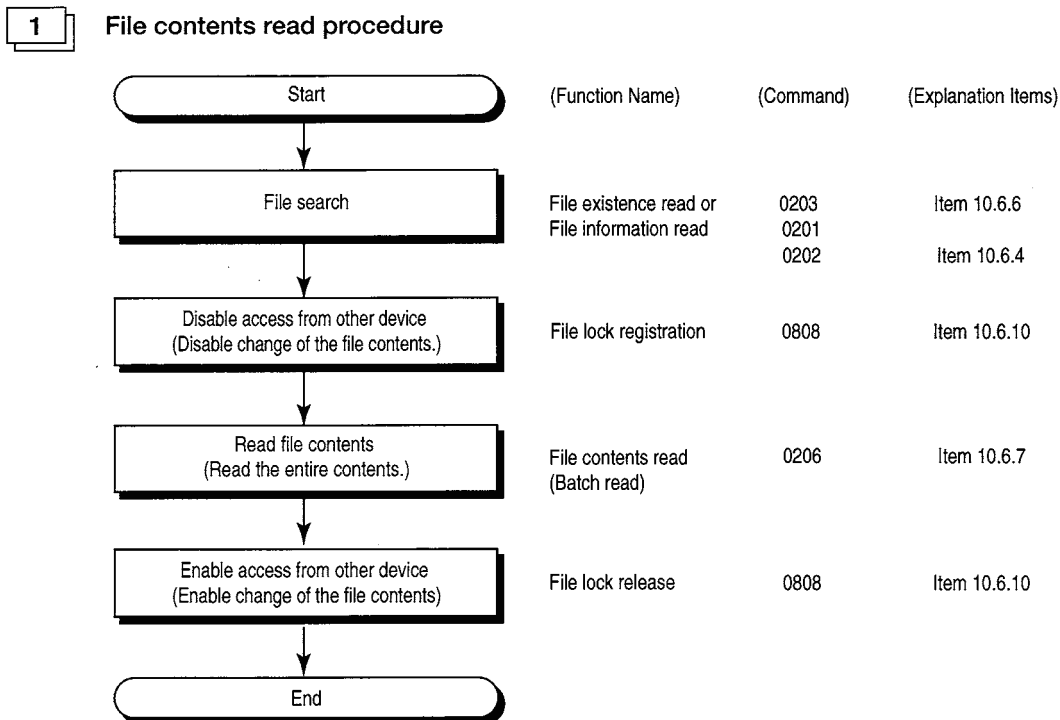

Point

Store in memory the following file information for files read (for save) by a remote node.

- File No.
- File name and attributes
- File size

2 File new creation and data write procedure

Procedure for copying existing file data to a newly created file

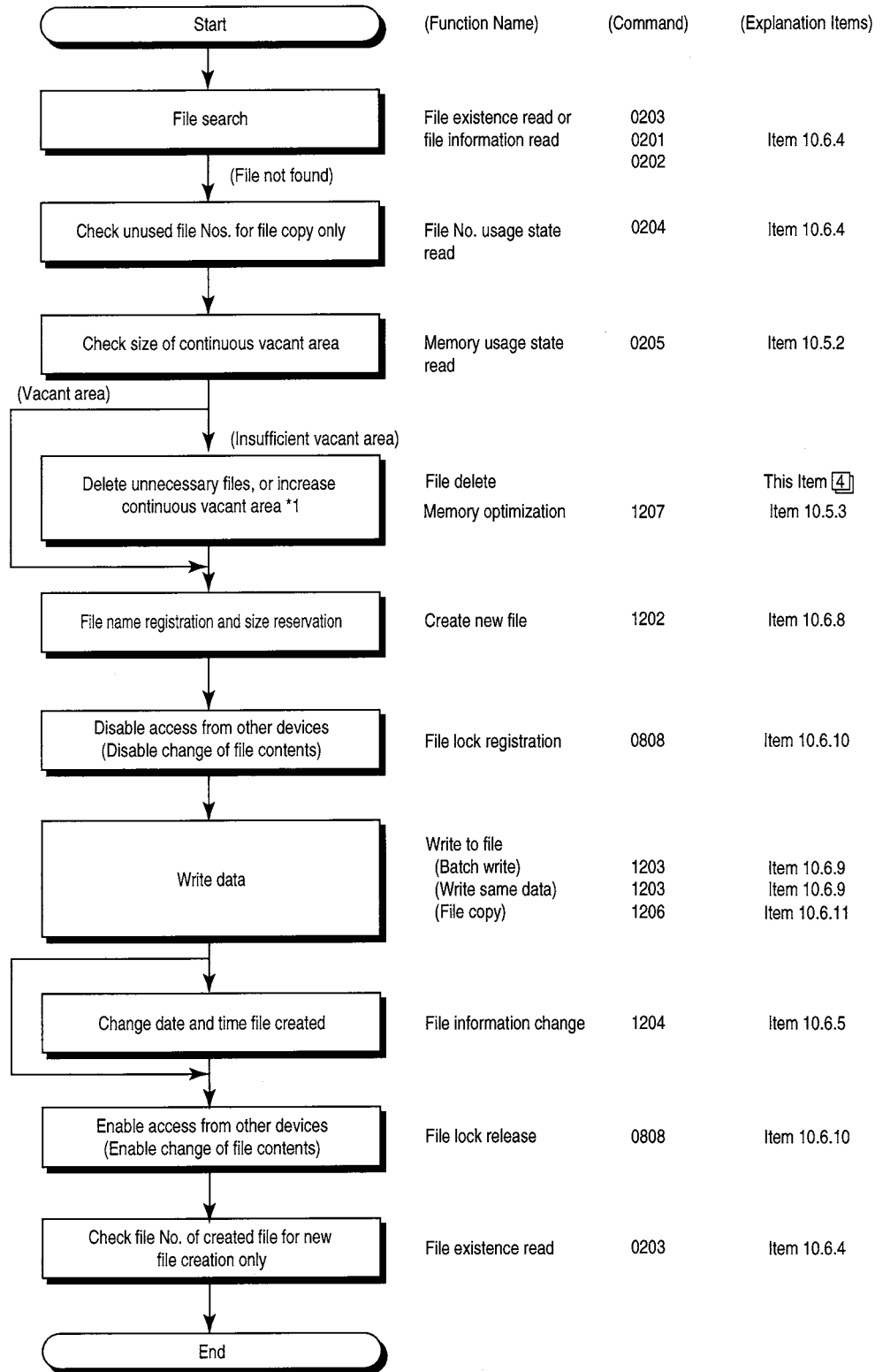

*1 Optimize the memory after putting the QnACPU in the STOP state using the remote STOP (command : 1002) function, etc. described in Item 10.4.3.

After the processing in this item is completed, the QnACPU can be put in the RUN state using the remote RUN (command : 1001) functions, etc. described in Item 10.4.2.

3 Existing file data overwrite procedure
Procedure for changing file information

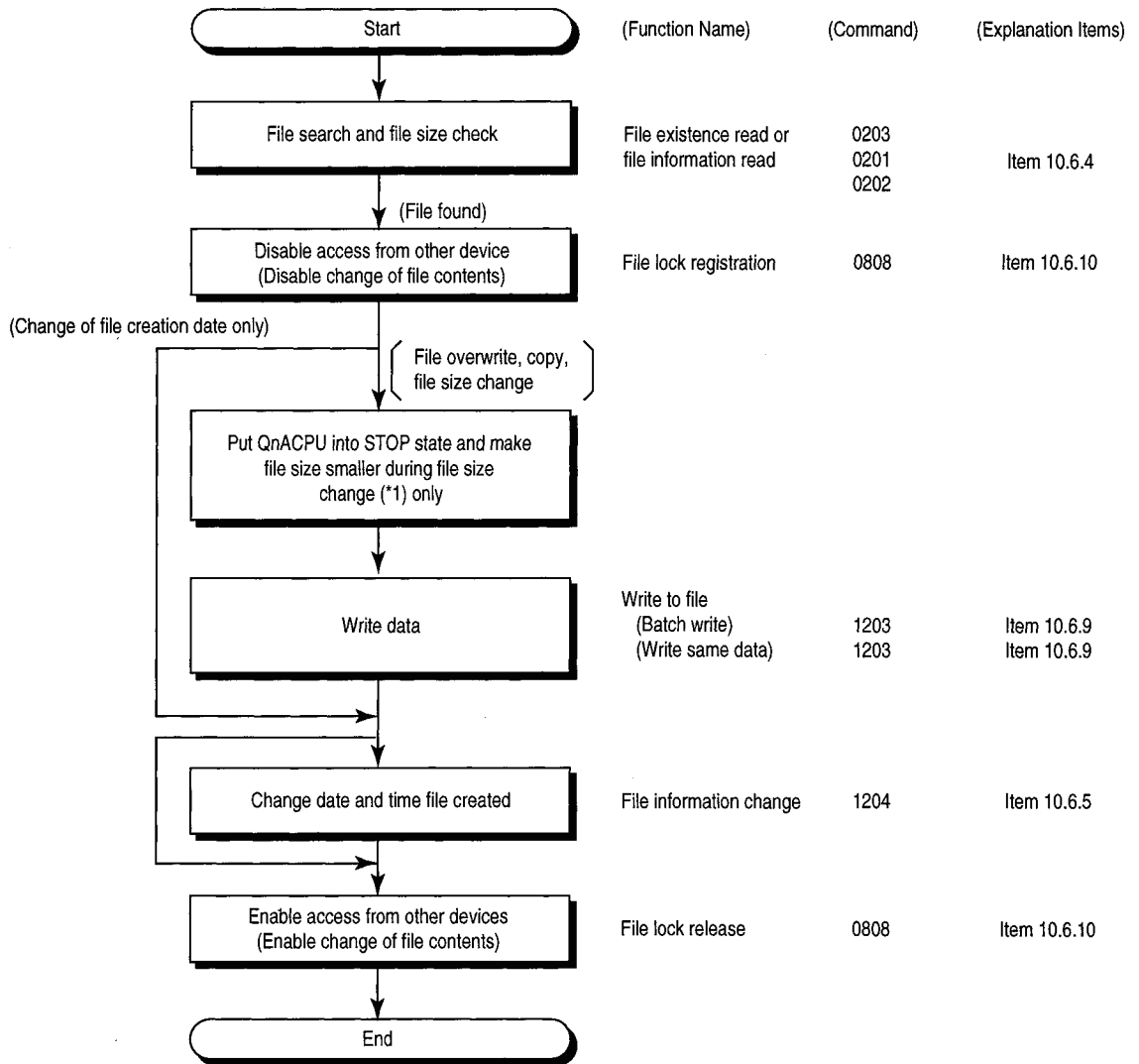

*1 The file information change (command : 1204) function described in Item 10.6.5 can only be used to change the file size to make the file size smaller. If the file size needs to be made bigger, create a new file and write the data following the procedure described in **2** of this item.

4 File delete procedure

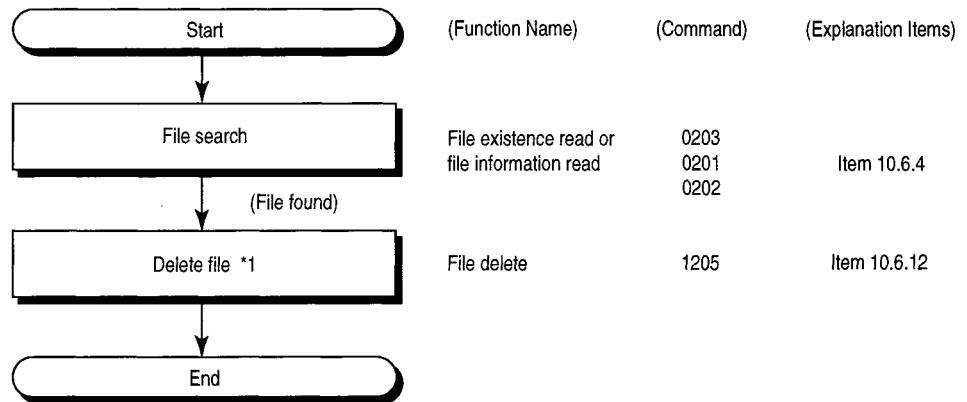

*1 Set the file deletion timing in arrangement with the entire system including the QnACPU and related equipment.

10.6.4 Reading the File Information List

1 Reading the file information list without titles (Command : 0201)

This section uses an example to explain the specified file No. range file information read control procedure.

(Control procedure)

(a) When reading 2 units of file information from the memory card A (RAM area, drive name : 01H) file No. 16 (10H) when exchanging using the ASCII code

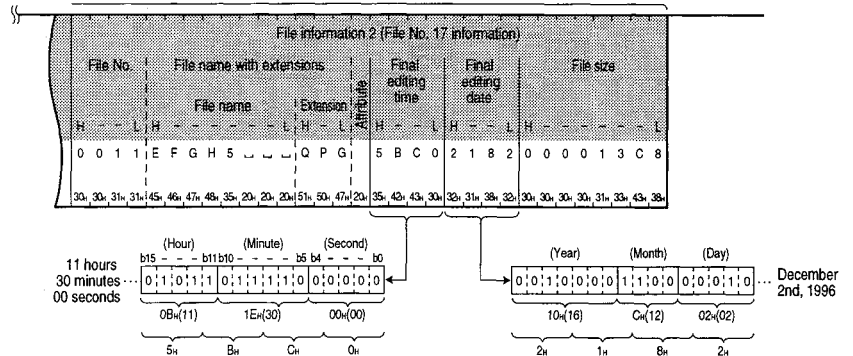
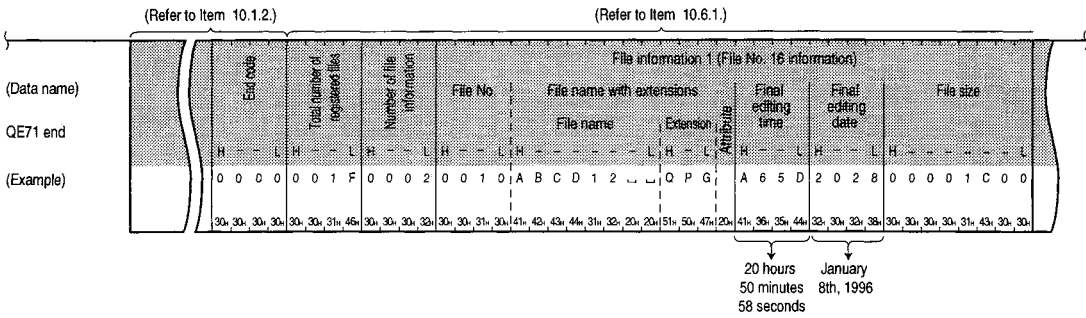
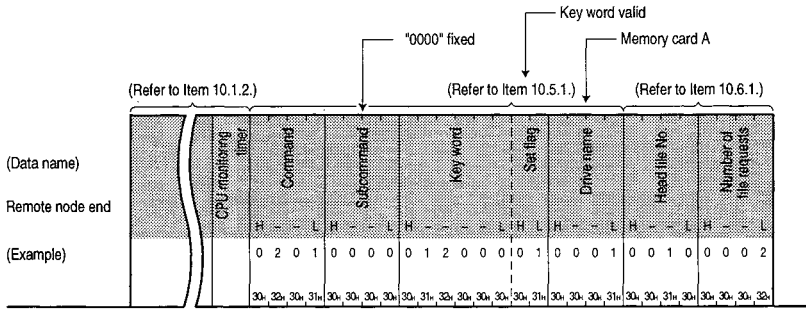

(b) When reading 2 units of file information from the memory card A (RAM area, drive name : 01H) file No. 16 (10H) when exchanging using the binary code

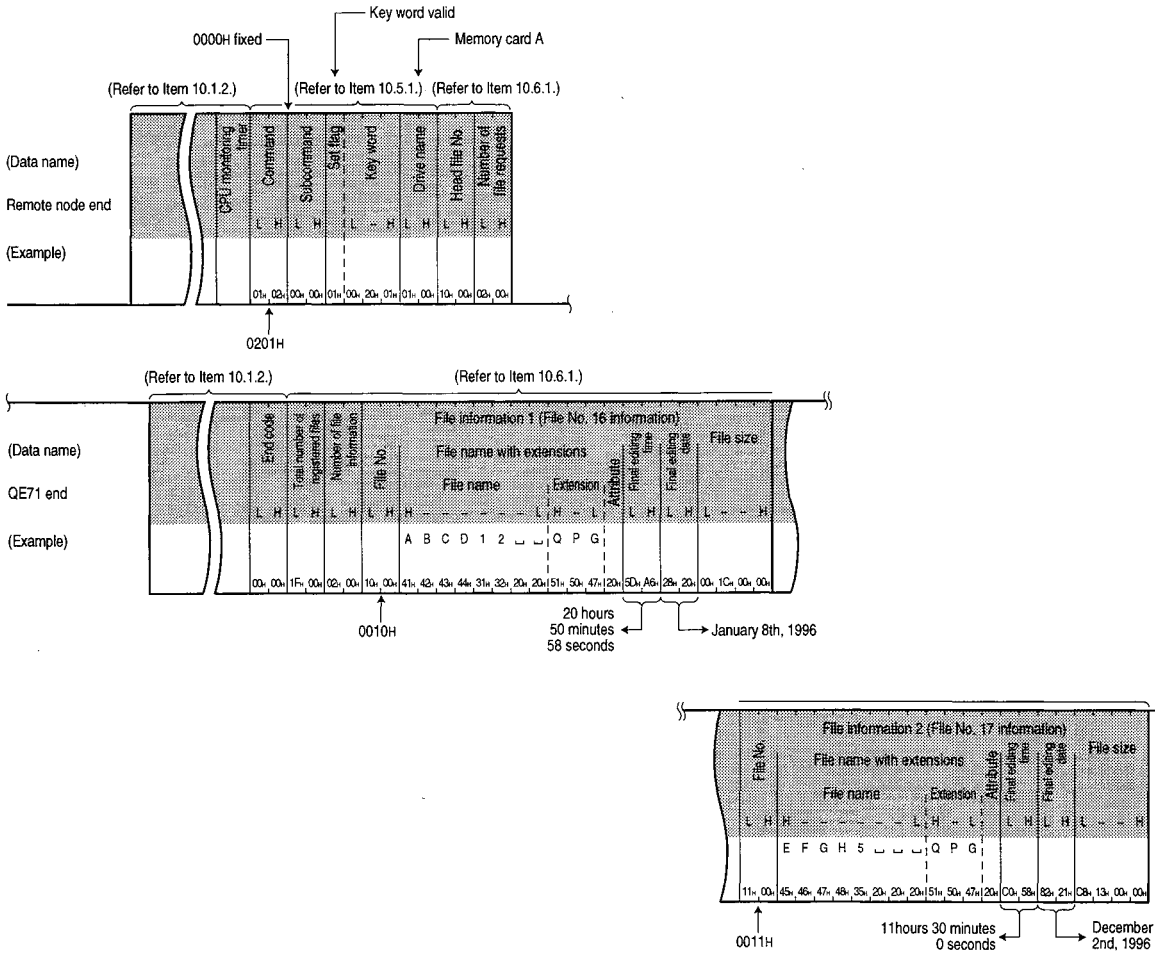

Point

- (1) Specify the specification values with the following range.
 - Head file No. 1 ≤ file No. ≤ 256
 - Number of file request 1 ≤ file No. ≤ 36
 - Total number of registered files 1 ≤ number of files ≤ 256
 - Number of file information 0 ≤ number of files ≤ number of file requests
(0 : no files registered after the specified head file No.)
- (2) The total number of registered files is the total number of files currently registered in a specified drive.
- (3) If all of the files are not registered within the specified file No. range, the number of file information will be the number of files registered in the specified range (number of file information to be returned).

2 Reading the file information list with titles (Command : 0202)

This section uses an example to explain the read control procedure for file information with titles in the specified file No. range.

(Control procedure)

- (a) When 2 units of file information are read from the memory card A (RAM area, drive name : 01H) file No. 16 (10H) using ASCII code

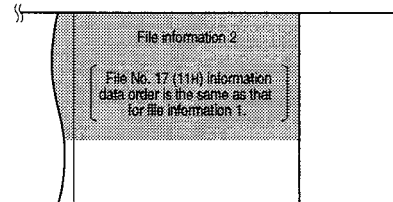
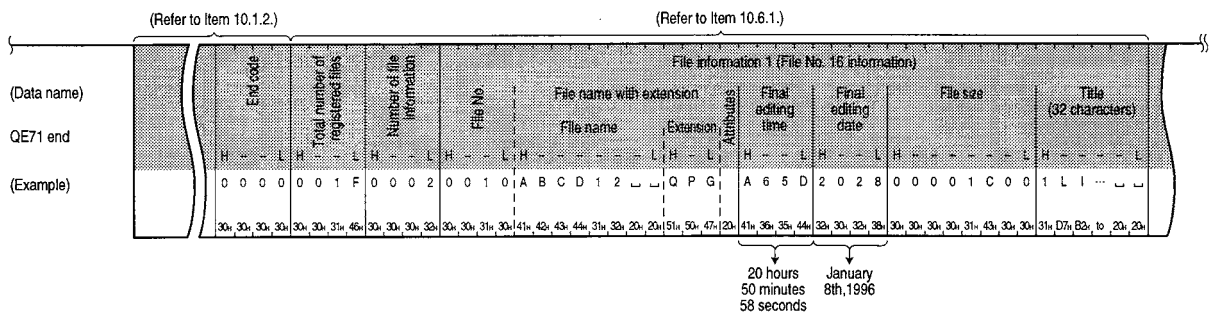
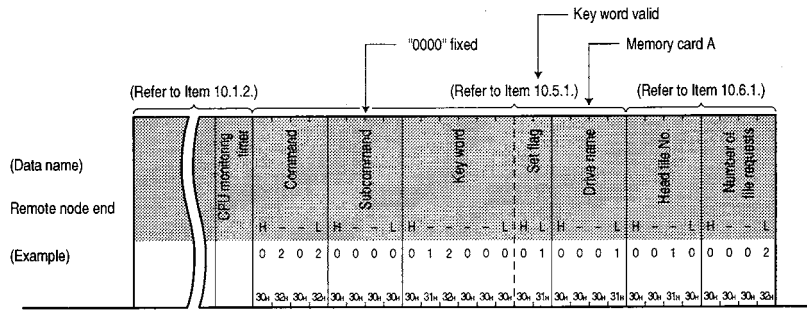

(b) When 2 units of file information are read from the memory card A (RAM area, drive name : 01H) file No. 16 (10H) using binary code

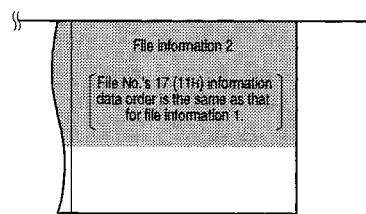
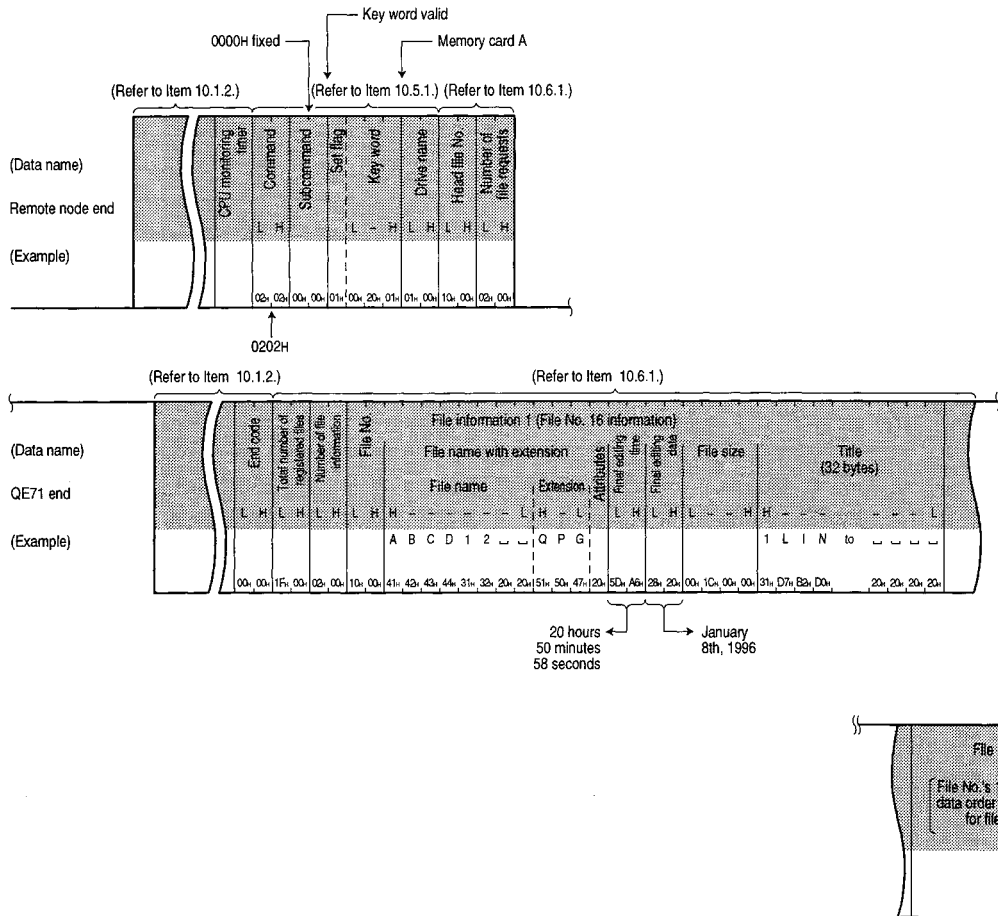

- Point**
- (1) Specify the specification values with the following range.
 - Head file No. 1 ≤ file No. ≤ 256
 - Number of file request 1 ≤ file No. ≤ 16
 - Total number of registered files 1 ≤ number of files ≤ 256
 - Number of file information 0 ≤ number of files ≤ number of file requests
(0 : no files registered after the specified head file No.)
 - (2) The total number of registered files is the total number of files currently registered in a specified drive.
 - (3) If all of the files are not registered within the specified file No. range, the number of file information will be the number of files registered in the specified range (number of file information to be returned).

3 Reading the file No. usage state (Command : 0204)

This section uses an example to explain the file No. usage state read control procedure.

(Control procedure)

- (a) When reading the memory card A (RAM area, drive name : 01H) file No. usage state when exchanging using ASCII code

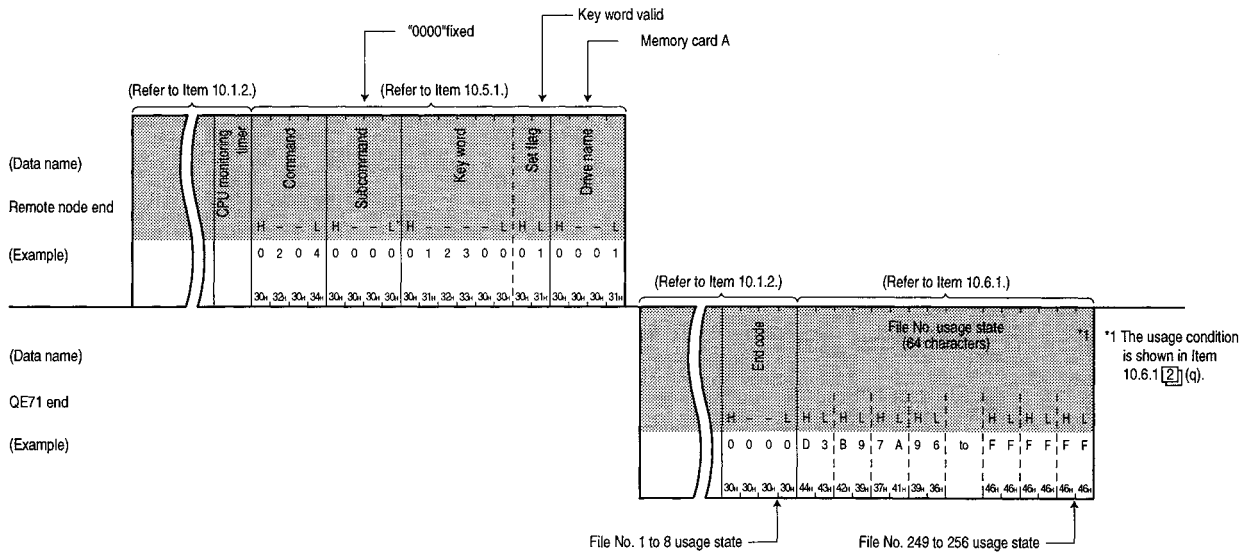

(b) When reading the memory card A (RAM area, drive name : 01H) file No. usage state when exchanging using binary code

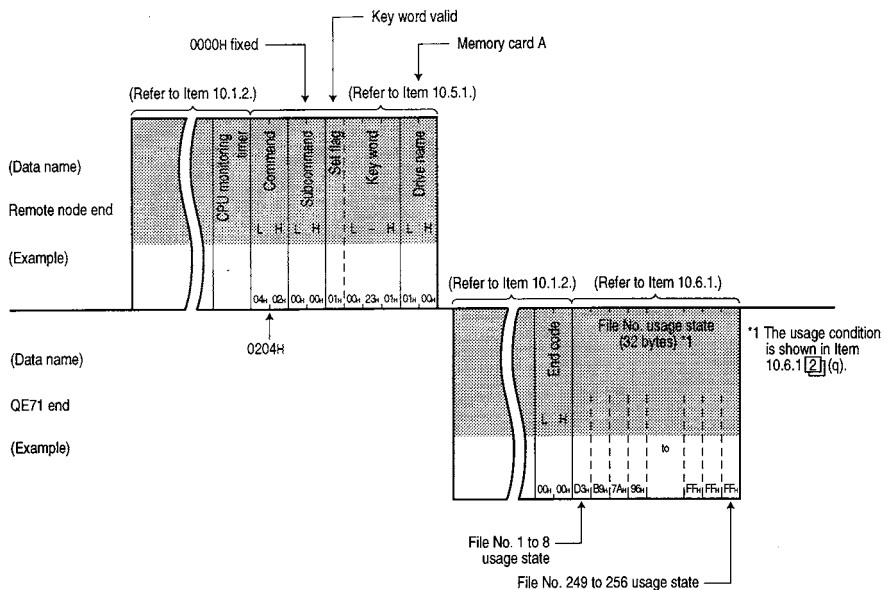

Point

When specifying a drive memory that cannot store a maximum of 256 files, the file No. that can not be stored in the file (insufficient portion) will become in use (corresponding bit will be 1).

10.6.5 Changing File Information (Command : 1204)

1 Changing the file creation date and time (Command : 1204, subcommand : 0000)

This section uses an example to explain the specified file's final editing date and time change control procedure.

(Control procedure)

- (a) When changing the memory card A (RAM area, drive name : 01H) file name "ABC12.QPG" final editing time when using ASCII code for exchange (The file No. is unknown and the final editing time is specified as the QnACPU time.)

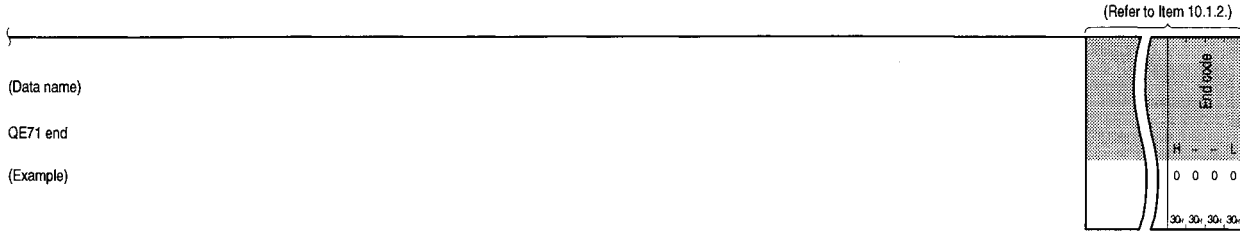
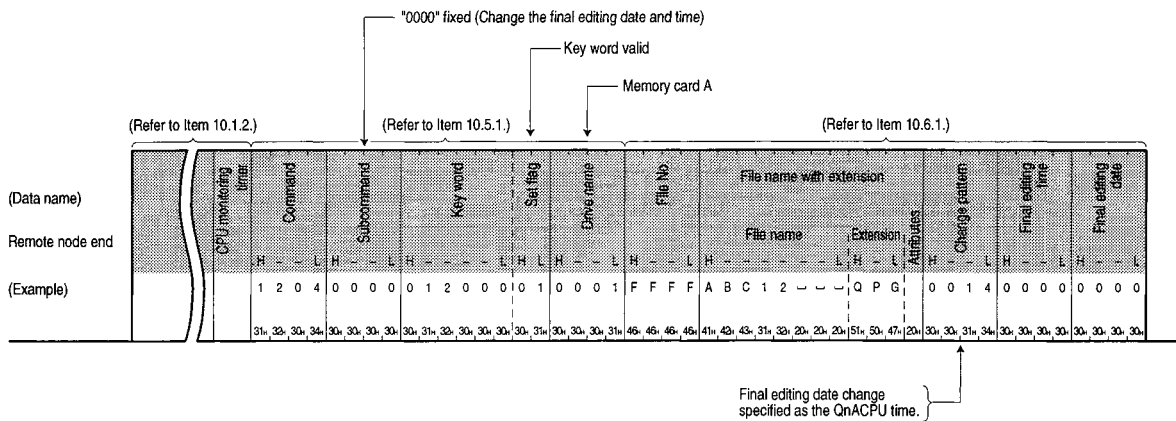

- (b) When changing the memory card A (RAM area, drive name : 01H) file name "ABC12.QPG" final editing time when using binary code for exchange
 (The file No. is unknown and the final editing time is specified as the QnACPU time.)

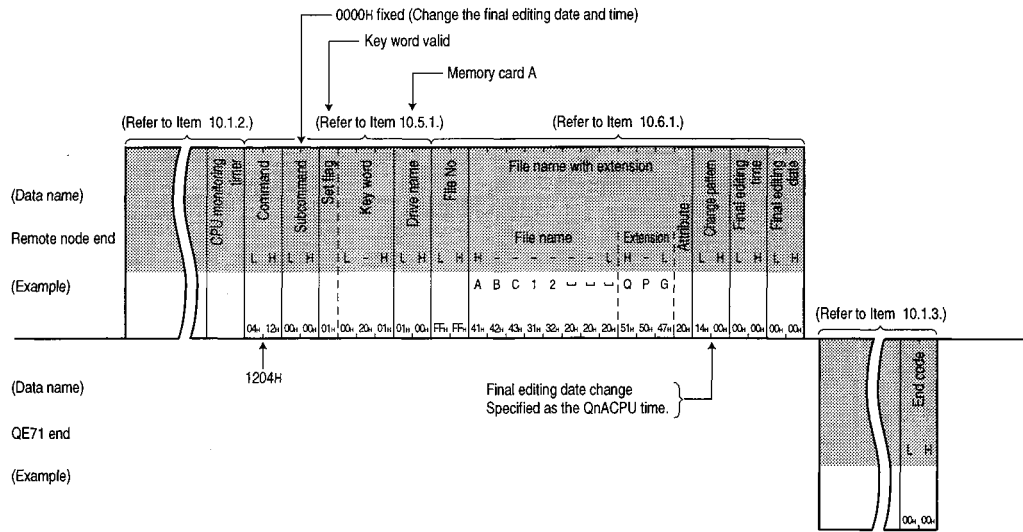

Point

- (1) Set the specification values within the following range.
 - File No. 1 ≤ file No. ≤ 256
 - Change pattern 04H, 08H, 0CH, 14H, 18H and 1CH
- (2) If the following files are specified when the QnACPU is running, an error will occur and an end code will be returned at the time of error.
 - Parameter file
 - Files currently executing in the internal RAM (drive name: 00H)

2 Changing the file name, attribute, and size (Command : 1204, subcommand : 0001)

This section uses an example to explain the specified file's file name, attribute, and file size change control procedure.

(Control procedure)

- (a) When changing the memory card A (RAM area, drive name : 01H) file No. is 1 and the file name is "ABC12.QPG" file name and attribute when using ASCII code for exchange
(Change the file name to "ABC1234.QPG" and the attribute to read only file.)

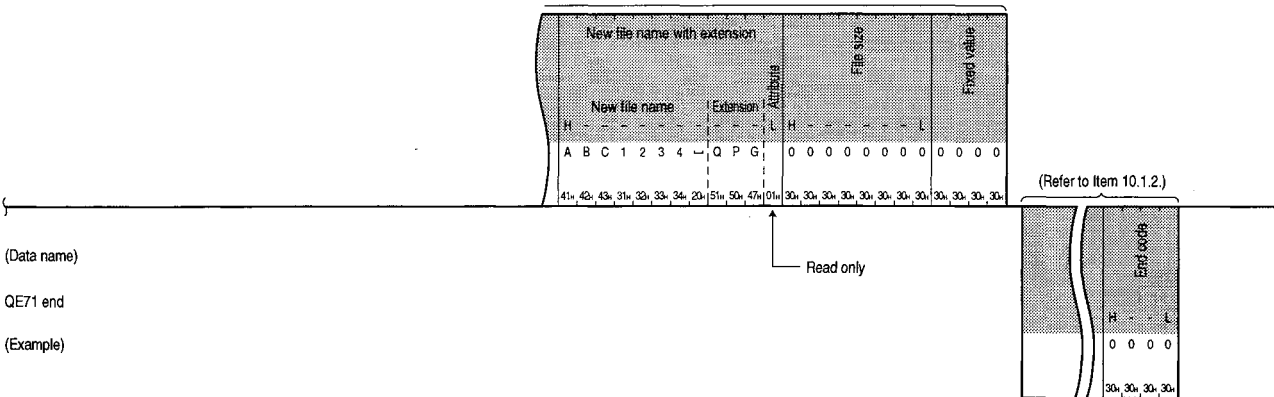
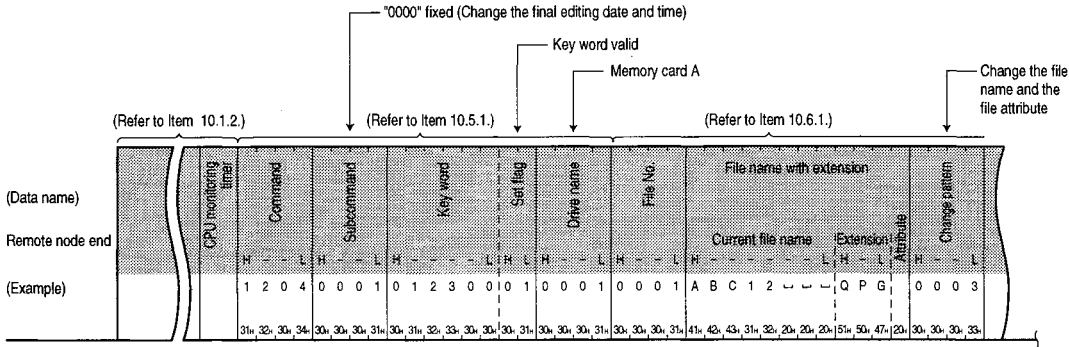

- (b) When changing the memory card A (RAM area, drive name : 01H) file No. is 1 and the file name is "ABC12.QPG" file name and attribute when using binary code for exchange (Change the file name to "ABC1234.QPG" and the attribute to read only file.)

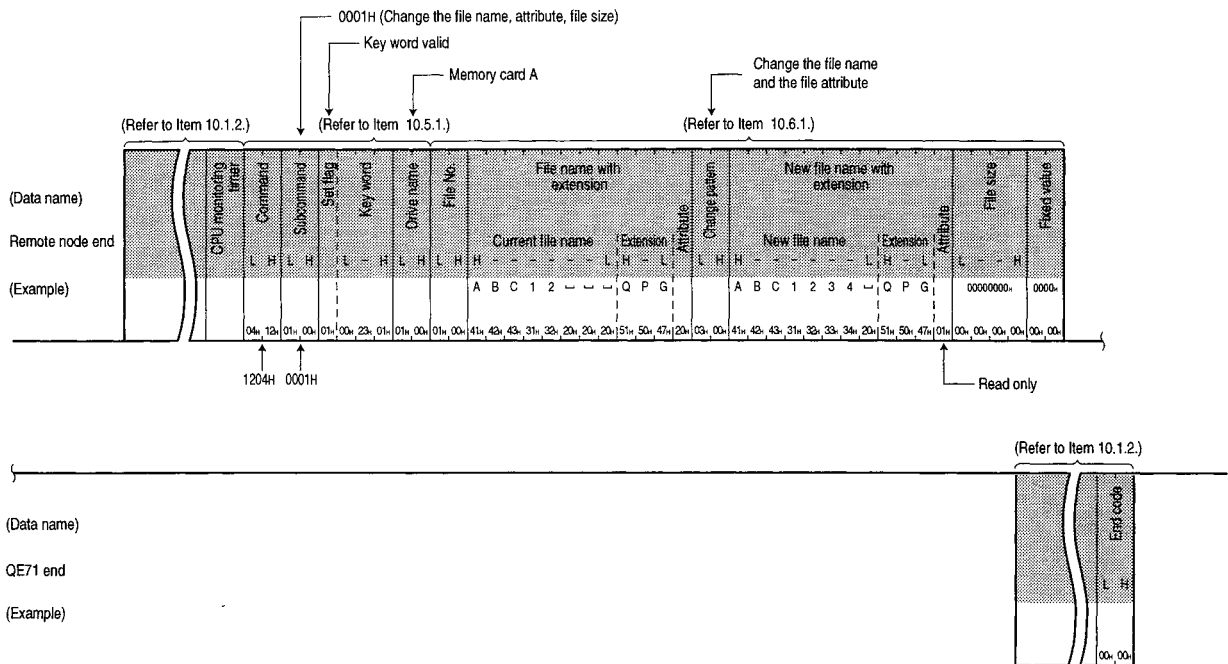

Point

- Set the specification values within the following range.
 - File No. 1 ≤ file No. ≤ 256
 - Change pattern 01H, 02H, 03H, 20H, 21H, 22H, and 23H
- If the following files are specified when the QnACPU is running, an error will occur and an end code will be returned at the time of error.
 - Parameter file
 - Files currently executing in the internal RAM (drive name : 00H)
- The attribute can be changed between 01H (read only file) and 20H (read and write possible disk file).
- Changing the size is only possible when the QnACPU is stopped and a continuous vacant area of the specified size in the specified drive is required.
 The vacant area can be checked using the memory usage state read described in Item 10.5.2.

3 Batch changing of file information (Command : 1204, subcommand : 0002)

This section uses an example to explain the specified file's file information batch change control procedure.

(Control procedure)

- (a) When changing the memory card A (RAM area, drive name : 01H) file No. is 1 and the file name is "ABC12.QPG" file name, attribute, final editing date and time when using ASCII code for exchange (The QnACPU date and time are used for the final editing date and time. Change the attribute to read only file.)

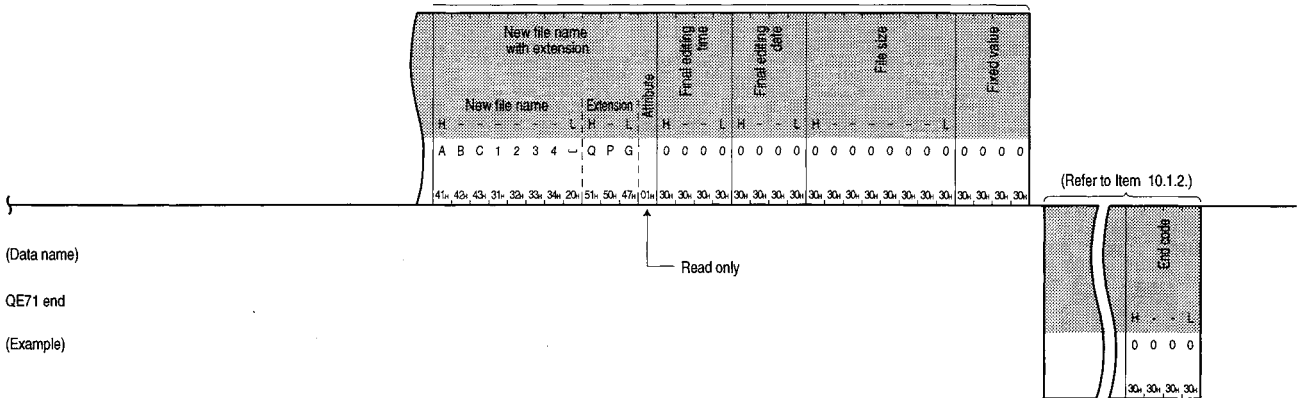
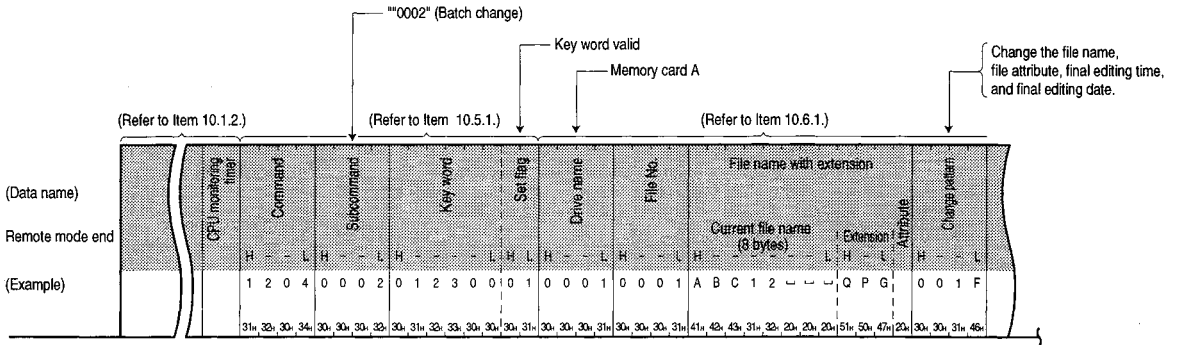

(b) When changing the memory card A (RAM area, drive name : 01H) file No. is 1 and the file name is "ABC12.QPG" file name, attribute, and final editing data and time when using binary code for exchange (The QnACPU date and time are used for the final editing date and time. Change the attribute to read only file.)

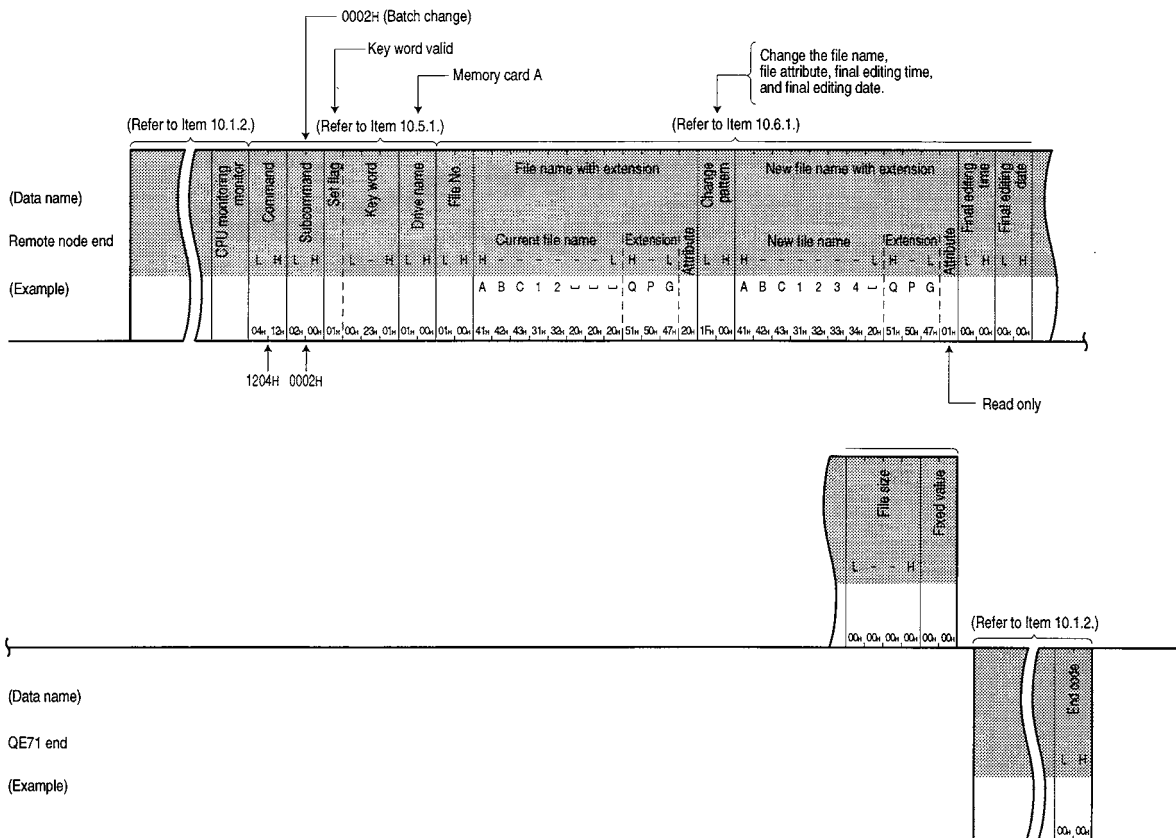

Point

- (1) Set the specification values within the following range.
 - File No. 1 ≤ file No. ≤ 256
 - Change pattern 01H ≤ change pattern ≤ 3FH
- (2) If the following files are specified when the QnACPU is running, an error will occur and an end code will be returned at the time of error.
 - Parameter file
 - Files currently executing in the internal RAM (drive name : 00H)
- (3) The attribute can be changed between 01H (read only file) and 20H (read and write possible disk file).
- (4) Changing the size is only possible when the QnACPU is stopped and a continuous vacant area of the specified size in the specified drive is required.
The vacant area can be checked using the memory usage state read described in Item 10.5.2.

10.6.6 Reading a File Existence (File Search) (Command : 0203)

This section uses an example to explain the specified file existence, file No. when exists, and file size read control procedure.

(Control procedure)

- 1 When reading the memory card A (RAM area, drive name : 01H) file name is "ABC12.QPG" exists when exchanging using ASCII code

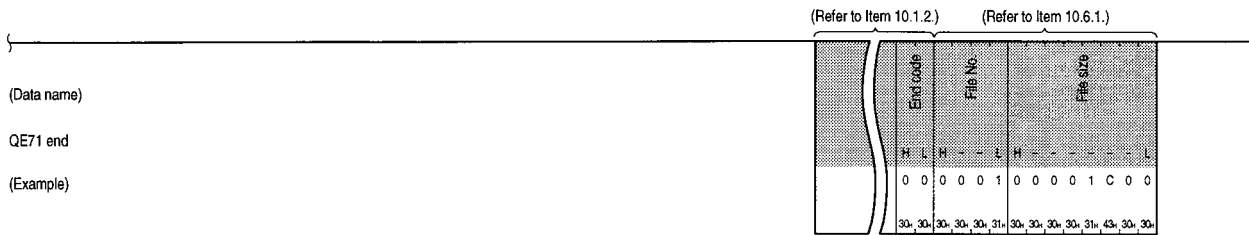
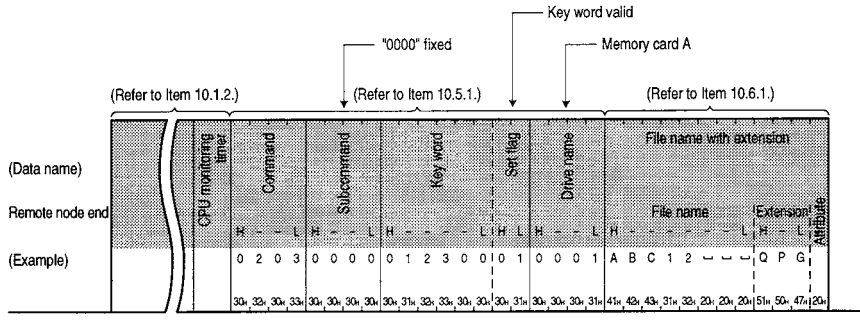

2 When reading the memory card A (RAM area, drive name : 01H) file name is "ABC12.QPG" exists when exchanging using binary code

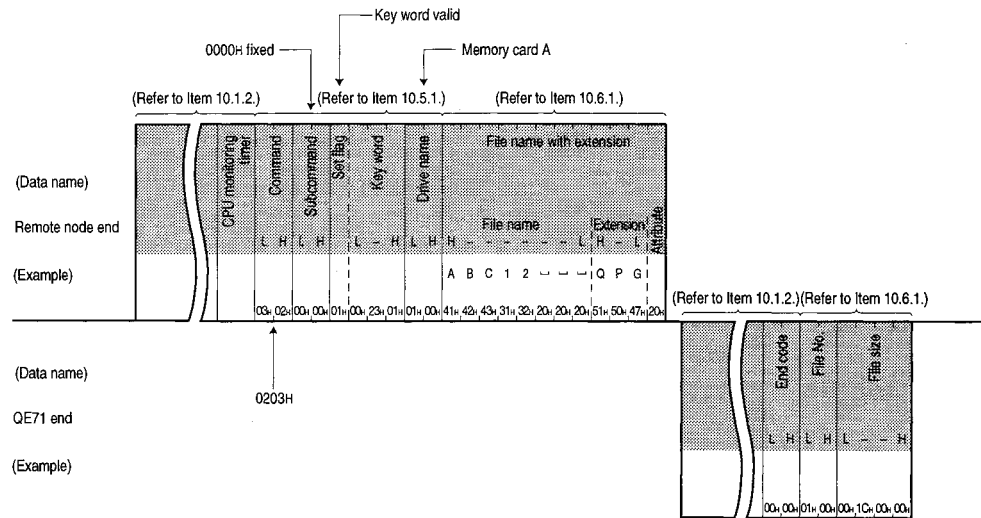

Point

- (1) Handle the read file attribute as dummy data.
- (2) When a specified file does not exist an error occurs and an end code is returned at the time of error.

10.6.7 Reading File Contents (Command : 0206)

This section uses an example to explain the read control procedure for the data being read from the specified file.

(Control procedure)

1 When reading 50 bytes from the memory card A (RAM area, drive name : 01H) file No. is 1 and the file name is "ABC12.QPG" offset address 100H when exchanging using ASCII code

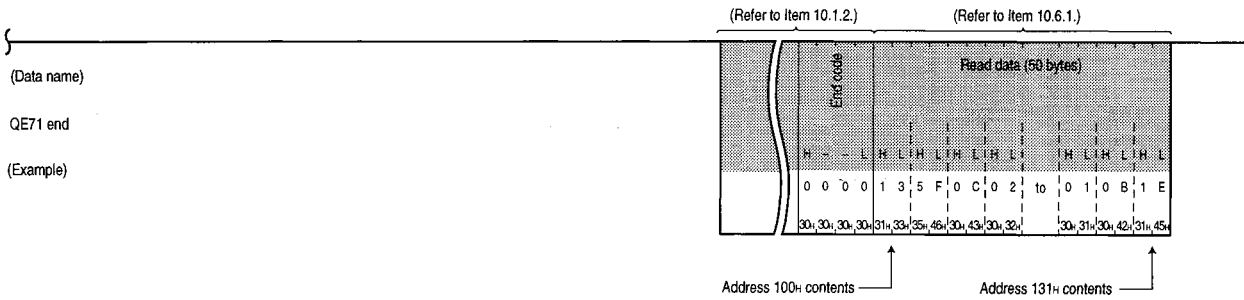
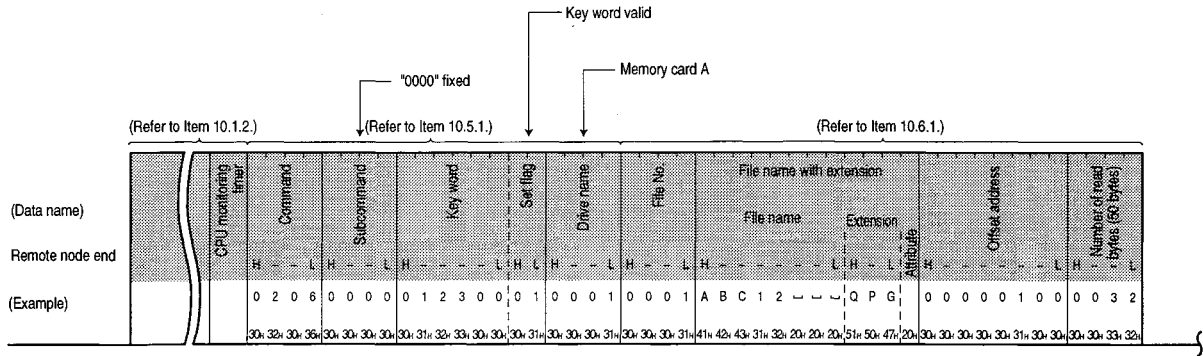

2

When reading 50 bytes from the memory card A (RAM area, drive name : 01H) file No. is 1 and the file name is "ABC12.QPG" offset address 100H when exchanging using binary code

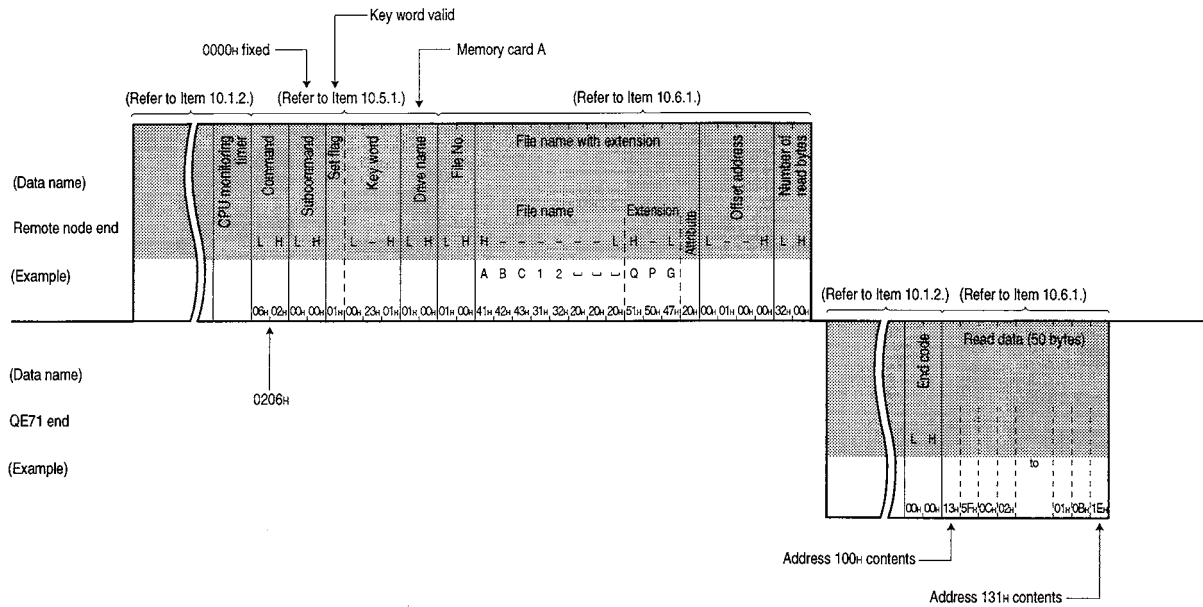

Point

- (1) The maximum number of bytes for 1 data read is set. Read the data written in the specified file by organizing the offset address and number of read bytes and breaking them into a number of sections. In addition store as is the data read from remote nodes.
The file size can be checked using the following functions.
 - File information list read function Item 10.6.4
 - File existence read function Item 10.6.6
- (2) Handle the read file attribute as dummy data.
- (3) Specify the specified values in the following range.
 - File No. 1 ≤ file No. ≤ 256
 - Offset address set to an even address within the following range
0 ≤ address ≤ (file size - 1)
 - Number of read bytes 0 ≤ number of bytes ≤ 960

10.6.8 Creating New Files (File Name Registration) (Command : 1202)

This section uses an example to explain the control procedure for registering a new file in the specified disk and procuring file area.

(Control procedure)

- When registering a new file of 172 bytes in size and obtaining file area in the memory card A (RAM area, drive name : 01H) when the file name is "ABC12.QPG" and exchange is conducted using ASCII code

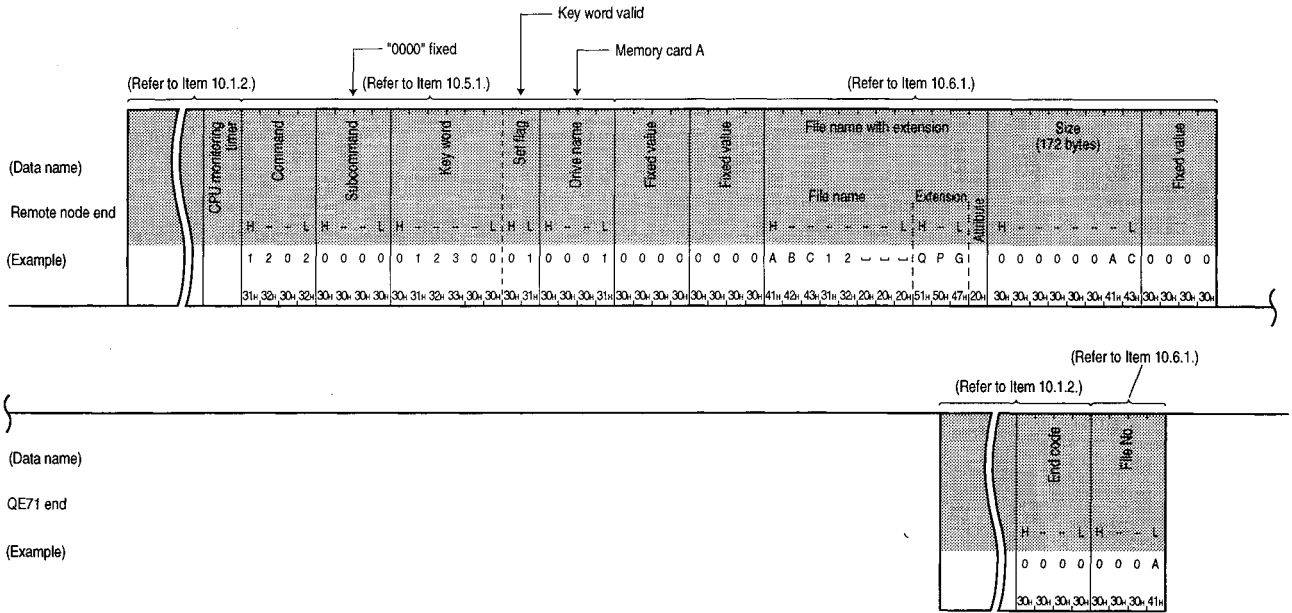

2 When registering a new file of 172 bytes in size and obtaining file area in the memory card A (RAM area, drive name : 01H) when the file name is "ABC12.QPG" and exchange is conducted using binary code

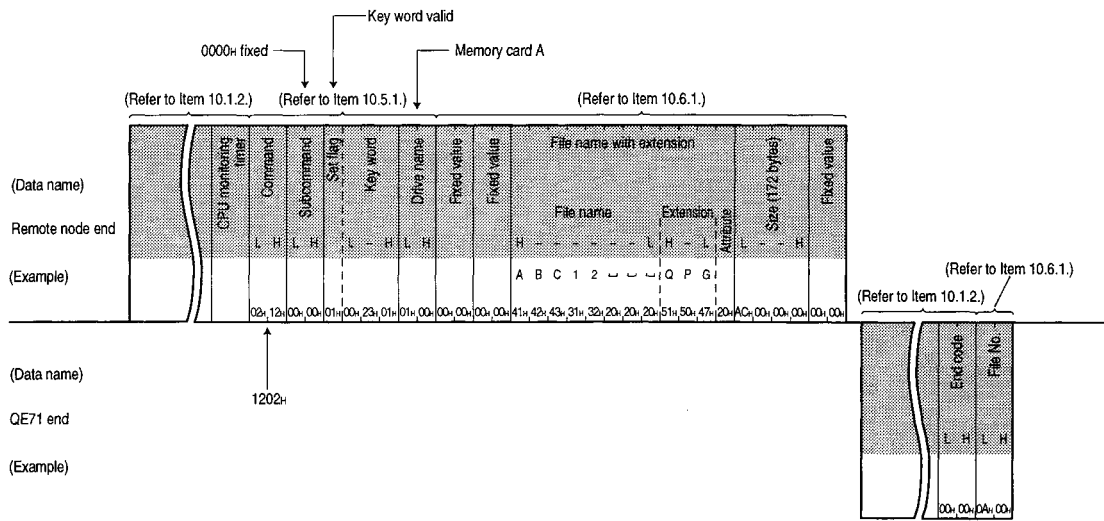

Point

- (1) Files can be newly created within the size of continuously unused clusters (Refer to Item 10.5) in the specified drive memory. When creating new files, it is desirable that consideration be given to later data additions when setting the file size.
- (2) Specify the newly created file's attribute as 20H (read/write possible disk file).
- (3) Use this command as a write (command : 1203) function to write data in the files described in Item 10.6.9 when creating new files. The contents of files that do not contain written data cannot be read.
- (4) Files newly created using this function use the QnACPU control time as the registered final editing date and time.

10.6.9 Writing to Files (Command : 1203)

1 Batch writing

This section uses an example to explain the control procedure for writing file data saved by a remote node after reading from the QnACPU into the specified file.

(Control procedure)

- (a) When writing the 416 bytes of data from the offset address 7CH into the memory card A (RAM area, drive name : 01H) file No. is 1 and the file name is "ABC12.QPG" when exchanging using the ASCII code

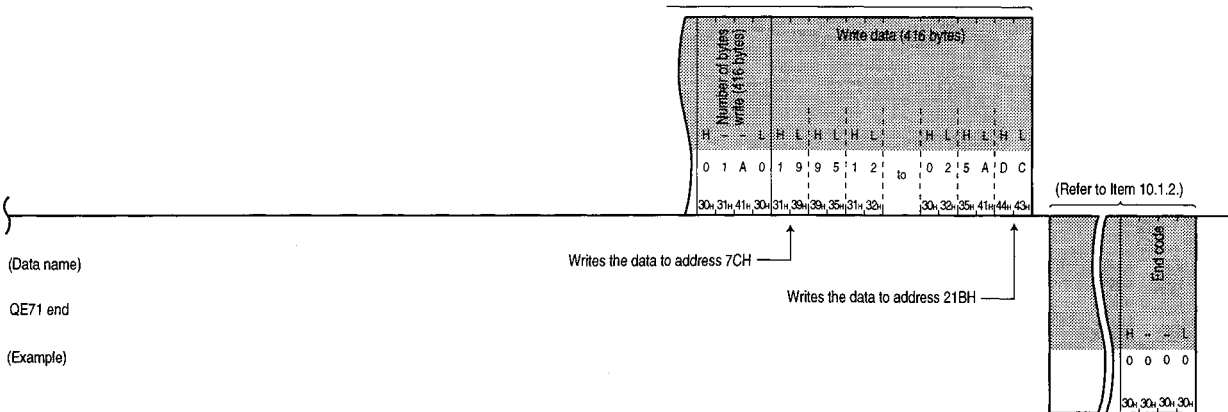
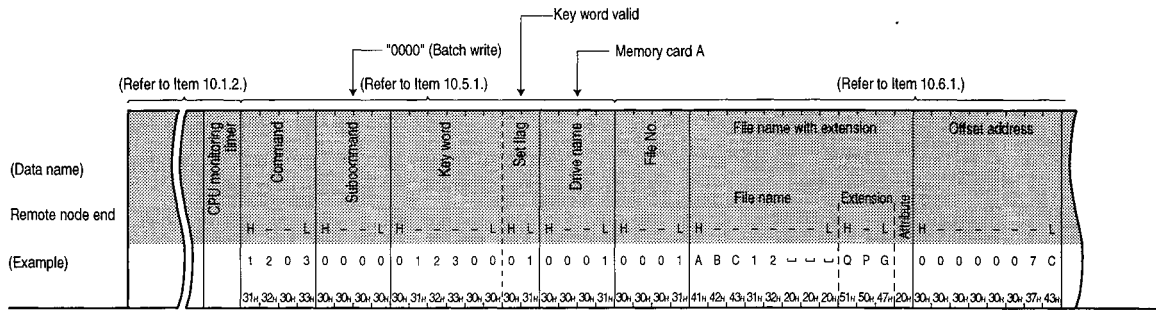

(b) When writing 416 bytes of data from the offset address 7CH into the memory card A (RAM area, drive name : 01H) file No. is 1 and the file name is "ABC12.QPG" when exchanging using binary code

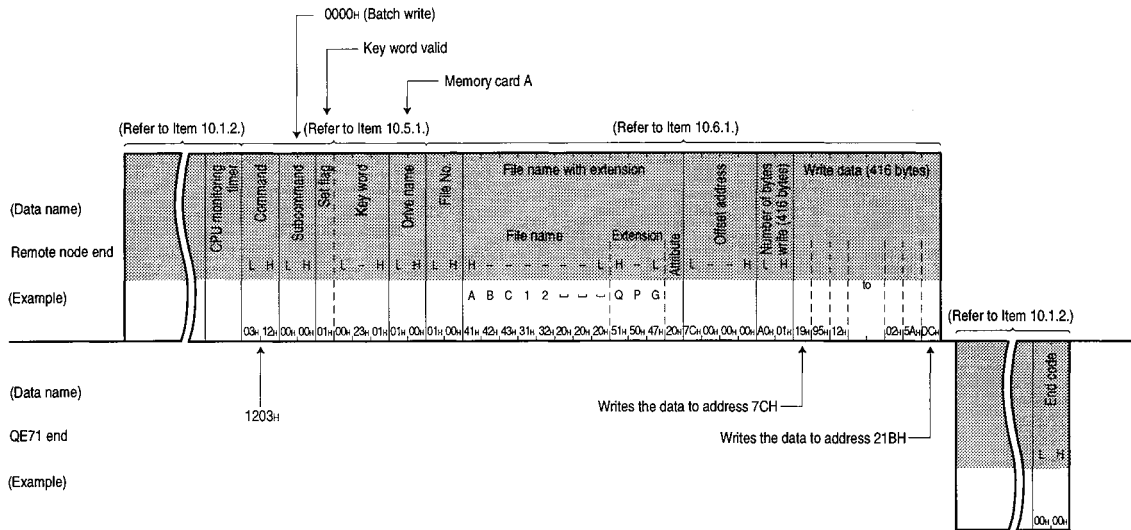

Point

- (1) The maximum number of bytes that can be written during 1 data write is set. Organize and divide into sections the offset address and number of write bytes of the data read from the QnACPU and stored by the remote node and write all these into the specified file.
- (2) The attribute of the file in which the data is written, such as attributes attached during new file creation, are valid as is. When writing data, use the attribute as dummy data.
- (3) An error will occur when the following files are specified while the QnACPU is running and an end code will be returned when the error occurs.
 - Parameter file
 - When a file currently executing in internal RAM (drive name : 00H)
- (4) Specify the specification values with the following range.
 - Offset address $0 \leq \text{address} \leq (\text{file size} - 1)$
 When writing to files for which the drive name is 00H (internal RAM), specify the address in the above range in multiples of 4 (for decimal : 0, 4, 8, ...).
 When writing to files with the drive name other than 00H, specify even addresses in the above range (for decimals : 0, 2, 4, 6, 8, ...).
 - Number of write bytes $0 \leq \text{number of bytes} \leq 960$

2 Writing the same data (FILL)

This section uses an example to explain the control procedure for writing the n bytes in the specified file for voluntary 1 word data.

(Control procedure)

- (a) When writing 416 bytes of FFFFH from the offset address 7CH to the memory card A (RAM area, drive name : 01H) file No. is 1 and the file name is "ABC12.QPG" file when exchanging using ASCII code

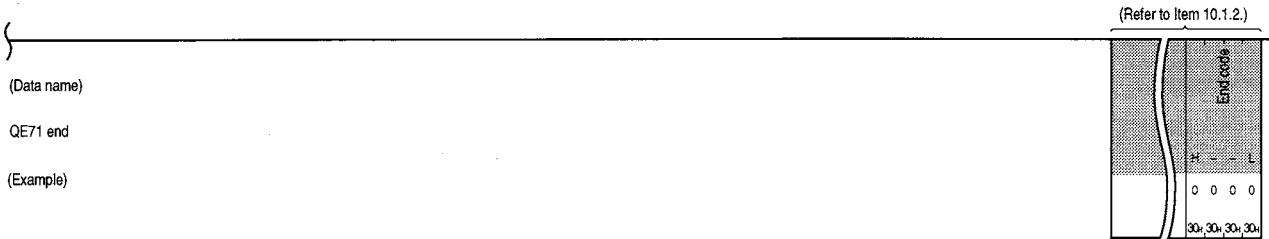
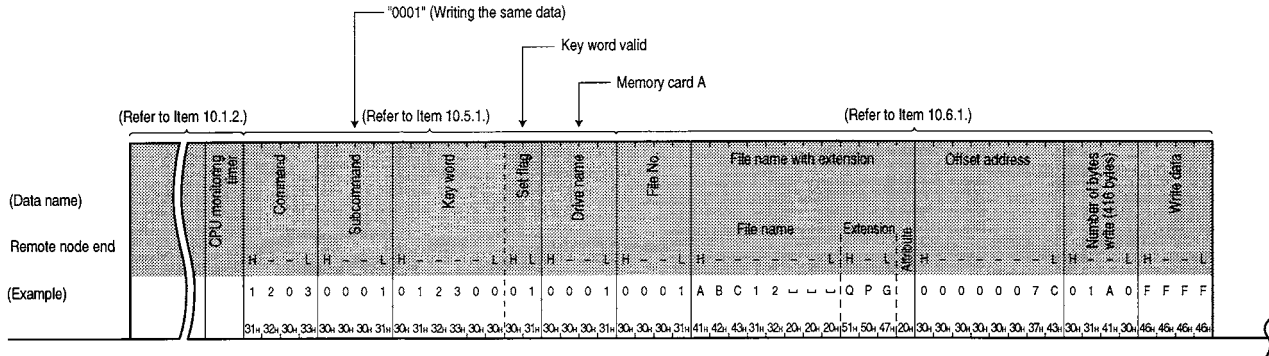

(b) When writing 416 bytes of FFFFH from the offset address 7CH from the memory card A (RAM area, drive name : 01H) file No. is 1 and the file name is "ABC12.QPG" file when exchanging using binary code

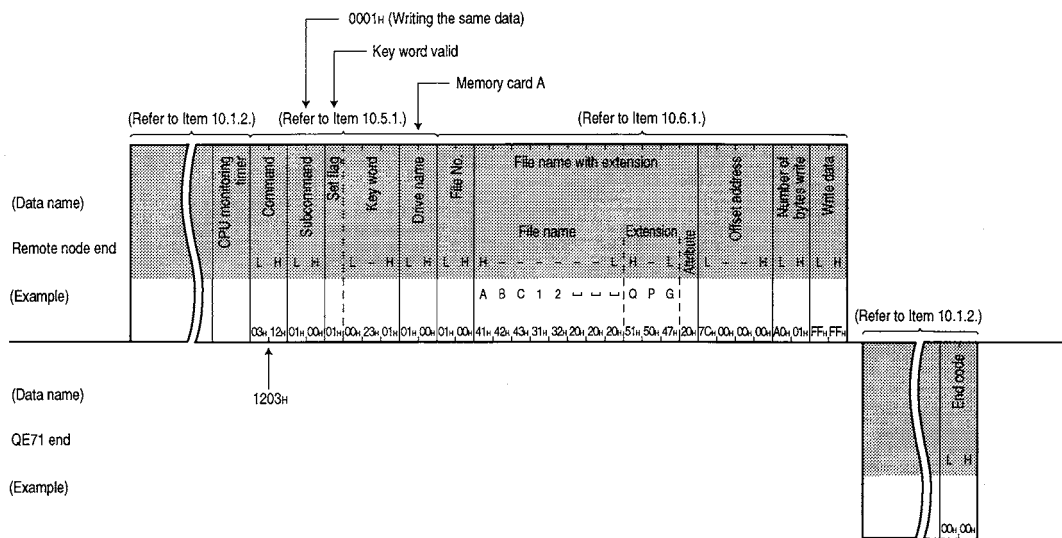

Point

- (1) The maximum number of bytes that can be written during 1 data write is set. Organize and divide into sections the offset address and number of write bytes of the voluntary 1 word data and write all these into the specified file.
- (2) The attribute of the file in which the data is written, such as attributes attached during new file creation, are valid as is. When writing data, use the attribute as dummy data.
- (3) An error will occur when the following files are specified while the QnACPU is running and an end code will be returned when the error occurs.
 - Parameter file
 - File currently executing in the internal RAM (drive name : 00H)
- (4) Specify the specification values with the following range.
 - Offset address $0 \leq \text{address} \leq (\text{file size} - 1)$
 When specifying a file when the drive name is 00H (internal RAM), specify the address within the above range in multiples of 4 (decimal : 0, 4, 8, ...).
 When writing to files with the drive name other than 00H, specify even addresses in the above range (decimals : 0, 2, 4, 6, 8, ...).
 - Number of write bytes $0 \leq \text{number of bytes} \leq 960$

10.6.10 Registering and Deleting File Lock (Command : 0808)

This section uses an example to explain the control procedure for controlling the QE71 using the following processing.

- File lock registration (Disable access by other equipment)
File lock registration is conducted to prevent access to the same file by other equipment to prevent other equipment from accessing the specified file and changing its contents.
- File lock delete (Enable access by other equipment)
Deletes the file lock for the file for which file lock was registered to allow other equipment to access the same file.

(Control procedure)

1 When conducting the normal execution mode for file lock registration for the memory card A (RAM area, drive name : 01H) file No. is 1 and the file name is "ABC12.QPG" file when exchanging using ASCII code

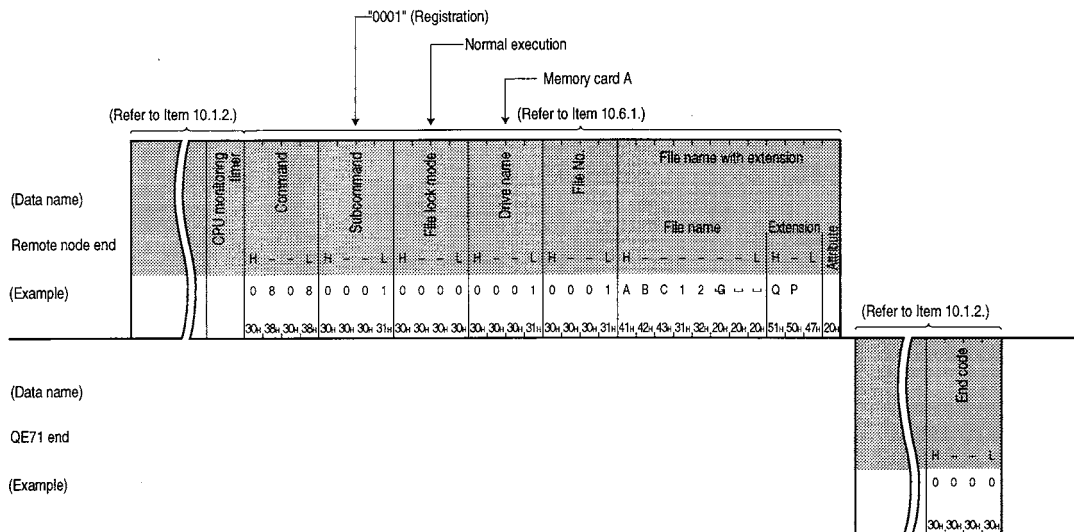

2 When conducting the normal execution mode for file lock registration for the memory card A(RAM area, drive name : 01H) file No. is 1 and the file name is "ABC12.QPG" file when exchanging using binary code

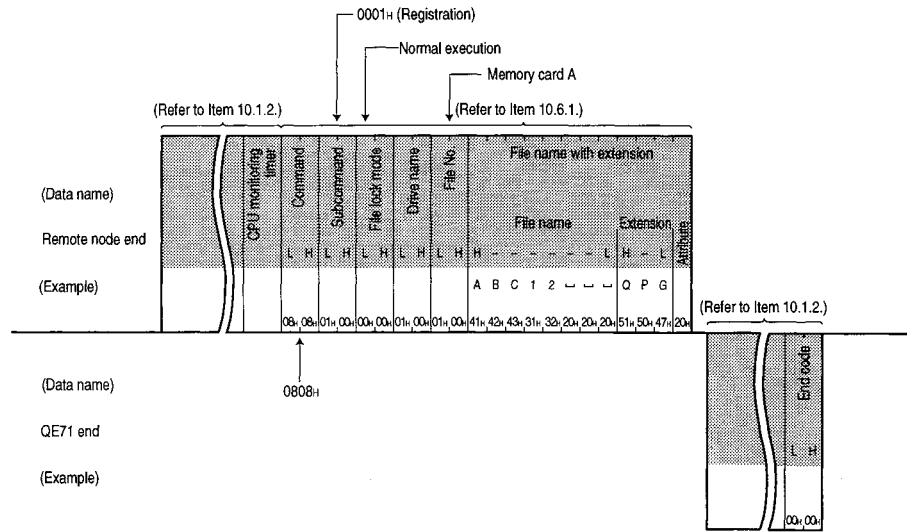

Point

- (1) The attribute added during new file creation is valid as is for the file attribute for which file lock registration and deletion is conducted. Handle the attribute as dummy data when registering and deleting the file lock.
- (2) When file lock is registered rebooting the QnACPU (CPU reset, etc.) will change it to the file lock delete state.

10.6.11 File Copy (Command : 1206)

This section uses an example to explain the control procedures for writing the data in an existing file to a newly created file.

(Control procedure)

- 1 When copying the contents of an existing file in the memory card A (RAM area, drive name: 01H) to a newly registered file when exchanging using ASCII code
- In either case, set the offset address 1E0H and copy 480 bytes.
- Existing file File No. : 0001H (1), file name : "ABC12.QPG"
- Newly registered file File No. : 000AH (10), file name : "ABC12001.QPG"
- (Does not copy the original file's final editing time.)

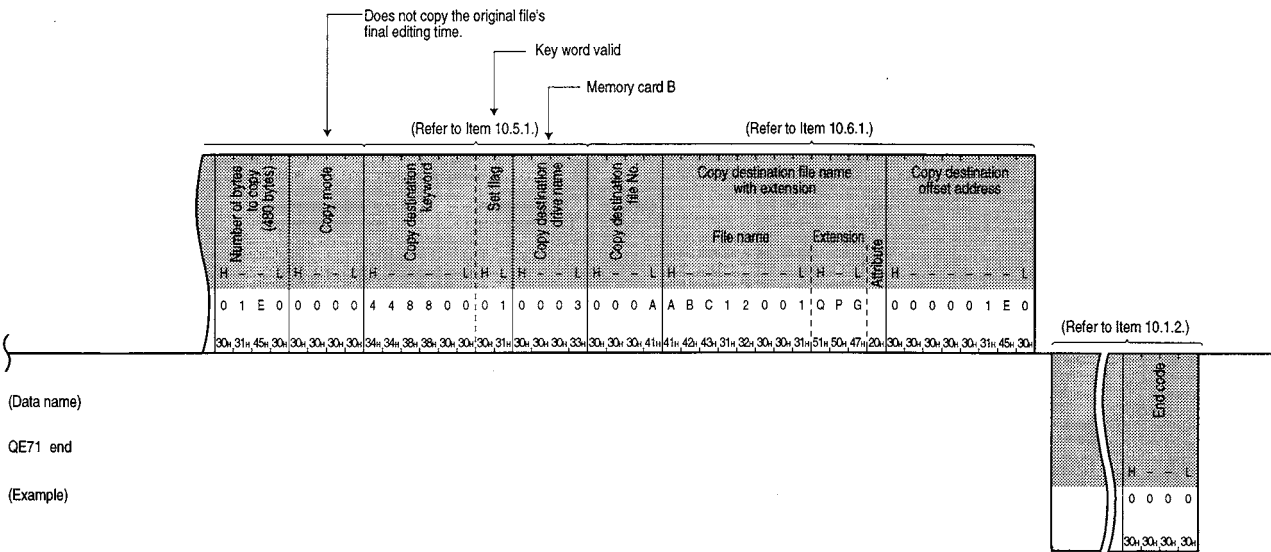
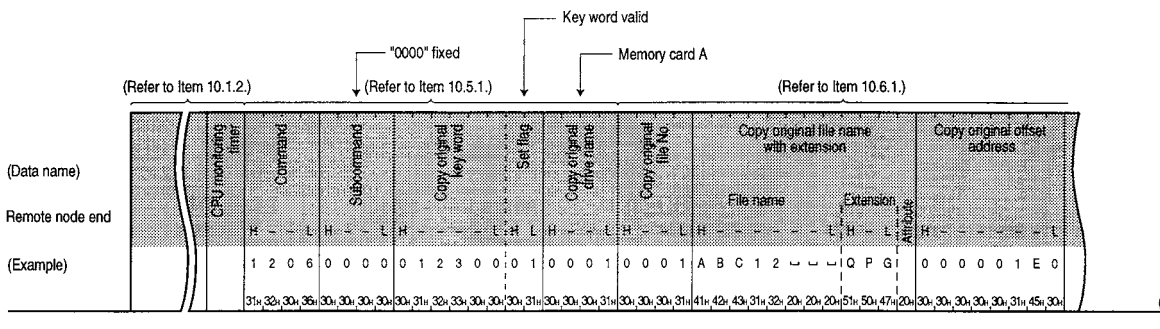

2 When copying the contents of an existing file in the memory card A (RAM area, drive name : 01H) to a newly registered file when exchanging using binary code

Specify either offset address 1E0H and copy 480 bytes.

Existing file File No. : 0001H (1), file name : "ABC12.QPG"

Newly registered file File No. : 000AH (10), file name : "ABC12001.QPQ"

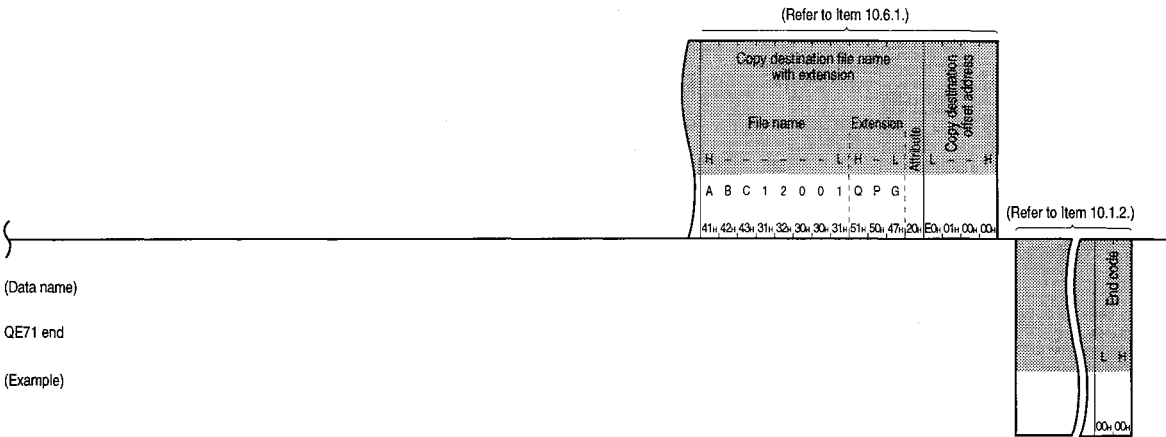
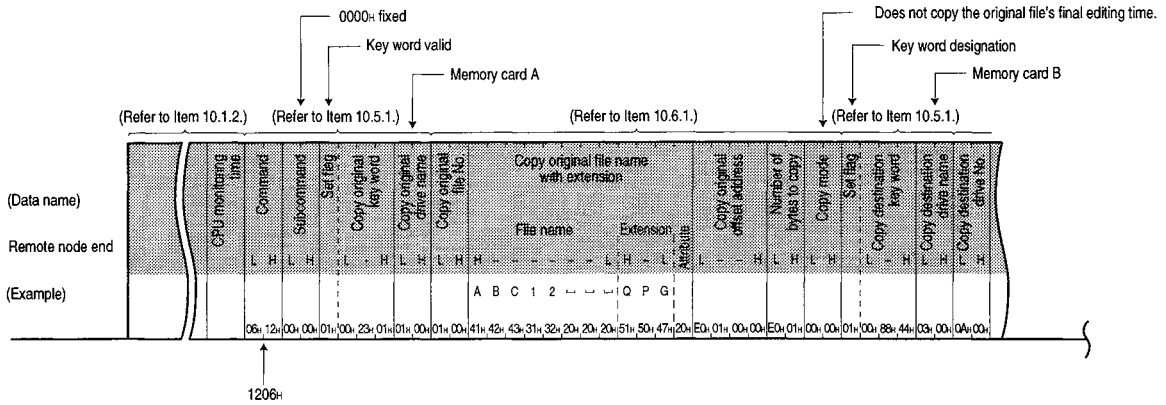

Point

- The maximum number of bytes that can be copied at one time is fixed.
Organize the offset address and number of copy bytes of the data written in the existing file and divide it into a number of sections and write all of these into the newly registered file.
- For the copy origin and copy destination file attribute, the attribute attached to the newly registered is valid as is. When copying, handle the attribute as dummy data.
- If the following files are specified when the QnACPU is running, an error will occur and an end code will be returned at the time of error.
 - Parameter file
 - File currently executing in the internal RAM (drive name : 00H)
- Specify the specification values with the following range.
 - Offset address $0 \leq \text{address} \leq (\text{file size} - 1)$
When specifying a file when the drive name is 00H (Built-in RAM), specify the address within the above range in multiples of 4 (decimals : 0, 4, 8, ...).
When specifying a file with a drive name other than 00H, specify in the above range an even address (decimals : 0, 2, 4, 6, 8, ...).
 - Number of copy bytes $0 \leq \text{number of bytes} \leq 480$

10.6.12 Deleting Files (Command : 1205)

This section uses an example to explain the control procedure for deleting existing files.

(Control procedure)

- 1 When deleting existing files of the memory card A (RAM area, drive name : 01H) with the file name of "ABC12.QPG" when exchanging using ASCII code

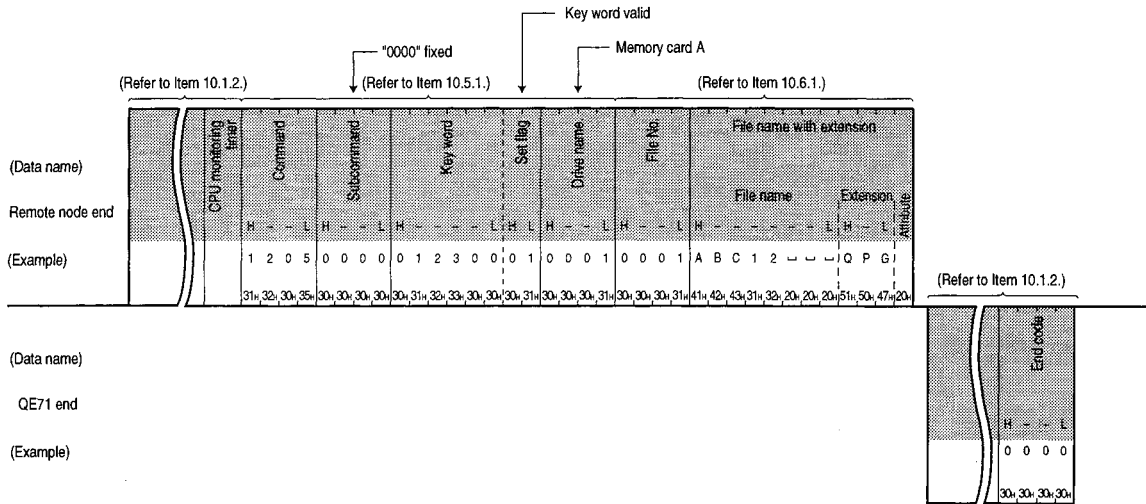

2 When deleting existing files of the memory card A (RAM area, drive name : 01H) with the file name of "ABC12.QPG" when exchanging using binary code

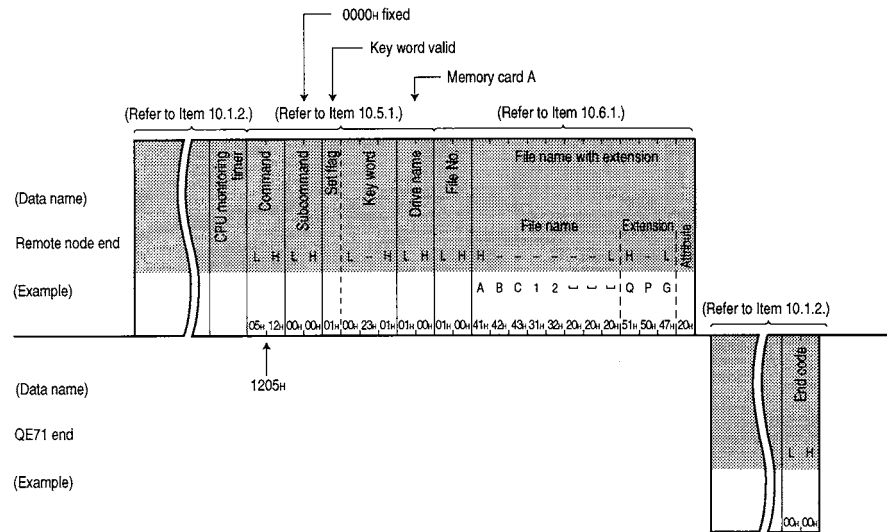

Point

- (1) For the attribute of the file to be deleted, the attribute attached to the newly created file is valid as is.
During the deletion handle the attribute as dummy data.
- (2) For the timing when deleting the files, make arrangements with the overall system including the QnACPU and related equipment.
- (3) Files for which file locks have been registered cannot be deleted.
- (4) The following files cannot be deleted while the QnACPU is running.
 - Program file (.QPG)
 - Parameter file (.QPA)
 - Boot settings file (.QBT)

10.7 Registering and Reading EEPROM Parameters (Setting Values)

This function is used to register and read from a remote node the various setting values (parameters set in the QE71 buffer memory) for the EEPROM built into the QE71.

This section uses an example to explain the control procedure for this function.

Point

- (1) Only the parameters for the following buffer memories can be registered and read.
Register the setting values following the explanations given in the explanation items for each parameter.

Parameter name	Supported buffer memory address	Parameter explanation Item
Initial processing parameter setting area	0 to 1FH (0 to 31)	Item 5.2.2
Exchange parameter setting area	20 to 5FH (32 to 95)	Item 5.5.1
Exchange instruction area during STOP	67H (103)	Chapter 16
Subnet mask setting area	200 to 201H (512 to 513)	Item 11.2
Router relay parameter setting area	202 to 225H (514 to 549)	Item 12.4
Station No. <-> IP information setting area	228 to 3AAH (552 to 938)	Item 15.3.5
FTP parameter setting area	3B0 to 3BFH (944 to 959)	Item 13.3

- (2) For an explanation regarding the method for registering and reading from the PLC CPU, refer to Item 4.9.
- (3) This function can only be used by remote nodes that are on the same Ethernet as the QE71. This function cannot be used for the QE71 via data link systems or network systems.
- (4) This function's exchange is conducted when issued without waiting for PLC CPU's end processing when the remote node issues a registration/read request. The transmission time T1 described in Item 9.1 is always "0" for exchange with this function.

10.7.1 Command and Character Area Contents

This section explains the character area in the commands and control procedure when the various setting values (parameters) are registered, etc., to the QE71's EEPROM from the remote node.

1 Command

Functions	Command (Subcommand) * For ASCII code: Specify each ASCII code. For binary code: Specify each numeral as hexadecimal numeral.	Description of processing	Number of points processed per 1 exchange		PLC CPU state			Reference Item
			Access station-1 (Refer to Item 9.2.1*7)	Access station-2 (Refer to Item 9.2.1*8)	During STOP	During RUN		
						Write possible setting	Write not possible setting	
Read from EEPROM	0 6 1 1 (0 0 0 0)	Reads the parameters from the EEPROM.	480 words (960 bytes)	(Not possible)	○	○	○	Item 10.7.2
Registration to EEPROM	1 6 1 1 (0 0 0 0)	Registers the parameters to the EEPROM.			○	○	○	Item 10.7.3

○ in the PLC CPU state column of the above table shows that execution is possible.

2

Character area contents

This section explains the character area contents when registration etc. of the various setting values (parameters) are conducted for the QE71's EEPROM from a remote node.

(a) Head address

If data is used to show the head address of the EEPROM in the range that performs the registration and reading for the EEPROM.

Specify the same address as the buffer memory in which the target parameters are stored (being stored).

① Data exchange using ASCII code

The target buffer memory address is converted to ASCII code 4 digits (hexadecimal) and transmitted from the first digit.

② Data exchange using binary code

The 2-byte numerical that shows the target buffer memory address is transmitted from the Low byte (L : bits 0 to 7).

(b) Request number of words, written number of words

This data is used to specify the parameter registration range (or read range) number of addresses (number of words).

① Data exchange using ASCII code

The target buffer memory number of addresses 1H to 1E0H (1 to 480) is converted to ASCII code 4 digits (hexadecimal) and transmitted from the first digit.

② Data exchange using binary code

The target buffer memory number of addresses 1H to 1E0H (1 to 480) shown by the 2-byte numerical value is transmitted from the Low byte (L : bits 0 to 7).

(c) Number of read words

This data shows the number of addresses (number of words) in the range for which the parameters were read.

① Data exchange using ASCII code

The target buffer memory number of addresses 1H to 1E0H (1 to 480) is converted to ASCII code 4 digits (hexadecimal) and transmitted from the first digit.

② Data exchange using binary code

The target buffer memory number of addresses 1H to 1E0H (1 to 480) that is shown by the 2-byte numerical value is transmitted from the Low byte (L : bits 0 to 7).

Remarks

Specify the data for the QE71 installed station in the following data setting items in the message.

Data name	Setting value	Remarks
Network No.	00H	_____
PLC No.	FFH	

10.7.2 Reading Parameters (Command : 0611)

This section uses an example to explain the control procedure for reading parameters from the EEPROM.

(Control procedure)

- 1 When reading 3 words from the EEPROM address 29H to 2BH (41 to 43) contents when exchanging using ASCII code

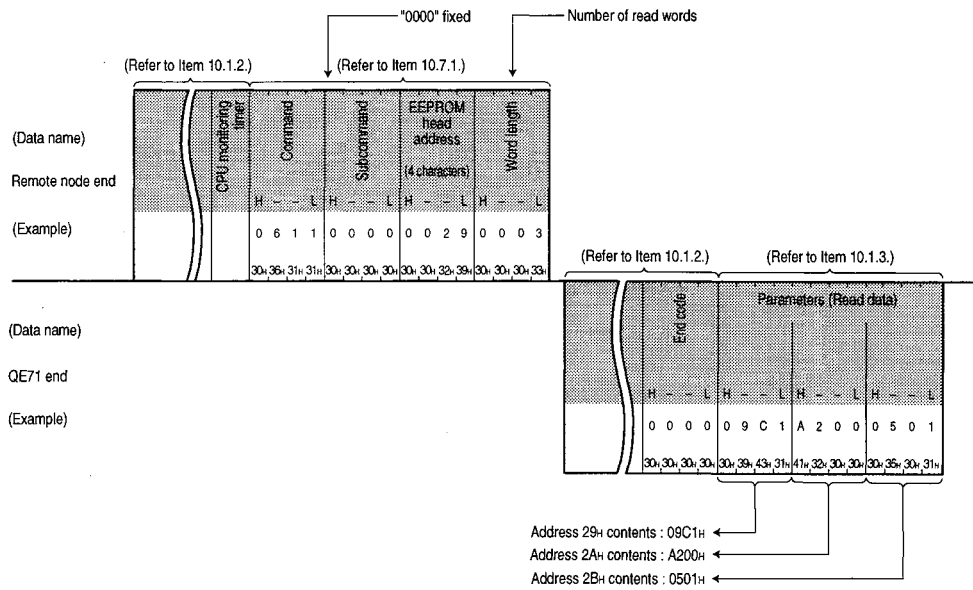

2 When reading 3 words from the EEPROM address 29H to 2BH (41 to 43) contents when exchanging using binary code

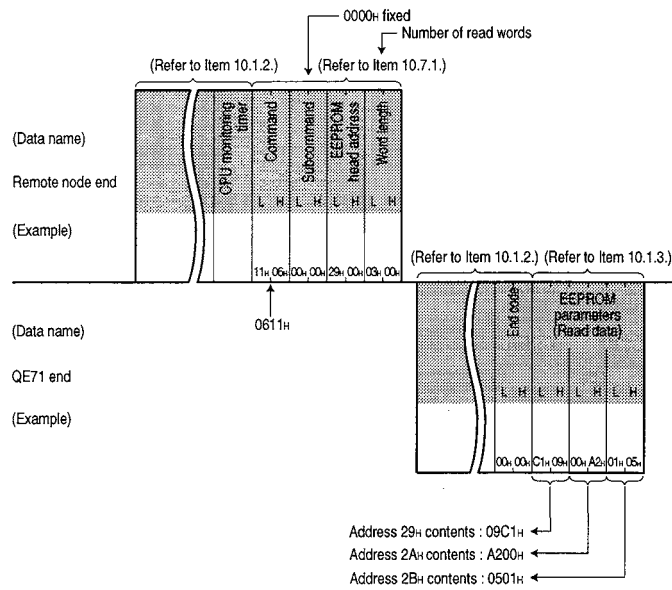

Point

- (1) Specify the head address and word length within the following range.
 - Head address $0H \leq \text{head address} \leq 3BFH$ (959)
 - Word length $1H \leq \text{word length} \leq 1E0H$ (480)
 - Access range $(\text{Head address} + \text{Word length} - 1) \leq 3BFH$ (959)
- (2) Only data which has been written (registered) successfully to the EEPROM can be read.
When erroneous data has been requested for read, an error results.

10.7.3 Registering Parameters (Command : 1611)

This section uses an example to explain the control procedure for registering parameters to the EEPROM.

(Control procedure)

- 1 When registering 3 words of data to the EEPROM address 29H to 2BH (41 to 43) when exchanging using ASCII

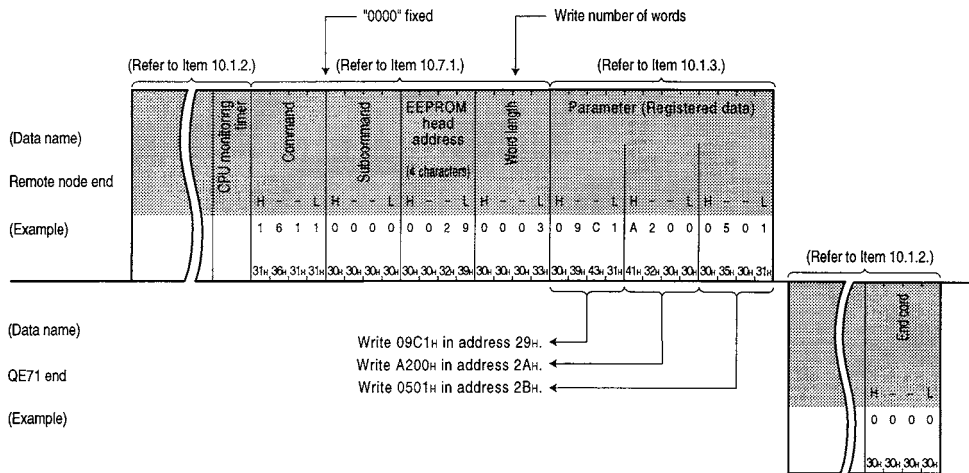

2 When registering 3 words of data to the EEPROM address 29H to 2BH (41 to 43) when exchanging using binary code

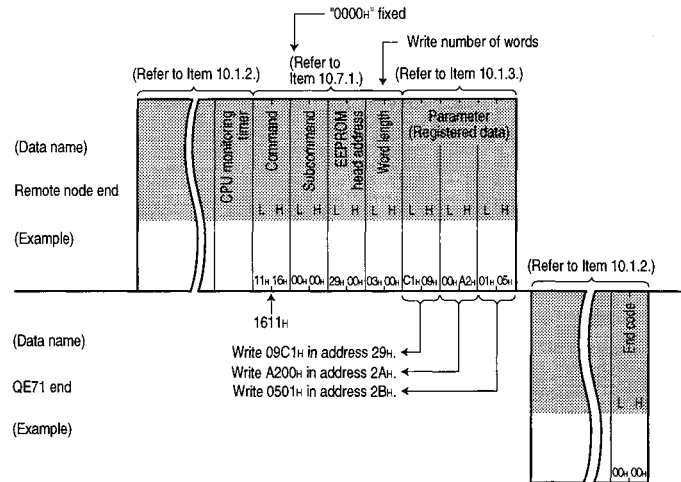

Point

Specify the head address and word length within the following range.

- Head address 0H ≤ head address ≤ 3BFH (959)
- Word length 1H ≤ word length ≤ 1E0H (480)
- Access range (Head address + Word length - 1) ≤ 3BFH (959)

10.8 Turning Off COM.ERR LED

This function is used by the remote node to turn off the COM.ERR LED on the front of the QE71.

Point

This function can only be used when the remote node that requests the COM.ERR LED to be turned off is on the same Ethernet as the QE71.

This function cannot be used for a remote station QE71 via a link data system or network system.

10.8.1 Command and Character Area Contents

This section explains the character area of the commands and control procedure when a remote node turns off the QE71's display LED.

1 Command

Functions	Command (Subcommand) * For ASCII code: Specify each ASCII code. For binary code: Specify each nu- meral as hexa- decimal numeral.	Description of processing	Number of points pro- cessed per 1 exchange		PLC CPU state			Reference Item
			Access station-1 (Refer to Item 9.2.1 ⁷)	Access station-2 (Refer to Item 9.2.1 ⁸)	During STOP	During RUN		
						Write pos- sible setting	Write not pos- sible setting	
Turn off display LED	1 6 1 7 (0 0 0 □)	Turns off the display LED.	(For 1 station)	(Not possible)	○	○	○	Item 10.8.2

○ in the PLC CPU state column of the above table shows that execution is possible.

2 Character area contents

Only transmit in combination with exchange codes that match the subcommand.

(a) Subcommand

① Data exchange using ASCII code

The "0000" is converted to the ASCII code 2 digits (hexadecimal) and transmitted from the first digit.

② Data exchange using binary code

The 0000H is transmitted.

10.8.2 Turning Off COM.ERR LED (Command : 1617)

This section uses an example to explain the control procedure for the remote node turning off the display LED on the front of the QE71.

(Control procedure)

1 When turning off the COM.ERR LED when exchanging using ASCII code

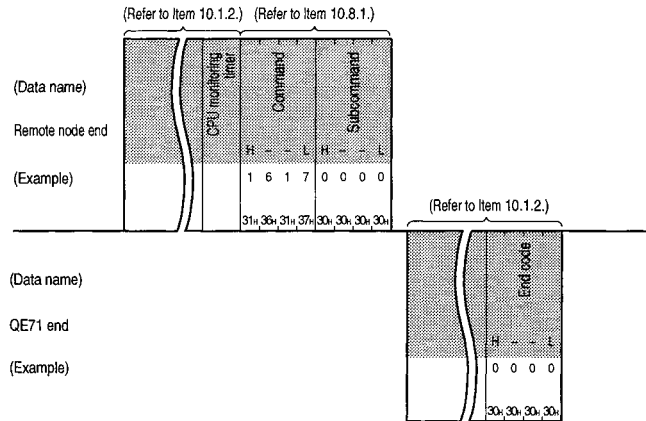

2 When turning off the COM.ERR LED when exchanging using binary code

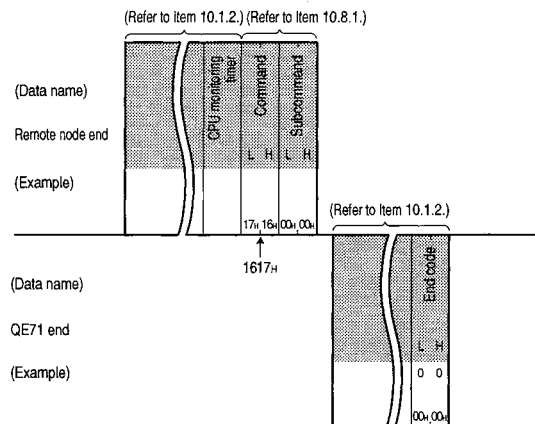

10.9 Loopback Test

Loopback test is a function that is used to test whether or not the exchange functions between a remote node and a QE71 are operating properly. This section uses an example to explain the control procedure for using this function.

Point

- (1) This loopback test can be used to check if the connection and data exchange functions between the remote node and the QE71 are operating properly when the QE71 is booted up and when trouble occurs.
- (2) This function can only be used for remote nodes that are on the same Ethernet as the QE71. This function cannot be used for a remote station QE71's via data link systems or network systems.

10.9.1 Command and Character Area Contents

This section explains the character area in commands and the control procedure for when a loopback test is conducted from a remote node to the QE71.

1 Command

Functions	Command (Subcommand) * For ASCII code: Specify each ASCII code. For binary code: Specify each numerical as hexadecimal numeral.	Description of processing	Number of points processed per 1 exchange		PLC CPU state			Reference Item
			Access station-1 (Refer to Item 9.2.1*7)	Access station-2 (Refer to Item 9.2.1*8)	During STOP	During RUN		
						Write possible setting	Write not possible setting	
Loopback test	0 6 1 9 (0 0 0 0)	Confirms whether the data exchange is conducted normally.	960 Bytes	(Not possible)	○	○	○	Item 10.8.2

○ in the PLC CPU state column of the above table shows that execution is possible.

2 Character area contents

This section explains the character area contents for when a loopback test is conducted by a remote node to the QE71.

(a) Number of loopback test data

This data is used to show the number of bytes in the loopback data portion.

① Data exchange using ASCII code

The number of bytes is converted to ASCII code 4 digits (hexadecimal) and transmitted from the first digit.

② Data exchange using binary code

The 2-byte numerical value shown for the number of bytes is transmitted from the Low byte (L : bits 0 to 7).

(b) Loopback data

This data is used to specify the user data in the message that is used for data transmission and reception in the loopback test.

① Data exchange using ASCII code

A maximum of 960 characters in half-width characters (0 to 9, A to F) is transmitted from the head.

② Data exchange using binary code

The character code for each half-width character (0 to 9, A to F) has a numerical value of 1 byte and a maximum of 960 bytes is transmitted from the head character code.

10.9.2 Loopback Test (Command : 0619)

This section uses an example to explain the control procedure for performing a loopback test from the remote node to the QE71.

(Control procedure)

1 When conducting a loopback test (Loopback data is "ABCDE") when exchanging using ASCII code

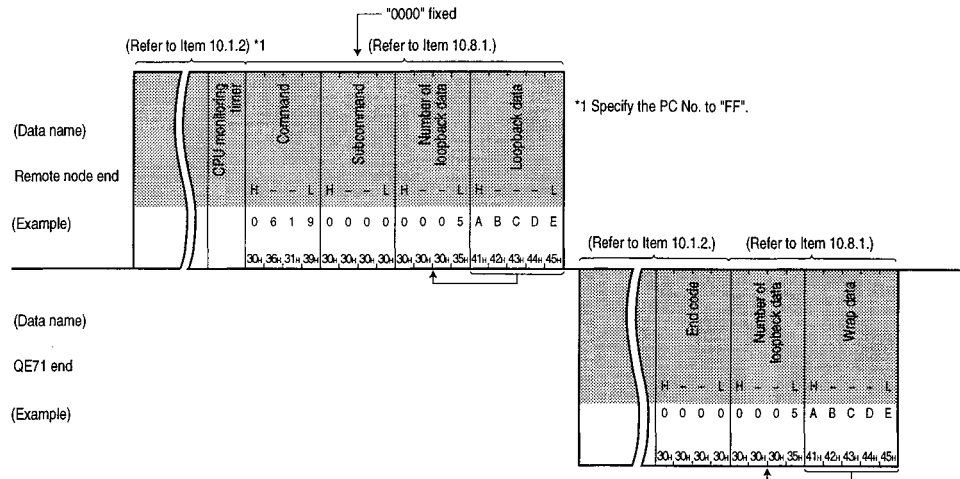

2 When conducting a loopback test (Loopback data is "ABCDE") when exchanging using binary code

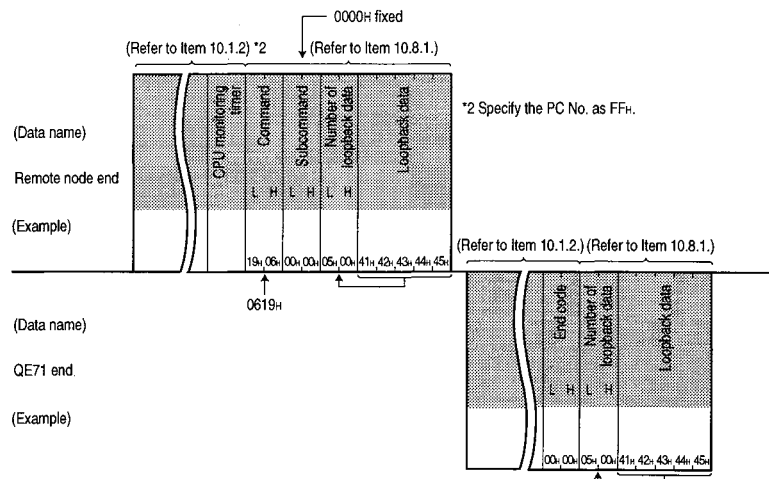

Point

The number of loopback data and the loopback data transmitted from the remote node can be returned to the remote node as the same contents.

SPECIAL FUNCTIONS SECTION

The special functions section gives a function summary and explains the usage method for the special functions used by the QE71 by dividing the section into one chapter per function.

The user needs to read the chapter that explains the function to be used.

- Chapter11 WHEN SETTING A SUBNET MASK
- Chapter12 WHEN USING ROUTER RELAY FUNCTIONS
- Chapter13 WHEN USING FILE TRANSFER FUNCTIONS
- Chapter14 WHEN THE QnACPU ACCESSES THE REMOTE STATION PLC USING THE DATA LINK INSTRUCTION
- Chapter15 WHEN EXCHANGING WITH MELSECNET/10 RELAY
- Chapter16 WHEN EXCHANGING WHILE PLC CPU IS STOP

11. WHEN SETTING A SUBNET MASK

When multiple nodes are connected to one network and that network is divided and managed as virtual multiple subnetworks, then subnet mask must be set for the corresponding nodes. This chapter explains how to set subnet masks.

11.1 Subnet Mask

Networks build with Ethernet consist of small size network systems where multiple nodes are connected to one Ethernet and medium and large size network systems where these smaller networks are connected using multiple routers.

The IP address of nodes connected to the Ethernet show the nodes address on that network, so three classes from class A through class C are provided to make it possible to select the address system that meets the needs of a particular network size, and the corresponding IP address is expressed using 32-bit numerical values. (Refer to Item 11.3)

Subnet masks make is easy to logically divide one network that has many nodes connected to it into multiple subnetwork units that are easy to manage.

In particular this is information that uses a part of the host address as a network address extension as recognizes it as the subnet address shown below.

(Example using class B)

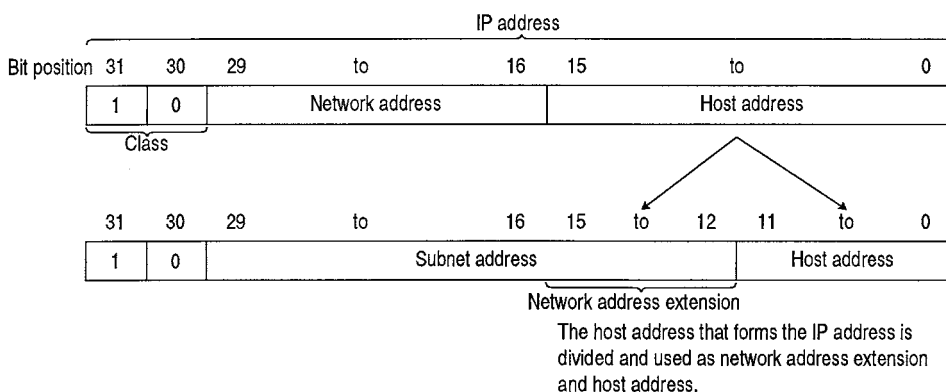

Point

- (1) All nodes on the same subnetwork must have a common subnet mask.
For details of transmission from QE71 when the subnet address of the data transmission destination node differs from the local station, refer to Chapter 12.3, "Overview of Router Relay Processing."
- (2) If not managed as a subnetwork then each node does not have to have a subnet mask.

With the QE71, the subnet mask is set in the subnet mask setting area (subnet mask field) in the buffer memory. Up to which area is used in the host address as the extension, as shown below, is specified.

- ① The location up to where one subnet mask field is created becomes the network address + network address extension and the QE71 handles this portion as a subnet address.
 - ② If the subnet address differ, they will be viewed as separate networks.
- * When Ethernet are connected using routers, specifying a subnet address makes it possible to see which router is managing which network.

(Example) When FFFF000H is used as the class B subnet mask

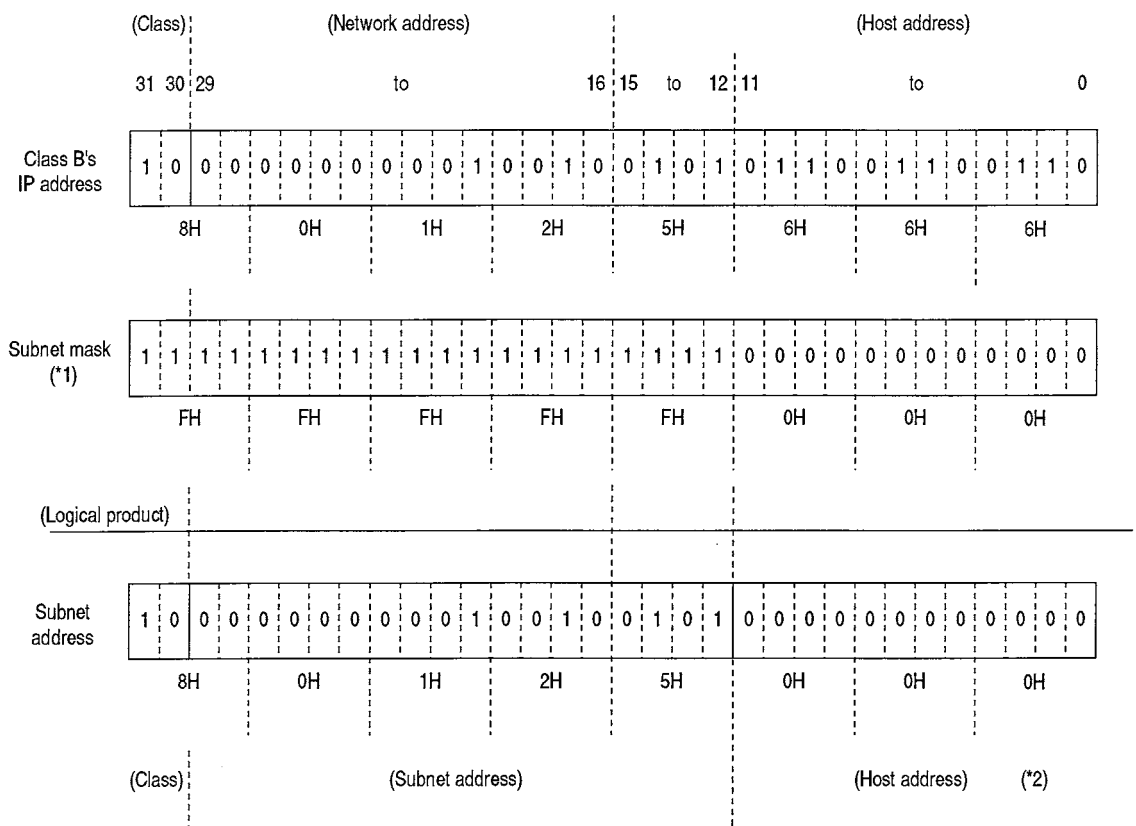

*1 The subnet mask is specified as a bit masked value where "1"s signify the network address and its extended portion and "0"s signify the host address.
 *2 001H to FFEH can be used as the host address.

11.2 Setting for the Subnet Mask

This section explains the subnet mask setting area which is used to divide the network to multiple virtual subnetworks to make management of one network easier.

The network manager (the person who plans the network or manages the IP addresses, etc.) needs to set the values for creating this area before initial processing.

Buffer Memory	
(Address)	Subnet mask setting area
200 to 201H (512 to 513)	Subnet mask field (2 words)
	Default value 0H (0)

1 Subnet mask field (Default value = 0H) Address 200H to 201H (512 to 513)

- (a) Set the subnet mask. (Setting range: C0000000H to FFFFFFFCH)
Consult the network administrator for the setting.
- (b) When not using the subnet mask, set any of the following table values according to the class.

Class	Mask Value
Class A	FF000000H
Class B	FFFF0000H
Class C	FFFFFF00H

- (c) The subnet mask field can be set in the GPP (Product after that shown in Item 4.8). When set using GPP, it is not necessary to set in the buffer memory from the PLC CPU.
- (d) If a subnet mask field value where all of the local station network address cannot be masked is specified, all of the network address will automatically be given masked values.

(Example) When the local station is Class B

Following is shown an example specification to the subnet mask field and the corresponding actual subnet mask's value. (Refer to Item 11.3 for the allocation of class B IP address)

Specified value to the subnet mask field	Actual subnet mask value
FF000000H	FFFF0000H
FF008000H	FFFF8000H
FFFF8000H	FFFF8000H

(To mask all network address, a subnet mask field of FFFF0000H or larger is required.)

- (e) When setting the subnet mask, perform the following settings as well as setting the subnet mask setting area:
 - Set to "Use router relay function" in the special function setting (address 4).
 - Set the router relay function (address 514 to 548).

11.3 Ethernet IP Address

This section explains in summary the Ethernet IP address and the classes, network address, and host address it contains.

1 Nodes connected to the Ethernet have both a fixed Ethernet address and a voluntary IP address for just that node.

Users do not need to be aware of the Ethernet address because it is handled by the ARP (Address Resolution Protocol).

The IP address shows the address on the network for each node connected to the Ethernet, so the user must remember this ID.

The IP address is divided into three classes of class A through class C to allow selection of the address system that is most suitable for the size of the network system.

A network manager (the person who plans the network, manages IP addresses, etc.) must set a 32-bit numerical value for each node following the standard IP address method used on a world wide scale.

2 The contents and role of each class, network address, and host address are as follows.

① Class A to Class C

Class A is for networks with many hosts, class C is for networks with few hosts, and class B is for networks of intermediate size. (Up to 254 hosts can be connected with class C.)

② Network address

This is used to identify the network to make it possible to handle multiple networks. Networks with different network address will be identified as separate networks.

③ Host address

This address is used to identify hosts on a network.

When using the subnet mask described in this chapter, the host address portion can be eliminated and an extension added to the network address.

* If the IP address is compared to a telephone number, the network address, host address, and port No. specified during data exchange would play the following roles.

Network address : long distance number, Host address : telephone number, Port No. : extension number

If the network address (long distance numbers) are the same then direct exchange is possible, but if they are different then exchange must be conducted by going through routers (telephone exchanges).

The function used for exchanging via routers (telephone exchanges) is the router relay function described in chapter 12.

(Example) When the local station QE71's IP address is class C (Refer to **3**)

(IP address top stage: hexadecimal expression, bottom stage: decimal expression)

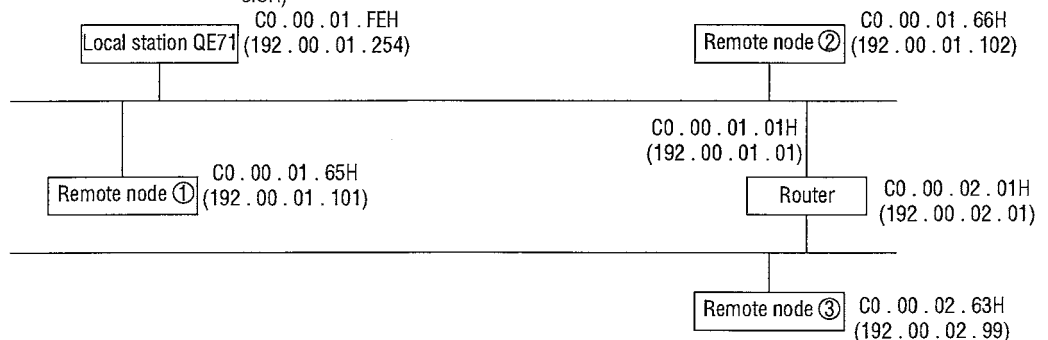

3 Shows the IP address allocation for each class.

When there are many nodes in the same network, then there must be many host address.

In addition, when there are few nodes in one net, but there are many networks, then there must be many network address.

(a) Class A, class B, and class C are identified by the first 2 bits of the IP address.

(b) In the class A IP address, the network address is allocated to the 7th bit and the host address is allocated to the 24th bit.

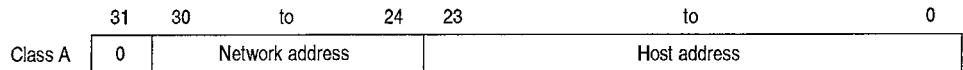

(c) In the class B IP address, the network address is allocated to the 14th bit and the host address is allocated to the 16th bit.

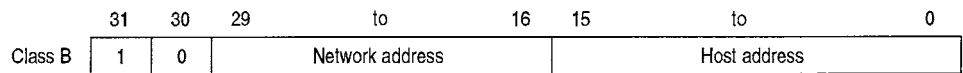

(d) In the class C IP address, the network address is allocated to the 21st bit and the host address is allocated to the 8th bit.

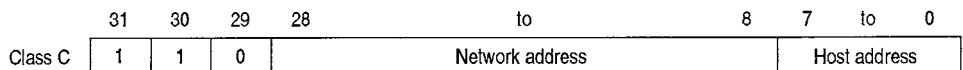

12. WHEN USING ROUTER RELAY FUNCTIONS

This section explains when a PLC CPU and a remote node are exchanging via a specified router relay.

12.1 Router Relay Functions

Normally, in an Ethernet that uses IP, exchange can only be conducted between the local station and remote nodes connected to the same Ethernet (have the same network address).

To exchange with a remote node on a different Ethernet (different network address), a router relay must be used.

This router relay function is for exchanging with remote nodes on different Ethernets (different network address).

Using this function makes it possible to exchange through routers and gateways using PLC CPU side TCP/IP Active open and UDP/IP transmission.

(The router relay function does not operate as a router.)

Exchange using the QE71's router relay function is conducted when the buffer memory is given the following settings by the user initial processing.

- Special function setting: sets "using router relay function"
- Router relay parameter settings: set a default router and a maximum of 8 voluntary routers

When exchanging data, the QE71 conducts router relay exchange with remote Ethernet using the following method when the partner station subnet address in the message differs from the local station subnet address.

- ① The corresponding router relays the exchange when there is a partner station subnet address in the user set router relay parameter.
- ② Relay exchange is conducted using the default router when there is no partner station subnet address in the user set router relay parameter.

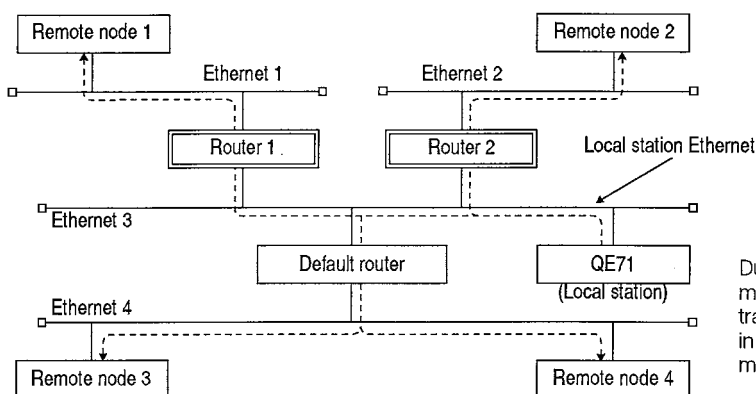

During transmission, the QE71 does not transmit directly to the partner station, but instead transmits the data once to the router specified in the router relay parameter. The router transmits the received data to the partner station.

Point

- (1) It is not necessary to use the router relay function when the QE71 is exchanging with a partner remote node using a router relay in Passive open (TCP/IP).
In this case, exchange can be done even if the router relay function is not used.
- (2) The router relay function is not required in systems that use Proxy routers.

12.2 Exchangeable Functions and Settable Range Using Router Relay Functions

This section explains the data exchange functions and settable range used to exchange data with remote Ethernets using router relay functions.

1 Exchangeable functions

When conducting the following data exchange, exchange with remote Ethernets can be done using the router relay function.

- Fixed buffer exchange (possible for either with procedure and without procedure)
- Random access buffer exchange
- Reading/writing data in the PLC CPU

2 Settable range

This makes it possible to exchange with remote nodes connected to Ethernet within the range accessible via the router. There is one default router and 8 voluntary routers set in the QE71 through which exchange can be conducted.

12.3 Summary of Router Relay Processing

This section gives an overview of the router relay processing conducted by the QE71 when data is transmitted to remote nodes on remote Ethernets via routers.

The QE71 determines the transmission destination of the data at the time data is transmitted using the following procedure.

1 Checks whether there is a setting that uses the router relay function.

If the setting does not use the router relay function, exchange is done directly with the partner remote node.

2 Checks whether the partner remote node is connected to the same Ethernet as the local station by using the following two formulas. (Subnet address check)

If they are the same, then it is determined that it is the same Ethernet and exchange is done directly with the partner remote node. If they are different, it is judged that it is a remote Ethernet, and exchange to the partner node is conducted via a router.

(Formula-1) Partner station IP address and subnet mask field logical product

(Formula-2) Local station IP address and subnet mask field logical product

3 When it is recognized that the partner remote node is connected to a remote Ethernet, exchange with the partner remote node is conducted via a router.

(a) When the partner remote node is the same class as the local station

The above (formula-1) and the valid subnet addresses 1 to 8 in the router relay parameter are compared.

If the settings are the same, exchange is conducted to the router supporting the router IP address.

If the settings are different, exchange is conducted to the default router.

(b) When the partner remote node and the local station are different classes

The partner remote node's network address and the valid subnet addresses 1 to 8 in the router relay parameter are compared. If they are the same, then exchange is conducted to the router that supports the router IP address. If they are different, then exchange is conducted to the default router.

12.4 Setting for Using Router Relay Functions

This section explains about the parameter setting area used to conduct exchange with remote nodes using the router relay function.

The network manager (the person who plans a network, manages IP addresses, etc.) sets the values for the area before initial processing. (*1)

		Buffer Memory		
(Address)		Router relay parameter (36 words)		Default value
202	to 203H (514 to 515)	Default router IP address (2 words)		0H (0)
	204H (516)	Number of registered routers (1 word)		0H (0)
205	to 206H (517 to 518)	Router 1 setting	Subnet address 1 (2 words)	0H (0)
207	to 208H (519 to 520)		Router IP address 1 (2 words)	0H (0)
209	to 20AH (521 to 522)	Router 2 setting	Subnet address 2 (2 words)	0H (0)
20B	to 20CH (523 to 524)		Router IP address 2 (2 words)	0H (0)
20D	to 20EH (525 to 526)	Router 3 setting	Subnet address 3 (2 words)	0H (0)
20F	to 210H (527 to 528)		Router IP address 3 (2 words)	0H (0)
211	to 212H (529 to 530)	Router 4 setting	Subnet address 4 (2 words)	0H (0)
213	to 214H (531 to 532)		Router IP address 4 (2 words)	0H (0)
215	to 216H (533 to 534)	Router 5 setting	Subnet address 5 (2 words)	0H (0)
217	to 218H (535 to 536)		Router IP address 5 (2 words)	0H (0)
219	to 21AH (537 to 538)	Router 6 setting	Subnet address 6 (2 words)	0H (0)
21B	to 21CH (539 to 540)		Router IP address 6 (2 words)	0H (0)
21D	to 21EH (541 to 542)	Router 7 setting	Subnet address 7 (2 words)	0H (0)
21F	to 220H (543 to 544)		Router IP address 7 (2 words)	0H (0)
221	to 222H (545 to 546)	Router 8 setting	Subnet address 8 (2 words)	0H (0)
223	to 224H (547 to 548)		Router IP address 8 (2 words)	0H (0)
	225H (549)	System area (Usage not possible :1 word)		—

1

Default router IP address (Default value = 0H) Address 1C2H to 1C3H (450 to 451)

Set the IP address of the router (default router) via which communication with a remote node on a remote Ethernet is made when the router is not the one specified with the subnet address (refer to section **3**).

Set the value that will satisfy the following conditions.

- Condition 1: The IP address class is any of A, B and C.
- Condition 2: The subnet address of the default router is the same as that of the local station QE71.
- Condition 3: Bits of the host address should not be all "0" or all "1".

POINT

If the corresponding subnet address (refer to **3** in this section) does not exist when the connection is opened or data communication is made, communication is made via the default router.

2 Number of registered routers (Default value = 0H) Address 204H (516)

- (a) Sets the number of corresponding routers (number of valid settings) using the following subnet address n and router IP address n when conducting exchange with a remote node on a remote Ethernet via anything other than the default router.
- (b) Specifies the setting value to 0 to 8. (If a value higher than 9 is set, it will be seemed as 8.)
- (c) Sets the specified numbers portion of the subnet address n and router IP address n in the following area.

3 Subnet address n (Default value = 0H) Address 205H....(517...)

- (a) Set the network address (*1) or subnet address (*2) of the remote node when the QE71 communicates with the target device on another Ethernet via other than the default router. Set the value that satisfies the following conditions.
 - Condition 1: The IP address class is any of A, B and C.
 - Condition 2: The host address bits are all "0".

*1 If the class (network address) of the local station differs from that of the remote node, set the network address of the remote node.

*2 If the class (network address) of the local station is the same as that of the remote node, set the sub-net address of the remote node.
- (b) Subnet address setting examples

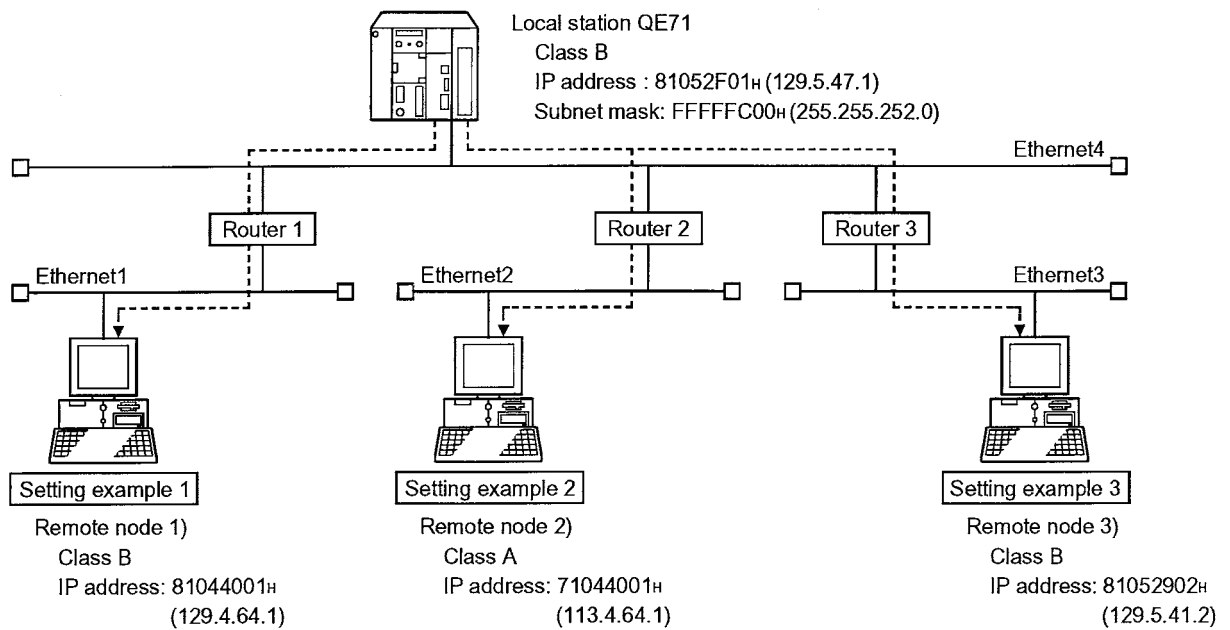

(Setting example 1) When the network addresses of the local station QE71 and remote node differ

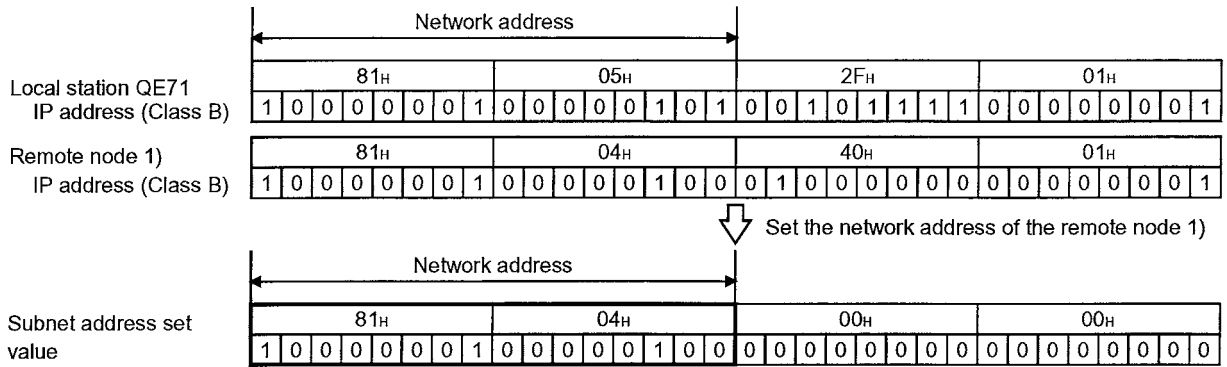

(Setting example 2) When the classes of the local station QE71 and remote node differ

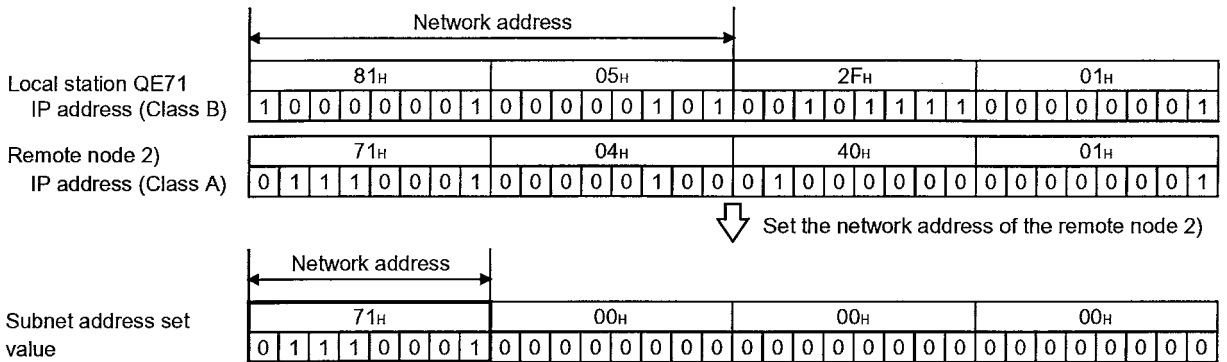

(Setting example 3) When the network addresses of the local station QE71 and remote node are the same

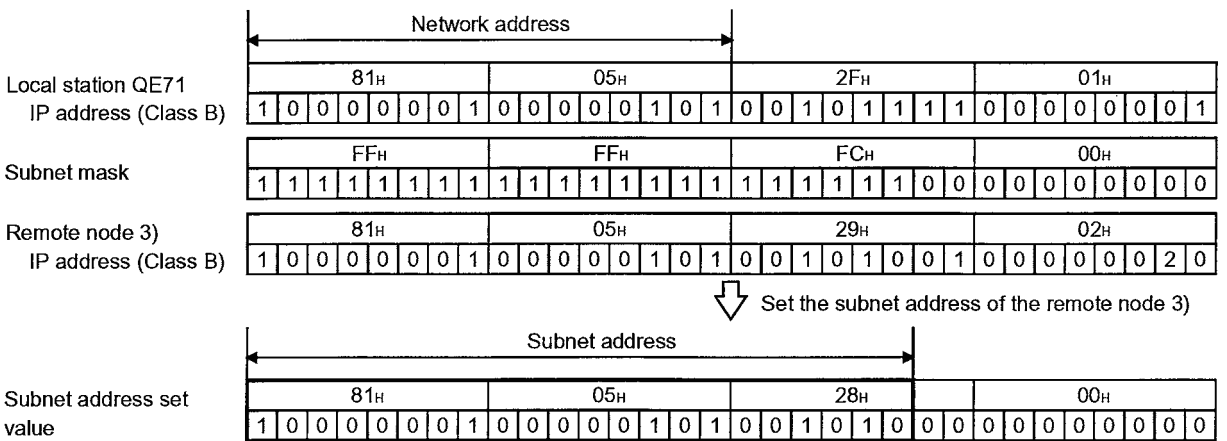

4**Router IP address n (Default value = 0H)Address 207H....(519...)**

Set the IP address of the router (default router) to be used when the QE71 communicates with the remote node on another Ethernet via other than the router specified in the router information (refer to (4) below).

Set the value that satisfies the following conditions.

- Condition 1: The IP address class is any of A, B and C.
- Condition 2: The sub-net address of the default router is the same as that of the local station QE71.
- Condition 3: The host address bits are not all "0" or all "1".

*1 Settings to the router relay parameter setting area are to be conducted as follows using the exchange condition setting switch (SW3: automatic start up mode setting) ON/OFF on the front of the QE71.

- SW3 = when OFF : Set before the initial request signal (Y19) turn on.
- SW3 = when ON : Set in advance in the router relay parameter setting area and register in the QE71's EEPROM as described in Item 4.9. (Set before turning the power on)

The router relay parameter can be set in the GPP (Product after that shown in Item 4.8). When set using GPP, it is not necessary to set in the buffer memory from the PLC CPU.

Point

When using the router relay function set the following settings in addition to settings in the router relay parameter setting area.

- * Set "using router relay function" (address 4H(4)) in the initial processing parameter setting area's special function setting area.

13. WHEN USING FILE TRANSFER FUNCTIONS (FTP SERVER)

Files in the local QnACPU to which the QE71 is installed can be read and written from remote nodes using the QE71 file transfer function.

In this chapter, how to use the QE71 FTP function from remote nodes (personal computer, workstations, etc.) is described.

13.1 File Transfer Functions

The file transfer functions (abbreviated as FTP server from here on) of the QE71, to perform read/write to the files in the QnACPU from a remote node side is described.

13.1.1 File Transfer Functions

The QE71 supports the FTP (File Transfer Protocol) server function, which uses the protocol to transfer files between computers. It functions as the file server for the files in the QnACPU. The FTP commands are used to specify data transfers in file units.

The remote nodes with the FTP client functions, can easily access (read/write) the user-created files in the QnACPU directly using the QE71 FTP server functions.

- Reading a file from the QnACPU (download)
 - Read for storing the QnACPU files in the remote node.
- Writing a file to the QnACPU (upload)
 - Write for storing the file in the remote node to the QnACPU.
- Scanning QnACPU files
 - Scan to check the files registered in the QnACPU, from the remote node.

With these QE71 FTP server functions, all user files in the QnACPU (parameters, sequence programs, and data files) can be accessed using the FTP commands from the remote node.

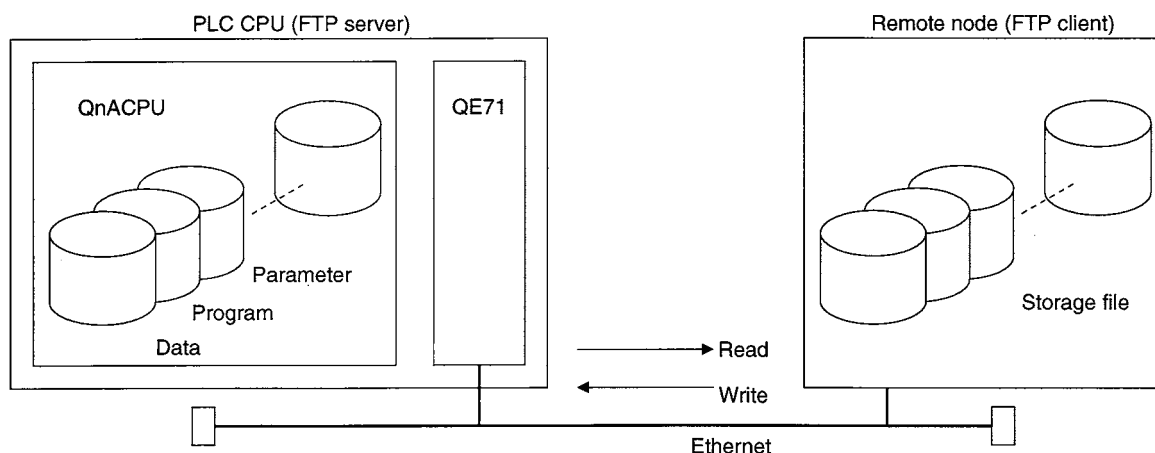

Remarks

A remote node can perform QnACPU file management using the QE71 FTP server functions.

The QnACPU files read by QE71 can be stored in the remote node, and can be downloaded to the QnACPU as necessary.

Furthermore, if the remote node which serves as the FTP client has the product after SW2□-GPPQ installed, the following file operations can be performed from the remote node. Therefore, remote operations to the QnACPU files can be performed via Ethernet.

These functions are applicable only for the QnACPU files which allow user operations from GPP.

1 Transferring files created using GPP

The procedure to write the file created using remote GPPQ to the QnACPU is described:

- ① Perform the write processing to the editable program file created using the GPPQ from the IC memory card menu in the GPPQ file maintenance mode, then store in the disk. (*1)
(FTP transferable the QnACPU executable program file is created.)
- ② Transfer the QnACPU executable program file stored in the disk by the write processing to QE71 using FTP function and register it to the QnACPU.

2 Editing QnACPU file read via QE71

The procedure to edit a file read from the QnACPU using the remote node GPPQ is described:

- ① Perform read processing of the QnACPU executable program file read from the QnACPU using the FTP function from the IC memory card menu in the GPPQ file maintenance mode. (*1)
(The editable program file that allows user edit using GPPQ is created.)
- ② Perform read edit (add, modify or delete) the editable program file stored in the disk by the read processing using the GPPQ's new file read function, etc.

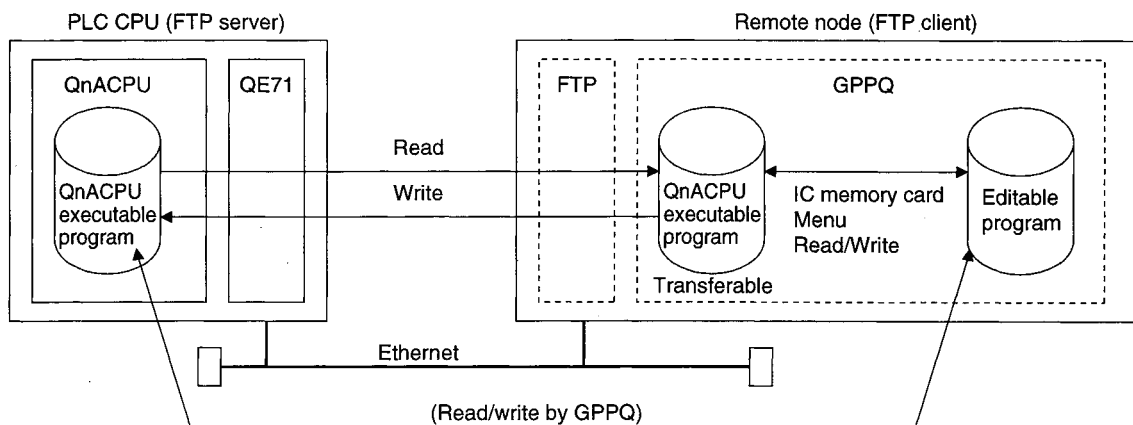

*1 The remote node must store the QnACPU executable program file to be used for FTP in the hard disk or floppy disk.

When performing operations from the IC memory card menu using GPPQ, specify the hard disk or floppy disk drive in the drive/path column for the FTP QnACPU executable program file storage destination.

Refer to the GPPQ Operating Manual for the specification method and IC memory card menu operations.

13.1.2 FTP Server Support Functions of QE71

The FTP commands supported by QE71 when it serves as the FTP server by the QE71 are indicated below:

The “write enable” and “write prohibit” in the chart indicate the setting in the exchange condition setting switch (SW:7 CPU exchange timing setting) for the QE71 main module. (Write enable: SW7=ON, write prohibit: SW7=OFF)

1 Client-side user interface command list (supported by QE71)

Command	Function	PLC CPU status			Remark
		During STOP	During RUN		
			Write enable setting	Write prohibit setting	
binary	Notify to transfer without converting file	○	○	○	—
bye	Shut down and end the connection with FTP server	○	○	○	
close	Shut down the line with FTP server	○	○	○	
delete	Delete QnACPU file	○	○(*1)	×	
dir	Display QnACPU file information	○	○	○	
get	Read file from QnACPU	○	○	○	
ls	Display QnACPU file names	○	○	○	
mdelete	Delete QnACPU file	○	○(*1)	×	
mdir	Store QnACPU file information to file	○	○	○	
mget	Read file from QnACPU	○	○	○	
mls	Store QnACPU file names to a file	○	○	○	
mput	Write file to QnACPU	○	○	×	
open	Connect with FTP server	○	○	○	
put	Write file to QnACPU	○	○	×	
pwd	Display QnACPU current directory	○	○	○	
quit	Shut down and end the connection with FTP server	○	○	○	
quote	Send FTP server sub-command	○	○	○	
rename	Change QnACPU file name	○	○	×	—
user	Enter user name and password for QE71	○	○	○	

*1 The parameter file and the sequence program file cannot be deleted during RUN.

*2 The list of QE71-dedicated commands used along with the quote command is described on the next page.

When executing the commands from the FTP client, attach the command after the "quote" command.

(Example) When executing the stop command.

Enter the following in the command prompt : **quote stop <ret>**

Point

QE71 dedicated command	Function	PLC CPU status			Remark
		During STOP	During RUN		
			Write enable setting	Write prohibit setting	
status	Display QnACPU operation information	○	○	○	QE71-FTP server dedicated commands
stop	Set QnACPU to STOP state	○	○	○	
run	Set QnACPU to RUN state	○	○	○	
change	Display/change QnACPU file attributes	○	○	×	
keyword-set	Set/display/clear QnACPU file access keywords	○	○	○	

Some of the commands may not operate as described in this manual depending on the client-side FTP application.

Refer to the manual for the FTP client side (remote node), and confirm the functions and operation methods as well.

13.2 File Transferable Range

The file transferable range from the remote node (QnACPU with QE71 installed station) is described.

The file transfer operation from the remote node using the QE71 FTP server function can be performed from any remote nodes with QE71 on the Ethernet.

When the router relay function shown in Chapter 12 is used, the remote nodes on the Ethernet connected via the specified router can perform FTP functions.

File transfers can be performed from the following remote nodes with the * symbol.

File transfers cannot be performed from the remote nodes on the Ethernet (3) which is connected via MELSECNET/10.

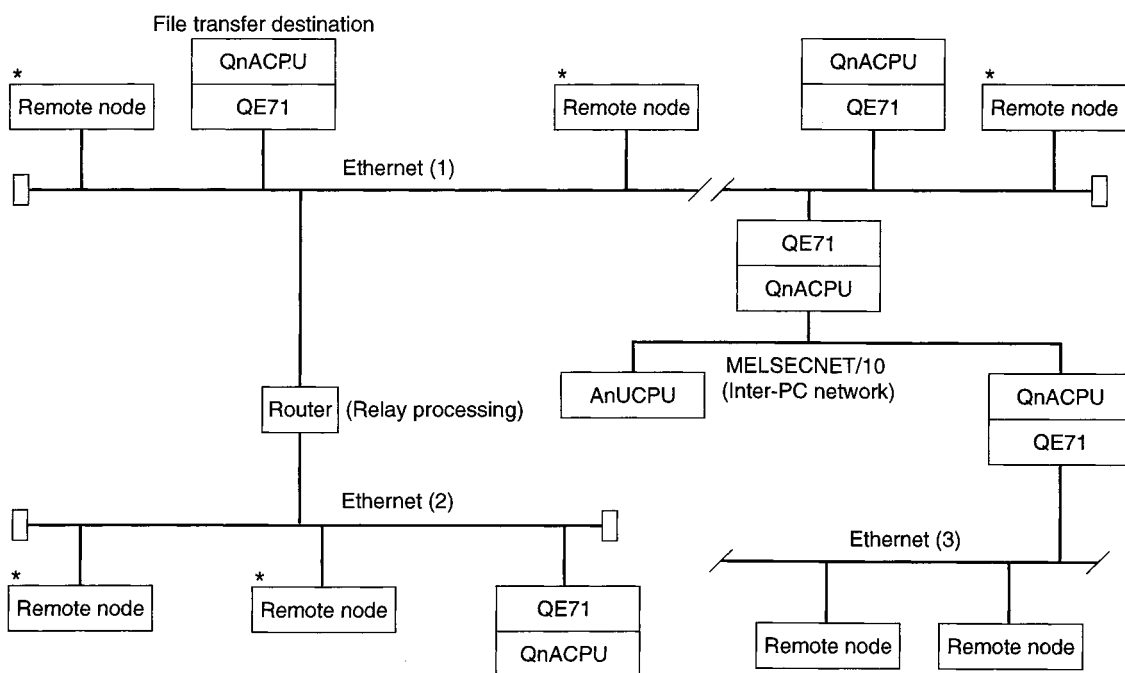

13.3 Setting for File Transfer

The FTP parameter setting area used to perform file transfers from remote nodes using QE71 FTP server functions is described.

Set this area before initializing the QE71. (*1)

		Buffer Memory		
(Address)		FTP parameter setting area (16 words)		Default value
3B0 to 3B5H (944 to 949)	FTP log in name (6 words)	(6 words)		4A41H(JA)
				3137H(17)
				4551H(EQ)
				3137H(17)
				0000H()
3B6 to 3B9H (950 to 953)	Password	(4 words)		4A41H(JA)
				3137H(17)
				4551H(EQ)
				3137H(17)
3BAH (954)	Command input monitoring timer	(1 word)	708H (1800)	
3BBH (955)	ACPU monitoring timer	(1 word)	AH (10)	
3BC to 3BFH (956 to 959)	System area	(Unusable, 4 words)	—	

(1) FTP log in name (Default value = "AJ71QE71")..... Address 3B0 to 3B5H (944 to 949)

Password (Default value = "AJ71QE71") Address 3B6 to 3B9H (950 to 953)

- (a) To use the QE71 FTP server function, a log in name and password to be sent during file transfer request (log in) to the QE71 from the remote node must be set.
- (b) The default values for the FTP log in name and password are both "AJ71QE71".
- (c) When changing the FTP log in name and password, specify using ASCII code alphabets (upper and lower case), numbers, - (hyphen), and _ (underscore).
 - FTP log in name : Max. 12 characters (Max. 12 single-byte characters)
 - Password : Max. 8 characters (Max. 8 single-byte characters)

If the log in name or password do not reach the maximum characters (12 characters and 8 characters), the rest are specified as NULL (code 00H).

* Upper and lower case letters are identified as separate letters.

(d) If a character that is not allowed for use is included in the changed FTP log in name, "AJ71QE71" will be used for the log in name.

If a character that is not allowed for use is included in the changed password, password will be used for "AJ71QE71".

(e) The specified FTP log in name and password set are used to check the log in name and password received from a remote node (FTP client).

(Example)

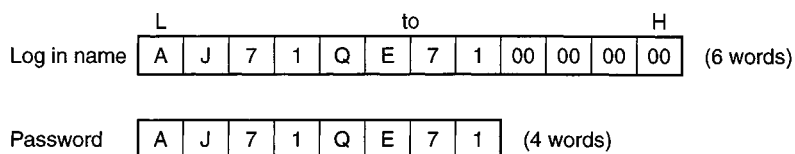

- (2) Command input monitoring timer value (Default value = 708H (1800), setting time = setting value x 500 ms) Address 3BAH (954)
- (a) The monitoring time when the QE71 as the FTP server monitors the command input time from the FTP client.
 - (b) This default value is recommended for this timer value.
When changing the setting value, determine the command input monitoring timer value after consulting with the maintenance personnel of the partner equipment or the system.
 - (c) The setting value is specified within the range 1H to 7FFFH. (15 minutes at default 708H (1800))
When 0H is specified, the default 708H (1800) is set as the command input monitoring timer value. (The user-specified value remains in the buffer memory.)
 - (d) If there is no command input within the command input monitoring timer value after a FTP client logged in, the FTP connection is shut down.
When restarting the file transfer, perform the log in operation once again.
- (3) ACPU monitoring timer value (Default value = AH (10), setting time = setting value x 500 ms) Address 3BBH (955)
- (a) Sets the monitoring time for the QE71 to monitor the local QnACPU operation when the QE71 is operating as the FTP server.
 - (b) The default value is recommended for this timer value.
When changing the setting value, determine the command ACPU monitoring timer value after consulting with the maintenance personnel of the partner equipment or the system.
 - (c) The setting value is specified within the range 1H to 7FFFH. (15 seconds at default AH (10))
When 0H is specified, the default AH (10) is set as the command input monitoring timer value.
(The user-specified value remains in the buffer memory.)
 - (d) When the ACPU monitor detects an error after a FTP client logged in, the FTP connection is shut down.
When restarting the file transfer, check the normal operation of the local QnACPU, then perform the log in operation again.
- *1 The FTP parameter can be set in the GPP (Product after that shown in Item 4.8) . When set using GPP, it is not necessary to set in the buffer memory from the PLC CPU.

Point

When using the QE71 FTP server functions, the special function setting in the initial processing parameters described in Item 5.2.2 must be set to "FTP" as well as performing the above FTP parameter settings.

13.4 File Transfer Procedure

The procedures and required processes when transferring files from remote nodes using the QE71 FTP server functions are described.

13.4.1 Procedures and Required Processes at the QE71 (FTP Server)

The procedures and required processes for the QE71 to transfer files from remote nodes are described.

1 QE71 startup

The following are performed when continuing the file transfer on the QE71 side even if the QnACPU is at a STOP state.

- Turn on the exchange condition setting switch (SW3:automatic startup mode setting) to startup the QE71. (Refer to Item 4.4.)
- After starting up the QE71, turn on the bit 15 in the exchange instruction area during STOP (enable exchange when the initial request signal is off) before initial processing. (Refer to Item 16.2.)

2 QE71 initial processing

- ① When changing the default value of the FTP parameters shown in Item 13.3, it specifies "FTP" by the special function setting for the initial processing parameters shown in Item 5.2.2.
- ② The QE71 initial processing is performed as described in Item 5.2.
- ③ When the initial processing is completed successfully, the QE71 FTP server function can be used from the remote node.

3 File transfer from remote node

- ① Log in to the QE71 as described in Item 13.4.2, and perform file transfer.
- ② By logging in to the QE71, bit 7 of the LED ON status storage area (address C8H) in the buffer memory turns on.
(Bit 7: ON (1) when open, OFF (0) when bye)

4 QE71 end processing

When ending all exchange for file transfers and open processed communication line by the user, perform the end processing for the QE71 by turning off the initial request signal.

- * File transfers can be performed from remote nodes until the end processing is performed on the QE71. When the end processing is performed at QE71, the QE71 forces a log out (closes the file transfer line) to each remote node even though already logged in.

13.4.2 Procedures and Required Processes at the Remote Node (FTP Client)

The procedures and required processes on the remote node side when using the QE71 FTP server functions are described. In the description, the necessary FTP operation command and the input format are described for each operation.

(<ret> indicates pressing one of the **CR**, **Enter**, or **Return** keys.)

1 Confirming the QE71 initial processing

Check that the QE71 initial processing is ended successfully with the QE71 display LED/I/O signals.

- Display LED : The "RDY" LED on the QE71 front panel is flashing
- I/O signal : Initialization normal end signal (X19) is turned on.

2 Log in to QE71

When the QE71 initial processing is ended successfully, log in to the QE71 is performed.

(Bit 7 of the LED ON status storage area (address C8H) in the buffer memory turns on after logging into the QE71.)

- ① FTP startup (ftp <ret>)
- ② Connect to FTP server (open FTP server IP address <ret>)
- ③ Specify log in name (log in name (default value: AJ71QE71) <ret>)
- ④ Specify password (password (default value: AJ71QE71) <ret>)

* The log in name and password set in the FTP parameter setting area in the buffer memory during the QE71 initial processing are used.

When the QE71 (FTP server) receives the log in name and password from the remote node (FTP client), it verifies them by comparing with the FTP log in name and password stored in the buffer memory FTP parameter setting area.

When the log in name and password match, file transfers with the QE71 is permitted, and if log in not, file transfer is not permitted.

3 FTP operations

- ① Notify the file is transferred without conversion (binary <ret>)
- ② When a key word is registered in the QnACPU drive for the file transfer, the key word is set in the QE71. (quote keyword-set keyword <ret>)
- ③ Perform file transfer operations using the FTP command described in Item 13.6.

As an operation example, the procedure to write/read the sequence program file to the QnACPU is described on the following page.

Point

Perform a write to the parameter file currently used by the QnACPU and to the sequence program file in execution in the built-in RAM after setting the QnACPU to the stop state.

4 Shutting down the connection with the FTP server

The connection with the FTP server is shut down, and ends each FTP operation. (bye <ret>)
(Bit 7 of the LED ON status storage area (address C8H) in the buffer memory turns off when the connection is shut down.)

File transfer operation procedure example

The following two procedures performed between log in and log out are described as FTP operation examples:

- Read the sequence program file from the QnACPU
- Write the sequence program file to the QnACPU

① The procedure to read the sequence program file from the QnACPU (FTP client ← FTP server)

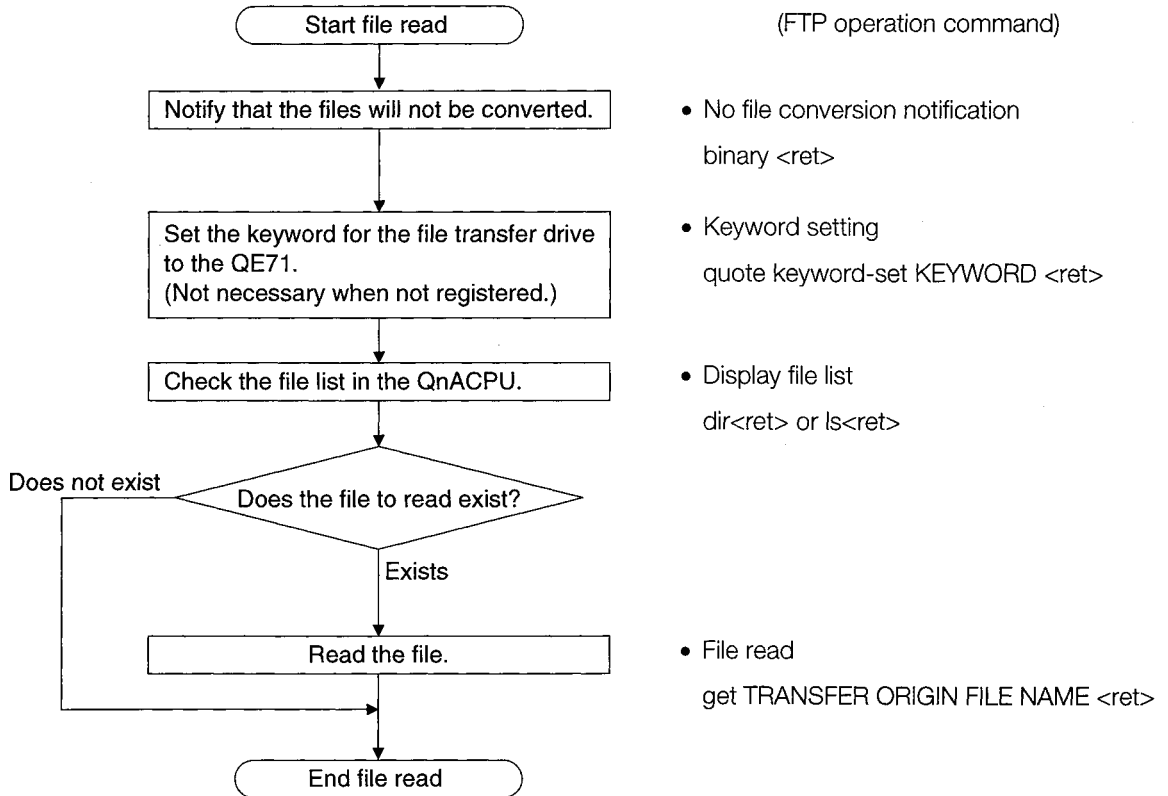

② Procedure to write the sequence program file to QnACPU (FTP client → FTP server)

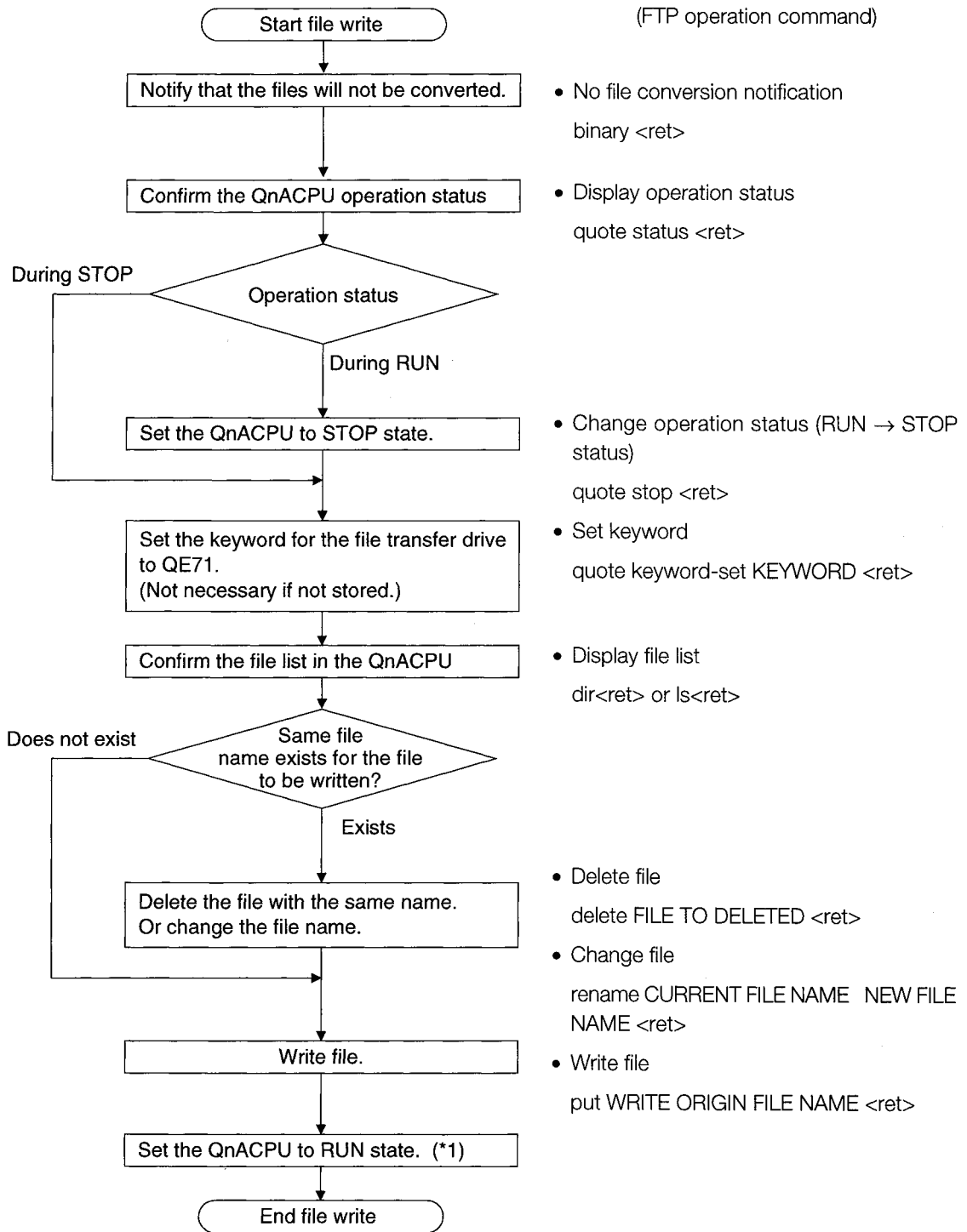

*1 The QnACPU must be set to STOP → RUN → STOP → RUN.

When restarting the QnACPU operation after writing a file, it is recommended to set QnACPU to RUN with the key switch.

The QnACPU can change its status from STOP → RUN from the FTP command, but caution must be taken to the PLC system operations.

13.5 Precautions When Using the File Transfer Functions

The precautions when using the QE71 FTP server functions are described.

1

Precautions when designing a system which uses file transfer functions

(a) For the system

When performing file transfers with the system in operation or controlling the status of the PLC, design the system (such as configuring an interlocking circuit in the sequence program) so that the safety of the overall system is always maintained.

(b) For remote nodes

Some of the FTP operation commands on the FTP client (remote node) supported by the QE71 as a FTP server may not operate as described in this manual, depending on the client side FTP application.

Refer to the manual on the FTP client (remote node), and confirm the functions and operation methods.

(c) For the QnACPU

① Only files that can be created/generated by the user with GPP can be transferred. (Refer to Item 13.6.2.)

② File transfers can only be performed to the local station QnACPU with the QE71 installed.

③ When file read/write is performed by the file transfer functions while QnACPU is running, the QnACPU's sequence scan time may take longer than when using QE71's other functions, and the file read/write take a few minutes or longer depending on the file size or sequence scan.

The file read/write processing time may take even longer depending on various conditions such as the Ethernet line load (line traffic), number of connections used at the same time (exchange processing which uses another connection), and the system configuration.

It is recommended to perform file read/write while the QnACPU is at the stop state.

2

Precautions when starting up the QE71

① Start the file transfer by performing one of the following so that the file transfer can be continued even if the QnACPU is switched to the stop state.

- Turn on the exchange condition setting switch (SW3: automatic startup mode setting) to startup the QE71. (Refer to Item 4.4.)

- Turn on the bit 15 of the exchange instruction area during STOP (exchange is enabled while the initial request signal is off). (Refer to Item 16.2.)

② When the QnACPU is write-protected (protect switch is on), file transfers which perform write (attribute change, file write, etc.) cannot be performed.

3**Precautions common to any usage of the file transfer functions**

(a) For GPP

The files used for the file transfer cannot be handled directly with GPP. Therefore, the following are not possible:

- Writing the file created by the remote node GPP to the QnACPU via file transfer.
- Editing a file read to the remote node via file transfer from the QnACPU using the GPP.

File transfer and edit are enabled by performing the data conversion using the IC memory card menu function in the GPPQ beforehand. (Refer to Item 13.1.1 and the GPPQ manual.)

(b) For remote nodes

If a timeout error occurs during file transfer using the FTP function, the line for the FTP function will be closed regardless of the setting of the exchange condition setting switch (SW1: line processing selection during TCP timeout error) on the QE71's main module.

When restarting the file transfer, perform the log-in operation to the QE71 from the FTP client again.

(c) For the QnACPU

- ① When the keyword is registered to the file transfer drive, send the same keyword (set in QE71) using the FTP operation command "quote keyword-set" after logging in.

* If the keyword is registered, the same keyword must be specified to access that drive.

The keyword is a text string (max. 6 characters) specified by the user to the drive, and it enables/prohibits access to the drive.

- ② The QnACPU files for file transfer must be in the root directory of each disk.
- ③ While accessing a QnACPU file using the FTP function, do not operate the QnACPU key switches, change the operating status (such as RUN → STOP and STOP → RUN) from another GPP, turn off/reset the power, or install/remove the memory card.
If any of these operations is performed, the QnACPU files will corrupt and the QnACPU may not be able to start again.

- ④ Do not perform any file operations (read/write/change file information) from another GPP, etc. when the FTP function is in operation.

When file operations are performed from another GPP, etc. while the FTP function is in operation, the FTP function may abnormally end.

4**Precaution when logging in to the QE71 (FTP server)**

Only one remote node (FTP client) can log in to the QE71 at a time.

5 Precautions when writing a file

- ① Operation to overwrite an existing file cannot be performed.
Either delete corresponding file using the file delete command (delete, mdelete), or change the file name using rename command before the file is written.
- ② The sequence program file specified in the parameter file currently used for the QnACPU operation cannot be written.
Set the QnACPU to the stop state, then write in the file.
- ③ File transmission (attributes change, file write, etc.) for file write can only be conducted for the QnACPU built-in RAM or the memory card RAM area.
- ④ Check the number of files that can be registered to the drive for the files to be stored.
File write cannot be performed to a drive where the number of files has already reached the allowed number of registered files.
* The files are stored in the specified drive's cluster size units.
- ⑤ Any file which fits in the size of the continuous unused clusters in the specified drive memory can be written.
When writing a file larger than the size of the continuous unused clusters, set the unused continuous clusters to be more than the necessary size by reorganizing the drive memory with the function shown in Item 6.5 or with GPP.
- ⑥ When restarting the QnACPU operation after writing a file, it is recommended to set to the run state using the QnACPU key switch.
The QnACPU can be switched from STOP to RUN using the FTP command, but sufficient caution must be taken for the PLC system operations.
- ⑦ When writing files, the QE71 creates temporary work files (FTP_lxxx.TMP) in the QnACPU.
The temporary files are automatically created in the specified drive during the file write (put or mput), and the file name is changed to the specified file name after the operation is completed.
The "xxx" in the temporary file name "FTP_lxxx.TMP" is the upper three digits of the four digits representing the QE71's I/O signals from the QnACPU.
* The temporary file is automatically deleted when the file write is successfully completed, line is shut down during transfer, or a file capacity error occurs with the QnACPU.
- ⑧ The temporary work file may remain in the specified drive when the QnACPU power is disconnected or reset during the file write.
When the temporary file remains in the drive, delete the file using the FTP command.
The GPP file operations may be disabled if the temporary file exists.

6 Precautions when deleting files

- ① When determining the timing to delete files, consider the system operation as a whole including the functions of QnACPU and related equipments.
- ② The parameter file and sequence file can not be deleted during the QnACPU is performing "RUN".
Delete these files after setting the QnACPU to the stop state.
- ③ Files with read-only attribute and files that are locked from another equipment or function cannot be deleted.
* The file attributes can be changed using the FTP operation command, "quote change."
- ④ File deletion can only be conducted for the QnACPU built-in RAM or memory card RAM area.

13.6 FTP Commands

The FTP operation commands on the FTP client side (remote nodes) supported by the QE71 FTP server are described.

13.6.1 File Specification Method

The file specification method in the FTP operation command from the FTP client side is described.

Specification descriptions

- ' ' : The area within the ' ' indicates one argument.
- [] : The area with the brackets [] indicates that it is optional.

1 Keyword

If a keyword is registered for the QnACPU drive, the keyword must be set to the QE71 before the file transfer.

Refer to the "quote keyword-set" command in Item 13.6.4.

2 File path

- (a) The QnACPU specifies the file by differentiating the drive name and file name.
- (b) When specifying a file in the QnACPU using the FTP functions, specify the file in the following manner:

[Specification format] ['drive name': \] 'file name' . 'extension'

[Specification example] 0 : ¥ MAINSEQ1. QPG

- [Specification details] ① Drive name
- The drive number of the corresponding disk for the file transfer is specified.
 - The QnACPU disks and the corresponding drive names are shown below.
 - If the drive name is omitted, "F" is used as default.

Drive name	Corresponding disk	Remark
0	Built-in RAM	Built-in memory
1	RAM area of the memory card A	IC memory card
2	ROM area of the memory card A	
3	RAM area of the memory card B	
4	ROM area of the memory card B	
F	Drive which stores the parameter file currently used	Disk specified by the QnACPU DIP switch.

② File name, extension

- The corresponding file for the file transfer is specified.
- The file name must be specified according to the GPP file name rules. Alphabets (upper case), numbers, symbols, kana letters, and Japanese characters (shift JIS kanji code) can be used.

File name: Max. 8 characters (when using single-byte characters)

Extension: Max. 3 characters (when using single-byte characters)

- For the extension (identifier), the name fixed by the QnACPU must be used.

The corresponding file extension is specified as seen in Item 13.6.2.

- Refer to the GPP Operating Manual for the details about the file names and extensions.
- When using a FTP operation command which can specify multiple files, the files (file names and extensions) are specified using wild card symbols, * and ?.

* : Files containing the characters before "*" and any set of characters (including none) replacing the "*" are specified.

(Example. 1) When specifying all files with the "QPG" extension

*.QPG

(Example. 2) When specifying file names which start with "MAIN" and the extension is "QPG":

MAIN*.QPG

? : The files containing the text string specified (including none), replacing ? with any character including none. ("?" can be used multiple times.)

(Example. 1) The letter after "MAIN" is any character and the extension is "QPG":

MAIN?SEQ.QPG

(Example. 2) To specify all files whose extension start with ".QP":

*.QP?

(Example. 3) To specify all files whose extension start with "Q":

*.Q??

Point

- (1) In the description of the FTP operation commands, the file name indicates both the file name and extension.
- (2) When the file name includes a Japanese character or a double-byte code character, the file name may not be recognized because of the difference in the kanji code types in FTP server and client side. Therefore, it is recommended to use the following method to treat the file name from the remote node.
 - Use the ASCII code characters (upper case for the alphabet letters) for the file to be written to the FTP server.
 - Do not change the file name for the file read from the QnACPU.
- (3) There are no sub-directories in the QnACPU disks.
Each file is stored in the root directory.

3**Attributes**

The following is specified when changing the attributes of the file stored in the QnACPU drive to be transferred:

“r” (read-only) ↔ “w” (read/write enabled)

Refer to the “quote change” command in Item 13.6.4

13.6.2 QnACPU User File List

The user-created files (files that are/can be created by the user with GPPQ) that can be specified for file transfer are described below:

Point

Type	File type	File identifier	Drive that can store the file (Refer to Item 13.6.1.)					Remark
			0	1	2	3	4	
For programs	Parameters	QPA	○	○	○	○	○	1 file/drive
	Sequence program	QPG	○	○	○	○	○	—
	SFC program							
For devices	Device comments	QCD	○	○	○	○	○	Max. 124 files
	Device initial values	QDI	○	○	○	○	○	
	File registers	QDR	×	○	○	○	○	
	Simulation data	QDS	×	○	×	○	×	—
	Local device	QDL	×	○	×	○	×	1 file/CPU
For debugging	Sampling trace data	QTS	×	○	×	○	×	—
	Status latch data	QTL						
	Program trace data	QTP						
	SFC trace data	QTR						
For diagnosis	Error log data	QFD	×	○	×	○	×	—

○ : Can be stored × : Cannot be stored

- (1) The disks for QnACPU do not have any sub-directories. The files are all stored in the root directory.
- (2) Refer to the QnACPU User's Manual (Detailed Version) for the restrictions and details of the QnACPU user files.

13.6.3 Response Code

For information regarding the response codes that are returned to the remote node (FTP client) by the QE71 (FTP server), refer to the manual for the FTP client for the codes except the following 4000H.

Response code	Reference
Other than the following	Refer to the manual for the FTP client.
4000H to 4FFFH	Refer to the QnACPU User's Manual (Detailed version) and correct.
C000H to CFFFH	Refer to Item 17.1.3 and correct.

Remarks

The first two digits of the response code is described below:

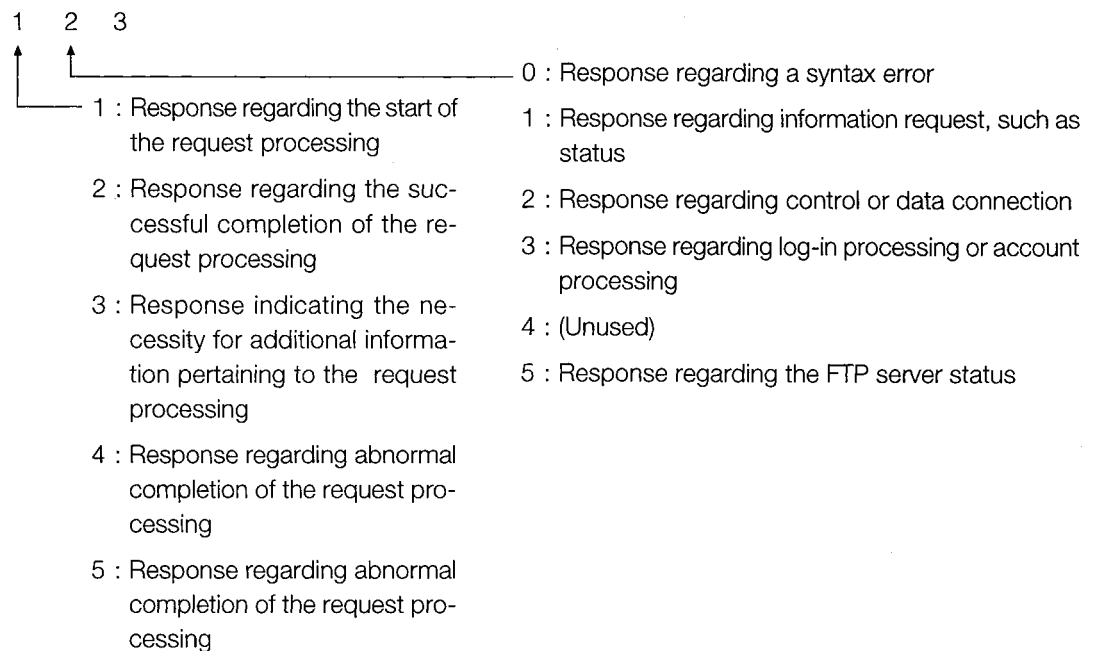

13.6.4 FTP Operation Command

The FTP operation command functions and usage on the FTP client (remote node) side supported by the QE71 FTP server are described.

 **CAUTION**

- Some of the FTP operation commands on the FTP client (remote node) side supported by the QE71 may not perform as described in this manual, depending on the FTP application used on the client side.

Refer to the manual for the FTP client (remote node) as well, and confirm the functions and operation methods.

1

FTP server support commands**● binary**

[Function] Notifies to the FTP server that the file transfer is performed without converting the file.

The carriage return code and kanji code are not converted, either.

The QE71 is automatically set to this.

[Specification format] binary (Abbreviated as bin)

● bye

[Function] Shuts down the FTP server connection, and ends FTP.

[Specification format] bye

[Same function] quit

● close

[Function] Shuts down the FTP server connection.

[Specification format] close

● delete

[Function] Deletes the file stored in the QnACPU.

[Specification format] delete FILE PATH

[Specification example] To delete a file stored in the RAM of memory card A:

delete 1:\MAINSEQ1.QPG.

[Caution] • Refer to Items 13.5 and 13.6.1.

[Similar function] mdelete

● dir

[Function] Displays the file names, created dates, and sizes of the files stored in QnACPU.

[Specification format] dir [drive name:]

[Specification example] To display detailed information of files stored in the RAM of memory card B:

dir 3:\

[Similar function] ls

● get

[Function] Reads the file from the QnACPU.

[Specification format] `get TRANSFER ORIGIN FILE PATH [transfer destination file path]`

[Specification example 1] Reads the file stored in the RAM area of memory card A, and stores using the same file name:

```
get 1:\MAINSEQ1.QPG
```

[Specification example 2] To read the file stored in the RAM area of memory card B, and store using a different file name:

```
get 3:\SEQ1BAK.QPG \SEQ\SEQ1OLD.QPG
```

[Caution] • When the transfer destination file path (FTP client side) is not specified, the file is stored in the FTP client side with the same name as the transfer origin file name (on the QnACPU side).

The transfer destination is the connected current directory of the FTP startup connection.

- Refer to Items 13.5 and 13.6.1.

● ls

[Function] Display the file names of the files stored in the QnACPU.

[Specification format] `ls [drive name:]`

[Specification example] To display the file names of the files stored in the RAM area of memory card B:

```
ls 3:\
```

[Similar function] `dir`

● mdelete

[Function] Deletes the file stored in the QnACPU.

When deleting the multiple files, the file name and extension are specified using wild cards (* or ?).

[Specification format] `mdelete FILE PATH (abbreviated as mdel)`

[Specification example] To delete all files with the extension "QPG" in the files stored in the RAM area of memory card A:

```
mdelete 1:\*.QPG
```

[Caution] • Refer to Items 13.5 and 13.6.1

[Similar function] `delete`

● **mdir**

[Function] Stores the detailed information (file name, created date, and size) of the files stored in the QnACPU to the FTP client-side file as log data.

[Specification format] `mdir transfer origin drive:\ transfer destination file path`

[Specification example] To store the detailed information of the files stored in the RAM area of memory card B to S970415.LOG file:

```
mdir 3:\ S970415.LOG
```

- [Caution]
- Always specify “\” directly after the drive name of the transfer origin.
 - When specifying the transfer destination file path (FTP client side), always specify the transfer origin drive name.
 - When the transfer destination file path is not specified, the file name set by the FTP application on the FTP client side is used to save the file.
 - The transfer destination is the connected current directory of the FTP startup connection.

[Similar function] `mls`

● **mget**

[Function] Reads a file from QnACPU.

When reading multiple files, the file name and extension for the file path is specified using wild cards (* or ?).

Reception is confirmed for each file transfer.

[Specification format] `mget FILE PATH`

[Specification example] To read all files with extension “QPG” from the files stored in the RAM area of memory card A:

```
mget 1:\ *.QPG
```

- [Caution]
- The files read are stored on the FTP client side with the same file name.
The destination is the connected current directory of the FTP startup connection.
 - Refer to Items 13.5 and 13.6.1.

● mls

[Function] Stores file names of the files stored in the QnACPU in a file on the FTP client side as log data.

[Specification format] mls transfer origin drive name:\ transfer destination file path name

[Specification example 1] To store the file names of the files stored in the RAM area of memory card B to the file S970415F.LOG:

```
mls 3:\ S970415F.LOG
```

[Specification example 2] To store the file names of the files in the disk where the parameter file used for the current operation of QnACPU is stored to the file S970415F.LOG:

```
mls \ S970415F.LOG
```

- [Caution]
- Always specify “\” directly after the drive name of the transfer origin.
 - When specifying the transfer destination file path (FTP client side), always specify the transfer origin drive name.
 - When the transfer destination file path is not specified, the file name set by the FTP application on the FTP client side is used to save the file.
 - The transfer destination is the connected current directory of the FTP startup connection.

[Similar function] mdir

● mput

[Function] Writes a file to the QnACPU.

When writing multiple files, the file name and extension are specified using wild cards (* or ?).

When writing multiple files, the transmission confirmation is performed for each file transfer.

[Specification format] mput TRANSFER ORIGIN FILE PATH

[Specification example] When writing all files with extension “QPG”:

```
mput *.QPG
```

- [Caution]
- The transfer destination is the disk (F:) where the parameter file used for the current operation of QnACPU is stored.
The destination file name is the same as the file name on the FTP client side.
 - Refer to Items 13.5 and 13.6.1.

● open

[Function] Connects to the FTP server by specifying the host name or IP address for the FTP server, along with the FTP log-in name and password.
FTP server host name is displayed while connected to the server.

[Specification format] open HOST NAME [user name [password]]
open IP ADDRESS [user name [password]]

Host name : Host name, domain name or synonym of the host name

IP address : IP address for QE71 (specified within brackets [])

User name : FTP log-in name set during QE71 initial processing

Password : Password set during QE71 initial processing

(Refer to Item 13.3 for the FTP log in name and password)

[Specification example 1] To connect to the FTP server by specifying the host name:
open HOST

[Specification example 2] To connect to the FTP server by specifying the IP address:
open [192.0.1.254]

[Specification example 3] To connect to the FTP server by specifying the host name and user name:
open HOST AJ71QE71

[Specification example 4] To connect to the FTP server by specifying the host name, user name, and password:
open HOST AJ71QE71 AJ71QE71

- [Caution]
- Normally, the connection can be established by specifying the FTP server IP address during FTP startup.
 - When specifying the domain name, the DNS environment specification must be defined using the network parameters on the FTP client side.
 - The password entered from the keyboard is not displayed on the screen.

● put

[Function] Writes a file to the QnACPU.

[Specification format] put TRANSFER ORIGIN FILE PATH [transfer destination file path name]

[Specification example 1] To write the file MAINSEQ1.QPG to the RAM area of memory card B with same file name:
put MAINSEQ1.QPG 3:\MAINSEQ1.QPG

[Specification example 2] To write the file MAINSEQ.QPG file to the RAM area of memory card A with different file name:
put MAINSEQ.QPG 1:\MAINSEQ1.QPG

- [Caution]
- When the directory is not specified for the transfer origin file path (FTP client), the file is written to the connected current directory at FTP server startup connection.
 - When the transfer destination file path (FTP server side) is not specified, the file is stored to the disk (F:) where the parameter file used for the current QnACPU operation is stored.
 - Refer to Items 13.5 and 13.6.1.

● pwd

[Function] Displays the QnACPU current directory.

[Specification format] pwd

[Caution] • The QnACPU disks do not have any sub-directories, and the files are stored in the root directory.

Therefore, “\” is displayed as the execution result of the pwd command.

● quit

[Function] Shuts down the connection to the FTP server, and ends FTP.

[Specification format] quit

[Same function] bye

● quote

[Function] Sends the FTP server subcommand (QE71 dedicated command).

[Specification format] quote QE71 DEDICATED COMMAND

QE71 dedicated command: Refer to [2](#) .

[Specification example] quote status

[Caution] • Only the QE71 dedicated command shown in [2](#) can be used directly after the quote command.

● rename

[Function] Changes the QnACPU file name.

[Specification format] rename FILE PATH BEFORE CHANGE FILE PATH AFTER CHANGE
(abbreviated as ren)

[Specification example] To change the file name of the file stored in the RAM of memory card A:

rename 1:\MAINSEQ1.QPG 1:\SEQ1OLD.QPG

[Caution] • Refer to Items 13.5 and 13.6.1.

● user

[Function] Enter the user name and password for the connected FTP server.

[Specification format] user USER NAME [password]

User name : FTP log-in name set during QE71 initial processing

Password : Password set during QE71 initial processing

(Refer to Item 13.3 for the FTP log in name and password.)

[Specification example 1] To specify the user name:

user AJ71QE71

[Specification example 2] To specify both user name and password:

user AJ71QE71 AJ71QE71

[Caution] • The password entry from the keyboard is not displayed.

2

QE71 dedicated commands

The QE71 dedicated commands to be attached to the FTP operation command “quote” are described.

Point

When performing a remote stop (status control) to the local station QnACPU with QE71 installed, start file transfer by performing one of the following on the QE71 side so that the file transfer is not interrupted even if the QnACPU is switched set to the stop state.

- Turn on the exchange condition setting switch (SW3:automatic startup mode setting) to startup the QE71.
(Refer to Items 4.4, 5.1 2, and 5.2.1.)
- Turn on bit 15 of the exchange instruction area during STOP (exchange is possible even when the initial request signal is off). (Refer to Item 16.2.)

When none of the above is performed, the output signals from the QnACPU to the QE71 is turned off when the remote stop is performed, so the exchange line is closed.

Therefore, from that point on, no data exchange can be established including the QnACPU status control from the remote node.

● **change** (QE71 dedicated command)

[Function] Displays/changes the file attribute for the file stored in the QnACPU.

[Specification format] When displaying the file attribute:

quote change FILE PATH

Either of the following is displayed as the execution result after a successful completion:

- When the specified file is a read-only file: "-----r"
- When the specified file is a file with read/write enabled: "-----w"

[Specification format] When changing the file attribute

quote change FILE PATH ATTRIBUTE

Specify either of the following for the attribute:

- To change to read-only file : r
- To change to read/write enabled : w

[Specification example 1] To display the file attribute for the file stored in the RAM area of memory card A:

quote change 1:\MAINSEQ1.QPG

[Specification example 2] To change the file attribute of the file stored in the RAM area of memory card A:

quote change 1:\MAINSEQ1.QPG r

[Caution] • When the PLC CPU is set to RUN, an error occurs when the following files are specified:

Parameter file

File currently being executed by the built-in RAM (drive name:0)

- The attribute changing is possible between read-only file and read/write enabled file.
- Refer to Items 13.5 and 13.6.1.

Point

The file attributes specified using the quote change command are described.

- (1) When changing the attribute of the file for file transfer, specify the attribute after the change.
- (2) The attributes are for changing the file to read-only or read/write enabled file.
- (3) The attribute can be changed to the following for the files stored in the QnACPU disk using this command:
"r" (read-only) ↔ "w" (read/write enabled)
- (4) A user-created file has the read/write attribute, if it has not been changed.

● **keyword-set** (QE71 dedicated command)

[Function] Sets the keyword registered to the QnACPU file transfer drive to the QE71.

Or, the keyword currently set in the QE71 is displayed and/or cleared.

* This command can only be used when the keyword is registered in the QnACPU drive. When this keyword is registered in the QE71, when the QE71 makes a file access to the QnACPU this keyword is compared with the QnACPU keyword.

[Specification format] `quote keyword-set [keyword]`

Keyword : Specify the keyword (string) registered in the QnACPU corresponding drive.

To clear the keyword set in the QE71, specify "****".

One of the following is displayed as an execution result when completed successfully:

- When setting the keyword : "200 Command successful"
- When displaying the keyword : "200 keyword is [keyword]"
- When clearing the keyword : "200 Command successful"

[Specification example 1] To set the keyword (1234) to the QE71:

`quote keyword-set 1234`

[Specification example 2] To display the keyword currently set in the QE71:

`quote keyword-set`

[Specification example 3] To clear the keyword currently set in the QE71:

`quote keyword-set ****`

[Caution] • When the keyword is registered for the QnACPU file transfer drive, set the keyword to the QE71 using this command before file transfer to this drive is performed.

By specifying the keyword registered to the QnACPU drive, the QnACPU file operations can be performed.

- One keyword can be set in the QE71. If the file transfer target QnACPU drive changes, reset the target drive keyword in the QE71 when the keyword of the switch destination drive is also registered.
- When logging into the QE71 from a remote node, the keyword set for the QE71 changes to "****" (cleared).

Point

The keyword specified using the `quote keyword-set` command is described:

- (1) When the keyword is registered to the QnACPU file transfer drive, set the keyword registered to the QE71 using this command before performing file transfers to that drive after logging into the QE71.
- (2) The keyword is for the QnACPU to enable/prohibit access to the corresponding drive from an external source.
- (3) The keyword registration to the QnACPU is performed using the GPP.
The keyword specified by this command is for operations with the QE71.
The text string registered with GPP is specified by the user to the QnACPU specified drive.

● **run** (QE71 dedicated command)

[Function] Sets the QnACPU to the run state (remote run).

Device memory clear can be specified when setting to the run state.

[Specification format] quote run [mode [clear mode]]

Mode : Specify whether to force a remote run.

0 : Normal run (default value)

1 : Forced run

Clear mode : Specify whether to clear (initialize) the QnACPU device memory when starting the remote run operation.

0 : Do not clear the device (default value)

1 : Clear everything except for the latch range

2 : Clear everything including the latch range

The following message is displayed as the execution result when completed successfully.

- Displayed message: "200 Command successful"

[Specification example 1] To perform a normal remote run with the specification not to clear the device memory.

quote run

[Specification example 2] To perform a forced remote run with the specification not to clear device memory.

quote run 1

[Specification example 3] To perform a forced remote run with the specification to clear all device memory except for the latch range.

quote run 1 1

[Caution] • The forced execution mode is only used to allow forced remote runs from another device when the QnACPU cannot perform remote runs due to problems in the equipment which issued the remote stop for the QnACPU.

When a normal run is specified and the system is already set to the stop or pause state by another equipment, the system is not set to the run state.

- Specify the clear mode of the device memory during the operation startup depending on the system configurations.

After the QnACPU performs the clear operation, the system runs according to the parameter settings (PLC file setting → device initial values).

● **status** (QE71 dedicated command)

[Function] Displays the QnACPU operation information is displayed.

This is a command to check the QnACPU operation information before executing file transfer to the QnACPU.

[Specification format] quote status

One of the following is displayed as the execution result for a successful completion.

- When the QnACPU is at a run state : "RUN"
- When the QnACPU is at the stop state : "STOP"
- When the QnACPU is a pause state : "PAUSE"

● **stop** (QE71 dedicated command)

[Function] Set the QnACPU to the stop state (remote stop).

[Same function] quote stop

The following message is displayed as the execution result for a successful completion.

- Displayed message: "200 Command successful"

[Caution] • For the QnACPU program file, etc., write this command after the QnACPU is in the stop state.

14. WHEN THE QnACPU ACCESSES THE REMOTE STATION PLC USING THE DATA LINK COMMAND

By using the MELSECNET/10 relay exchange function, the Ethernet network system is regarded as the same class as the MELSECNET/10 network system, therefore, the QnACPU can perform data exchange with the remote station PLC CPUs on the same Ethernet using the data link commands.(UDP/IP communication)

Also, by using the router relay function, data exchange can be performed with the PLC CPUs on remote Ethernet network.

In this chapter, the usage of the data link commands, etc. are described when the local station QnACPU performs data exchange with the remote station PLC CPU with the QE71 via Ethernet or MELSECNET/10.

Point

- (1) The remote station access using the data link command via QE71 can be performed if the local station QnACPU is the product shown in Item 2.5.3 .
- (2) When accessing remote stations using data link commands via QE71, set the parameters shown in Chapter 15.

14.1 Remote Station Access with the Data Link Command

The data link command is a command for the QnACPU to perform data send/receive, read/write of the word device memory, and remote station access such as remote RUN/STOP to the remote station QnACPU connected to the MELSECNET/10 or Ethernet.

As long as the local station, relay station, and access station have successfully completed the QE71 initial processing, the remote station access is possible using the data link command.

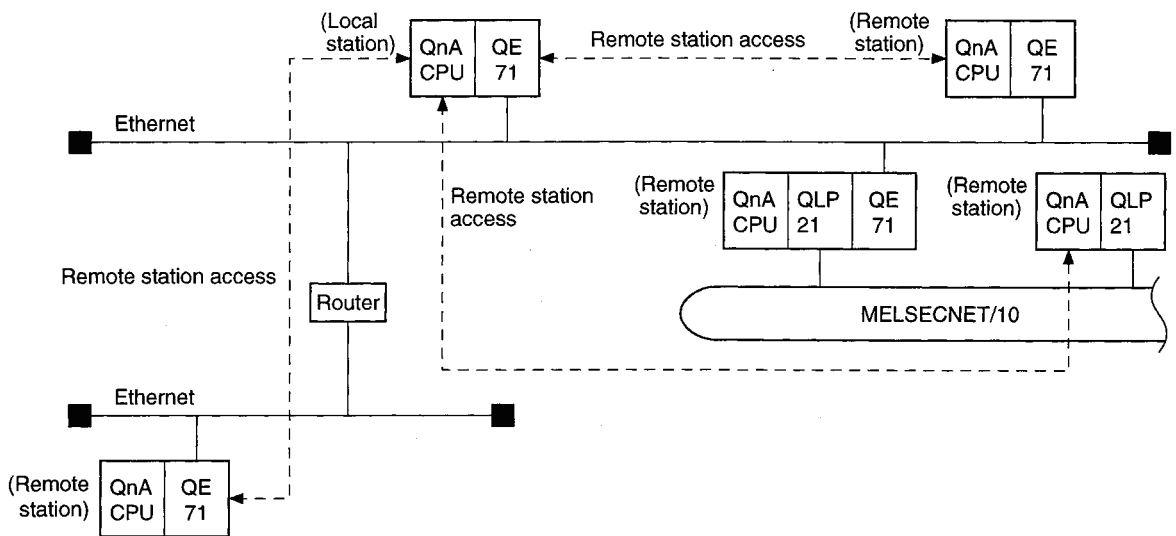

14.2 Remote Station Access Function Using the Data Link Command

The remote station access functions from the local station QnACPU via QE71 are described below.

Command	Function	Accessing station (exchange request destination station)				Detailed explanation
		QnA	AnU	AnA	Other	
SEND	Send data.	○		×		Item 14.4.1
RECV	Read data received.	○		×		
READ	Read the remote station's word device data.	○		×		
SREAD	Read the remote station's word device data, and turn on the specified bit device of the remote station (one scan).	○		×		Item 14.4.2
WRITE	Write data to the remote station's word device.	○		×		
SWRITE	Write data to the remote station's word device, and turn on the specified bit device of the remote station (one scan).	○		×		
ZNRD	Read data from the remote station word device.			○		Item 14.4.3
ZNWR	Write data to the remote station word device.			○		
REQ	Perform remote station status control. (Remote RUN/STOP)	○		×		Item 14.4.4
	Read/write remote station clock data.	○		×		Item 14.4.5
	Read/write local station QE71 EEPROM data.	○		-		Item 14.4.6

○ : Can be accessed × : Cannot access - : System configuration not allowed

Point

- (1) Refer to Chapter 15 for details of the following when performing remote station access using the data link commands.
 - The accessible range and accessible stations of the remote stations
 - Setting to perform remote station access
 - Remote station access procedure
- (2) The exchange using the data link commands on the Ethernet is performed with UDP/IP. When executing each data link command except for ZNRD and ZNWR, it is recommended to specify a value greater than "1" to the number of retries specification area of the control data storage device.
- (3) Refer to the MELSECNET/10 Reference Manual regarding the link data send/receive processing and processing time in data exchange with the remote station QnACPU via MELSECNET/10.
- (4) For details about data specification methods in the data link command, refer to the QnACPU Programming Manual (Common command Edition).

14.3 Precautions When Performing Remote Station Accesses

Precautions when accessing remote stations QE71 using the data link commands are described below.

1

QnACPU software versions

The remote station access using the data link commands can be performed if local station QnACPU is shown in Item 2.5.3.

2

Simultaneous execution of multiple commands

(a) Common for all data link commands

- ① When performing simultaneous remote station accesses to multiple exchange request destination stations from the same exchange request origin station, change the channel number of the exchange request origin station for each exchange request destination station.
- ② When accessing the remote station by specifying the same channel number, perform the second remote station access after the first remote station access is complete. The next remote station access is placed on hold until the first remote station access is complete.
- ③ A maximum of two data-link instructions can be executed during the same scan period.

If more data-link instructions are necessary, adjust the number so that the rest are executed after the current scan.

- * When the access destination stations (communication request destination stations) are different, a maximum of eight instructions can simultaneously be set in the “running” state if the channel numbers (1 to 8) specified in the control data of each instruction are not duplicated.

(b) SEND command

- ① When performing remote station accesses from multiple exchange request origin stations to the same exchange request destination station, change the channel number of the exchange request destination station for each exchange request origin station.
If the channel number is being used at the exchange request origin station (being accessed from another station using the same channel number) when a remote station is accessed, the data link instruction ends in error. So, re-execute the command.

- * If the channel number used is different at the exchange request destination station side, simultaneous remote station access can be performed from a maximum of eight exchange request origin stations to the same station.

- ② When performing remote station access from the same exchange request origin station to the same exchange request destination station, change the channel number at the exchange request destination station.

When specifying the same channel number on the exchange request destination side, perform the second remote station access after the first remote station access is complete. If the second SEND command is executed before the first SEND command is completed, an error command.

(c) Command other than the SEND command

- ① When simultaneous remote station access is performed to the same exchange request destination station from multiple exchange request origin station, and a busy error (being accessed from another station) occurs, re-execute the command.
- ② When accessing remote station from the same exchange request origin station to the same exchange request destination station, execute the second data link command after remote access by the first data link command is complete.

3 Broadcast (Simultaneous broadcast)

When FFH is specified as the target station number in the control data when executing SEND/ WRITE (SWRITE)/REQ on the Ethernet, the command is sent to all remote nodes on the network.

(Example) IP address when the command is sent (for class B)

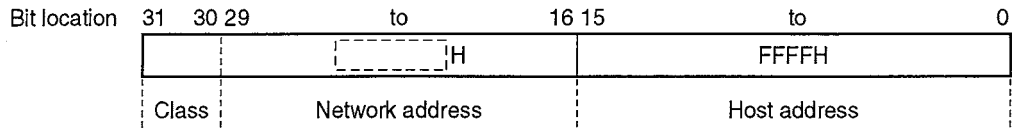

For the external devices on the Ethernet, perform read-dump processing locally for the received commands not related to the local node. Also, do not return a response even if the local node is the target station.

* These processing are performed automatically with the QE71.

4 Interlock when executing the data link command

① Via Ethernet

Execute the data link command when the local station (exchange request origin station) QE71 is at the following I/O signal state.

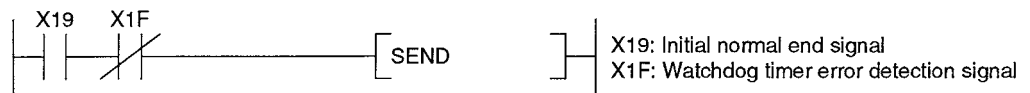

② Via MELSECNET/10

Check the status of the local station (exchange request origin station), exchange relay station, and access destination (exchange request destination station) using the following devices. Execute the data link instruction if the status is normal.

- Link special relay: SB20, SB47, SB70, SB30 to 3E, etc.
- Link special register: SW70 to 73, SW74 to 77, etc.

* Refer to the MELSECNET/10 Reference Manual for the interlock signals, link data send/receive processing, and processing time when performing data exchange with the remote station QnACPU via MELSECNET/10.

5 When executing each data link command except for ZNRD and ZNWR, it is recommended to specify a value greater than "1" for the number of retransmit specification area of the control data storage device.

The resend timing when the READ command is executed after specifying the number of retransmit is described on the next page.

6 For the delivery monitoring time specification area of a control data storage device, specify monitoring time greater than the TCP retransmit timer value specified by the initial processing parameter. If the monitoring time specified is smaller than the TCP retransmit timer value, the TCP retransmit timer value will be used as the delivery monitoring time. (*1)

(If Set value ≤ TCP retransmit timer value, then Delivery monitoring time = TCP retransmit timer value.)

*1 The setting unit for the TCP retransmit timer value and delivery monitoring time are different (0.5 sec. and sec., respectively). However, the TCP retransmit timer value is used as

7

When executing each data link command except for ZNRD and ZNWR, it is recommended to specify a value greater than "1" for the number of retransmit specification area of the control data storage device.

The resend timing when the READ command is executed after specifying the number of retransmit is described below.

(Example) READ command execution timing

- ① Exchange timing when the READ command completed successfully (when retransmit is not performed)

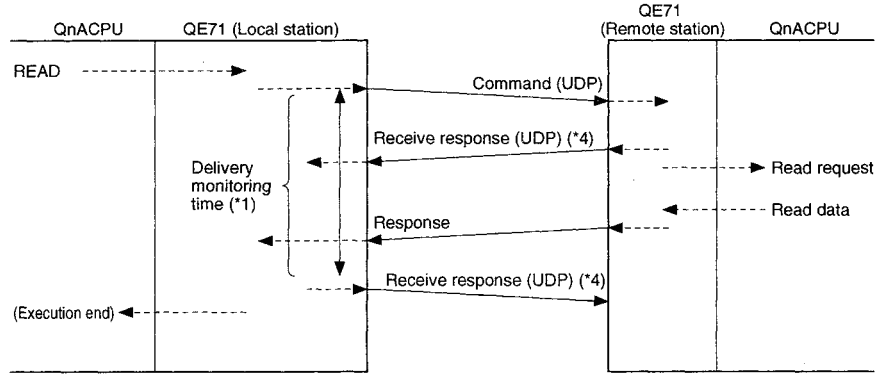

- ② Exchange timing when the READ command completed successfully (when retransmit is performed)

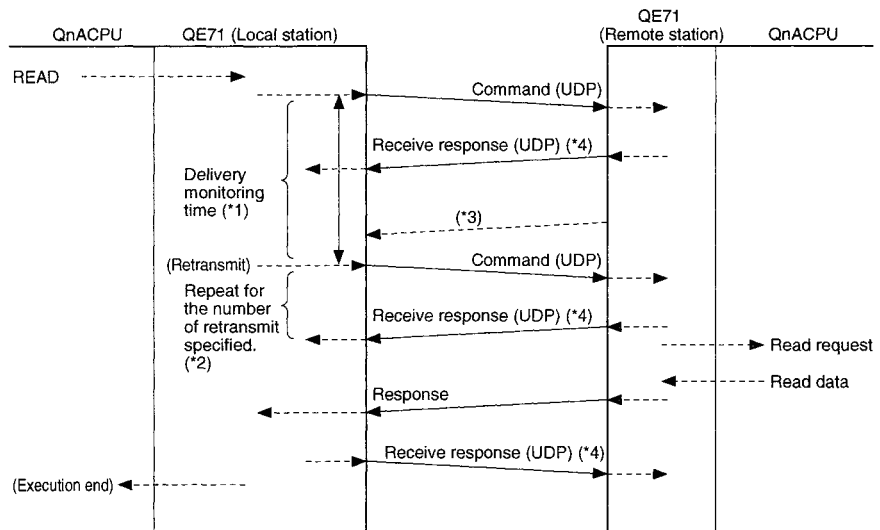

*1 The user specifies the delivery monitoring time with the READ command control data (S1)+8).

*2 The user specifies the number of retransmit with the READ command control data (S1)+7).

*3 Indicates the response not returned within the delivery monitoring time.

The QE71 performs a retransmit of the command for the number of retransmit specified when this response is not received.

*4 The "reception response (UDP)" in the diagram is for the interlock between the QE71, and this is the response to the partner station QE71 from the QE71 OS.

8

Channels used by the ZNRD and ZNWR instructions

The ZNRD and ZNWR instructions for the QE71 are executed using the following channels of the target QE71.

- ZNRD: Channel 1
- ZNWR: Channel 2

Do not use the channels used by the ZNRD and ZNWR instructions listed above for other data link instructions in a QE71 installed station that executes the ZNRD and ZNWR instructions. Also, do not execute data link instructions from other stations on the channels listed above in a QE71 installed station that executes the ZNRD and ZNWR instructions.

14.4 Data Link Commands

The data link command usage method to perform the remote station access via QE71 is described below. The overview of the data send/receive in each command is as shown below.

Command	Details	Command execution station (Local station)		Target station	
		Station type	Station type	PLC CPU type	
				QnA CPU	Other than QnACPU
SEND RECV	<p>Data is sent (SEND) and received (RECV) between the QnACPU stations.</p>	<p>Ethernet network system</p> <p>QE71</p> <p>MELSECNET/10 network system</p> <p>Control station</p> <p>Normal station</p> <p>Remote master station</p> <p>Multiple remote master station</p> <p>Parallel remote master station</p> <p>Multiple remote submaster station</p> <p>Parallel remote submaster station</p>	<p>Ethernet network system</p> <p>QE71</p> <p>MELSECNET/10 network system</p> <p>Control station</p> <p>Normal station</p> <p>Remote master station</p> <p>Multiple remote master station</p> <p>Parallel remote master station</p> <p>Multiple remote submaster station</p> <p>Parallel remote submaster station</p>	○	×
READ SREAD	<p>Reads data from remote station's word device. (With SREAD, device on target station can be turned on.)</p>	<p>Ethernet network system</p> <p>QE71</p> <p>MELSECNET/10 network system</p> <p>Control station</p> <p>Normal station</p> <p>Remote master station</p> <p>Multiple remote master station</p> <p>Parallel remote master station</p> <p>Multiple remote submaster station</p> <p>Parallel remote submaster station</p>	<p>Ethernet network system</p> <p>QE71</p> <p>MELSECNET/10 network system</p> <p>Control station</p> <p>Normal station</p> <p>Remote master station</p> <p>Multiple remote master station</p> <p>Parallel remote master station</p> <p>Multiple remote submaster station</p> <p>Parallel remote submaster station</p>	○	×
WRITE SWRITE	<p>Writes data to remote station's word device. (With SWRITE, device on target station can be turned on.)</p>	<p>Ethernet network system</p> <p>QE71</p> <p>MELSECNET/10 network system</p> <p>Control station</p> <p>Normal station</p> <p>Remote master station</p> <p>Multiple remote master station</p> <p>Parallel remote master station</p> <p>Multiple remote submaster station</p> <p>Parallel remote submaster station</p>	<p>Ethernet network system</p> <p>QE71</p> <p>MELSECNET/10 network system</p> <p>Control station</p> <p>Normal station</p> <p>Remote master station</p> <p>Multiple remote master station</p> <p>Parallel remote master station</p> <p>Multiple remote submaster station</p> <p>Parallel remote submaster station</p>	○	×
REQ	<p>Perform "remote RUN/STOP", "clock data read and write", etc. for remote stations.</p>	<p>Ethernet network system</p> <p>QE71</p> <p>MELSECNET/10 network system</p> <p>Control station</p> <p>Normal station</p> <p>Remote master station</p> <p>Multiple remote master station</p> <p>Parallel remote master station</p> <p>Multiple remote submaster station</p> <p>Parallel remote submaster station</p>	<p>Ethernet network system</p> <p>QE71</p> <p>MELSECNET/10 network system</p> <p>Control station</p> <p>Normal station</p> <p>Remote master station</p> <p>Multiple remote master station</p> <p>Parallel remote master station</p> <p>Multiple remote submaster station</p> <p>Parallel remote submaster station</p>	○	×

Com- mand	Details	Command execution station (Local station)		Target station	
		Station type	Station type	PLC CPU type	
				QnA CPU	Other than QnACPU
ZNRD	<p>Read data from remote station's word device.</p>	<p>[Ethernet network system] QE71</p> <p>[MELSECNET/10 network system]</p> <p>Control station Normal station Remote master station Multiple remote master station Parallel remote master station Multiple remote submaster station Parallel remote submaster station</p>	<p>[Ethernet network system] QE71</p> <p>[MELSECNET/10 network system]</p> <p>Control station Normal station Remote master station Multiple remote master station Parallel remote master station Multiple remote submaster station Parallel remote submaster station</p>	○	○
ZNWR	<p>Write data to remote station's word device.</p>	<p>[Ethernet network system] QE71</p> <p>[MELSECNET/10 network system]</p> <p>Control station Normal station Remote master station Multiple remote master station Parallel remote master station Multiple remote submaster station Parallel remote submaster station</p>	<p>[Ethernet network system] QE71</p> <p>[MELSECNET/10 network system]</p> <p>Control station Normal station Remote master station Multiple remote master station Parallel remote master station Multiple remote submaster station Parallel remote submaster station</p>	○	○

- * The MELSECNET/10 network module in the diagram is indicated as "N/W module" in this item.
- * "Channels 1 to 8" for the QE71 and network module are the OS area for each module in the diagram to store the send/receive data of each data link command.

Point

- (1) For the MELSECNET/10 network number, group number, and station number, for the QE71 in the data link command setting data, specify the network number, group number, and station number, assigned to the QE71 by the Ethernet parameters indicated in Item 15.3.2.
 - * This is so that the Ethernet network system will be considered to be the same class as the MELSECNET/10 network system, to perform remote station accessing processing for the QnACPU.
- (2) For details of the data specification method for the data link command, refer to the QnACPU Programming Manual (Common command Edition).
- (3) A maximum of eight commands can be performed simultaneously, as long as the channel number (1 to 8) specified in each command control data do not overlap with each other when the access destination stations (exchange request destination station) are different.

There are no operation differences in the command format JP.□□ and GP.□□, and J.□□ and G.□□.

! DANGER [Precautions for data link command]

- (1) In a system where QnACPU and AnUCPU coexist, never execute the following command from the QnACPU to remote station's AnUCPU.

The AnUCPU that has been executed such commands results in "MAIN CPU DOWN" or "WDT ERROR," and may stop the operation.

① SEND ② READ ③ SREAD ④ WRITE ⑤ SWRITE ⑥ REQ
- (2) When accessing for all QnACPU stations on the MELSECNET/10 including PLC CPU other than QnACPU, perform the access using the group No. specification.

14.4.1 Send/Receive Data (SEND/RCV)

The command format and program example of the SEND/RCV commands are described.

1 Command format

(a) SEND command

[Network number specification]

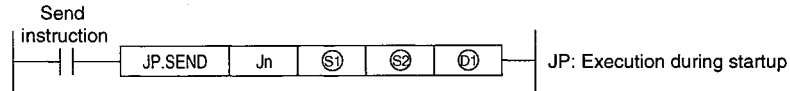

[Network module/QE71 head I/O number specification]

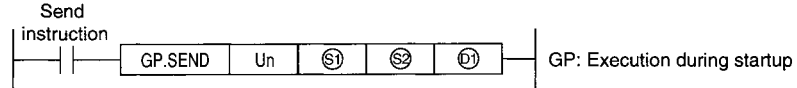

	Setting details	Setting range
Jn	Local station network number	1 to 239: Network number 254 : Network specified in the valid module for remote station access
Un	Local station network module/QE71 head I/O number Specify with two upper digits of the three-digit I/O number.	0 to FEH
S1	Control data storage head device Specify the head device of the local station where the control data is stored.	Word device *2
S2	Send data storage head device Specify the head device of the local station where the send data is stored.	Word device *2
D1	Send completion device Specify the device to turn on one scan when the transmission is complete. D1 OFF: Incomplete ON: Complete D1 +1 OFF: Normal ON: Error	Bit device *1 Word device bit specification *3

*1: Bit device X, Y, M, L, F, V, B

*2: Word device T, C, D, W, ST, R, ZR

*3: Word device bit specification [Word device] . [Bit number]

[Control data structure S1]

For details of each item, refer to the next page.

Device	Item	Data set	
		User (when executing)*1	System (when complete)*2
S1	Execution/error completion type	○	
S1 +1	Completion status		○
S1 +2	Local station usage channel	○	
S1 +3	Target station storage channel	○	
S1 +4	Target station network number	○	
S1 +5	Target station number	○	
S1 +6	(Special function module station number)		
S1 +7	Number of retries	○	○
S1 +8	Delivery monitoring time	○	
S1 +9	Send data length	○	
S1 +10	(Unused)	—	—
S1 +11	Clock set flag		○
S1 +12	Year/month of error completion		○
S1 +13	Day/hour of error completion		○
S1 +14	Minute/second of error completion		○
S1 +15	Day of the week of error completion		○
S1 +16	Error detected network number		○
S1 +17	Error detected station number		○

Used when the error completion type is set to "clock data setting is required."

*1: Item set by sequence program

*2: Item stored when command execution is complete

Control data details

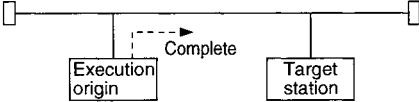
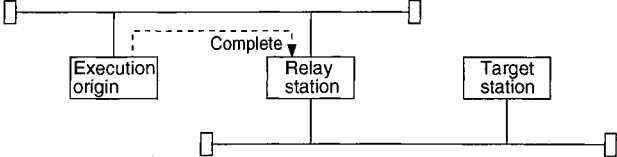
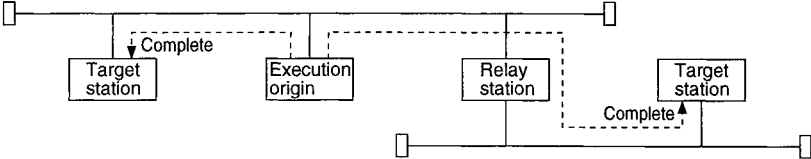
Device	Item	Details				
<p>⑪</p>	<p>Execution/error completion type</p>	<div style="text-align: center;"> <p>b15 to b7 to b0</p> <table border="1" style="margin: auto;"> <tr> <td style="width: 30px; text-align: center;">0</td> <td style="width: 30px; text-align: center;">②</td> <td style="width: 30px; text-align: center;">0</td> <td style="width: 30px; text-align: center;">①</td> </tr> </table> </div> <p>① Execution type (bit 0) 0: No delivery confirmation When the target station is on the local network Complete when data is sent from local station.</p>  <p>When the target station is remote network Complete when the data reaches the local network relay station.</p>  <p>1: Delivery confirmation Complete when the data is stored in the specified channel of the target station</p>  <p>② Error completion type (bit 7) Set the requirement / no-requirement of the clock data setting for error completion 0: Clock data setting is not required Clock data is not set when error occurs in ⑪ +11 to ⑪ +17. 1: Clock data setting is required Clock data is set when error occurs in ⑪ +11 to ⑪ +17.</p>	0	②	0	①
0	②	0	①			
<p>⑪ + 1</p>	<p>Completion status</p>	<p>The instruction completion status is stored. 0 : Normal Other than 0 : Error (Refer to Item 17.1.3 for error codes.)</p>				
<p>⑪ + 2</p>	<p>Local station usage channel</p>	<p>Specify the channel used by the local station. 1 to 8 (channel)</p>				
<p>⑪ + 3</p>	<p>Target station storage channel</p>	<p>Specify the channel of the target station to store data. 1 to 8 (channel)</p>				
<p>⑪ + 4</p>	<p>Target station network number</p>	<p>Specify the target station network number 1 to 239 : Network number 254 : When 254 is specified for Jn (Network specified in the valid module for remote station access)</p>				

Control data details

Device	Item	Details												
Ⓢ +5	Target station number	Specify the target station. (Refer to Item 14.4 "Precautions for data link commands.") 1 to 64 : Station number's station 81H to 89H: Group number's stations (Can be set when the execution type specified in Ⓢ is "0: No delivery confirmation.") FFH : All stations on the target network number. (simultaneous broadcast) (Can be set when the execution type specified in Ⓢ is "0 : No delivery confirmation.")												
Ⓢ +6	(Special function module station number)	Setting not necessary (Specification is valid when the instruction is executed from the special function module.)												
Ⓢ +7	Number of retries	Valid when the execution type specified in Ⓢ is "1: Delivery confirmation." ① During command execution Set the number of retries for when transmission is not complete in the monitoring time specified in Ⓢ +8. 0 to 15 (times) ② When command is complete The number of retries (result) is stored. 0 to 15 (times)												
Ⓢ +8	Delivery monitoring time	Valid when the execution type specified by Ⓢ is "1: Delivery Confirmation." Set the monitoring time until command completion to a value greater than the TCP retransmit timer value. When command is not complete within the monitoring time, the command execution is retransmit for the number of retransmit specified in Ⓢ +7. 0 to TCP retransmit timer value : The TCP retransmit timer value is used as the monitoring time. (TCP retransmit timer value +1) to 16383 : Monitoring time (unit: second)												
Ⓢ +9	Send data length	Specify the number of send data for Ⓢ to Ⓢ +n. 1 to 480 (words)												
Ⓢ +10	(Unused)	—												
Ⓢ +11	Clock set flag	Valid/invalid status of the data in Ⓢ +12 to Ⓢ +17 is stored. 0 : Invalid 1 : Valid												
Ⓢ +12	Year/month of error completion	The year (lower two digits) and month are stored in BCD code. <table border="1" style="margin-left: auto; margin-right: auto;"> <tr> <td style="text-align: center;">b15</td> <td style="text-align: center;">to</td> <td style="text-align: center;">b8</td> <td style="text-align: center;">b7</td> <td style="text-align: center;">to</td> <td style="text-align: center;">b0</td> </tr> <tr> <td colspan="2" style="text-align: center;">Month (01H to 12H)</td> <td colspan="4" style="text-align: center;">Year (00H to 99H)</td> </tr> </table>	b15	to	b8	b7	to	b0	Month (01H to 12H)		Year (00H to 99H)			
b15	to	b8	b7	to	b0									
Month (01H to 12H)		Year (00H to 99H)												
Ⓢ +13	Day/hour of error completion	The day and hour are stored in BCD code. <table border="1" style="margin-left: auto; margin-right: auto;"> <tr> <td style="text-align: center;">b15</td> <td style="text-align: center;">to</td> <td style="text-align: center;">b8</td> <td style="text-align: center;">b7</td> <td style="text-align: center;">to</td> <td style="text-align: center;">b0</td> </tr> <tr> <td colspan="3" style="text-align: center;">Hour (00H to 23H)</td> <td colspan="3" style="text-align: center;">Day (01H to 31H)</td> </tr> </table>	b15	to	b8	b7	to	b0	Hour (00H to 23H)			Day (01H to 31H)		
b15	to	b8	b7	to	b0									
Hour (00H to 23H)			Day (01H to 31H)											
Ⓢ +14	Minute/second of error completion	The minute and second are stored in BCD code. <table border="1" style="margin-left: auto; margin-right: auto;"> <tr> <td style="text-align: center;">b15</td> <td style="text-align: center;">to</td> <td style="text-align: center;">b8</td> <td style="text-align: center;">b7</td> <td style="text-align: center;">to</td> <td style="text-align: center;">b0</td> </tr> <tr> <td colspan="3" style="text-align: center;">Second (00H to 59H)</td> <td colspan="3" style="text-align: center;">Minute (00H to 59H)</td> </tr> </table>	b15	to	b8	b7	to	b0	Second (00H to 59H)			Minute (00H to 59H)		
b15	to	b8	b7	to	b0									
Second (00H to 59H)			Minute (00H to 59H)											
Ⓢ +15	Day of the week of error completion	The day of the week is stored in BCD code. <table border="1" style="margin-left: auto; margin-right: auto;"> <tr> <td style="text-align: center;">b15</td> <td style="text-align: center;">to</td> <td style="text-align: center;">b8</td> <td style="text-align: center;">b7</td> <td style="text-align: center;">to</td> <td style="text-align: center;">b0</td> </tr> <tr> <td colspan="2" style="text-align: center;">00H</td> <td colspan="2" style="text-align: center;">Day of week (00H to 06H)</td> <td colspan="2" style="text-align: center;">00H (Sunday) to 06H (Saturday)</td> </tr> </table>	b15	to	b8	b7	to	b0	00H		Day of week (00H to 06H)		00H (Sunday) to 06H (Saturday)	
b15	to	b8	b7	to	b0									
00H		Day of week (00H to 06H)		00H (Sunday) to 06H (Saturday)										
Ⓢ +16	Error detected network number	The network number of the station where the error was detected is stored.*1 1 to 239 (Network number)												
Ⓢ +17	Error detected station number	The station number where the error was detected is stored.*1 1 to 64 (Station number)												

* 1 The number is not stored when the module that executes the command detected an error at acceptance of the command.

Point

- (1) To increase the data reliability, it is recommended to execute the command with "delivery confirmation" as the execution type when the target station number is specified within 1 to 64. When the target station number is specified within 81H to 89H or FFH, execute the command with the execution type as "no delivery confirmation."
- (2) When sending data to the same channel of the receiving station, execute the command after the receiving station reads data with the RECV command. When the execution type is set to "no delivery confirmation," even if the contents of the sent data is erroneous, the sending station completes the process normally if the communication ends normally. Even if the contents of the transmission is normal, if the command is executed from multiple stations to the same station, the sending station become time out error (C083H).
- (3) When the execution type is set as "delivery confirmation," if the sending station sends data to the same channel in the receiving station before the receiving station reads the data using the RECV command, a buffer full error (C085H) results on the sending side.

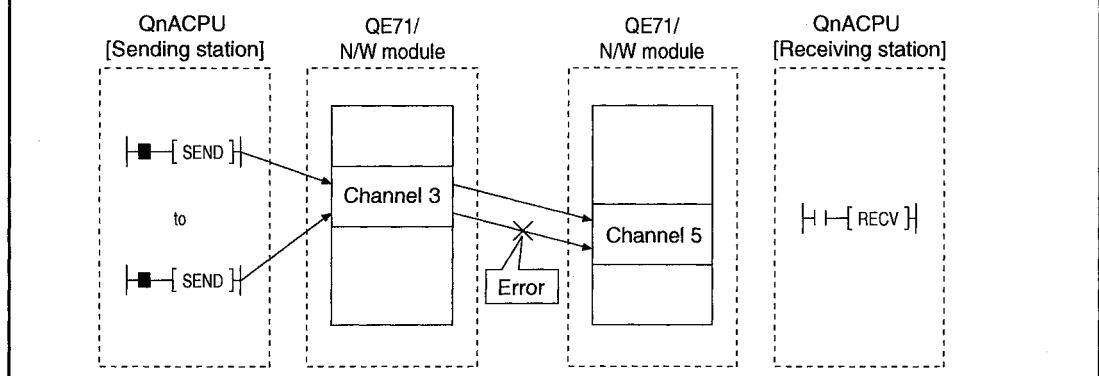

(b) RECV command

[Network number specification]

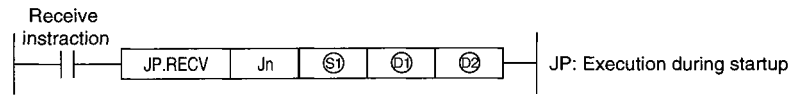

[Network module/QE71 head I/O number specification]

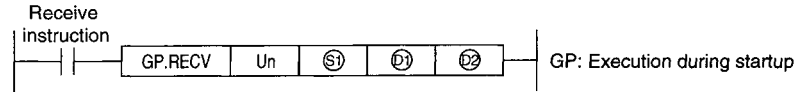

	Setting details	Setting range
Jn	Local station network number	1 to 239: Network number 254 : Network specified in the valid module for remote station access
Un	Local station network module/QE71 head I/O number Specify with two upper digits of the three digit I/O number.	0 to FEH
S1	Control data storage head device Specify the head device of the local station where the control data is stored.	Word device *2
D1	Receive data storage head device Specify the head device of the local station where the received data is stored.	Word device *2
D2	Receive completion device Specify the device to turn on one scan when the receive is complete. D2 OFF: Incomplete ON: Complete D2 +1 OFF: Normal ON: Error	Bit device *1 Word device bit specification *3

*1: Bit device X, Y, M, L, F, V, B

*2: Word device T, C, D, W, ST, R, ZR

*3: Word device bit specification [Word device], [Bit number]

[Control data structure S1]

For details of each item, refer to the next page.

Device	Item	Data set	
		User (when executing)*1	System (when complete)*2
S1	Execution error completion type	○	
S1 +1	Completion status		○
S1 +2	Local station usage channel	○	
S1 +3	Sending station usage channel		○
S1 +4	Sending station network number		○
S1 +5	Sending station number		○
S1 +6	(Unused)	—	—
S1 +7	(Unused)	—	—
S1 +8	Delivery monitoring time	○	
S1 +9	Receiving data length		○
S1 +10	(Unused)	—	—
S1 +11	Clock set flag		○
S1 +12	Year/month of error completion		○
S1 +13	Day/hour of error completion		○
S1 +14	Minute/second of error completion		○
S1 +15	Day of week of error completion		○

Used when the error completion type is set to "clock data setting is required."

*1: Item set by sequence program

*2: Item stored automatically when command execution is complete

Control data details

Device	Item	Details														
⑤	Execution error completion type	<table border="1" style="width: 100%; text-align: center;"> <tr> <td>b15</td> <td>to</td> <td>b8</td> <td>b7</td> <td>b6</td> <td>to</td> <td>b0</td> </tr> <tr> <td>0</td> <td>to</td> <td>0</td> <td>①</td> <td>0</td> <td>to</td> <td>0</td> </tr> </table> <p>① Error completion type (bit 7) Set the requirement/no-requirement of the clock data setting for error completion. 0 : Clock data setting is not required ... Clock data is not set when error occurs in ⑤+ 11 to ⑤+ 15. 1 : Clock data setting is required Clock data is set when error occurs in ⑤+ 11 to ⑤+ 15.</p>	b15	to	b8	b7	b6	to	b0	0	to	0	①	0	to	0
b15	to	b8	b7	b6	to	b0										
0	to	0	①	0	to	0										
⑤ + 1	Completion status	The command completion status is stored. 0 : Normal Other than 0 : Error (Refer to Item 17.1.3 for error codes.)														
⑤ + 2	Local station storage channel	Specify the channel where the data to read is stored. 1 to 8 (channels)														
⑤ + 3	Sending station usage channel	The channel number sending station used is stored. 1 to 8 (channels)														
⑤ + 4	Sending station network number	The network number of the sending station is stored. 1 to 239: Network number														
⑤ + 5	Sending station number	Specify the station number of the sending station. 1 to 64: Station numbers (Reception from station number's station)														
⑤ + 6	(Unused)	—														
⑤ + 7	(Unused)	—														
⑤ + 8	Delivery monitoring time	Set the monitoring time until command completion to a value greater than the TCP retransmit timer value. When the command is not complete within the monitoring time it will be an error completion. 0 to TCP retransmit timer value : The TCP retransmit timer value is used as the monitoring time. (TCP retransmit timer value + 1) to 16383 : Monitoring time (unit: second)														
⑤ + 9	Receiving data length	The number of received data stored in ⑤ to ⑤ + n is stored. 1 to 480 (words)														
⑤ + 10	(Unused)	—														
⑤ + 11	Clock set flag	Valid/invalid status of the data in ⑤ + 12 to ⑤ + 15 is stored. 0 : Invalid 1 : Valid														
⑤ + 12	Year/month of error completion	The year (lower two digits) and month are stored in BCD code. <table border="1" style="width: 100%; text-align: center;"> <tr> <td>b15</td> <td>to</td> <td>b8</td> <td>b7</td> <td>to</td> <td>b0</td> </tr> <tr> <td colspan="3">Month (01H to 12H)</td> <td colspan="3">Year (00H to 99H)</td> </tr> </table>	b15	to	b8	b7	to	b0	Month (01H to 12H)			Year (00H to 99H)				
b15	to	b8	b7	to	b0											
Month (01H to 12H)			Year (00H to 99H)													
⑤ + 13	Day/hour of error completion	The day and hour are stored in BCD code. <table border="1" style="width: 100%; text-align: center;"> <tr> <td>b15</td> <td>to</td> <td>b8</td> <td>b7</td> <td>to</td> <td>b0</td> </tr> <tr> <td colspan="3">Hour (00H to 23H)</td> <td colspan="3">Day (01H to 31H)</td> </tr> </table>	b15	to	b8	b7	to	b0	Hour (00H to 23H)			Day (01H to 31H)				
b15	to	b8	b7	to	b0											
Hour (00H to 23H)			Day (01H to 31H)													
⑤ + 14	Minute/second of error completion	The minute and second are stored in BCD code. <table border="1" style="width: 100%; text-align: center;"> <tr> <td>b15</td> <td>to</td> <td>b8</td> <td>b7</td> <td>to</td> <td>b0</td> </tr> <tr> <td colspan="3">Second (00H to 59H)</td> <td colspan="3">Minute (00H to 59H)</td> </tr> </table>	b15	to	b8	b7	to	b0	Second (00H to 59H)			Minute (00H to 59H)				
b15	to	b8	b7	to	b0											
Second (00H to 59H)			Minute (00H to 59H)													
⑤ + 15	Day of the week of error completion	The day of the week is stored in BCD code. <table border="1" style="width: 100%; text-align: center;"> <tr> <td>b15</td> <td>to</td> <td>b8</td> <td>b7</td> <td>to</td> <td>b0</td> </tr> <tr> <td colspan="3">00H</td> <td colspan="3">Day of week (00H to 06H)</td> </tr> </table> 00H (Sunday) to 06H (Saturday)	b15	to	b8	b7	to	b0	00H			Day of week (00H to 06H)				
b15	to	b8	b7	to	b0											
00H			Day of week (00H to 06H)													
⑤ + 16	Error detected network number	The network number of the station where the error was detected is stored.*1 1 to 239 (Network number)														
⑤ + 17	Error detected station number	The station number where the error was detected is stored.*1 1 to 64 (Station number)														

* 1 The number is not stored when the module that executes the command detected an error at acceptance of the command.

Point

- (1) The receiving data storage device (D) requires a continuous area (max. 480 words) for the receiving data length (S)+9).
- (2) Execute the RECV command for every corresponding channel bit which is on (receiving data exists), in the RECV command execution request area in the buffer memory(address: 205).
- (3) When multiple QE71 with the same network No. are installed to a receive station, specify the "Un" to indicate which one is the target of the RECV instruction.

When the "Jn" is specified in the RECV instruction, the PLC CPU will execute the instruction to the module with the smallest starting I/O No.

(Example) To execute the RECV instruction at station No.3 for the SEND instruction from station No.1, specify the "Un" as "U2".

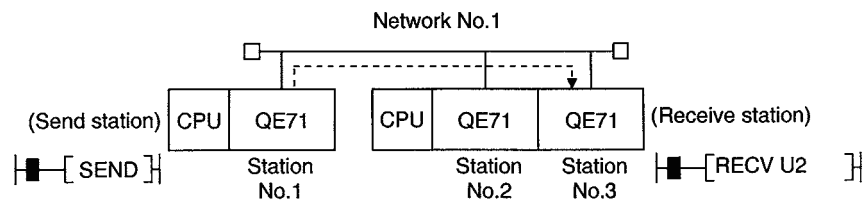

2 Command execution timing

(a) When normal completion

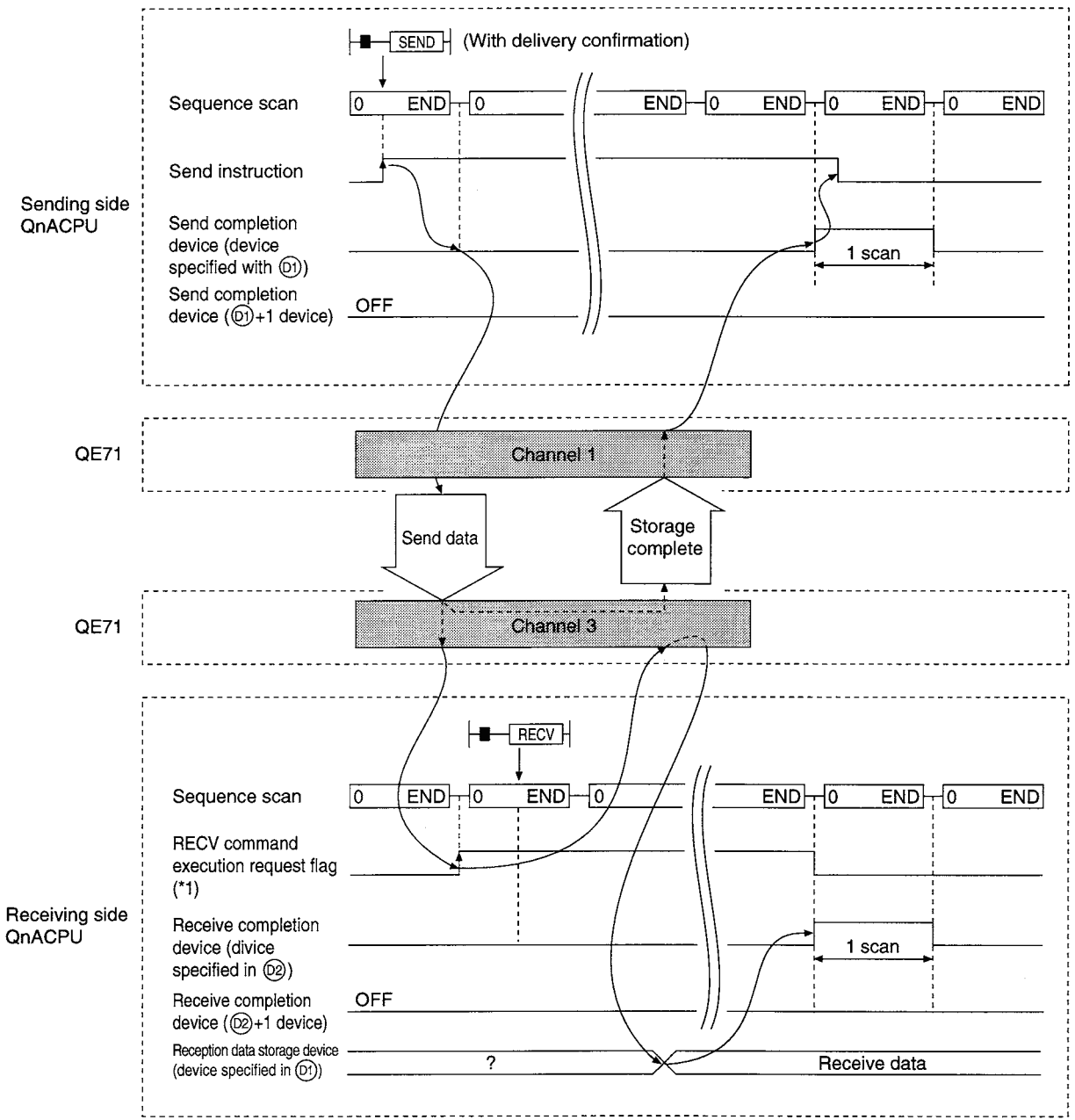

*1 The RECV command execution request flag for Channel 3 used at the receiving side QnACPU is as shown below.

For QE71 : Bit 2 of the RECV command execution request area in the buffer memory (address: 205)

For the N/W module : SBA2 of the link special relay

(b) When error completion
 1) SEND command

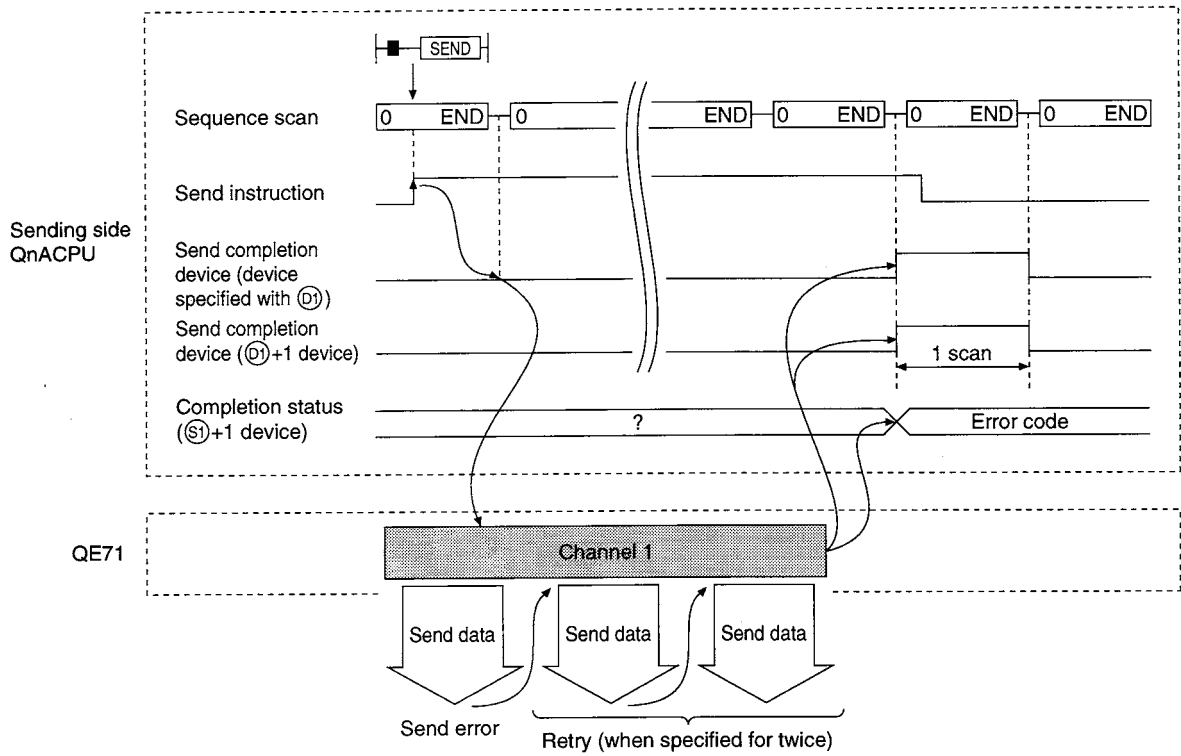

2) RECV command

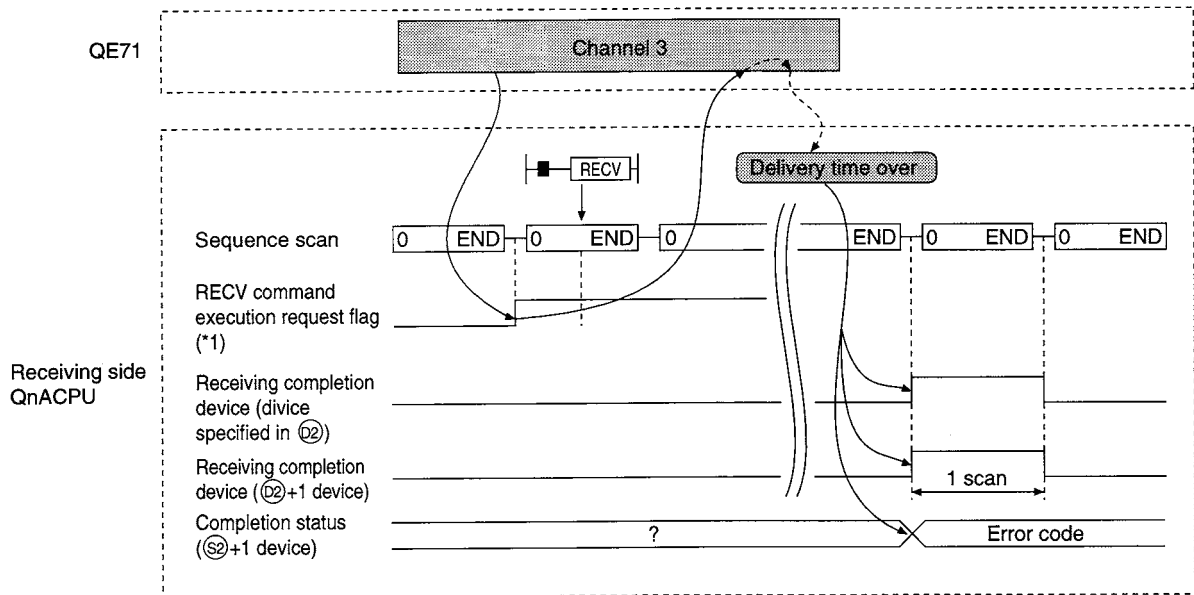

*1 The RECV command execution request flag for Channel 3 used at the receiving side QnACPU is as shown below.

For QE71 : Bit 2 of the RECV command execution request area in the buffer memory (address: 205)

For the NW module : SBA2 of the link special relay

3 Program example

Station 3 uses channel 3 with a SEND command, and sends data to station 15 using channel 5. When data is received at station 15, data is read from channel 5.

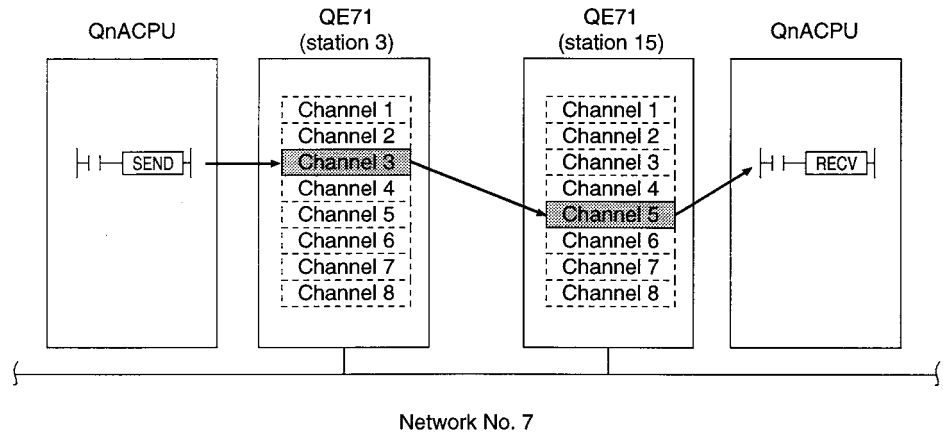

(a) Station 3 program (SEND command)..... (For QE71)

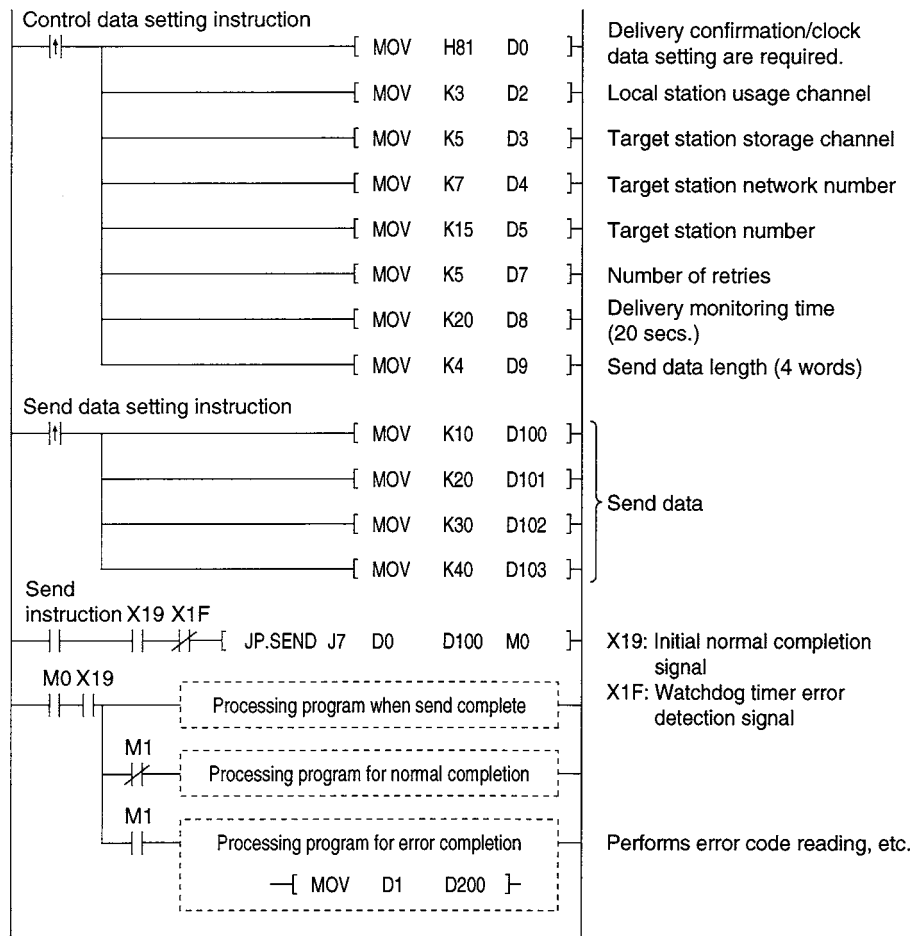

(b) Station 15 program (RECV command) (For QE71)

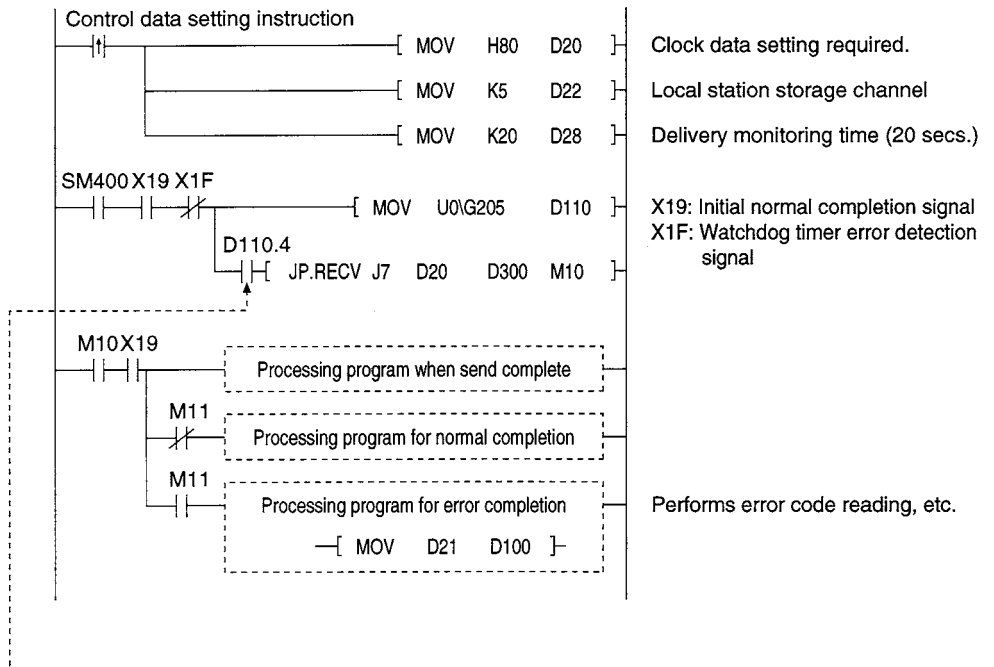

When the data is stored in the receiving station channel, the bit corresponding to each channel of buffer memory RECV command execution request area turns on. Using this signal for receive instruction, data can be read automatically. The signal turns off when RECV is complete.

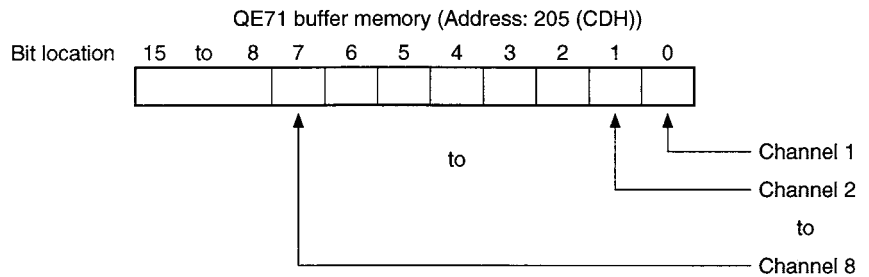

14.4.2 Read/Write Word Device of Remote Stations (READ/WRITE)

The command format and program example of the READ/WRITE commands are described.

1 Command format

(a) READ, SREAD commands

[Network number specification]

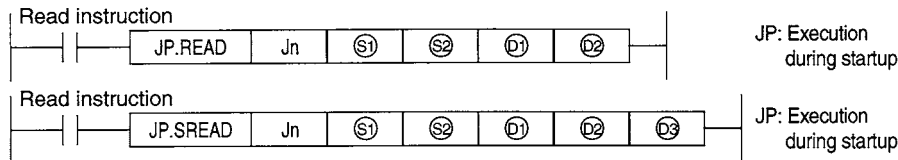

[Network module/QE71 head I/O number specification]

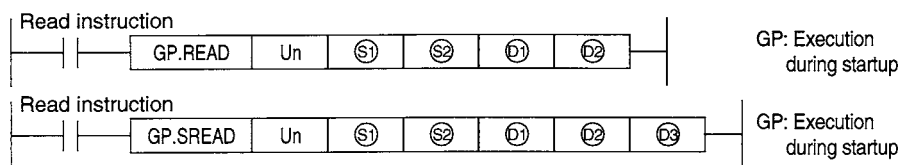

	Setting details	Setting range
Jn	Local station network number	1 to 239: Network number 254 : Network specified in a valid module for remote station access.
Un	Local station network module/QE71 head I/O number Specify with two upper digits from the three digit I/O number.	0 to FEH
S1	Control data storage head device Specify the head device of the local station where the control data is stored.	Word device *2
S2	Read data storage head device (target station) Specify the head device of the target station where the data to read is stored.	Word device *2
D1	Read data storage head device (local station) Specify the head device of the local station where the data to read is stored.	Word device *2
D2	Read completion device (local station) Specify the device of the local station to turn on one scan when the read is complete. D2 OFF: Incomplete ON: Complete D2 +1 OFF: Normal ON: Error	Bit device *1 Word device bit specification *3
D3	Read notify device (target station) Specify the device of the target station to turn on one scan when the read is complete. (Can recognize data of target station has been read from remote station.) D3 OFF: Incomplete ON: Complete	Bit device *1 Word device bit specification *3

*1: Bit device X, Y, M, L, F, V, B
 *2: Word device T, C, D, W, ST, R, ZR
 *3: Word device bit specification [Word device], [Bit number]

[Control data structure ⑤]

Device	Item	Data set	
		User (when executing)*1	System (when complete)*2
⑤	Error completion type	○	
⑤ +1	Completion status		○
⑤ +2	Local station storage channel	○	
⑤ +3	(Unused)	—	—
⑤ +4	Target station network number	○	
⑤ +5	Target station number	○	
⑤ +6	(Special function module station number)		
⑤ +7	Number of retries	○	○
⑤ +8	Delivery monitoring time	○	
⑤ +9	Read data length	○	
⑤ +10	(Unused)	—	—
⑤ +11	Clock set flag		○
⑤ +12	Year/month of error completion		○
⑤ +13	Day/hour of error completion		○
⑤ +14	Minute/second of error completion		○
⑤ +15	Day of the week of error completion		○
⑤ +16	Error detected network number		○
⑤ +17	Error detected station number		○

Used when the error completion type is set to "clock data setting is required."

*1: Item set by sequence program *2: Item stored when command execution is complete

Control data details

Device	Item	Details										
⑤	Error completion type	<table border="1" style="margin-left: 20px;"> <tr> <td style="text-align: center;">b15</td> <td style="text-align: center;">to</td> <td style="text-align: center;">b7</td> <td style="text-align: center;">to</td> <td style="text-align: center;">b0</td> </tr> <tr> <td style="text-align: center;">0</td> <td></td> <td style="text-align: center;">①</td> <td></td> <td style="text-align: center;">1</td> </tr> </table> <p>① Error completion type (bit 7) Set the requirement/no-requirement of the clock data setting for error completion. 0 : Clock data setting is not required Clock data is not set when error occurs in ⑤ + 11 to ⑤ + 17. 1 : Clock data setting is required Clock data is set when error occurs in ⑤ + 1 to ⑤ + 17.</p>	b15	to	b7	to	b0	0		①		1
b15	to	b7	to	b0								
0		①		1								
⑤ + 1	Completion status	The command completion status is stored. 0 : Normal Other than 0 : Error (Refer to Item 17.1.3 for error codes.)										
⑤ + 2	Local station usage channel	Specify the channel used by the local station. 1 to 8 (channels)										
⑤ + 3	(Unused)	—										
⑤ + 4	Target station network number	Specify the network number of the target station. 1 to 239 : Network number 254 : When 254 is specified by Jn. (Network specified in the valid module for remote station access)										
⑤ + 5	Target station number	Specify the target station. (Refer to Item 14.4 "Precautions for data link commands.") 1 to 64 : Station number's station										
⑤ + 6	(Special function module station number)	Setting not necessary (Specification is valid when the command is executed from the special function module.)										
⑤ + 7	Number of retries	① During command execution Set the number of retries for when transmission is not complete in the monitoring time specified in ⑤ + 8. 0 to 15 (times) ② When command is complete The number of retries (result) is stored. 0 to 15 (times)										
⑤ + 8	Delivery monitoring time	Set the monitoring time until command completion to a value greater than the TCP retransmit timer value. When the command is not complete within the monitoring time, the command execution is retransmit for the number of retransmit specified in ⑤ + 7. 0 to TCP retransmit timer value : The TCP retransmit timer value is used as the monitoring time. (TCP retransmit timer value + 1) to 16383 : Monitoring time (unit: second)										

Control data details

Device	Item	Details												
Ⓔ+9	Read data length	Specify the number of read data. 1 to 480 (words)												
Ⓔ+10	(Unused)	—												
Ⓔ+11	Clock set flag	Valid/invalid status of the data in Ⓔ+12 to Ⓔ+17 is stored. 0 : Invalid 1 : Valid												
Ⓔ+12	Year/month of error completion	The year (lower two digits) and month are stored in BCD code. <table border="1" style="margin-left: auto; margin-right: auto;"> <tr> <td>b15</td> <td>to</td> <td>b8</td> <td>b7</td> <td>to</td> <td>b0</td> </tr> <tr> <td colspan="3">Month (01H to 12H)</td> <td colspan="3">Year (00H to 99H)</td> </tr> </table>	b15	to	b8	b7	to	b0	Month (01H to 12H)			Year (00H to 99H)		
b15	to	b8	b7	to	b0									
Month (01H to 12H)			Year (00H to 99H)											
Ⓔ+13	Day/hour of error completion	The day and hour are stored in BCD code. <table border="1" style="margin-left: auto; margin-right: auto;"> <tr> <td>b15</td> <td>to</td> <td>b8</td> <td>b7</td> <td>to</td> <td>b0</td> </tr> <tr> <td colspan="3">Hour (00H to 23H)</td> <td colspan="3">Day (01H to 31H)</td> </tr> </table>	b15	to	b8	b7	to	b0	Hour (00H to 23H)			Day (01H to 31H)		
b15	to	b8	b7	to	b0									
Hour (00H to 23H)			Day (01H to 31H)											
Ⓔ+14	Minute/second of error completion	The minute and second are stored in BCD code. <table border="1" style="margin-left: auto; margin-right: auto;"> <tr> <td>b15</td> <td>to</td> <td>b8</td> <td>b7</td> <td>to</td> <td>b0</td> </tr> <tr> <td colspan="3">Second (00H to 59H)</td> <td colspan="3">Minute (00H to 59H)</td> </tr> </table>	b15	to	b8	b7	to	b0	Second (00H to 59H)			Minute (00H to 59H)		
b15	to	b8	b7	to	b0									
Second (00H to 59H)			Minute (00H to 59H)											
Ⓔ+15	Day of the week of error completion	The day of the week is stored in BCD code. <table border="1" style="margin-left: auto; margin-right: auto;"> <tr> <td>b15</td> <td>to</td> <td>b8</td> <td>b7</td> <td>to</td> <td>b0</td> </tr> <tr> <td colspan="3">00H</td> <td colspan="3">Day of week (00H to 06H)</td> </tr> </table> 00H (Sunday) to 06H (Saturday)	b15	to	b8	b7	to	b0	00H			Day of week (00H to 06H)		
b15	to	b8	b7	to	b0									
00H			Day of week (00H to 06H)											
Ⓔ+16	Error detected network number	The network number of the station where the error was detected is stored.*1 1 to 239 (Network number)												
Ⓔ+17	Error detected station number	The station number where the error was detected is stored.*1 1 to 64 (Station number)												

* 1 The number is not stored when the module that executes the command detected an error at acceptance of the command.

Point

- (1) The read data storage device (Ⓔ) requires a continuous area (max. 480 words) for the read data length (Ⓔ+9).
- (2) When reading data from the other station CPU module device with the READ, SREAD commands, specify the device within the range applicable to the host station CPU module.
(Head device number to be read in other station CPU module (Ⓔ)) + (number of read points - 1) ≤ (last device number of host station CPU module*)

*: Last device number in host station CPU module having the same device name as (Ⓔ).

(b) WRITE, SWRITE commands

[Network number specification]

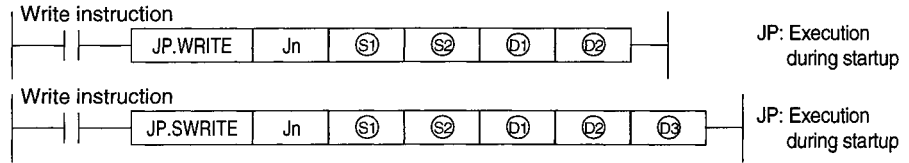

[Network module/QE71 head I/O number specification]

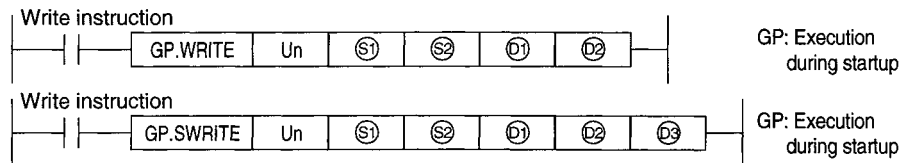

	Setting details	Setting range
Jn	Local station network number	1 to 239: Network number 254 : Network specified in a valid module for remote station access.
Un	Local station network module/QE71 head I/O number Specify with two upper digits of the three digit I/O number.	0 to FEH
S1	Control data storage head device Specify the head device of the local station where the control data is stored.	Word device *2
S2	Write data storage head device (local station) Specify the head device of the local station where the data to write is stored.	Word device *2
D1	Write data storage head device (target station) Specify the head device of the local station where the data is written.	Word device *2
D2	Write completion device (local station) Specify the device of the local station to turn on one scan when the write is complete. D2 OFF: Incomplete ON: Complete D2+1 OFF: Normal ON: Error	Bit device *1 Word device bit specification *3
D3	Write notify device (target station) Specify the device of the target station to turn on one scan when the write is complete. (Can recognize data of target station has been write from remote station.) D3 OFF: Incomplete ON: Complete	Bit device *1 Word device bit specification *3

*1: Bit device X, Y, M, L, F, V, B

*2: Word device T, C, D, W, ST, R, ZR

*3: Word device bit specification [Word device] . [Bit number]

[Control data structure ⑪]

Refer to the next page for details of each item.

Device	Item	Data set	
		User (when executing)*1	System (when complete)*2
⑪	Execution/error completion type	○	
⑪ +1	Completion status		○
⑪ +2	Local station usage channel	○	
⑪ +3	(Unused)	—	—
⑪ +4	Target station network number	○	
⑪ +5	Target station number	○	
⑪ +6	(Special function module station number)		
⑪ +7	Number of retries	○	○
⑪ +8	Delivery monitoring time	○	
⑪ +9	Write data length	○	
⑪ +10	(Unused)	—	—
⑪ +11	Clock set flag		○
⑪ +12	Year/month of error completion		○
⑪ +13	Day/hour of error completion		○
⑪ +14	Minute/second of error completion		○
⑪ +15	Day of the week of error completion		○
⑪ +16	Error detected network number		○
⑪ +17	Error detected station number		○

Used when the error completion type is set to "clock data setting is required."

*1: Item set by sequence program

*2: Item stored when command execution is complete

Control data details

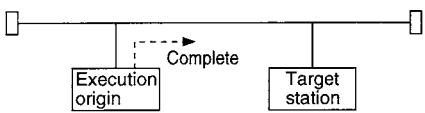
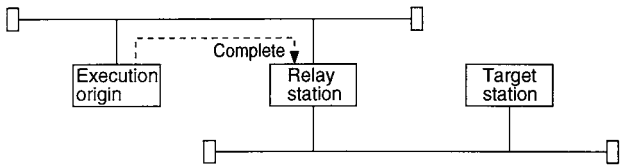
Device	Item	Details
⑪	Execution/error completion type	<p>b15 to b7 to b0</p> <p>0 ② 0 ①</p> <p>① Execution type (bit 0) 0 : No delivery confirmation When the target station is on the local network Complete when data is sent from local station.</p>  <p>When the target station is on remote network Complete when the data reaches the local network relay station.</p> 

Control data details

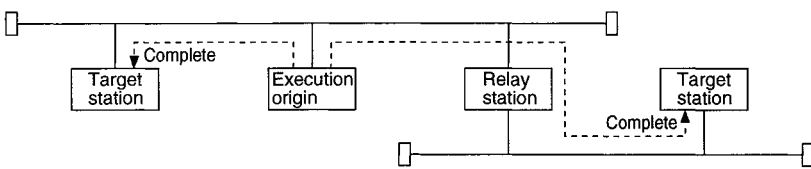
Device	Item	Details
⑤	Execution/error completion type	<p>1 : Delivery confirmation Complete when the data is written to the target station.</p>  <p>② Error completion (bit 7) Set the requirement/no-requirement of the clock data setting for error completion 0 : Clock data setting is not required Clock data is not set when error occurs in ⑤ +11 to ⑤ +17. 1 : Clock data setting is required Clock data is set when error occurs in ⑤ +11 to ⑤ +17.</p>
⑤ + 1	Completion status	The command completion status is stored. 0 : Normal Other than 0 : Error (Refer to Item 17.1.3 for error codes.)
⑤ + 2	Local station usage channel	Specify the channel used by the local station. 1 to 8 (channel)
⑤ + 3	(Unused)	—
⑤ + 4	Target station network number	Specify the network number of the target station. 1 to 239 : Network number 254 : When 254 is specified for Jn. (Network specified in the valid module for remote station access)
⑤ + 5	Target station number	Specify the target station. (Refer to Item 14.4 "Precautions for data link commands.") 1 to 64 : Station number's station 81H to 89H : Group number's all stations (Can be set when the execution specified in ⑤ is "0 : type No delivery confirmation.") FFH : All stations on the target network number (simultaneous broadcast). (Can be set when the execution type specified in ⑤ is "0: No delivery confirmation.")
⑤ + 6	(Special function module station number)	Setting not necessary (Specification is valid when the command is executed from the special function module.)
⑤ + 7	Number of retries	Valid when the execution type specified in ⑤ is "1: Delivery confirmation." ① During command execution Set the number of retries for when transmission is not complete in the monitoring time specified in ⑤ +8. 0 to 15 (times) ② When command is complete The number of retries (result) is stored. 0 to 15 (times)
⑤ + 8	Delivery monitoring time	Valid when the execution type specified by ⑤ is "1: Delivery Confirmation." Set the monitoring time until command completion to a value greater than the TCP retransmit timer value. When the command is not complete within the monitoring time, the command execution is retransmit for the number of retransmit specified in ⑤ +7. 0 to TCP retransmit timer value : The TCP retransmit timer value is used as the monitoring time. (TCP retransmit timer value +1) to 16383 : Monitoring time (unit: second)
⑤ + 9	Write data length	Specify the number of write data for ⑤ +2 to ⑤ +n. 1 to 480 (words)
⑤ + 10	(Unused)	—
⑤ + 11	Clock set flag	Valid/invalid status of the data in ⑤ +12 to ⑤ +17 is stored. 0 : Invalid 1 : Valid

Control data details

Device	Item	Details
ⓈI+ 12	Year/month of error completion	The year (lower two digits) and month are stored in BCD code. <div style="border: 1px solid black; padding: 2px; width: fit-content; margin: 5px auto;"> b15 to b8 b7 to b0 <div style="display: flex; justify-content: space-around; width: 100%;"> Month (01H to 12H) Year (00H to 99H) </div> </div>
ⓈI+ 13	Day/hour of error completion	The day and hour are stored in BCD code. <div style="border: 1px solid black; padding: 2px; width: fit-content; margin: 5px auto;"> b15 to b8 b7 to b0 <div style="display: flex; justify-content: space-around; width: 100%;"> Hour (00H to 23H) Day (01H to 31H) </div> </div>
ⓈI+ 14	Minute/second of error completion	The minute and second are stored in BCD code. <div style="border: 1px solid black; padding: 2px; width: fit-content; margin: 5px auto;"> b15 to b8 b7 to b0 <div style="display: flex; justify-content: space-around; width: 100%;"> Second (00H to 59H) Minute (00H to 59H) </div> </div>
ⓈI+ 15	Day of the week of error completion	The day of the week is stored in BCD code. <div style="border: 1px solid black; padding: 2px; width: fit-content; margin: 5px auto;"> b15 to b8 b7 to b0 <div style="display: flex; justify-content: space-around; width: 100%;"> 00H Day of week (00H to 06H) 00H (Sunday) to 06H (Saturday) </div> </div>
ⓈI+ 16	Error detected network number	The network number of the station where the error was detected is stored.*1 1 to 239 (Network number)
ⓈI+ 17	Error detected station number	The station number where the error was detected is stored.*1 1 to 64 (Station number)

* 1 The number is not stored when the module that executes the command detected an error at acceptance of the command.

Point

- (1) To increase the data reliability, it is recommended to execute the command with “delivery confirmation” as the execution type when the target station number is specified within 1 to 64. When the target station number is specified within 81H to 89H or FFH, execute the command with the execution type as “no delivery confirmation.”
 - (2) When performing a device write from multiple stations to the same station, make sure that the write timing do not overlap.
 When the execution type is set to “no delivery confirmation,” even if the contents of the sent data is erroneous, the write origin station completes the process normally if the communication completes normally.
 Even if the contents of the transmission is normal, if the command is executed from multiple stations to the same station, the write origin station becomes time out error (C083H).
 - (3) The write data storage device (Ⓢ2, Ⓢ1) requires a continuous area (max. 480 words) for the write data length (ⓈI+ 9).
 - (4) When writing data from the other station CPU module device with the WRITE, SWRITE commands, specify the device within the range applicable to the host station CPU module.
 (Head device number to be write in other station CPU module (Ⓢ2)) + (number of write points -1) ≤ (last device number of host station CPU module*)
- *: Last device number in host station CPU module having the same device name as (Ⓢ2).

2 Command execution timing

(a) When normal completion

1) READ command

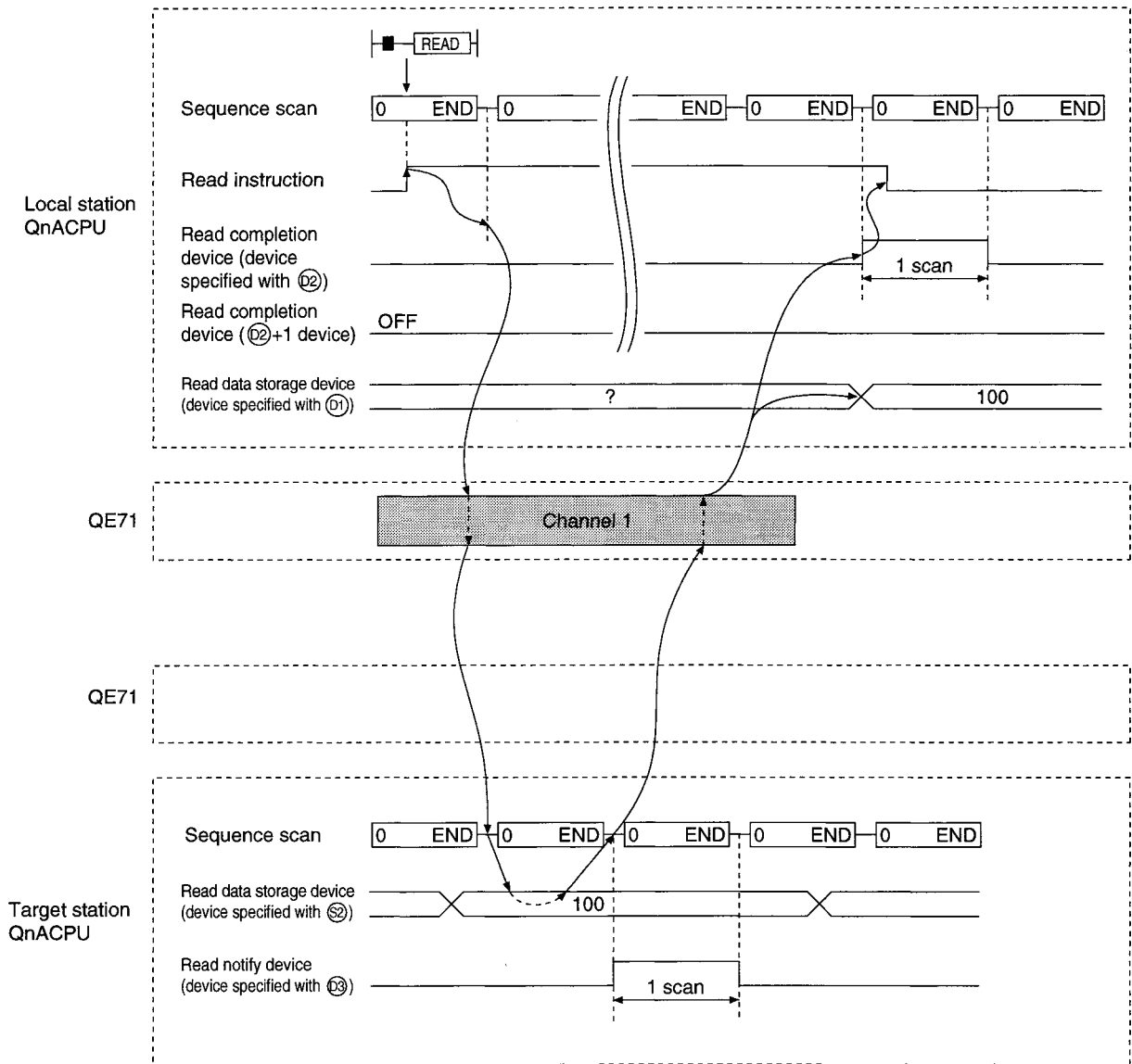

(b) WRITE command

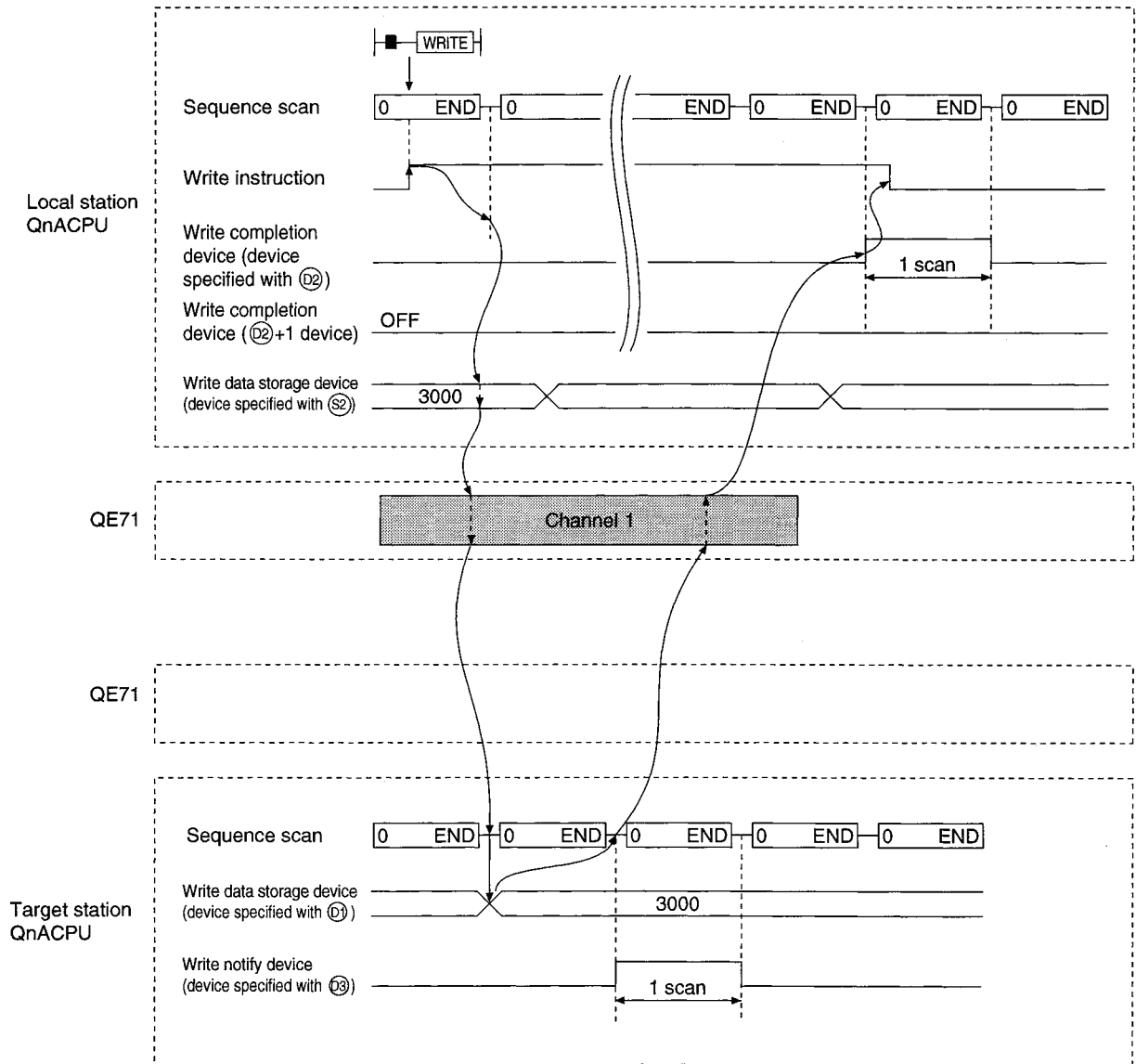

- (b) When error completion
- 1) READ command

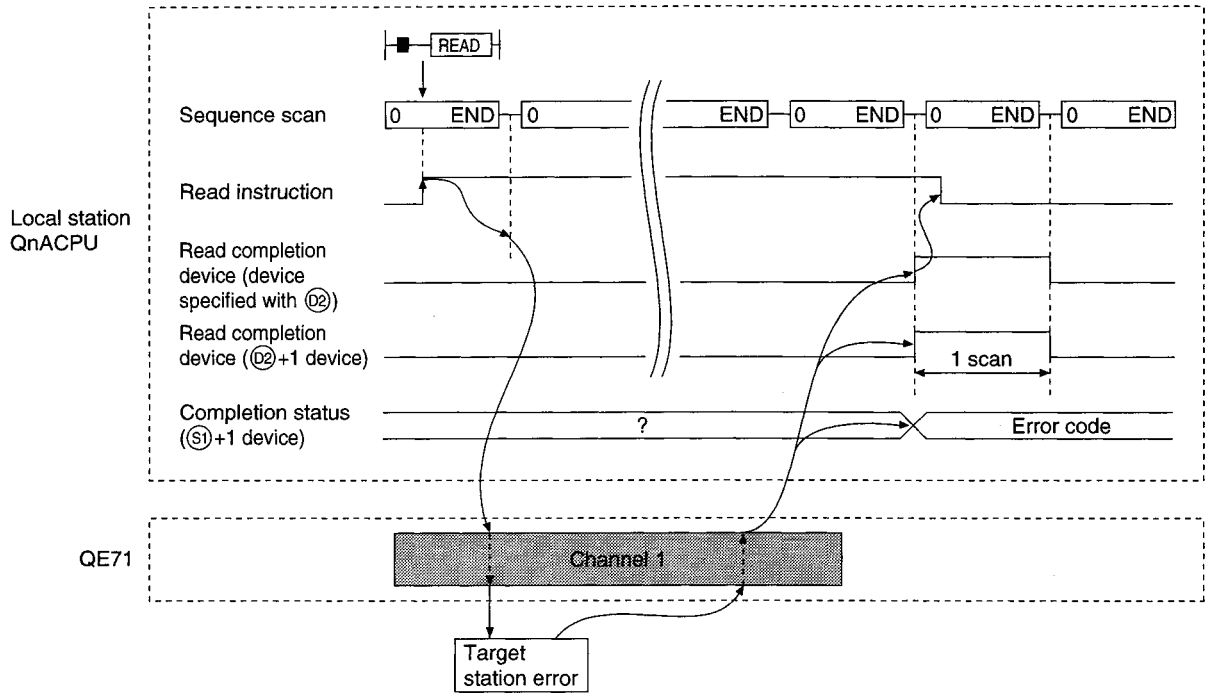

- 2) WRITE command

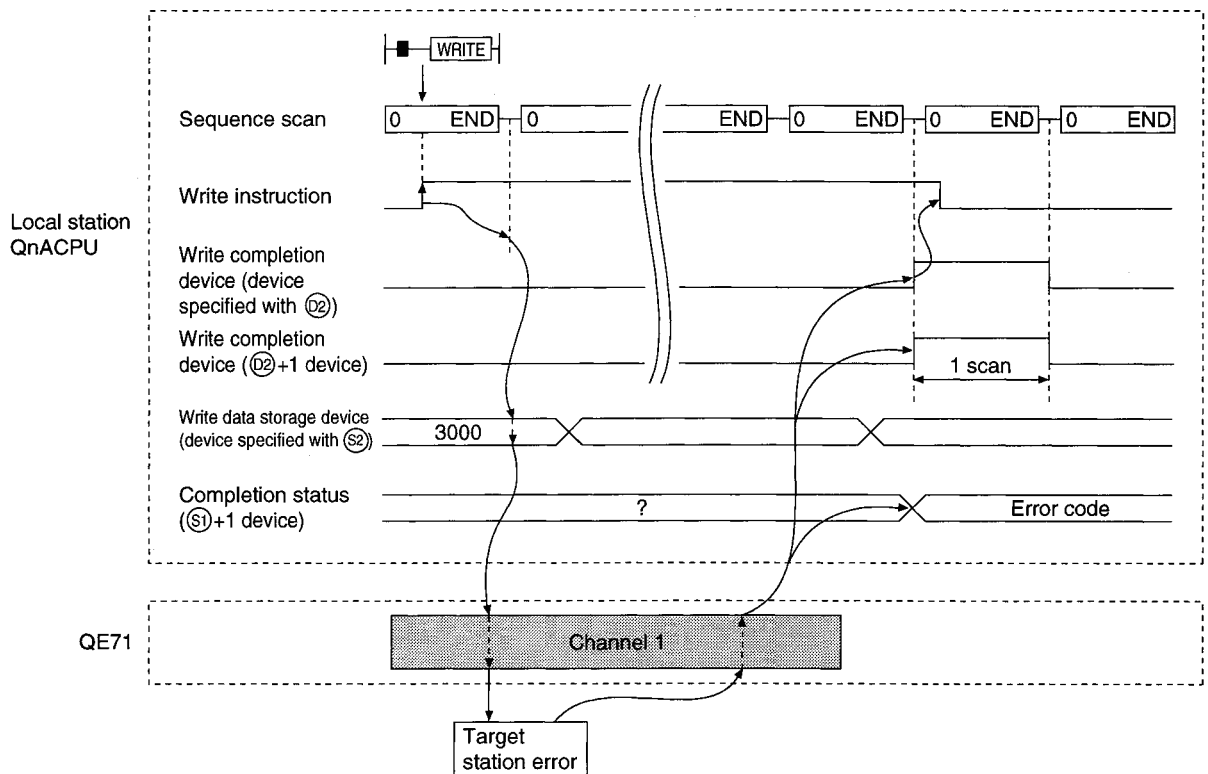

(3) Program example

Read data from D10 to 14 of station 4 to D200 to 204 of station 1.

Write the data stored in D300 to 303 of station 2 to D50 to 53 of station 3.

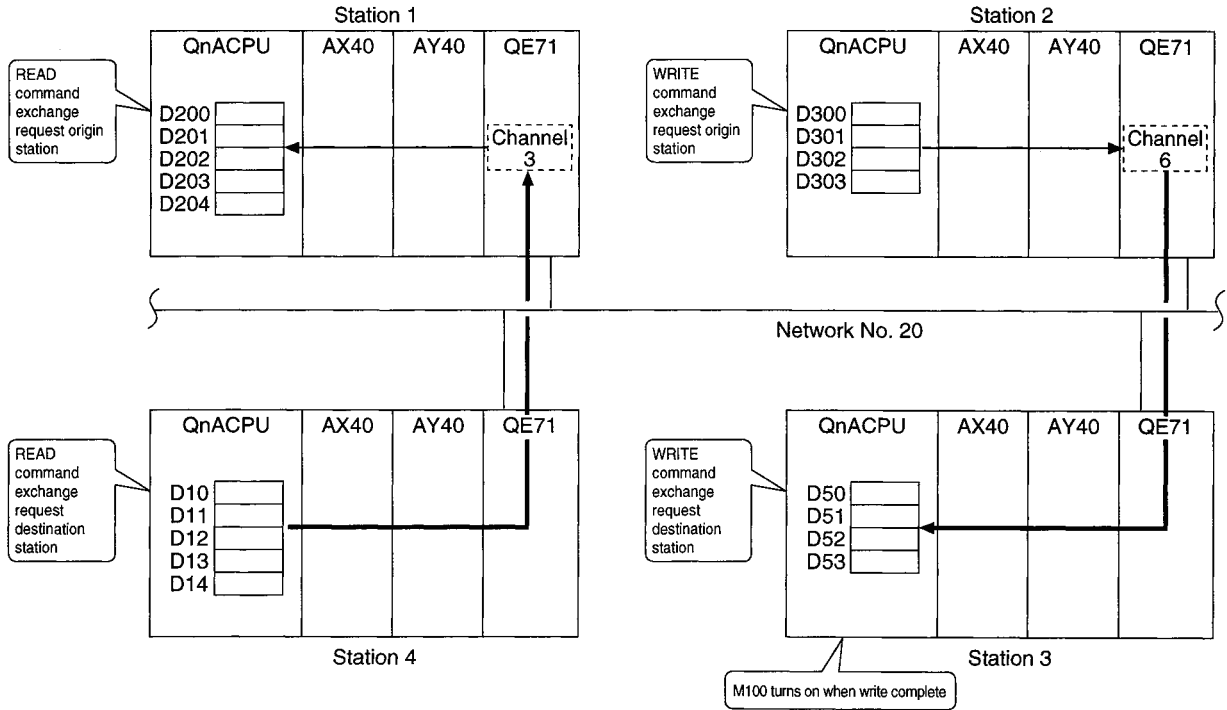

(a) Station 1 program (READ command)

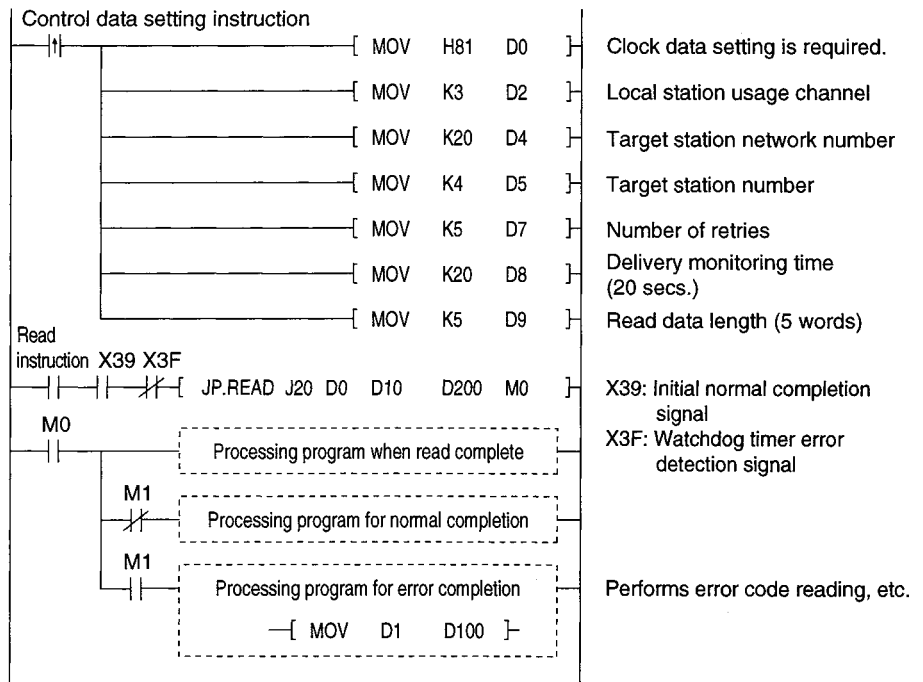

(b) Station 2 program (WRITE command)

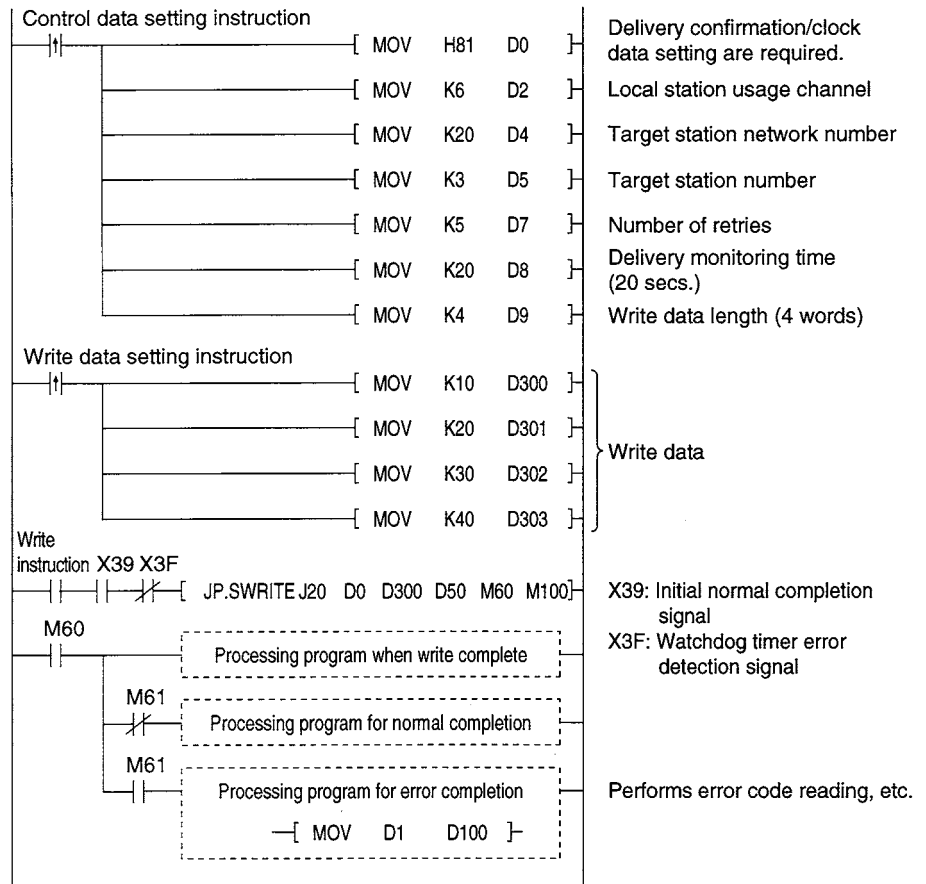

14.4.3 Read/Write Word Device of Remote Stations (ZNRD/ZNWR)

The command format and program example of the ZNRD/ZNWR commands are described.

1 Command format

(a) ZNRD command

[Network number specification]

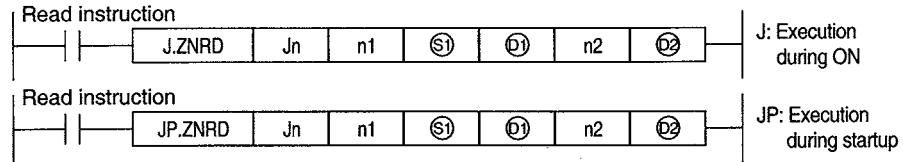

	Setting details	Setting range
Jn	Target station network number Specify the target station network number.	1 to 239
n1	Target station number Specify the station number of the target station.	1 to 64 (constant) Bit device digit specification*2 Word device*3
S1	Read data storage head device (target station) Specify the head device of the target station where the data to be read is stored.	T, C, D, W
D1	Read data storage head device (local station) Specify the head device of the local station which will store the data read.	Word device*3
n2	Read data length Specify the number of data (words) to read.	When reading from QnACPU 1 to 230 (constant) When reading from PLC CPU other than QnACPU*5 1 to 32 (constant) Bit device digit specification*2 Word device*3
D2	Read completion device (local station) Specify the device of the local station to turn on one scan when the read is complete. D2OFF: Incomplete ON: Complete D2 + 1OFF: Normal ON: Error	Bit device*1 Word device bit specification*4

*1: Bit device X, Y, M, L, F, V, B

*2: Bit device digit specification K [digit number] [Bit device head number]

*3: Word device T, C, D, W, ST, R, ZR

*4: Word device bit specification [Word device] . [Bit number]

*5: QnACPU via MELSECNET (II), MELSECNET/B is included.

Point

(1) The ZNRD command can be executed when the target station is the QnACPU. Access to the AnUCPU can be made via MELSECNET/10.

(2) When reading data from the other station CPU module device with the ZNRD command, specify the device within the range applicable to the host station CPU module.
 (Head device number to be read in other station CPU module (S1)) + (number of read points -1) < (last device number of host station CPU module*)

*: Last device number in host station CPU module having the same device name as (S1).

(3) The normal/error completion status when a read is complete is stored in the data link command exchange completion result (channel 1) storage area (address: 207) in the buffer memory. When the read completion device (Q2 + 1) is on due to error completion, read the error code (refer to Item 17.1.3) stored in the area mentioned above, and perform the necessary corrective action.

(b) ZNWR command
 [Network number specification]

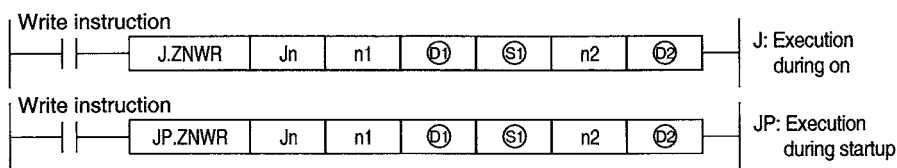

	Setting details	Setting range
Jn	Target station network number Specify the target station network number.	1 to 239
n1	Target station number Specify the target station's station number.	1 to 64 (constant) : Stations of station number 81H to 89H : All stations of group number FFH : All stations on the target network number Bit device digit specification*2 Word device*3
D1	Write data storage head device (target station) Specify the head device of the target station where the data to be written is stored.	T, C, D, W
S1	Write data storage head device (local station) Specify the head device of the local station which will store the data to be written.	Word device*3
n2	Write data length Specify the number of data (words) to write.	When writing from QnACPU 1 to 230 (constant) When writing from PLC CPU other than QnACPU*5 1 to 32 (constant) Bit device digit specification*2 Word device*3
Q2	Write completion device (local station) Specify the device of the local station to turn on one scan when the write is complete. Q2OFF: Incomplete ON: Complete Q2 + 1OFF: Normal ON: Error	Bit device*1 Word device bit specification*4

*1: Bit device X, Y, M, L, F, V, B
 *2: Bit device digit specification K [digit number] [Bit device head number]
 *3: Word device T, C, D, W, ST, R, ZR
 *4: Word device bit specification [Word device] [Bit number]
 *5: QnACPU via MELSECNET (II), MELSECNET/B is included.

Point

- (1) The ZNRD command can be executed when the target station is the QnACPU. Access to the AnUCPU can be made via MELSECNET/10.
- (2) When writing data from the other station CPU module device with the ZNRD command, specify the device within the range applicable to the host station CPU module.
 (Head device number to be write in other station CPU module (S)) + (number of write points - 1) (last device number of host station CPU module*)
 *: Last device number in host station CPU module having the same device name as (S).
- (3) The normal/error completion status when a write is complete is stored in the data link command exchange completion result (channel 2) storage area (address: 209) in the buffer memory. When the write completion device (D2 + 1) is on due to error completion, read the error code (refer to Item 17.1.3) stored in the area described above, and perform the necessary corrective action.

2 Command execution timing

- (a) When normal completion
 - 1) ZNRD command

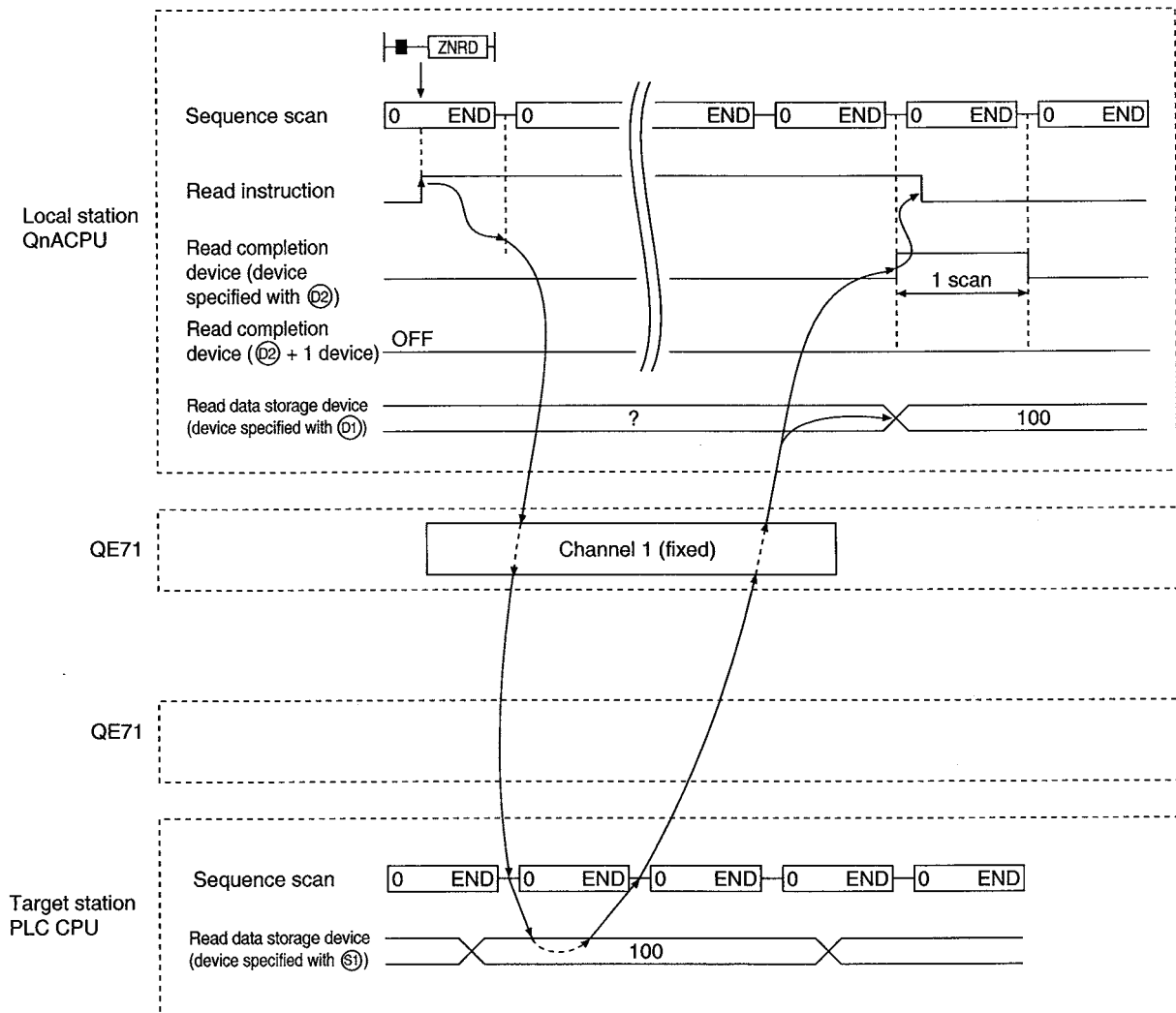

2) ZNWR command

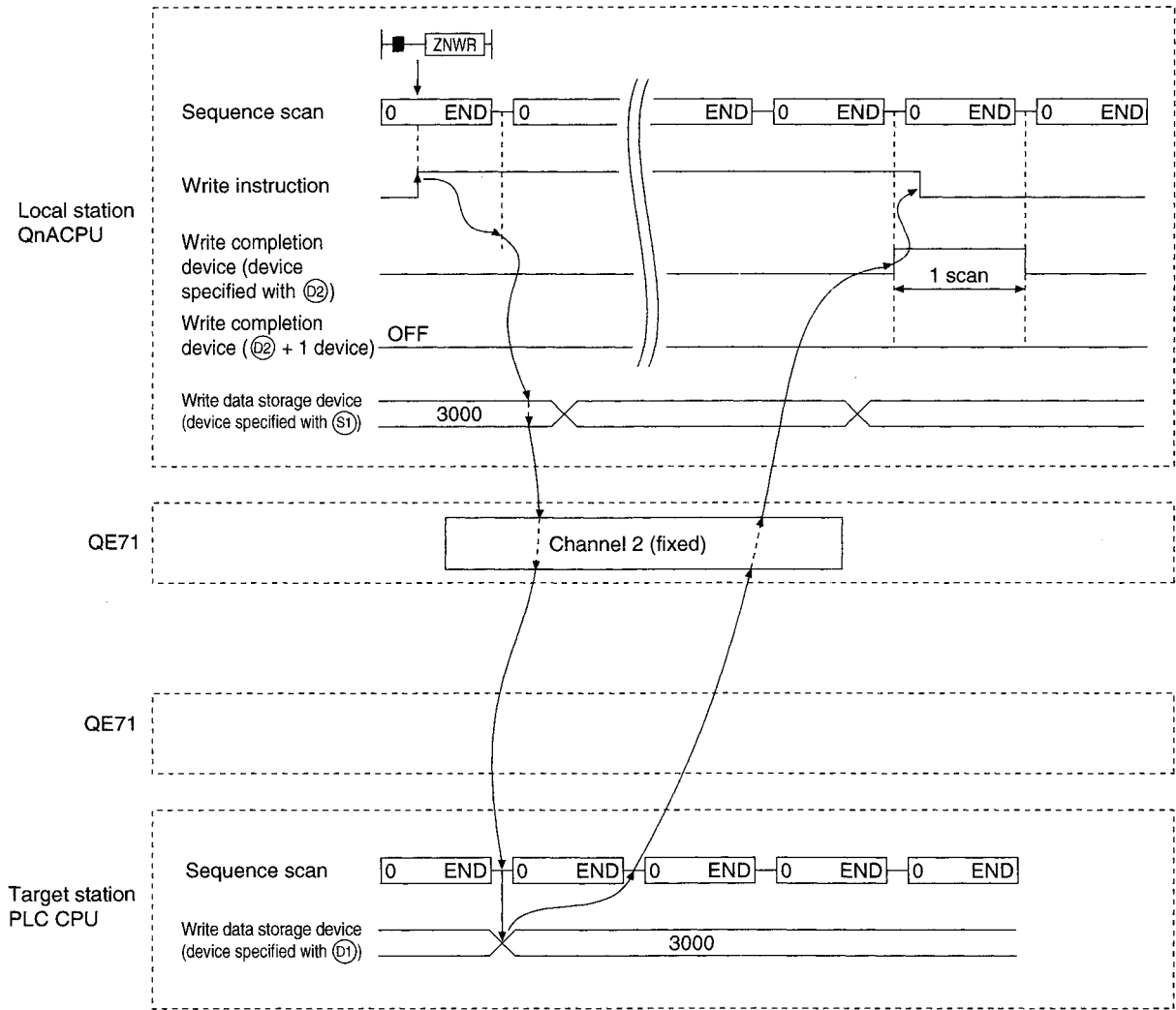

(b) When abnormal completion

1) ZNRD command

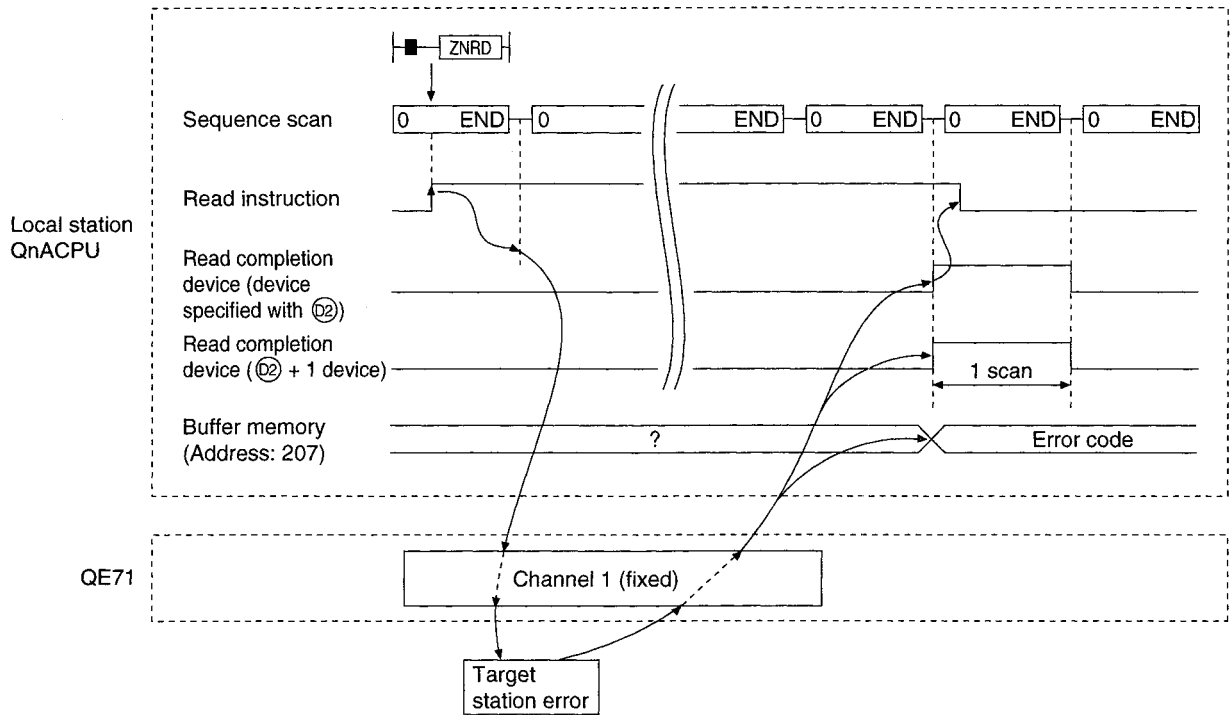

2) ZNWR command

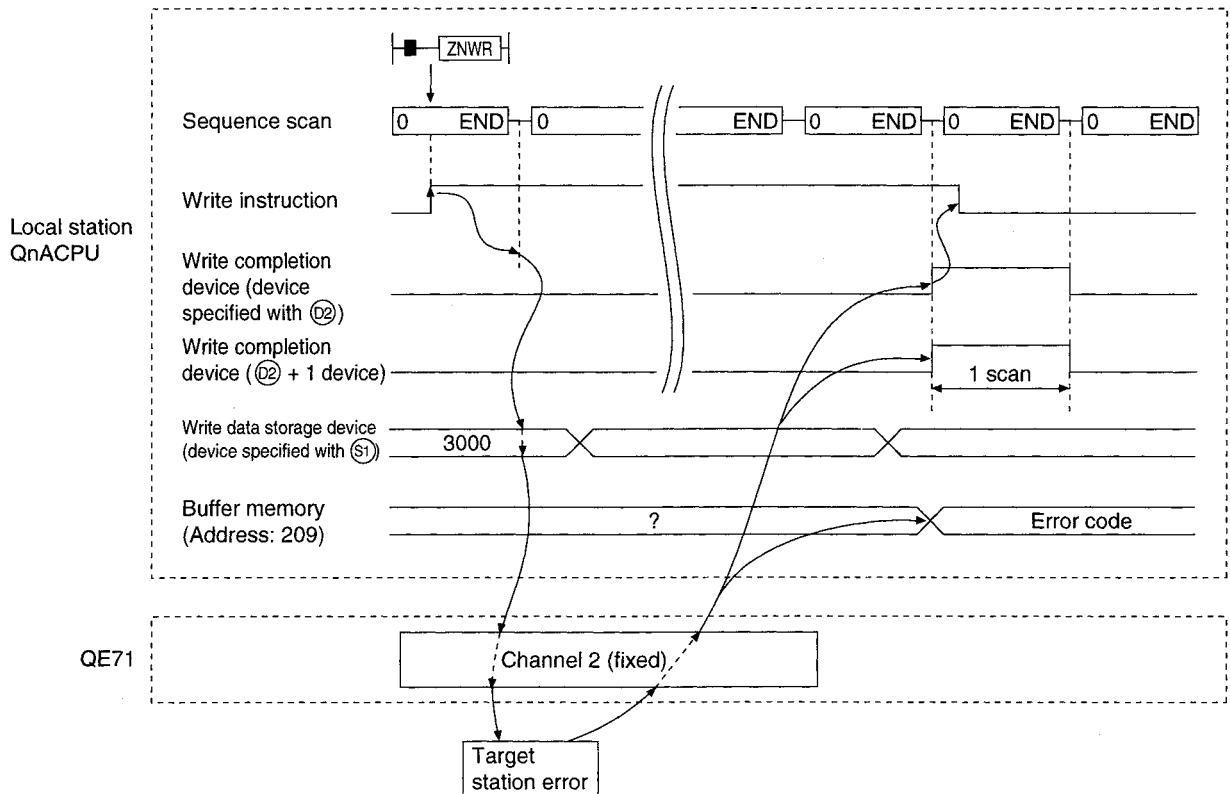

14.4.4 QnACPU Status Control

The command format and program example of the REQ command when conducting remote station QnACPU's status control (remote RUN/STOP) is described.

1 Command format

[Network number specification]

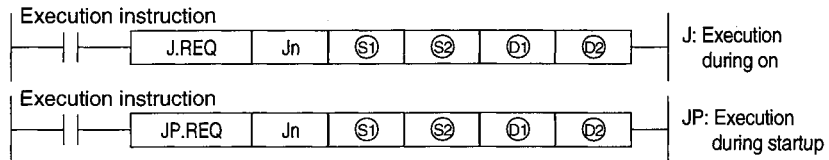

[Network module/QE71 head I/O number specification]

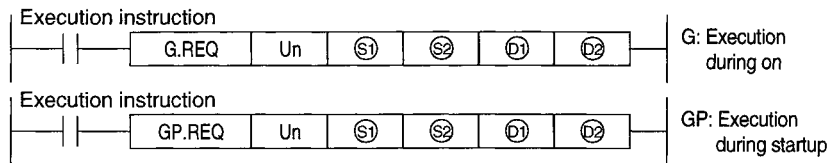

	Setting details	Setting range
Jn	Local station network number	1 to 239: Network number 254: Network specified in the valid module for remote station access.
Un	Local station network module/QE71 head I/O number Specify with two upper digits of the three-digit I/O number.	0 to FE _H
S1	Control data storage head device Specify the head device of the local station where the control data is stored.	Word device*2
S2	Request data storage head device (local station) Specify the head device of the local station where the request data is stored.	Word device*2
D1	Response data storage head device (local station) Specify the head device of the local station where the response data is stored.	Word device*2
D2	Execution completion device (local station) Specify the device of the local station to turn on one scan when the execution is complete. D2 OFF: Incomplete ON: Complete D2 + 1 OFF: Normal ON: Error	Bit device*1 Word device bit specification*3

*1: Bit device X, Y, M, L, F, V, B

*2: Word device T, C, D, W, ST, R, ZR

*3: Word device bit specification [Word device] . [Bit number]

The sequence and contents of the request data (S2) and response data (D1) varies depending on the request contents in the REQ instruction.

Refer to the Items 14.4.5 and 14.4.6 regarding the sequence and contents of the request data and response data for clock data read/write and EEPROM data read/write.

[Control data structure $\text{\textcircled{S}}$]

Device	Item	Data set	
		User (when executing)*1	System (when complete)*2
$\text{\textcircled{S}}$	Error completion type	○	
$\text{\textcircled{S}} + 1$	Completion status		○
$\text{\textcircled{S}} + 2$	Local station usage channel	○	
$\text{\textcircled{S}} + 3$	(Target station I/O number)		
$\text{\textcircled{S}} + 4$	Target station network number	○	
$\text{\textcircled{S}} + 5$	Target station number	○	
$\text{\textcircled{S}} + 6$	(Special function module station number)		
$\text{\textcircled{S}} + 7$	Number of retries	○	○
$\text{\textcircled{S}} + 8$	Delivery monitoring time	○	
$\text{\textcircled{S}} + 9$	Request data length	○	
$\text{\textcircled{S}} + 10$	Response data length		○
$\text{\textcircled{S}} + 11$	Clock set flag		○
$\text{\textcircled{S}} + 12$	Year/month of error completion		○
$\text{\textcircled{S}} + 13$	Day/hour of error completion		○
$\text{\textcircled{S}} + 14$	Minute/second of error completion		○
$\text{\textcircled{S}} + 15$	Day of the week of error completion		○
$\text{\textcircled{S}} + 16$	Error detected network number		○
$\text{\textcircled{S}} + 17$	Error detected station number		○

Used when the error completion type is set to "clock data setting is required."

*1: Item set by sequence program

*2: Item stored when command execution is complete

Control data details

Device	Item	Details														
$\text{\textcircled{S}}$	Error completion type	<table border="1" style="margin-left: 20px;"> <tr> <td>b15</td><td>to</td><td>b7</td><td>to</td><td>b4</td><td>to</td><td>b0</td> </tr> <tr> <td>0</td><td></td><td>$\text{\textcircled{2}}$</td><td>0</td><td>$\text{\textcircled{1}}$</td><td>0</td><td>1</td> </tr> </table> <p>① Processing request type (bit 4) Set depending on processing request contents. 0: EEPROM data read/write 1: QnACPU status control (remote RUN/STOP), clock data read/write</p> <p>② Error completion type (bit 7) Set the requirement/no-requirement of the clock data setting for error completion. 0: Clock data setting is not required ... Clock data is not set when error occurs in $\text{\textcircled{S}} + 11$ to $\text{\textcircled{S}} + 17$. 1: Clock data setting is required Clock data is set when error occurs in $\text{\textcircled{S}} + 11$ to $\text{\textcircled{S}} + 17$.</p>	b15	to	b7	to	b4	to	b0	0		$\text{\textcircled{2}}$	0	$\text{\textcircled{1}}$	0	1
b15	to	b7	to	b4	to	b0										
0		$\text{\textcircled{2}}$	0	$\text{\textcircled{1}}$	0	1										
$\text{\textcircled{S}} + 1$	Completion status	The command completion status is stored. 0 : Normal Other than 0 : Error (Refer to Item 17.1.3 for error codes.)														
$\text{\textcircled{S}} + 2$	Local station usage channel	Specify the channel used by the local station. 1 to 8 (channels)														
$\text{\textcircled{S}} + 3$	(Target station I/O number)	3FFH: Fixed value														
$\text{\textcircled{S}} + 4$	Target station network number	Specify the network number of the target station. 1 to 239 : Network number 254 : When 254 is specified by Jn (Network specified in the valid module for remote station access).														

Control data details

Device	Item	Details		
Ⓢi + 5	Target station number	Specify the target station (Refer to Item 14.4 "Precautions for data link commands"). 1 to 64 : Station number's station 81H to 89H: Group number's all station (Only clock data write and remote RUN/STOP can be executed.) FFH : All stations on the target network number (simultaneous broadcast) (Only clock data write and remote RUN/STOP can be executed.)		
Ⓢi + 6	(Special function module station number)	Setting not necessary (Specification is valid when the instruction is executed from the special function module.)		
Ⓢi + 7	Number of retries	① During command execution Set the number of retries for when transmission is not complete in the monitoring time specified in Ⓢi + 8. 0 to 15 (times) ② When command is complete The number of retries (result) is stored. 0 to 15 (times)		
Ⓢi + 8	Delivery monitoring time	Set the monitoring time until command completion to a value greater than the TCP retransmit timer value. When the command is not complete within the monitoring time, the command execution is retransmit for the number of retransmit specified in Ⓢi + 7. 0 to TCP retransmit timer value : The TCP retransmit timer value is used as the monitoring time. (TCP retransmit timer value +1) to 16383 : Monitoring time (unit: second)		
Ⓢi + 9	Request data length	Specify the number of request data (words). (Number of words for the data to be stored in the request data storage device Ⓢ.) 4 : Remote RUN 4 : Remote STOP 2 : Read clock data 6 : Write clock data 4 : Read EEPROM data 4 + write data length : Write EEPROM data		
Ⓢi + 10	Response data length	Number of response data (words) is stored. (Number of words for the data to be stored in the response data storage device Ⓢ.) QnACPU remote RUN/STOP 2 : Remote RUN/STOP 6 : Read clock data 2 : Write clock data 3 to 482 : Read EEPROM data 2 : Write EEPROM data		
Ⓢi + 11	Clock set flag	Valid/invalid status of the data in Ⓢi + 12 to Ⓢi + 17 is stored. 0 : Invalid 1 : Valid		
Ⓢi + 12	Year/month of error completion	The year (lower two digits) and month are stored in BCD code. b15 to b8 b7 to b0 <table border="1" style="margin-left: auto; margin-right: auto;"> <tr> <td style="text-align: center;">Month (01H to 12H)</td> <td style="text-align: center;">Year (00H to 99H)</td> </tr> </table>	Month (01H to 12H)	Year (00H to 99H)
Month (01H to 12H)	Year (00H to 99H)			
Ⓢi + 13	Day/hour of error completion	The day and hour are stored in BCD code. b15 to b8 b7 to b0 <table border="1" style="margin-left: auto; margin-right: auto;"> <tr> <td style="text-align: center;">Hour (00H to 23H)</td> <td style="text-align: center;">Day (01H to 31H)</td> </tr> </table>	Hour (00H to 23H)	Day (01H to 31H)
Hour (00H to 23H)	Day (01H to 31H)			
Ⓢi + 14	Minute/second of error completion	The minute and seconds are stored in BCD code. b15 to b8 b7 to b0 <table border="1" style="margin-left: auto; margin-right: auto;"> <tr> <td style="text-align: center;">Second (00H to 59H)</td> <td style="text-align: center;">Minute (00H to 59H)</td> </tr> </table>	Second (00H to 59H)	Minute (00H to 59H)
Second (00H to 59H)	Minute (00H to 59H)			
Ⓢi + 15	Day of the week of error completion	The day of the week is stored in BCD code. b15 to b8 b7 to b0 <table border="1" style="margin-left: auto; margin-right: auto;"> <tr> <td style="text-align: center;">00H</td> <td style="text-align: center;">Day of week (00H to 06H)</td> </tr> </table> 00H (Sunday) to 06H (Saturday)	00H	Day of week (00H to 06H)
00H	Day of week (00H to 06H)			
Ⓢi + 16	Error detected network number	The network number of the station where the error was detected is stored.*1 1 to 239 (Network number)		
Ⓢi + 17	Error detected station number	The station number where the error was detected is stored.*1 1 to 64 (Station number)		

* 1 The number is not stored when the module that executes the command detected an error at acceptance of the command.

[Request data ⑳ and response data ㉑ at remote RUN/STOP]

1) Request data

Device	Item	Details	Remote RUN	Remote STOP
⑳	Request type	0010H: When station number is specified by ㉑+5 0030H: When all stations or group is specified by ㉑+5	○	○
⑳ + 1	Subrequest type	0001H: Remote RUN 0002H: Remote STOP	○	○
⑳ + 2	Mode	Specifies whether the remote RUN/STOP is executed forcefully. 0001H: No force execution 0003H: Force execution (setting for remote STOP) (The forceful execution allows a forceful remote RUN from another station when the station that performed the remote STOP cannot perform remote RUN.)	○	○
⑳ + 3	Clear mode	Specifies the QnACPU device memory status when only the remote RUN is performed. 0000H: Do not clear 0001H: Clear (excludes setting for remote RUN and latch range) 0002H: Clear (includes setting for remote RUN and latch range)	○	○

2) Response data

Device	Item	Details	Remote RUN	Remote STOP
㉑	Request type	0090H: When station number is specified by ㉑+5 00B0H: When all stations or group is specified by ㉑+5	○	○
㉑ + 1	Subrequest type	0001H: Remote RUN 0002H: Remote STOP	○	○

Point

- (1) The remote RUN/STOP is valid when the target station QnACPU's RUN/STOP key switch is at "RUN".
- (2) Remote RUN/STOP cannot be performed when the target station QnACPU has system protect on (system protect switch SW5 is on).
- (3) When remote STOP/PAUSE has been set by another station for the target station, it cannot be set to RUN if the ⑳ + 2 mode is set to "no force execution (0001H)".
- (4) When the QnACPU of the remote RUN/STOP target station is reset, the remote RUN/STOP data is erased.
- (5) The clear mode (⑳ + 3) is used to specify the clearing (initialization) processing of the QnACPU device memory, when starting the QnACPU operations with remote RUN.
When the QnACPU performs a specified clear, the system runs according to the parameter settings (PLC file setting → device initialization values).

2 Command execution timing

(a) When normal completion

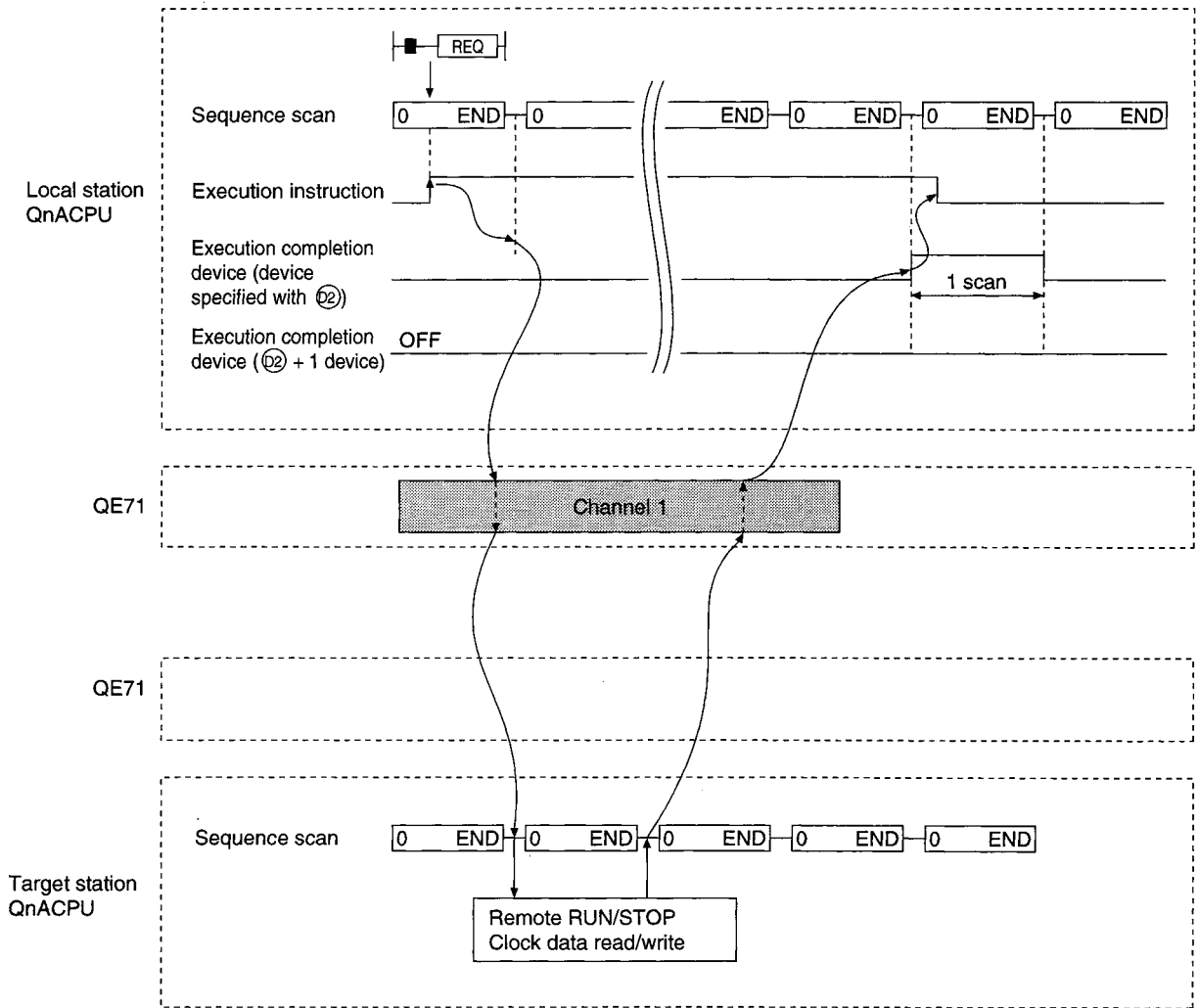

(b) When error completion

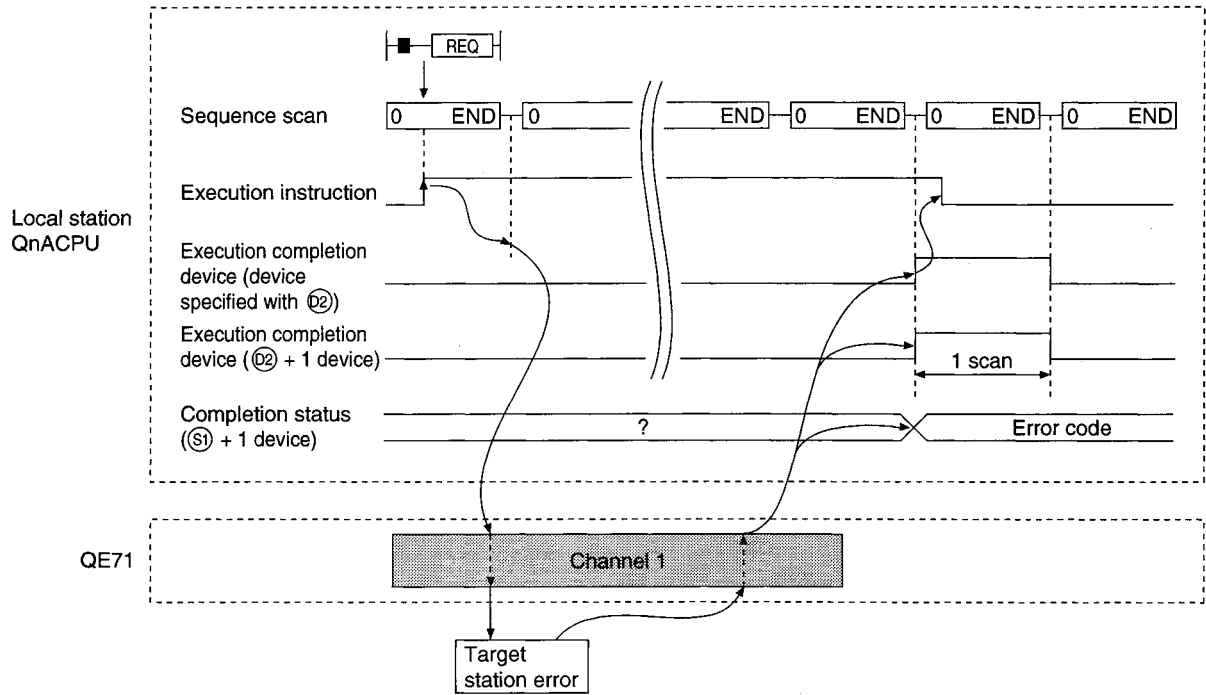

3 Program example

This is a program to "Remote STOP" station number 13 on network number 7.

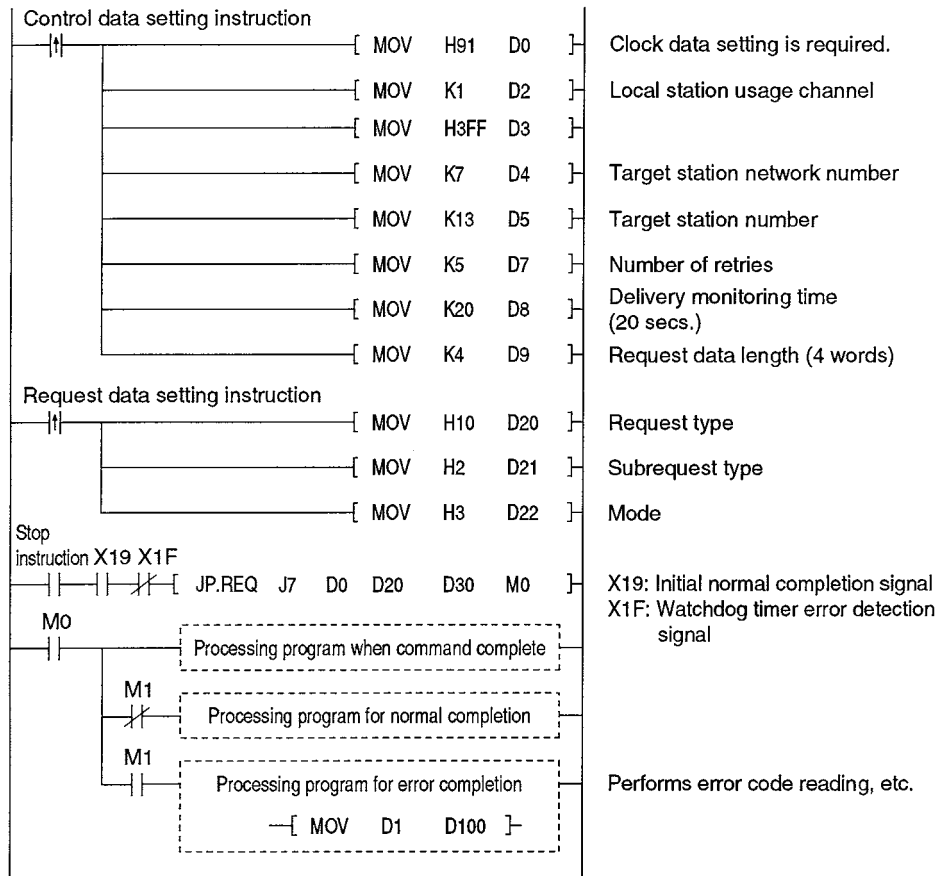
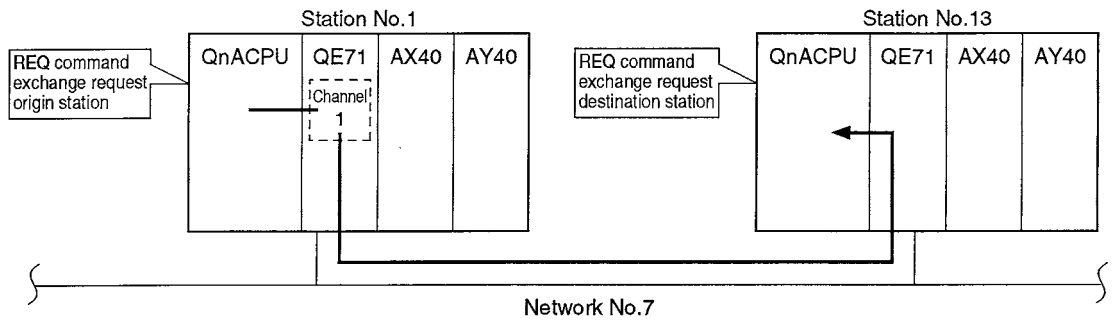

14.4.5 QnACPU Clock Data Read/Write (REQ)

The command format and program example of the REQ instructions when conducting remote station QnACPU's clock data read/write.

1 Command format

The request data and the response data are shown.

Refer to Item 14.4.4 regarding the command data sequence and control data execution completion device.

[Request data ② and response data ①] at clock data read/write]

1) Request data

Device	Item	Details	Read clock data	Write clock data																
②	Request type	0001H: Read clock data 0011H: Write clock data (When station number is specified by ⑥+5) 0031H: Write clock data (When all stations or group is specified by ⑥+5)	○	○																
② + 1	Subrequest type	0002H: Read clock data 0001H: Write clock data	○	○																
② + 2	Change pattern Year of change	① Change pattern (bit 0 to 7) Specifies which item in the clock data ② + 2 upper byte to ② + 5 to write. 0 : Do not change 1 : Change ② Year of change (bit 8 to 15) The year (lower two digits) are stored in BCD code. <div style="display: flex; align-items: center;"> <div style="margin-right: 10px;">b15 to b8</div> <table border="1" style="border-collapse: collapse; text-align: center;"> <tr> <td>b7</td><td>b6</td><td>b5</td><td>b4</td><td>b3</td><td>b2</td><td>b1</td><td>b0</td> </tr> <tr> <td colspan="2">Year (00H to 99H)</td> <td>0</td><td></td><td></td><td></td><td></td><td></td> </tr> </table> <div style="margin-left: 10px;"> <p>→ Year</p> <p>→ Month</p> <p>→ Day</p> <p>→ Hour</p> <p>→ Minute</p> <p>→ Second</p> <p>→ Day of week</p> </div> </div>	b7	b6	b5	b4	b3	b2	b1	b0	Year (00H to 99H)		0							○
b7	b6	b5	b4	b3	b2	b1	b0													
Year (00H to 99H)		0																		
② + 3	Month/day of change	The month and day are stored in BCD code. <div style="display: flex; align-items: center;"> <div style="margin-right: 10px;">b15 to b8</div> <table border="1" style="border-collapse: collapse; text-align: center;"> <tr> <td>b7 to b4</td><td>b3 to b0</td> </tr> <tr> <td>Day (01H to 31H)</td><td>Month (01H to 12H)</td> </tr> </table> </div>	b7 to b4	b3 to b0	Day (01H to 31H)	Month (01H to 12H)		○												
b7 to b4	b3 to b0																			
Day (01H to 31H)	Month (01H to 12H)																			
② + 4	Hour/minute of change	The hour and minute are stored in BCD code. <div style="display: flex; align-items: center;"> <div style="margin-right: 10px;">b15 to b8</div> <table border="1" style="border-collapse: collapse; text-align: center;"> <tr> <td>b7 to b4</td><td>b3 to b0</td> </tr> <tr> <td>Minute (00H to 59H)</td><td>Hour (00H to 23H)</td> </tr> </table> </div>	b7 to b4	b3 to b0	Minute (00H to 59H)	Hour (00H to 23H)		○												
b7 to b4	b3 to b0																			
Minute (00H to 59H)	Hour (00H to 23H)																			
② + 5	Second/day of the week of change	The second and day of the week are stored in BCD code. <div style="display: flex; align-items: center;"> <div style="margin-right: 10px;">b15 to b8</div> <table border="1" style="border-collapse: collapse; text-align: center;"> <tr> <td>b7 to b4</td><td>b3 to b0</td> </tr> <tr> <td>Day of week (00H to 06H)</td><td>Second (00H to 59H)</td> </tr> </table> <div style="margin-left: 10px;"> <p>→ 00H (Sunday) to 06H (Saturday)</p> </div> </div>	b7 to b4	b3 to b0	Day of week (00H to 06H)	Second (00H to 59H)		○												
b7 to b4	b3 to b0																			
Day of week (00H to 06H)	Second (00H to 59H)																			

2) Response data (Data is not stored which is the year to the day of week when writing clock data.)

Device	Item	Details	Read clock data	Write clock data												
(D)	Request type	0081H: Read clock data 0091H: Write clock data	○	○												
(D) + 1	Subrequest type	0002H: Read clock data 0001H: Write clock data	○	○												
(D) + 2	Month/year of change	The month and year (lower two digits) are stored in BCD code. <table border="1" style="margin-left: auto; margin-right: auto;"> <tr> <td style="text-align: center;">b15</td> <td style="text-align: center;">to</td> <td style="text-align: center;">b8</td> <td style="text-align: center;">b7</td> <td style="text-align: center;">to</td> <td style="text-align: center;">b0</td> </tr> <tr> <td colspan="3" style="text-align: center;">Month (01H to 12H)</td> <td colspan="3" style="text-align: center;">Year (00H to 99H)</td> </tr> </table>	b15	to	b8	b7	to	b0	Month (01H to 12H)			Year (00H to 99H)			○	
b15	to	b8	b7	to	b0											
Month (01H to 12H)			Year (00H to 99H)													
(D) + 3	Hour/day of change	The hour and day are stored in BCD code. <table border="1" style="margin-left: auto; margin-right: auto;"> <tr> <td style="text-align: center;">b15</td> <td style="text-align: center;">to</td> <td style="text-align: center;">b8</td> <td style="text-align: center;">b7</td> <td style="text-align: center;">to</td> <td style="text-align: center;">b0</td> </tr> <tr> <td colspan="3" style="text-align: center;">Hour (00H to 23H)</td> <td colspan="3" style="text-align: center;">Day (01H to 31H)</td> </tr> </table>	b15	to	b8	b7	to	b0	Hour (00H to 23H)			Day (01H to 31H)			○	
b15	to	b8	b7	to	b0											
Hour (00H to 23H)			Day (01H to 31H)													
(D) + 4	Second/minute of change	The second and minute are stored in BCD code. <table border="1" style="margin-left: auto; margin-right: auto;"> <tr> <td style="text-align: center;">b15</td> <td style="text-align: center;">to</td> <td style="text-align: center;">b8</td> <td style="text-align: center;">b7</td> <td style="text-align: center;">to</td> <td style="text-align: center;">b0</td> </tr> <tr> <td colspan="3" style="text-align: center;">Second (00H to 59H)</td> <td colspan="3" style="text-align: center;">Minute (00H to 59H)</td> </tr> </table>	b15	to	b8	b7	to	b0	Second (00H to 59H)			Minute (00H to 59H)			○	
b15	to	b8	b7	to	b0											
Second (00H to 59H)			Minute (00H to 59H)													
(D) + 5	Day of the week of change	The day of the week is stored in BCD code. <table border="1" style="margin-left: auto; margin-right: auto;"> <tr> <td style="text-align: center;">b15</td> <td style="text-align: center;">to</td> <td style="text-align: center;">b8</td> <td style="text-align: center;">b7</td> <td style="text-align: center;">to</td> <td style="text-align: center;">b0</td> </tr> <tr> <td colspan="3" style="text-align: center;">00H</td> <td colspan="3" style="text-align: center;">Day of week (00H to 06H)</td> </tr> </table> <p style="margin-left: 150px;">↘ 00H (Sunday) to 06H (Saturday)</p>	b15	to	b8	b7	to	b0	00H			Day of week (00H to 06H)			○	
b15	to	b8	b7	to	b0											
00H			Day of week (00H to 06H)													

Point

- (1) When the system protect is in effect for the target station QnACPU (system protect switch SW5 is on), clock data read/write cannot be performed.
- (2) When reading the clock data, 6 words of continuous area is required as a response data storage device (D).

2

Command execution timing

The command execution timing is the same as for the status control of the QnACPU. Refer to Item 14.4.4.

3 Program example

A program to write the clock data (8:30:00) to the QnACPU at station number 13 in network number 7.

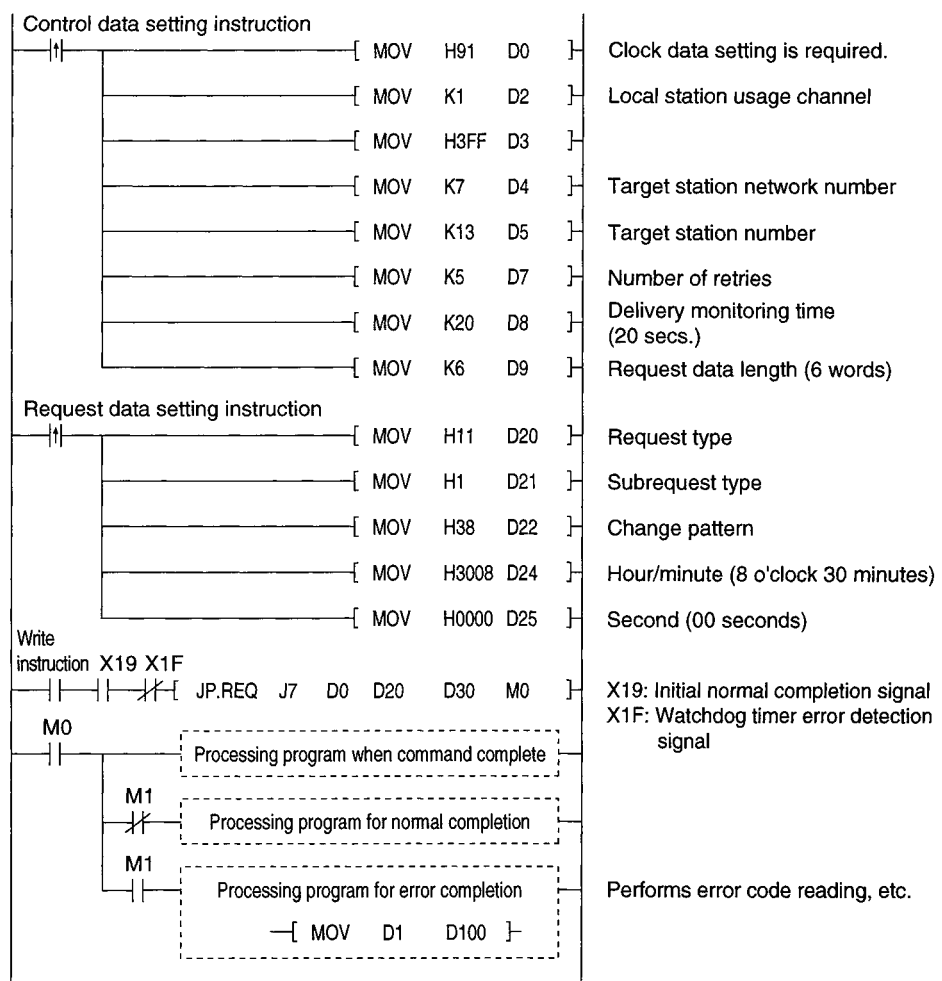
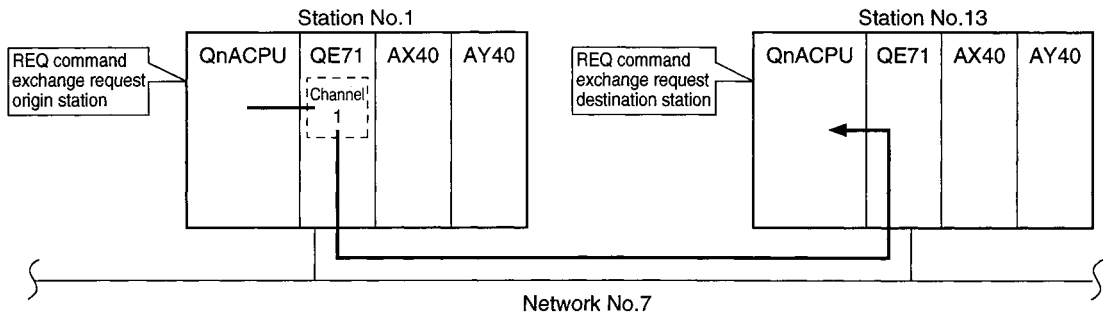

14.4.6 QE71 EEPROM Data Read/Write (REQ)

The command format and program example of the REQ command when conducting local station QE71 EEPROM data read/write (registration).

The EEPROM data read/write with a REQ command can only be performed to the local station QE71.

1 Command format

The request data and the response data are shown.

Refer to Item 14.4.4 regarding the command data sequence and control data execution completion device.

[Request data ② and response data ① at EEPROM data read/write]

1) Request data (Not necessary to specify the write data when reading EEPROM data.)

Device	Item	Details	Read EEPROM data	Write EEPROM data
②	Request type	0006H: Read EEPROM data 0016H: Write (register) EEPROM data	○	○
② + 1	Subrequest type	0011H: Read/write EEPROM data	○	○
② + 2	Head address	Specify the head address of the read/write data range in the EEPROM. * Specify the same address as the buffer memory address specified for the target data storage. 0 to 959: Head address	○	○
② + 3	Read/write data length	Specify the number of addresses (number of words) for the read/write data range. 1 to 480: Read/write data length	○	○
② + 4 to ② + 483	Write data	Specify the write data for the length of data to be written in the EEPROM. The order of the data to be specified is as follows: ② + 4 Data of the head address specified ② + 5 Head address + 1 ⋮ ⋮		○

2) Response data (Read data is not stored when writing EEPROM data.)

Device	Item	Details	Read EEPROM data	Write EEPROM data
①	Request type	0086H: Read EEPROM data 0096H: Write (register) EEPROM data	○	○
① + 1	Subrequest type	0011H: Read/write EEPROM data	○	○
① + 2 to ① + 481	Read data	When reading EEPROM data, the data for the length read is stored. The order of the storage is as follows: ① + 2 :Data of the head address specified ① + 3 :Head address + 1 ⋮ ⋮	○	

Point

- (1) A continuous area for the read data length $(S2 + 3) + 2$ is required as the response data storage device (D1) when reading EEPROM data.
- (2) Specify the data to write to the EEPROM according to the item describing the corresponding buffer memory in this manual.
- (3) EEPROM read can be performed only with data that is correctly written (registered). When a read is requested for an erroneous data, an error results.

2 Command execution timing

(a) When normal completion

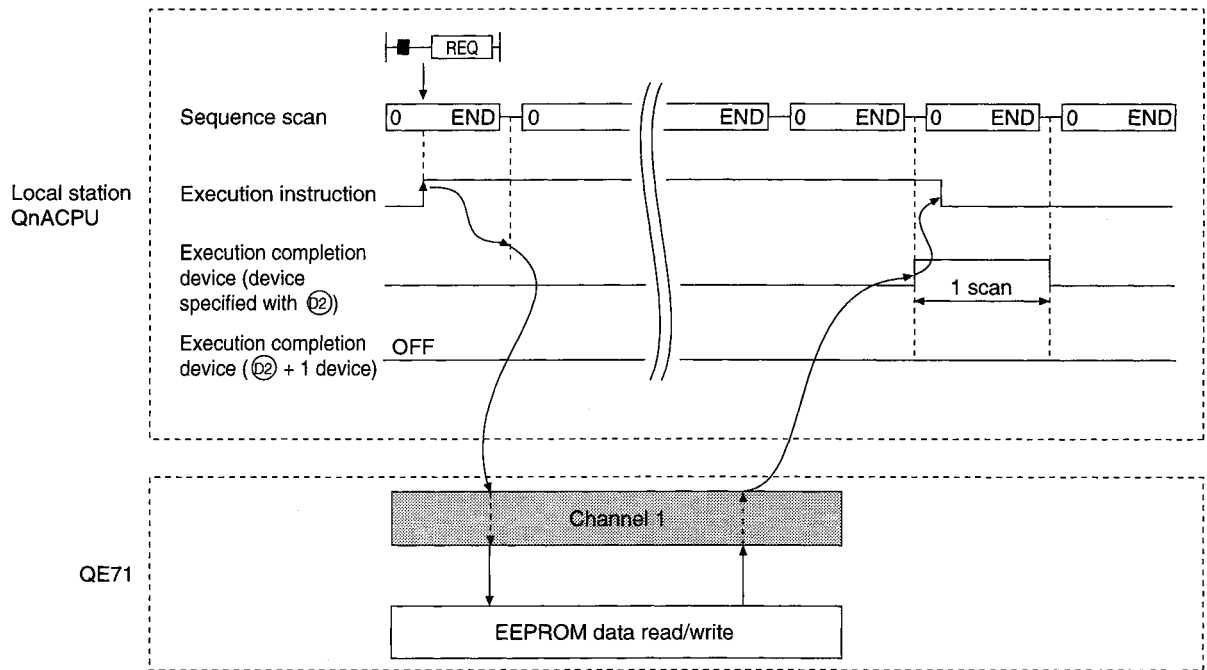

(b) When error completion

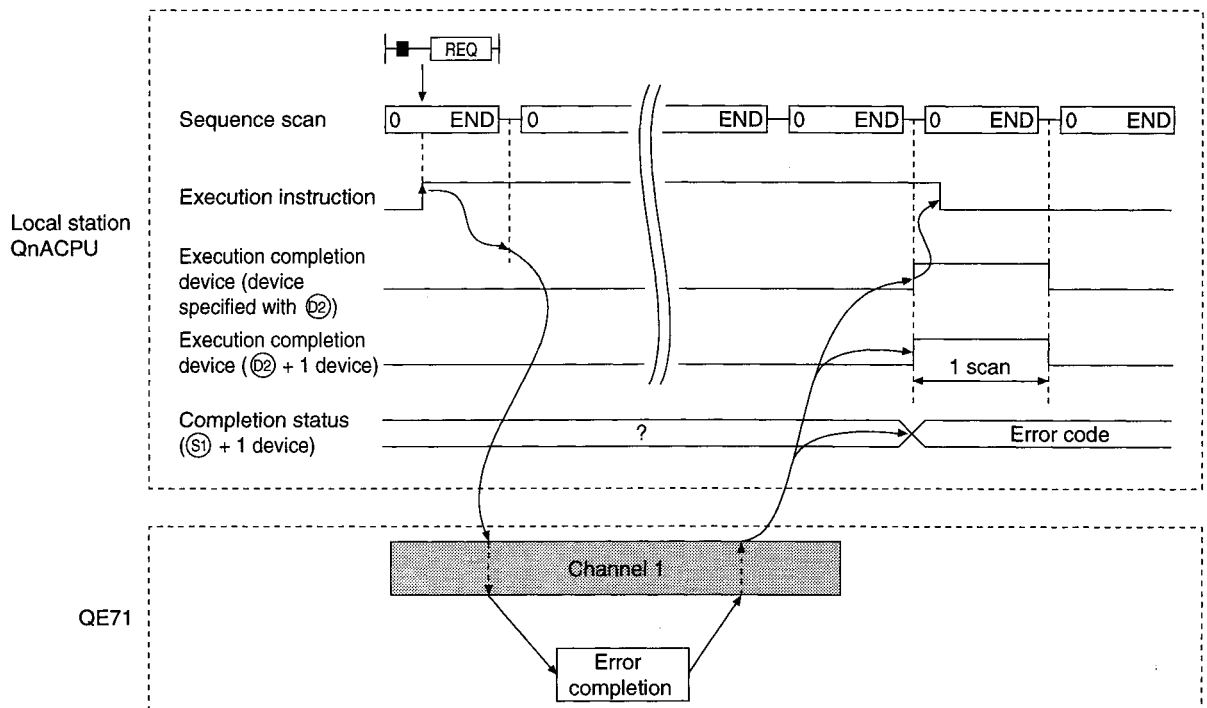

3 Program example

This is a program to read local station QE71's EEPROM data.

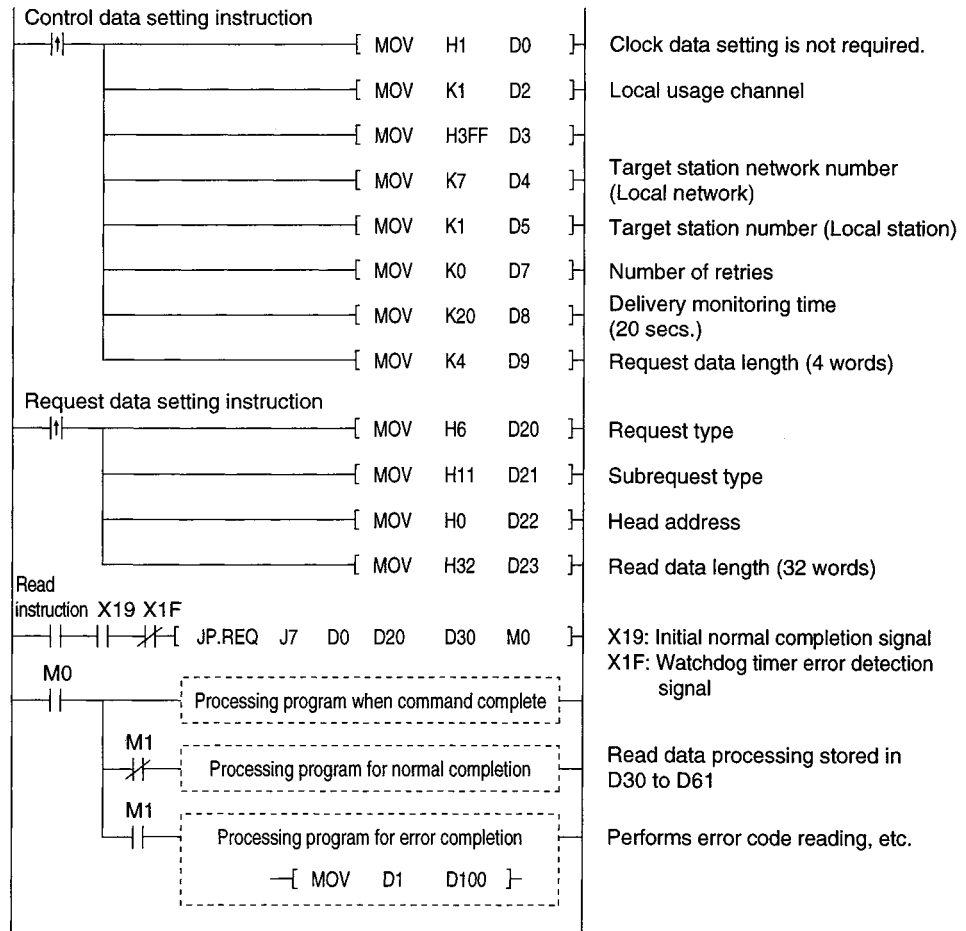

14.5 Error Codes for Data Link Commands

When the execution results of the data link command shown in this chapter error end, the returned error code is the same error code as is shown in Item 17.1.3, so 4000H to FFFFH codes are returned.

The error code for data link command is stored in the QE71 error log area and the following area:

- ① SEND, RECV, READ (SREAD), WRITE (SWRITE), REQ : Control data completion status (S1) + 1)
- ② ZNRD : Buffer memory (Address 207)
- ③ ZNWT : Buffer memory (Address 209)

15. WHEN EXCHANGING WITH MELSECNET/10 RELAY

The Ethernet network system can be in the same class as the MELSECNET/10 network system. Remote node or QE71 installed station QnACPU can give access to the remote stations via maximum 7 Ethernet networks and MELSECNET/10 within the MELSECNET/10 specification range.

In this chapter, the MELSECNET/10 relay exchange functions are described, to perform data exchange with remote station PLC CPUs via Ethernet or MELSECNET/10 from the QnACPU at remote node or QE71 installed station using the QE71.

Point

- (1) The remote station access using the MELSECNET/10 relay exchange function can be performed if local station QnACPU is the product shown in Item 2.5.3.
- (2) When the data exchange is performed in the network indicated with dotted lines in the diagram in Item 15.2, perform the remote station access stated in this chapter.
- (3) Set the required parameters according to Item 4.8 and 15.3 when performing remote station access via Ethernet when connecting a GPPW to the QnACPU.

15.1 MELSECNET/10 Relay Exchange

The MELSECNET/10 relay exchange is a function to perform the following data exchange to the remote station PLC via Ethernet or MELSECNET/10 from the remote node or QE71 installed QnACPU station using the QE71.

The message for the MELSECNET/10 relay exchange function through QE71 is created by the QE71 which received the exchange request.

If the user performs the exchange request with the message format and exchange method described in the corresponding function description item, the remote station access becomes possible with the MELSECNET/10 relay exchange function.

Function that can perform exchange	Remote station access	Exchange request origin	Item which describes the function
Read/write data in another station's PLC CPU with the QE71 command (Including the access from GPPW to another station's PLC CPU)	<ul style="list-style-type: none"> • When using this relay exchange function, access is possible to the PLC CPU on remote Ethernet via MELSECNET/10. • When this relay exchange function is not used, access is possible only for the same Ethernet and MELSECNET. Remote station access to stations on remote Ethernet via MELSECNET/10 is not possible.	Remote node	Chapter 9 Chapter 10
		GPPW	Mannual for GPPW
Access the remote station PLC CPU with the data link command	<ul style="list-style-type: none"> • When using this relay exchange function, access is possible to the PLC CPU via Ethernet and MELSECNET/10. • When this relay exchange function is not used, remote station access is not possible. 	QE71 installed station QnACPU	Chapter 14

15.2 Remote Station PLC Accessible Range and Stations

The accessible range and the stations when performing the remote station access via QE71 using the MELSECNET/10 relay exchange function is described.

15.2.1 Accessible Range and Stations

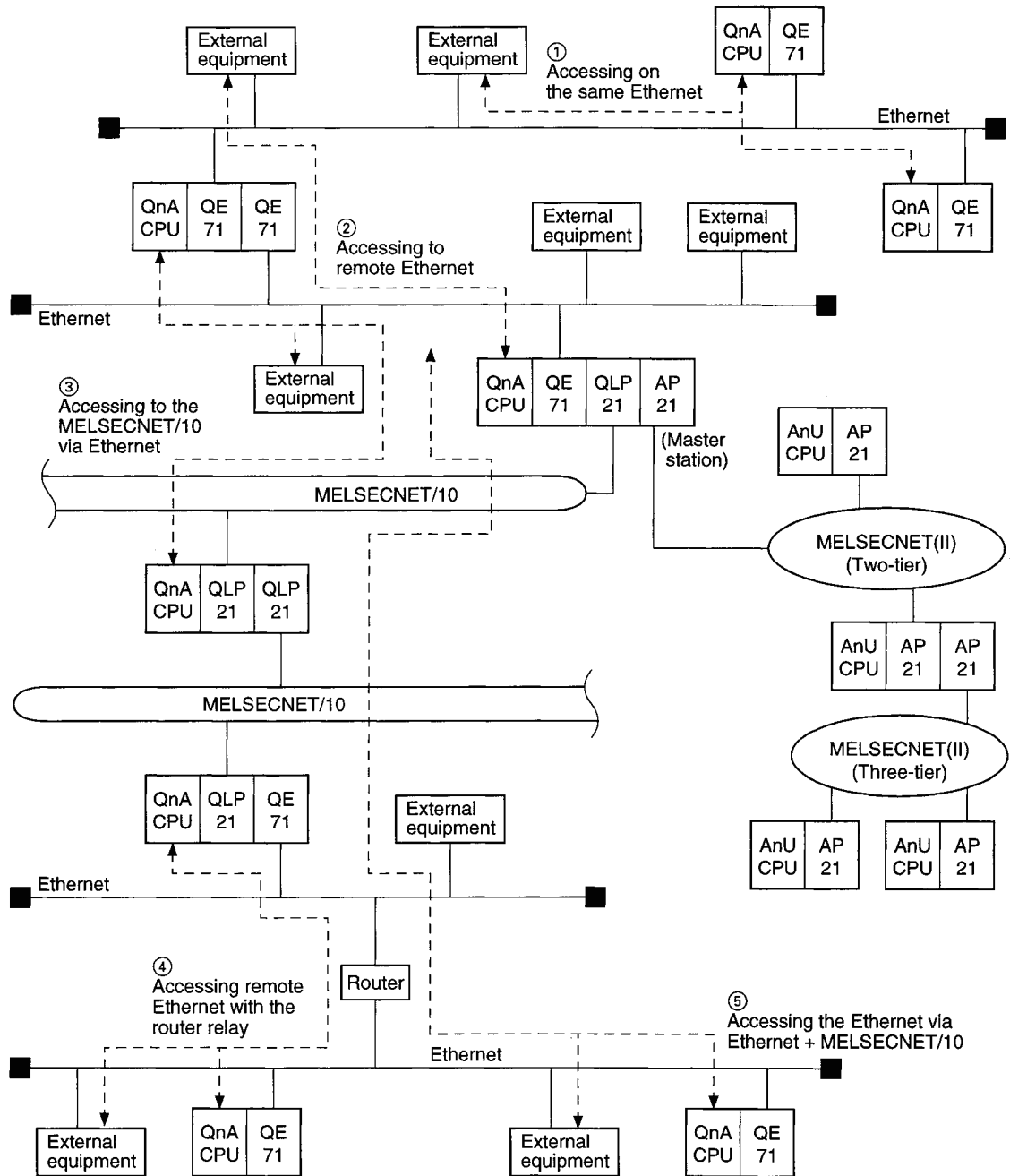

1 Accessible range

- ① Remote stations ① to ⑤ in the diagram on the previous page can be accessed. A maximum of 7 Ethernet and MELSECNET/10 can be used within the MELSECNET/10 specification range.
- ② The network that can be used is only MELSECNET/10 and Ethernet. Remote station access can be performed if the relay stations (exchange relay stations) are all with the following module configurations:

Network used	Module configuration of the relay station (exchange relay station)
MELSECNET/10	<ul style="list-style-type: none"> • QnACPU + MELSECNET/10 network module • AnUCPU + MELSECNET/10 network module
Ethernet	<ul style="list-style-type: none"> • QnACPU + QE71

Remarks

Item 15.3.1 shows an example of the accessible range when performing remote station access from a remote node or QnACPU.

2 Accessible stations (exchange request destination station)

The QnACPU and the A series PLC CPU indicated in the table in Item 9.2.1 can be accessed.

- ① When performing read/write of data in the PLC CPU from a remote node using the QE71 command
The access points and available functions that can be used are as shown in the table in Item 9.2.1.
 - ② When accessing a remote station PLC CPU using the data link command from the QE71 installed station QnACPU
The available functions are as shown in the table in Item 14.4.
The maximum access points are 480/230 words for the QnACPU and 32 words for the A series PLC CPU.
- * When accessing a remote station PLC CPU via MELSECNET/10 only, perform the remote station access according to the QnA compatible MELSECNET/10 Reference Manual. This manual skips the description.

15.2.2 Exchange Request Origin Station/Exchange Relay Station/Exchange Request Destination Station

The terminology and corresponding station relationships are described for the exchange request origin station, exchange relay station, and exchange request destination station, when accessing the remote station via QE71 using the MELSECNET/10 relay exchange function.

Name	Overview	Corresponding station when a remote node performs read/write of data in the PLC CPU	Corresponding station when the QnACPU is accessing a remote station PLC CPU using the data link command
Exchange request origin station	Access request origin station of the remote station access	Because the request from the remote node which is the command transmission origin will be sent to another Ethernet or MELSECNET/10, this is the first QE71 or network module to send the request contents.	QE71 or network module of the QnACPU station which is going to execute the data link command
Exchange relay station (*1)	Relay station of the remote station access Station that sends the received message from a remote node or remote QnACPU to the Ethernet or MELSECNET/10.	<ul style="list-style-type: none"> • Exchange relay receiving station The QE71 or network module of the exchange relay station which receives the exchange request and sends the response. • Exchange relay sending station The QE71 or network module of the exchange relay station which sends the exchange request and receives the response. 	
Exchange request destination station	Access destination station of the remote station access	This is the target station of the remote station access specified by the exchange request origin station. The QE71/network module which is the origin of response message that indicates the result of the requested process.	

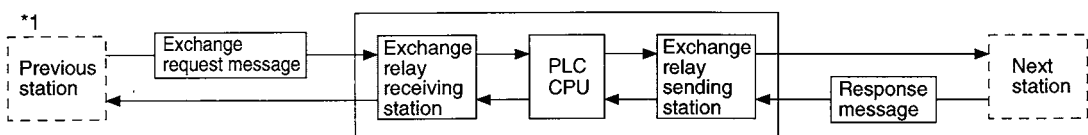

(Example) The exchange request origin station, exchange relay station, and exchange request destination station when performing a remote station access from the remote node or QnACPU in the following system is shown:

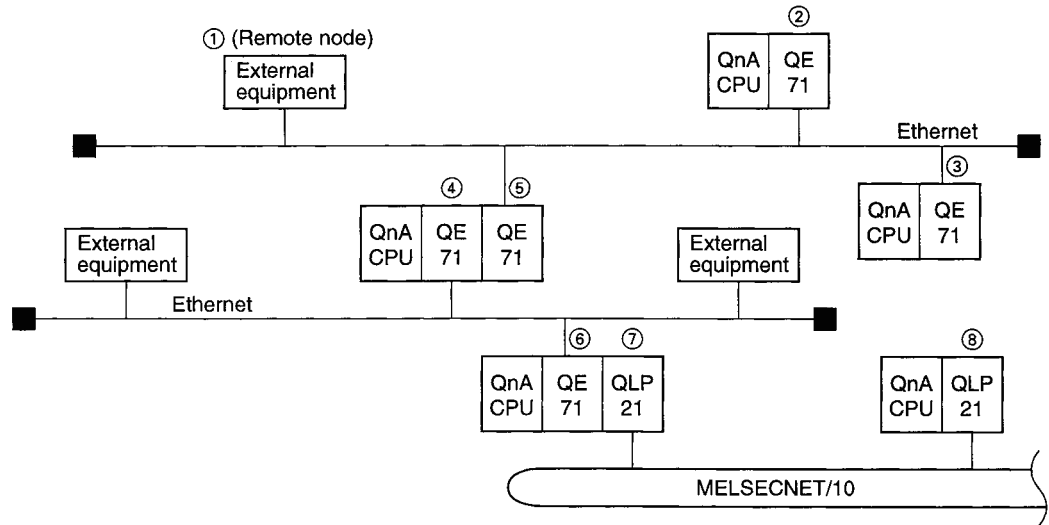

Destination QnACPU	The correspondence between QE71 and network module when performing remote station access to each QnACPU from a remote node ①						
	②	③	④	⑤	⑥	⑦	⑧
Station ②	Request destination station	—	—	—	—	—	—
Station ③	—	Request destination station	—	—	—	—	—
Station ④	—	—	—	—	—	—	—
Station ⑤	—	—	—	Request destination station	—	—	—
Station ⑥	—	—	Relay sending station	Request origin station	Request destination station	—	—
Station ⑦	—	—	—	—	—	—	—
Station ⑧	—	—	Relay sending station	Request origin station	Relay receiving station	Relay sending station	Request destination station

Destination QnACPU	The correspondence QE71 and network module when performing remote station access to each QnACPU from the QnACPU ②							
	②	③	④	⑤	⑥	⑦	⑧	
Station ③	Request origin station	Request destination station	—	—	—	—	—	
Station ④		—	—	—	—	—	—	
Station ⑤		—	—	—	Request destination station	—	—	—
Station ⑥		—	Relay sending station	Relay receiving station	Request destination station	Request destination station	—	—
Station ⑦		—	—	—	—	—	—	—
Station ⑧		—	Relay sending station	Relay receiving station	Relay receiving station	Relay receiving station	Relay sending station	Request destination station

Destination QnACPU	The correspondence QE71 and network module when performing remote station access to each QnACPU from the QnACPU ⑧						
	②	③	④	⑤	⑥	⑦	⑧
Station ②	Request destination station	—	Relay receiving station	Relay sending station	Relay sending station	Relay receiving station	Request origin station
Station ③	—	Request destination station	Relay receiving station	Relay sending station	Relay sending station	Relay receiving station	
Station ④	—	—	Request destination station	—	Relay sending station	Relay receiving station	
Station ⑤	—	—	—	—	—	—	
Station ⑥	—	—	—	—	—	—	
Station ⑦	—	—	—	—	—	Request destination station	

Request origin station : Exchange request origin station Request destination station : Exchange request destination station
 Relay receiving station : Exchange relay receiving station Relay sending station : Exchange relay sending station

15.3 Setting for Remote Station Access

The parameters and setting details necessary to perform the remote station access via QE71 using the MELSECNET/10 relay exchange functions are described.

Point

In order to handle the Ethernet network system in the same class as the MELSECNET/10 network system, the following data (such as the allocation number set by the user) of the QE71 for MELSECNET/10 is set at the QE71 or QE71 installed station QnACPU.

- Network number, group number, station number
- Routing parameter

Make sure the Ethernet network system network number does not overlap with the number allocated to existing system and remote Ethernet network system.

(The default value for the network No. is 239)

Make sure the station number does not overlap with the number allocated to the existing system and remote QE71.

15.3.1 Setting Parameter Types

The types of parameters necessary to set to perform the remote station access via QE71 using the MELSECNET/10 relay exchange function is described for each of local and access station system configuration.

1 When performing read/write of data in the PLC CPU from remote node

No.	System configuration to access station	Parameters that need to be set (Set with GPP) (*1) (*2)			
		Ethernet parameter	Routing parameter	Station No. <-> IP information parameter (*3)	Router relay parameter (*4)
①	PLC CPU on the same Ethernet	×	×	×	×
②	PLC CPU on remote Ethernet	●	●	●	×
③	PLC CPU on the Ethernet + MELSECNET/10 (including the router relay and MELSECNET/10 relay)	●	●	●	△
④	PLC CPU on remote Ethernet with router relay	×	×	×	△
⑤	PLC CPU on the Ethernet + MELSECNET/10 + Ethernet (including the router relay and MELSECNET/10 relay)	●	●	●	△

2 When performing data exchange with remote station PLC CPU from the QnACPU using the data link commands

No.	System configuration to access station	Parameters that need to be set (Set with GPP) (*1) (*2)			
		Ethernet parameter	Routing parameter	Station No. <-> IP information parameter (*3)	Router relay parameter (*4)
①	PLC CPU on the same Ethernet	●	×	●	×
②	PLC CPU on remote Ethernet		●		×
③	PLC CPU on the Ethernet + MELSECNET/10 (including the router relay and MELSECNET/10 relay)		●		△
④	PLC CPU on remote Ethernet with router relay		×		△
⑤	PLC CPU on the Ethernet + MELSECNET/10 + Ethernet (including the router relay and MELSECNET/10 relay)		●		△

● : Always set
 × : Not necessary
 △ : Set when using the router relay function

*1 The following table shows the correspondence between the setting parameters and the setting screen of GPPW and GPPQ.

Setting parameter	GPPW	GPPQ
Ethernet parameter	Setting the number of MNET(II) MNET/10(H) Ethernet cards	Network setting, common parameters setting
Routing parameters	Setting the MNET(II) MNET/10(H) Ethernet routing information (Routing parameters)	Routing parameters
Station No. <-> IP information parameter	Setting the Ethernet Station No. <-> IP information (Station No. <-> IP information)	NET/10 routing information
Router relay parameter	Setting the Ethernet router relay parameter (Router relay)	Routing information

*2 The Station No. <-> IP information parameter and router relay parameter can be set to the buffer memory from the sequence program as well.

*3 If the routing destination is the QE71, the setting can be performed as described in this chapter.

*4 Set the router relay parameters according to Chapter 12 if performing the remote station access by using the router relay function.

This chapter skips the router relay parameter description.

Point

- (1) When performing the remote station access via Ethernet by connecting a GPPW to the QnACPU, the parameters necessary for the system configuration to the access station indicated in 2 above must be set before starting up the corresponding PLC CPU.
- (2) Refer to Item 4.8 for the parameter that can be set with GPPW.

Remarks

In the following system configuration example, the accessible stations and the stations that require parameter settings are indicated for performing remote station access from the remote node or QnACPU.

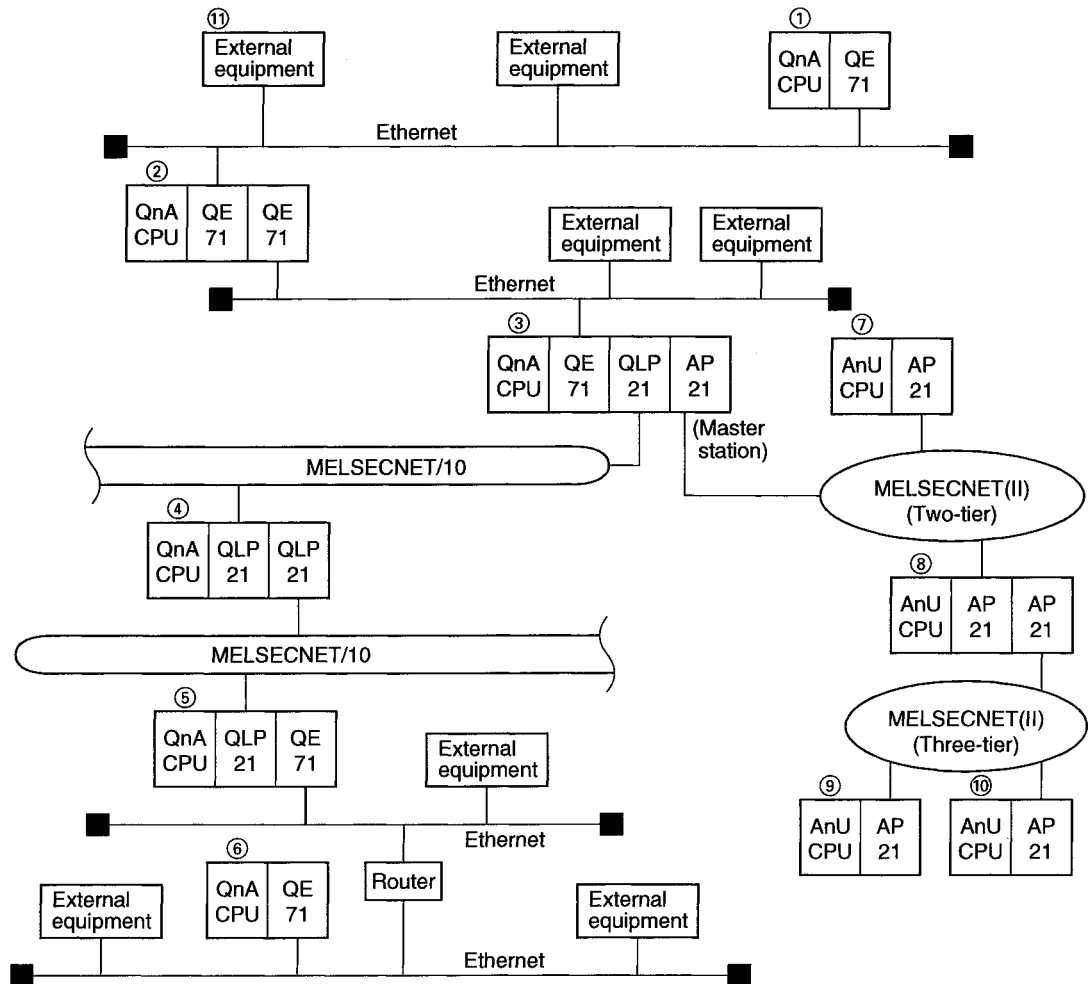

Accessible/not accessible combination	Access destination										
	①	②	③	④	⑤	⑥	⑦	⑧	⑨	⑩	
Access origin	①	○	○	○	○	○	×	×	×	×	
	②	○	○	○	○	○	×	×	×	×	
	③	○	○	○	○	○	△	△	×	×	
	④	○	○	○	○	○	×	×	×	×	
	⑤	○	○	○	○	○	×	×	×	×	
	⑥	○	○	○	○	○	×	×	×	×	
	⑦	×	×	○	×	×	×	×	×	×	
	⑪	○	○	○	○	○	○	×	×	×	

○ : Accessible × : Not accessible
 △ : Accessible (The number of access points, etc., is restricted.)

(1) When performing a remote access from ① to ②

Setting item	Station that does/does not require setting							
	①	②	③	④	⑤	⑥	⑦	⑪
Ethernet parameter	●	●	×	×	×	×	×	×
Routing parameter	×	×	×	×	×	×	×	×
Station No. <-> IP information parameter	●	●	×	×	×	×	×	×
Router relay parameter	×	×	×	×	×	×	×	×

(2) When performing a remote access from ① to ③

Setting item	Station that does/does not require setting							
	①	②	③	④	⑤	⑥	⑦	⑪
Ethernet parameter	●	●	●	×	×	×	×	×
Routing parameter	●	●	×	×	×	×	×	×
Station No. <-> IP information parameter	●	●	●	×	×	×	×	×
Router relay parameter	×	×	×	×	×	×	×	×

(3) When performing a remote access from ① to ⑤

Setting item	Station that does/does not require setting							
	①	②	③	④	⑤	⑥	⑦	⑪
Ethernet parameter	●	●	●	×	×	×	×	×
Routing parameter	●	●	●	●	×	×	×	×
Station No. <-> IP information parameter	●	●	●	×	×	×	×	×
Router relay parameter	×	×	×	×	×	×	×	×

(4) When performing a remote access from ① to ⑥

Setting item	Station that does/does not require setting							
	①	②	③	④	⑤	⑥	⑦	⑪
Ethernet parameter	●	●	●	×	●	●	×	×
Routing parameter	●	●	●	●	●	×	×	×
Station No. <-> IP information parameter	●	●	●	×	●	●	×	×
Router relay parameter	×	×	×	×	●	●	×	×

(5) When performing a remote access from ① to ⑦

Setting item	Station that does/does not require setting							
	①	②	③	④	⑤	⑥	⑦	⑪
Ethernet parameter	●	●	●	×	×	×	×	×
Routing parameter	●	●	●	×	×	×	×	×
Station No. <-> IP information parameter	●	●	●	×	×	×	×	×
Router relay parameter	×	×	×	×	×	×	×	×

● : Always set
 × : Not necessary

(6) When performing a remote access from ⑪ to ①

Setting item	Station that does/does not require setting							
	①	②	③	④	⑤	⑥	⑦	⑪
Ethernet parameter	●	x	x	x	x	x	x	x
Routing parameter	x	x	x	x	x	x	x	x
Station No. <-> IP information parameter	●	x	x	x	x	x	x	x
Router relay parameter	x	x	x	x	x	x	x	x

(7) When performing a remote access from ⑪ to ③

Setting item	Station that does/does not require setting							
	①	②	③	④	⑤	⑥	⑦	⑪
Ethernet parameter	x	●	●	x	x	x	x	x
Routing parameter	x	●	x	x	x	x	x	x
Station No. <-> IP information parameter	x	●	●	x	x	x	x	x
Router relay parameter	x	x	x	x	x	x	x	x

(8) When performing a remote access from ⑪ to ④

Setting item	Station that does/does not require setting							
	①	②	③	④	⑤	⑥	⑦	⑪
Ethernet parameter	x	●	●	x	x	x	x	x
Routing parameter	x	●	●	x	x	x	x	x
Station No. <-> IP information parameter	x	●	●	x	x	x	x	x
Router relay parameter	x	x	x	x	x	x	x	x

(9) When performing a remote access from ⑪ to ⑥

Setting item	Station that does/does not require setting							
	①	②	③	④	⑤	⑥	⑦	⑪
Ethernet parameter	x	●	●	x	●	●	x	x
Routing parameter	x	●	●	●	●	x	x	x
Station No. <-> IP information parameter	x	●	●	x	●	●	x	x
Router relay parameter	x	x	x	x	●	●	x	x

(10) When performing a remote access from ⑪ to ⑦

Setting item	Station that does/does not require setting							
	①	②	③	④	⑤	⑥	⑦	⑪
Ethernet parameter	x	●	●	x	x	x	x	x
Routing parameter	x	●	●	x	x	x	x	x
Station No. <-> IP information parameter	x	●	●	x	x	x	x	x
Router relay parameter	x	x	x	x	x	x	x	x

● : Always set

x : Not necessary

15.3.2 Ethernet Parameters

The setting details for the Ethernet parameter required for performing the remote station access via QE71 using the MELSECNET/10 relay exchange functions are described below.

- 1 The Ethernet parameters are the information regarding the target QE71 installed to the local station.
- 2 The Ethernet parameters are set in the GPP, and registered in the QnACPU at each QE71 installed.
- 3 Setting items and setting details in the "Network parameters setting the number of MNET (II) MNET/10 (H) Ethernet cards" screen of GPPW for the Ethernet parameter setting are as follows (*1):

"Network parameters setting the number of MNET (II) MET/10(H) Ethernet card" screen.

(Network type)

- Specify "Ethernet."

(start I/O No.)

- The start I/O signal (I/O signal No. with the PLC CPU) of the QE71 that is the target of the Ethernet parameter to be set is specified unchanged. (When the start I/O signal is X/Y100, "100" is specified.)

(Network No.)...default value: 239

- The MELSECNET/10 network number (setting range:1 to 239) to allocate to the Ethernet network system where the subject QE71 is connected is specified.

- Do not overlap this value with the existing system or remote Ethernet network system network number

(Group No.)

- Specify the MELSECNET/10 group number (setting range: 0 to 9) allocated to the subject QE71.

0: No group specification

1 to 9: Group No.

- By setting the group number, data exchange can be performed to multiple QnACPU stations in the same group.

(Station No.)

- Specify the MELSECNET/10 station number (setting range: 1 to 64) to be allocated to the target QE71.

- Do not overlap this value with the number allocated to the existing system or other QE71.

(IP Address)

- Specify the IP address necessary for the target QE71 initial processing in decimal/hexa-

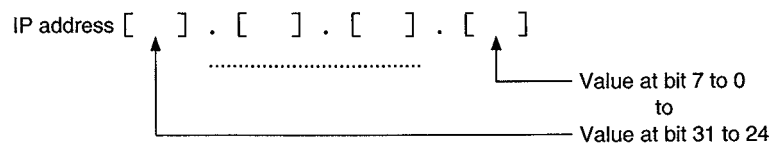

decimal for each 8 bits.

- When the IP address is specified, the IP address setting to the buffer memory from the sequence program during initial processing is not necessary.

(Station No. <-> IP information)

- Set the parameters for using the MELSECNET/10 relay exchange function, etc. (see Item 15.3.4).

(FTP Parameters)

- Set the parameters for using the file transfer function (see Item 13.3).

(Router relay parameter)

- Set the parameters for specifying the subnet mask and using the router relay function (see Items 11.2 and 12.4).

(Routing parameters)

- Set the parameters for accessing remote stations via the QE71, using the MELSECNET/10 relay exchange function (see Item 15.3.3).

*1 When GPPQ is used, set all of the above parameters on the Number of modules setting screen, Network setting screen or other relevant screens.

Remarks

- (1) Specify the router relay parameter and FTP parameter by referring to the explanations in Chapters 12 and 13 when the corresponding functions described in Chapter 12 and 13 are used.
- (2) The network No., group No., station No. and IP address do not be set by the GPP but can be set with the EPRSET instruction from the PLC CPU.
- (3) The display contents of "Network parameters Setting the number of MNET (II) MNET/10(H) Ethernet card" screen for GPPW is as follow.

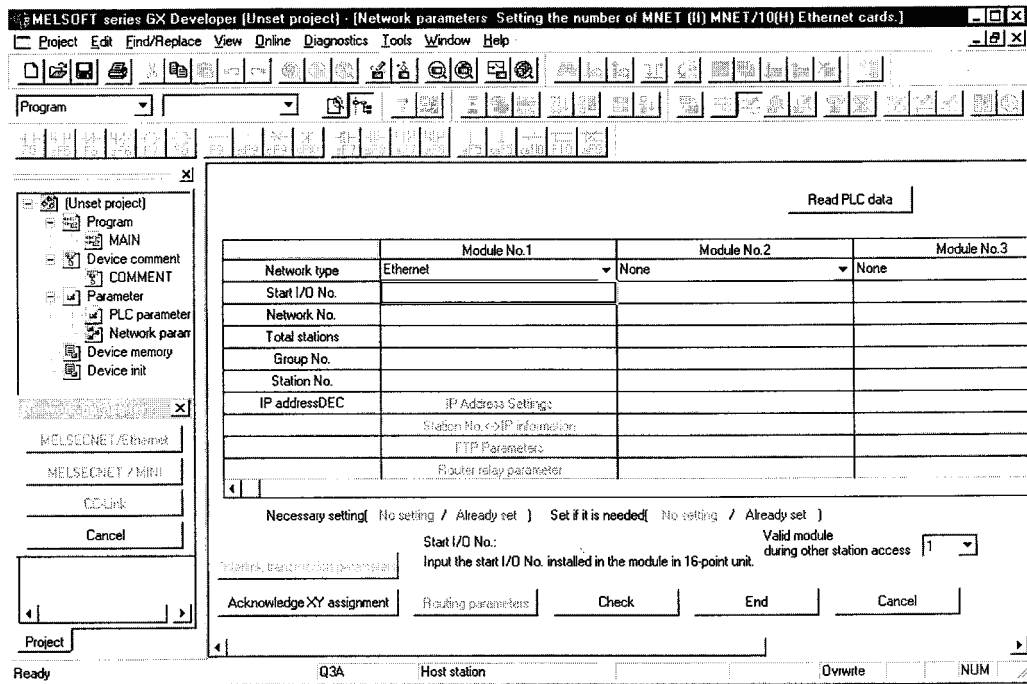

15.3.3 Routing Parameters

The routing parameter setting required for performing the remote station access via QE71 using the MELSECNET/10 relay exchange function is indicated below.

1 The routing parameters are the Ethernet and MELSECNET/10 information referred for the MELSECNET OS to perform the remote station access using the transient transmission function.

2 The routing parameters are set in the GPP routing parameter screen in the same way as the network module, for the MELSECNET/10 network number and station number to be allocated to the network module or QE71. The data is registered in the PLC CPU station which requires the setting.

* The registration can be performed by issuing a RTWRITE command from the PLC CPU.

3 The setting items and details of the GPP routing parameter screen to set the routing parameters are as shown below:

#	TX Dest Network #	Relay Network #	Relay Station #	Via Station #
1	[]	[]	[] sta	[] sta
2	[]	[]	[] sta	[] sta

① TX Dest Network #

When the exchange request message is being transmitted, specify the exchange request destination station. When the response message is being transmitted, specify the Ethernet or MELSECNET/10 network number where the exchange request origin station is connected.

② Relay Network #

Specify the next exchange relay receiving station is specified when the exchange request message is being transmitted. Specify the Ethernet or MELSECNET/10 network number where the exchange relay sending station is connected when the response message is being transmitted.

③ Relay Station #

Specify the station number of the relay target QE71/network module in the network in specified in the relay destination network number

④ Via Station # (first station is the target if not specified)

When more than two QE71 or network module are installed with the same network number at the station which requires routing parameter setting, specify the station number of the QE71 or network module to pass through.

When the QE71 or network module does not exist with the same network number, the pass-through station number specification is not necessary.

4 The stations that require the routing parameter setting and registration are as follows:

① PLC CPU at exchange request origin station

② PLC CPU at exchange relay station of the exchange request message (relay receiving station + relay sending station)

PLC CPU at the exchange relay station of the response message (relay receiving station + relay sending station)

(PLC CPU station which relays between Ethernet and Ethernet, Ethernet and MELSECNET/10, or MELSECNET/10 and MELSECNET/10.)

Remarks

- (1) The routing parameters setting is not necessary for the remote station access on the same Ethernet network as the remote node/local station QnACPU.
- (2) The routing parameters are set in the following manner:

To go to a station on the network No. ○, relay through the station No. □ on the network No. △ which is the first exchange relay from the local station.

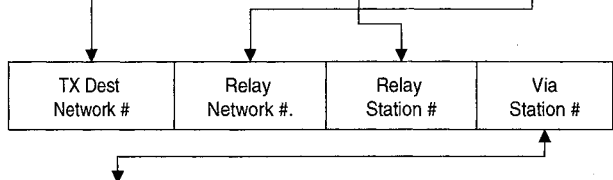

Send data from the local station No. × module to the first exchange relay station.

- (3) As an example, to perform remote station access from station 1N3 to 3Ns4 in the diagram below, the following values are set to the specified stations which require the routing parameter setting.

- Exchange request origin station : Station 1N3
- Exchange relay station : Station 1N4/2Mp1, and Station 2Ns4/3Ns5

* The code used for each station in the diagram indicates the network number of the MELSECNET/10 or Ethernet, station type, and station number. Refer to Item 9.1.2 for the description of the codes.

* The pass-through station number specification is not necessary in the following system configuration because there is no two or more of the QE71 or network module with the same network number for the stations that require the routing parameter setup.

However, the specification values are indicated in the diagram.

* A maximum of 64 "transfer destination network number" can be set in the QnACPU.

64 types of network number can be specified when the local station is the request origin or performing a remote station access via itself.

However, the same transfer destination network number cannot be set multiple times.

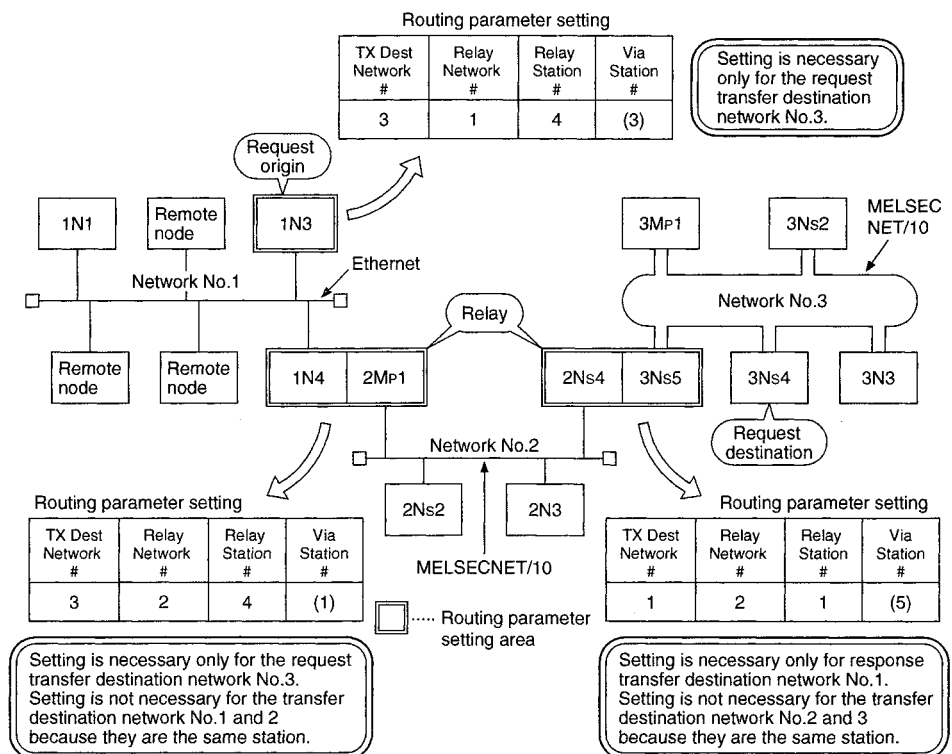

15.3.4 Station No. <-> IP Information Parameters

The setting details of the Station No. <-> IP information parameters which are necessary to perform the remote station access via QE71 using the MELSECNET/10 relay exchange functions are described below.

1 The exchange between the QE71 and QnACPU are performed based on the network numbers and station numbers. The exchange between the QE71 and QE71 are performed based on the IP addresses and UDP port numbers.

Therefore, the QE71 must perform the following data conversions:

MELSECNET/10 network number and station number ` Ethernet IP address and UDP port number

2 It is necessary to set the Station No. <-> IP information parameters for the QnA CPUs of all QE71 installed stations that are used as paths for remote station access.

3 The Station No. <-> IP information parameters are set by selecting from the GPP and registered to the QnACPU with the corresponding QE71 installed.

The Station No. <-> IP information parameters registered in the QnACPU are stored (transferred) to the next QE71 buffer memory and used when the QnACPU started by turning on the power or resetting the QnACPU.

GPPW Setting the Ethernet Station No. <-> IP information	QE71 buffer memory storage destination		Remark
	Address (Decimal)	Name	
Station No. <-> IP information system	4	Special function setting area (bits 6 to 7)	Automatically stored during QE71 initial processing
Net mask pattern	937 to 938	Net mask pattern area for MELSECNET/10 routing	
Conversion Setting	553 to 936	Conversion table (conversion information number 1 to 64) area	
	552	Conversion table data count area	No setting with GPPW

Remarks

The Station No. <-> IP information parameters can be set directly from the QnACPU to the above buffer memory during the QE71 initial processing.

When performing the setting from the QnACPU, set the number of conversion information (1 to 64) to be set in the conversion table in the conversion table data count area.

4 The specification contents for Select Station No. <-> IP information system (Convert Form) (default value: Automatic Answers)

- ① There are four types of Station No. <-> IP information system (Convert Form). Specify one from Item 15.3.5.
- ② The Mask Pattern and Convert Settings must be done depending on the Convert Form specified. Always set according to the following table. If a required parameter is not set, a normal exchange cannot be performed.

	Station No. <-> IP information parameter setting requirement		
	Convert Form	Mask Pattern	Convert Setting
①	Automatic Answers	×	×
②	Compute IP Address	○	×
③	Table Convert	×	○
④	IP Address & Table	○	○

○: Specification necessary ×:Specification not necessary

5 The specification contents of Mask Pattern (netmask pattern for MELSECNET/10 routing) (default value: none)

When calculating the destination station IP Address using the Compute IP Address, the mask value used in the logical multiplication with the local IP address is specified as shown below:

- ① When setting the subnet mask shown in Chapter 11, specify a Mask Pattern which makes for the bit ranges for the class/subnet address of the IP address all "1."

(Example)

When bit 12 to 29 is the subnet address in class B, FF.FF.F0.00H are specified.

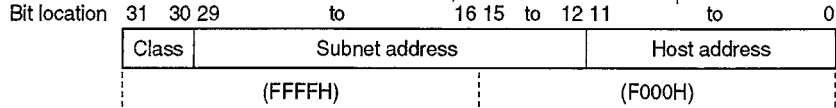

The Mask Pattern specification method is specified using decimal/hexadecimal numbers which divide the 32 bit mask value into 8-bit units.

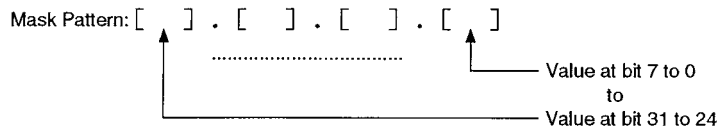

- ② When the subnet mask is not set, the Mask Pattern specification is not necessary.

When the Mask Pattern is not specified, the following mask value is used as the Mask Pattern according to the local IP Address class.

Class	Mask value used
Class A	FF. 00. 00. 00H
Class B	FF. FF. 00. 00H
Class C	FF. FF. FF. 00H

- ③ The Mask Pattern specified is stored in the next position in the QE71 buffer memory.

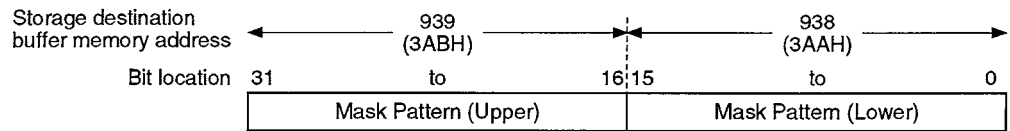

6 The specification contents of Convert Setting (conversion information) Network # and station # (default value: none)

- ① These are set to obtain the IP address from the network number and the station number using the table conversion method.
- ② Specify the network number and station number of the next station's QE71 to which an exchange request message/response message for accessing a remote station will be passed in exchange via Ethernet.

(Numbers assigned with Ethernet parameters shown in Item 15.3.2)

Specify the network number from 1 to 239 (1H to EFH) and the station number from 1 to 64 (1H to 40H).

* A specification example is shown in item (3) of Item 15.3.5.

- ③ The specified network number and station number are stored in the following positions in the QE71 buffer memory.

(Example) For the conversion information (No. 1)

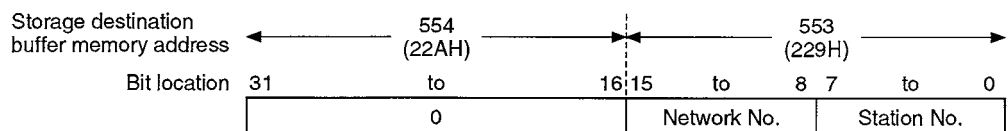

7 The specification contents of Convert Setting (conversion information) IP Address (default value: none)

① When the above network number and station number shown in (6) are specified, specify the IP Address of the next station's QE71 to hand the exchange request response message for the remote station access.

The specification example is indicated in Item 15.3.5 **3**.

② The IP Address is specified by splitting the 32-bit IP address value into 8 bits each in decimals/hexadecimal.

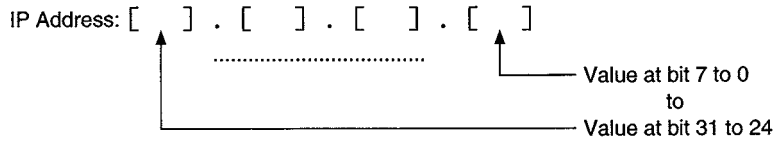

③ The specified IP Address is stored in the next position in the QE71 buffer memory.

(Example) For the conversion information (No. 1)



Remarks

The buffer memory used when setting the Station No. <-> IP information parameters directly from the QnACPU during the QE71 initial processing is shown below.

Set the values according to the Station No. <-> IP information parameter descriptions in this section.

Set the values in the same manner as the values specified in the GPP to the storage area in the buffer memory.

Buffer Memory

(Address)	Station No. <-> IP information parameter setting area (387 words)		Default value	Setting requirement for each convert format			
				Auto-matic	IP	Table	Combination
228H (552)	Number of conversion table data (1 word)		0H(0)				
229 to 22AH (553 to 554)	Network number and station number of the exchange request destination station /exchange request origin station	Conversion information (No. 1) (6 words)	0H(0)				
22B to 22CH (555 to 556)	Local network QE71's IP address		0H(0)				
22D to 22EH (557 to 558)	System area		—				
22F to 230H (559 to 560)	Network number and station number of the exchange request destination station /exchange request origin station	Conversion table (No. 2) (6 words)	0H(0)	x	x	○	○
231 to 232H (561 to 562)	Local network QE71's IP address		0H(0)				
233 to 234H (563 to 564)	System area		—				
to	to		to				
3A3 to 3A4H (931 to 932)	Network number and station number of the exchange request destination station /exchange request origin station	Conversion information (No. 64) (6 words)	0H(0)				
3A5 to 3A6H (933 to 934)	Local network QE71's IP address		0H(0)				
3A7 to 3A8H (935 to 936)	System area		—				
3A9 to 3AAH (937 to 938)	Net mask pattern for MELSECNET/10 routing (2 words)		0H(0)	x	○	x	○

○: Setting necessary x: Setting not necessary

* Meaning of the abbreviations in the setting requirement for each Convert Form column

Automatic : Automatic Answers

IP : Compute IP Address

Table : Table Convert

Combination : IP Address & Table

1) Number of conversion table data (default value: 0H).....Address 228H(552)

- ① Sets the number of pairs of conversion information to be set in the conversion table.
- ② Sets the setting value within the range 1 to 64. If a value of 65 or more is specified, it is regarded as if value 64 is specified.

2) Conversion information: Network number and station number of the exchange request destination station/exchange request origin station (default value: 0H).....Address 229 to 22AH (553 to 554)...

Follow the Convert Setting descriptions shown in (6), and set the network number (1 to 239) and station number (1 to 64) in hexadecimal for the QE71 which will be the exchange request destination station/exchange request origin station.

(Example) For the conversion information (No. 1)

The network number and station number are set in the following bit range. "0" is set in the area where the buffer memory address is 22AH.

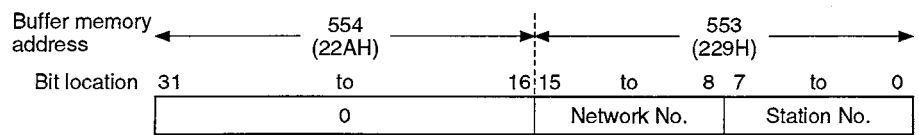

3) Conversion information: Local network QE71's IP Address (default value: 0H)

..... Address 22B to 22CH (555 to 556)...

Follow the Convert Setting descriptions shown in (7), and set the IP address of the next station's QE71 to hand the exchange request response message for the remote station access.

(Example) For the conversion information (No. 1)

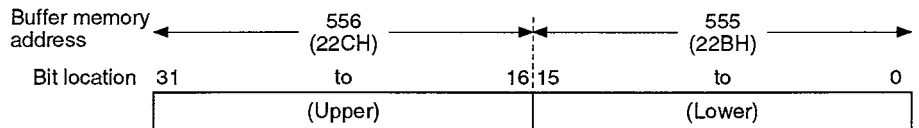

4) Net mask pattern MELSECNET/10 Routing (default value: 0H)

..... Address 3A9 to 3AAH (937 to 938)

- ① Follow the Mask Pattern descriptions in (5), and set the mask value used in the logical product with the local station IP address when calculating the partner station's IP Address in the Compute IP Address.

(Example) FFFF000H is set when the bit 12 to 29 is used as the subnet address in class B.

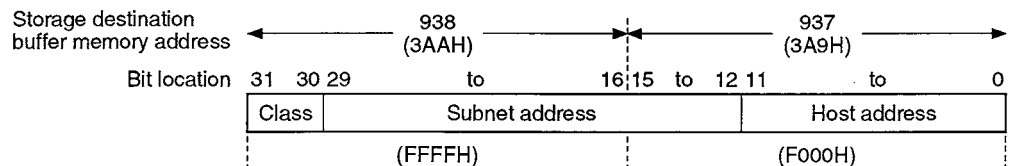

- ② When the following mask values are used, the Mask Pattern setting is not necessary.

Class	Mask value used
Class A	FF. 00. 00. 00H
Class B	FF. FF. 00. 00H
Class C	FF. FF. FF. 00H

* When the Mask Pattern is not set, the mask value listed in the table is used depending on the local IP Address class.

15.3.5 Convert Format between the Network Number/Station Number and IP Address/Port Number

The process overview of the conversion method of the Station No. <-> IP Information parameters for performing the remote station access via QE71 using the MELSECNET/10 relay exchange function is described.

Select one of the conversion methods, and set it to Station No. <-> IP Information parameter.

The relationship between the Convert Format and definition of the QE71 installed station is as follows.

Conversion method	QE71 installed station definition			
	Exchange request origin station	Exchange relay station		Exchange request destination station
		Relay receiving station	Relay sending station	
Automatic Answers	× (*1)	○	× (*1)	○
Compute IP Address	○	○	○	○
Table Convert	○	○	○	○
IP Address & Table	○	○	○	○

○: Can be specified ×: Cannot be specified

*1 For the remote node that completed the exchange, the station can be a exchange request origin station or a relay sending station.

1 Automatic Answers (Automatic response method)(QE 71 default value)

- ① The Automatic Answers differs from the other Convert Format in that specifications can only be made when the QE71 installed station is the exchange request destination station or exchange relay receiving station.

The partner station IP Address or port number setting are not necessary with this conversion method, making the MELSECNET/10 relay exchange performed easily.

(When the local QnACPU performs the remote station access)

- ② When the QE71 receives a remote station access exchange request message (command

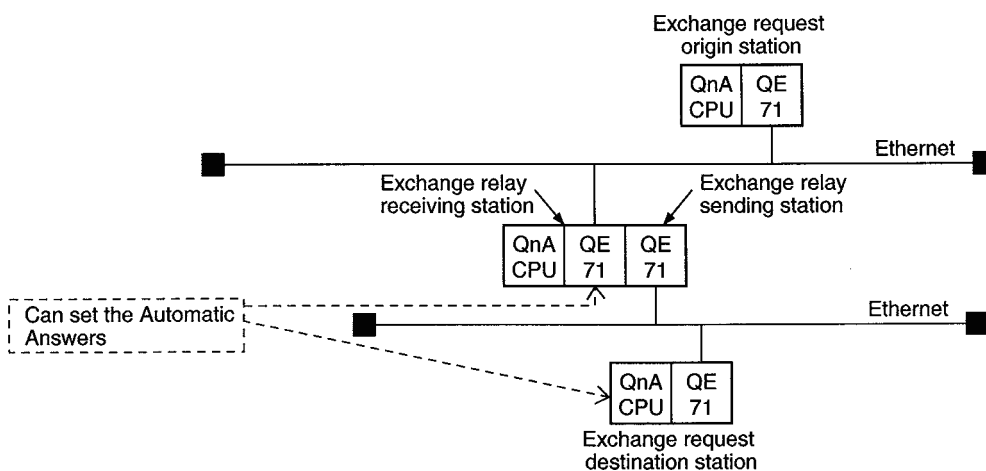

frame) from the MELSECNET/10 relay exchange function, the transmission origin network number, station number, IP address, and UDP port number in the request message, are stored internally.

The response message for the exchange request message is returned to the destination IP address and UDP port number calculated from the stored network number and station number.

Therefore, by receiving the remote station access communication request message first, the exchange partner stations can be maintained.

- ③ The number of stations that can be set for station information is up to 64 stations.

When more than 64 stations for remote station access exchange request message is received, the QE71 starts deleting from the oldest data to store the station information in the newly received message exchange request message.

However, it is ignored if the station information is the same as the station information already stored. (Will not store duplicate records.)

2 Compute IP Address (IP address calculation method)

- ① The partner station IP Address is obtained from the request station's network number and station number, and the system constant UDP port number is used for the destination UDP port number.
- ② When the QE71 receives the remote station access exchange request message (command frame) from the MELSECNET/10 relay exchange function, the calculations of the IP address (as shown below) are performed based on the network number and station number of the destination of the exchange request message, and the exchange request message is sent to the next station. (The destination network number and station number are stored internally.)

The response message for the exchange request data is returned according to the return destination IP Address and above stored data.

- ③ The specification can be performed when accessing a remote station on the same network number, or when relaying to the other network (the MELSECNET/10, Ethernet).
The setting target QE71 can be either exchange request origin station, exchange relay station, or exchange request destination station.
- ④ The calculation method for the QE71 to obtain the IP Address from the target station network number and station number are as follows:

Refer to Item 15.3.4 regarding the MELSECNET/10 Routing Net Mask Pattern.

$$\text{Destination station IP Address} = \left(\begin{array}{c} \text{Local station IP Address} \\ \text{Logical product} \\ \text{MELSECNET/10 Routing Net Mask Pattern} \end{array} \right) \text{ Logical sum } \begin{array}{c} \text{Destination network number,} \\ \text{station number} \end{array}$$

Remarks

- Class A IP Address format

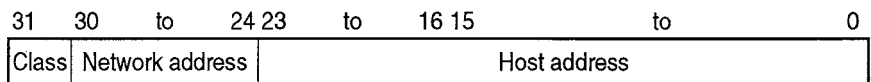

- Class B IP Address format

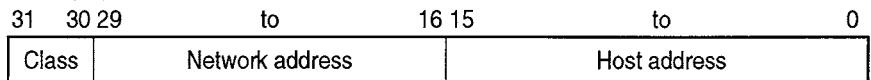

- Class C IP Address format

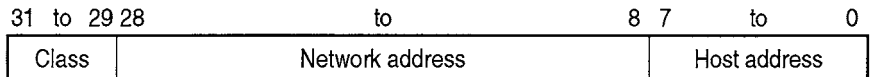

- ⑤ The logical sum handling is different depending on the local IP Address class, and the calculation is performed as follows:

(For class A)

- When the local station IP Address is 79238102_H
- When the MELSECNET/10 Routing Net Mask Pattern is FF000000_H
- When the destination network number is 03_H, and the station number is 05_H

Local station IP Address	7 9 . 2 3 . 8 1 . 0 2
Net Mask Pattern	F F . 0 0 . 0 0 . 0 0
Logical product value	7 9 . 0 0 . 0 0 . 0 0
Network No. and station No.	0 3 . 0 5
Destination station IP Address	7 9 . 0 0 . 0 3 . 0 5

(For class B)

- When the local station IP Address is 8438FA0A_H
- When the MELSECNET/10 Routing Net Mask Pattern is FFFF0000_H
- When the destination network number is 03_H and station number is 05_H

Local station IP Address	8 4 . 3 8 . F A . 0 A
Net Mask Pattern	F F . F F . 0 0 . 0 0
Logical product value	8 4 . 3 8 . 0 0 . 0 0
Network No. and station No.	0 3 . 0 5
Destination station IP Address	8 4 . 3 8 . 0 3 . 0 5

(For class C)

- When the local station IP Address is CA65300A_H
- When the MELSECNET/10 Routing Net Mask Pattern is FFFFFFF0_H
- When the destination station number is 02_H (The network number is not used.)

Local station IP Address	C A . 6 5 . 3 0 . 0 A
Net Mask Pattern	F F . F F . F F . 0 0
Logical product value	C A . 6 5 . 3 0 . 0 0
Network No. and station No.	0 2
Destination station IP Address	C A . 6 5 . 3 0 . 0 2

3**Table conversion method**

- ① This method uses the network number, station number and IP address set in the conversion table of the Station No. <-> IP information parameters, and uses the UDP port number preassigned in the QE71 system for the partner station's UDP port number.
- ② When the QE71 receives an exchange request message (command frame) for accessing a remote station using the MELSECNET/10 relay exchange function, it searches for the same network number and station number from the conversion table, and sends an exchange request message to the partner station having the corresponding IP address.
- ③ The specification can be performed when accessing a remote station on the same network number, or when relaying to the other network (the MELSECNET/10, Ethernet.)
The setting target QE71 can be either exchange request origin station, exchange relay station, or exchange request destination station.
- ④ In the conversion table of each QE71 using the table conversion method, set all of the network number and station number of the exchange request destination station or the exchange request origin station, and the corresponding IP address.
(Numbers assigned with Ethernet parameters shown in Item 15.3.2)
* If all of the above data are not set, data exchange may not be performed normally.
A specification example is shown on the next page.
- ⑤ If the same network numbers and station numbers are specified in duplicates, data set with the younger registration number will be used.

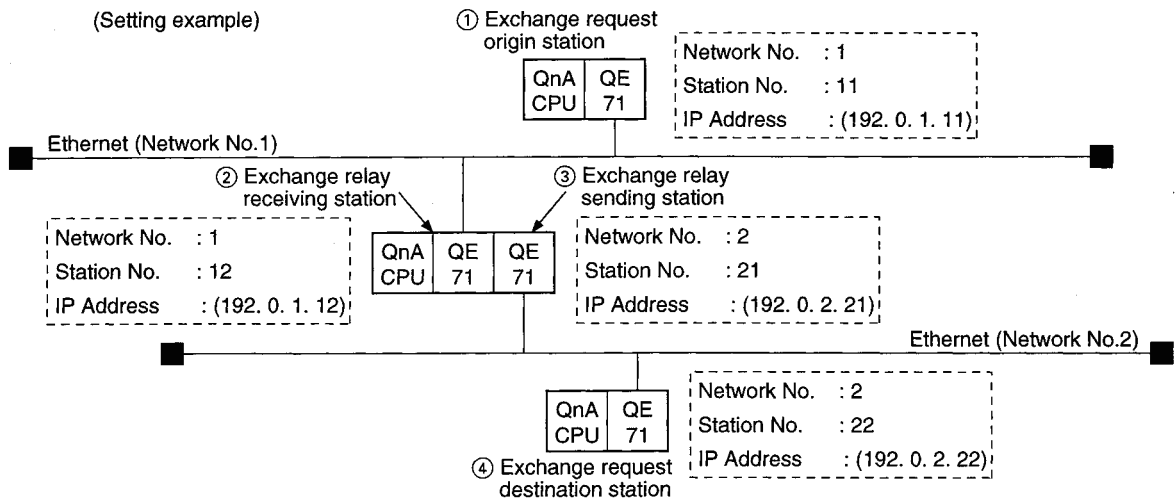

		QE71 station setting details when accessing from QnACPU ① to QnACPU ②			
		①Exchange request origin station (T)	②	③	④
Setting value (Decimal)	Network No.	1, 12	Setting not necessary	Setting not necessary	Setting not necessary
	Station No.				
	IP Address	192. 0. 1. 12			

		QE71 station setting details when accessing from QnACPU ① to QnACPU ④			
		①Exchange request origin station (T)	②Exchange relay receiving station (R)	③Exchange relay sending station (T)	④Exchange request destination station (R)
Setting value (Decimal)	Network No.	1, 12	1, 11	2, 22	2, 21
	Station No.				
	IP Address	192. 0. 1. 12	192. 0. 1. 11	192. 0. 2. 22	192. 0. 2. 21

		QE71 station setting details when accessing from QnACPU ② to QnACPU ①			
		①	②Exchange request origin station (T)	③	④
Setting value (Decimal)	Network No.	Setting not necessary	1, 11	Setting not necessary	Setting not necessary
	Station No.				
	IP Address				

		QE71 station setting details when accessing from QnACPU ③ to QnACPU ④			
		①	②	③Exchange request origin station (T)	④
Setting value (Decimal)	Network No.	Setting not necessary	Setting not necessary	2, 22	Setting not necessary
	Station No.				
	IP Address				

		QE71 station setting details when accessing from QnACPU ④ to QnACPU ①			
		①Exchange request origin station (R)	②Exchange relay sending station (T)	③Exchange relay receiving station (R)	④Exchange request origin station (T)
Setting value (Decimal)	Network No.	1, 12	1, 11	2, 22	2, 21
	Station No.				
	IP Address	192. 0. 1. 12	192. 0. 1. 11	192. 0. 2. 22	192. 0. 2. 21

		QE71 station setting details when accessing from QnACPU ④ to QnACPU ③			
		①	②	③	④Exchange request origin station (T)
Setting value (Decimal)	Network No.	Setting not necessary	Setting not necessary	Setting not necessary	2, 21
	Station No.				
	IP Address				

* The (T) and (R) in the QE71 station setting details column indicate whether the value is for the exchange request message transmission or response message transmission.
 (T): For exchange request message transmission (R): For response message transmission

4

IP Address & Table (Combination method)

- ① This is a method which combines the Compute IP Address and Table Convert.
- ② When the QE71 receives the remote station access exchange request message (command frame), the IP Address of the QE71 on the local network to hand the data next, is obtained in the Table Convert first, and then sends the exchange request message.

If the QE71 IP Address cannot be obtained by the Table Convert, it is obtained using the Compute IP Address, and the message is sent.

The response message for the exchange request message is returned according to the return IP Address, above conversion table data or stored data.

- ③ It is possible to specify this method when accessing remote stations within a network having the same network No. or relaying to another network (MELSECNET/10, Ethernet).
The target QE71 can be either the exchange request origin station, exchange relay station, or exchange request destination station.

15.4 Remote Access Procedure

The procedure and necessary processing to perform the remote station access via QE71 using the MELSECNET/10 relay exchange function are described.

1 Registering the parameters

Set the parameters indicated in Item 15.3 with the GPP, and register in the corresponding PLC CPU.

* The Station No. <-> IP information parameters and router relay parameters do not have to be stored with the GPP, but instead, can be set to the QE71 buffer memory from the QnACPU during the QE71 initial processing.

Also, the routing parameters do not have to be stored with the GPP, and can be read/written using the data link command RTREAD and RTWRITE. (Refer to the QnACPU Programming Manual (Common command Edition).)

2 Restarting the QnACPU

The Station No. <-> IP information parameters registered in the QnACPU are automatically stored (transferred) to the QE71 buffer memory and referred when the QnACPU starts up again after the power reset or QnACPU reset.

3 QE71 initial processing

- ① The initial processing for each QE71 installed station is performed as described in Item 5.2.
- ② When initial processing at each QE71 which is used for the remote station access is successfully completed, the remote station access line (*1) for the MELSECNET/10 relay exchange function is automatically opened. (Passive open completion state)

This enables the remote station access to the corresponding station from a remote node/local station QnACPU.

*1 This is also called the automatic open UDP connection.

4 Remote station access

- ① The remote station access is performed from the remote node/local station QnACPU with the MELSECNET/10 relay exchange function.
- ② The remote station access with the MELSECNET/10 relay exchange function is performed in the UDP/IP protocol, and the data exchange is constantly performed in binary code.
- ③ The QE71 system port number (UDP/IP port) is used for the data exchange.
- ④ The remote station access can continue as long as the initial normal end signal (X19) is on.

* When the initial normal end signal (X19) turns off, the line is forcefully closed even if the QE71 is performing a remote station access.

5 QE71 end processing

- ① When ending a remote station access with the MELSECNET/10 relay exchange function, the end processing is performed as stated in the description in Item 5.5.
- ② When the end processing has been performed, the remote station access line is automatically closed.
- ③ When the end processing is performed during a remote station access, the command being executed results in error. The result of the processing by the command is not guaranteed.

15.5 Precautions When Performing the Remote Station Access

The precautions when performing a remote station access via QE71 with the MELSECNET/10 relay exchange function is described.

1 QnACPU and GPP software versions

The remote station access can be performed if the local station QnACPU is the product shown in Item 2.5.3.

2 In the user's discretion, do not overlap the network number of the QE71's Ethernet network system with that of existing MELSECNET/10 network system or remote Ethernet network systems.

Do not overlap the Ethernet network system station number with the above systems or numbers allocated to other QE71s.

3 Status check of local station, relay station, and access destination station

When routing through the MELSECNET/10, check the local, relay station, and access destination station status with the following device, and perform the remote station access only if the status is normal.

- Link special relay : SB20, SB47, SB70, SB30 to 3E, etc.
- Link special register : SW70 to 73, SW74 to 77, etc.

4 The remote station access from the MELSECNET/10 relay exchange function is performed with the UDP/IP protocol, and the exchange is always performed with data in binary code.

Point

For the interlock signals, link data send/receive processing, and processing time when performing data exchange with the remote station QnACPU through the MELSECNET/10, refer to the MELSECNET/10 Reference Manual.

16. WHEN EXCHANGING WHILE PLC CPU IS STOP

When the QnACPU with the QE71 installed is at the stop state or when the QE71's open request signal (Y8 to YF) or initial request signal (Y19) is off, the data exchange can be continued from a remote node to QE71.

This chapter describes the setting to use the data exchange functions when the PLC CPU is in the stop state.

Point

Perform the data exchange while the PLC CPU is at stop state according to the system specifications.

16.1 Data Exchange While PLC CPU is Stop

Data exchange while the PLC CPU is at the stop state is described.

- 1 This is a function to continue the user-opened exchange with remote nodes even when the QE71's open request signals (Y8 to YF) or initial request (Y19) are turned off.
- 2 After the initial processing is complete from the PLC CPU as shown in Item 5.2, and after successfully completing the open processing with the setting indicated in Items 5.2.2 and 16.2, data exchange can be performed while the PLC CPU is at the stop state.
- 3 Using this function, data exchange from remote nodes after the QE71 open request signals (Y8 to YF) or initial request signal (Y19) are turned off are continued in the following manner:
 - ① Protocol
The protocol when the corresponding communication line was opened by the PLC CPU (TCP/IP or UDP/IP) is used.
 - ② Exchange data code
The code (binary or ASCII) specified by the QE71's exchange condition setting switch (SW2:data code setting) when the PLC CPU was initial processed is used.
- 4 The functions supported with the data exchange function while the PLC CPU is at the stop state when the open request signals (Y8 to YF) or initial request signal (Y19) from the PLC CPU are as follows:

Data exchange function	Data exchange while PLC CPU is stop
Fixed buffer exchange (with procedure/without procedure)	Not possible
Random access buffer exchange	Possible
Read/write exchange in the PLC CPU	Possible

16.2 Setting for Continuing Data Exchange

The setting to use the data exchange functions while the PLC CPU is at the stop state is described. Item 16.4 describes the relationship between this setting and the data exchange while the PLC CPU is at the stop state.

1 Setting method

The setting to use the data exchange functions while the PLC CPU is at the stop state is made using the exchange instruction area during STOP in the buffer memory (address 103 (67H)).

2 Setting value for the exchange instruction area during STOP (Default value=0H (0))

..... Address 103 (67H)

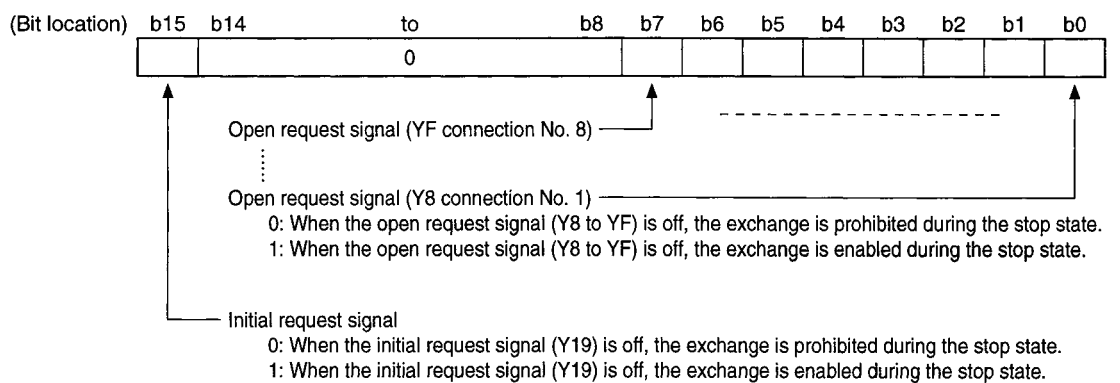

3 Specification of the setting value to the exchange instruction area during STOP

To continue exchange after the initial request signal (Y19) and open request signals (Y8 to YF) are turned off because the PLC CPU is stopped, etc., turn on the bit 15 of the exchange instruction area during STOP.

(Example) To continue exchange between connections No.1 and No.2 after the initial request signal (Y19) and open request signal (Y8, Y9) are turned off, set "8003H".

Point

- (1) When continuing the exchange with remote nodes while the PLC CPU is at the stop state, always set the bit 15 of the above exchange instruction area during STOP to "1 (on)".
- (2) When continuing the exchange when the initial request signal (Y19) is on and the open request signal (Y8 to YF) is turned from on to off, turn on the bit for corresponding connection No. of the exchange instruction area during STOP.

(Example) To continue the exchange between connections No. 1 and No. 2 when the initial request signal (Y19) is on and the open request signals (Y8, Y9) are off, set "0003H".

16.3 Relationship Between the Setting and the Data Exchange When the PLC CPU is at the Stop State

When the initial processing and open processing from the PLC CPU are completed, the setting for data exchange while the PLC CPU is at the stop state becomes valid.

After the setting becomes valid, data exchange can continue with the QE71 while the PLC CPU is at the stop state even when the following occurs:

- PLC CPU is switched to the stop state
- The QE71 initial request signal (Y19) and open request signals (Y8 to YF) are turned off.

The relationship between the setting for data exchange while the PLC CPU is at the stop state, the I/O signals to/from the PLC CPU (initial request signals and open request signals), and data exchange performed is described below:

A general example is indicated in the following page.

- ① If exchange is enabled in the exchange instruction area during STOP in the buffer memory (address 103 (67H)), data exchange is possible when the PLC CPU is at the stop state.
- ② The change (on to off) of the initial request signal (Y19) or open request signal (Y8 to YF) corresponding to the exchange-during-stop enabled bit is ignored.

When the exchange is enabled during stop in the exchange instruction area during STOP (address 103 (67H)), the signals change and the QE71 action correspond after that shown in next page:

	QE71 action	
	From off to on	From on to off
Initial request signal (Y19)	Initial processing is performed. (*1)	End processing is not performed.
Open request signals (Y8 to YF)	Open processing is performed. (*1)	Close processing is not performed.

*1 Only for the first ON

Point

When the exchange instruction area during STOP setting in the buffer memory is at the default value (address 103(67H)=0H), data exchange cannot be performed while the PLC CPU is at the stop state.

Perform the initial processing, open processing, close processing and end processing according to the procedures described in Items 5.1 to 5.4 to perform data exchange.

1 When the communication circuit is opened by a setting to allow data exchange through connection No. 1 while the PLC CPU is stopped

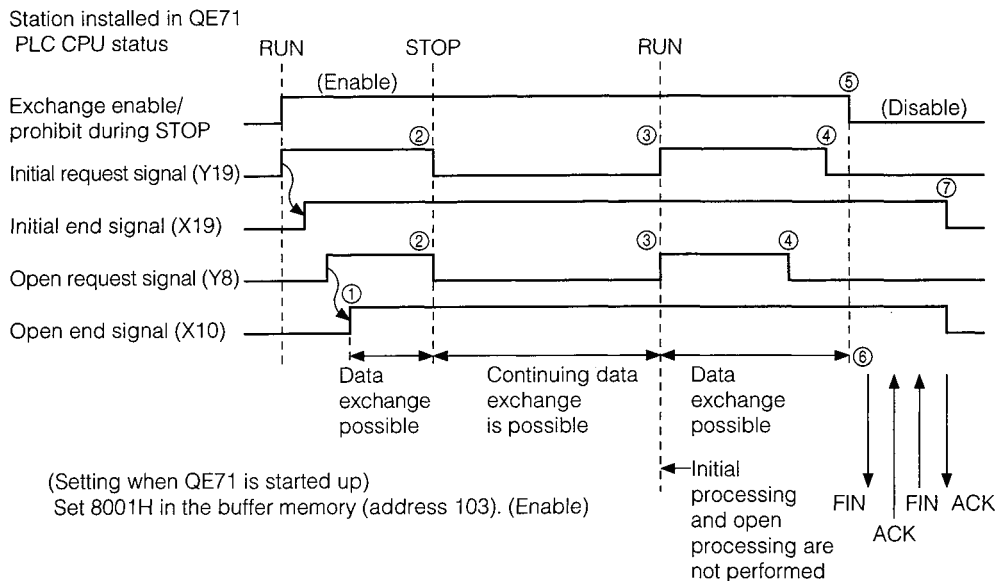

- ① Data exchange with a remote node is made possible by turning on the open end signal (X10). (Fixed buffer exchange, random access buffer exchange, and exchange of read/write data in the PLC CPU are possible.)
- ② The PLC CPU of the station installed in the QE71 enters the STOP status and the initial signal (Y19) and open request signal (Y8) turn off. Close processing and end processing are not performed because exchange enable during STOP is set. Data exchange can be continued. (Random access buffer exchange and exchange of read/write data in the PLC CPU are possible.)
- ③ The PLC CPU of the station installed in the QE71 enters the RUN status and the initial request signal (Y19) and open request signal (Y8) turn on. Initial processing and open processing are not conducted because exchange enable during STOP is set. Data exchange can be continued. (Fixed buffer exchange, random access buffer exchange, and exchange of read/write data in the PLC CPU are possible.)
- ④ The open request signal (Y8) and initial request signal (Y19) are turned off. Close processing and end processing are not conducted because exchange enable during STOP is set. Data exchange can be continued. (Random access buffer exchange and exchange of read/write data in the PLC CPU are possible.)
- ⑤ Change the setting to exchange prohibited during STOP. Set the buffer memory (address 103) to 0000H.
- ⑥ Communication circuit close processing is conducted after the open request signal (Y8) is turned off after the setting has been changed to exchange prohibit during STOP.
- ⑦ End processing is conducted after the initial request signal (Y19) is turned off after the setting is changed to exchange prohibit during STOP.

2 When initial processing and open processing are reperformed when the setting for data exchange while the PLC CPU is stopped is changed midway for connection No. 1

(Changed from exchange data while the PLC CPU is stopped to do not exchange data while the PLC CPU is stopped.)

- (a) When the open request signal (Y8) and the initial request signal (Y19) are turned off after the setting is changed to exchange prohibited

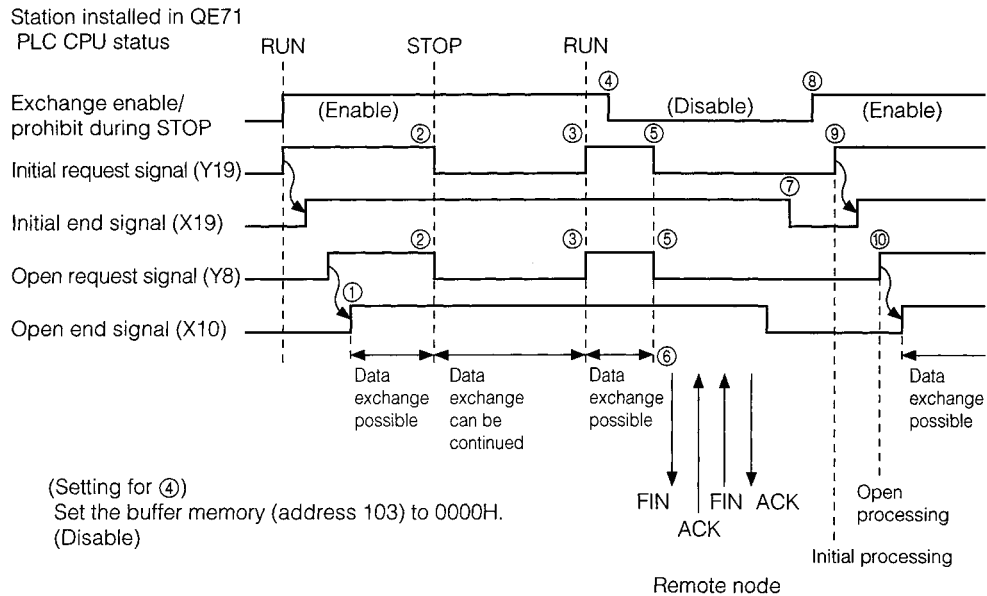

- ① Data exchange to a remote node becomes possible by turning the open end signal (X10) on. (Fixed buffer exchange, random access buffer exchange, and exchange of read/write data in the PLC CPU are possible.)
- ② The PLC CPU in the station installed in the QE71 enters the STOP status and the initial request signal (Y19) and the open request signal (Y8) turn off. Close processing and end processing are not conducted because exchange enable during STOP is set. Data exchange can be continued. (Random access buffer exchange and exchange of read/write data in the PLC CPU are possible.)
- ③ The PLC CPU in the station installed in the QE71 enters the RUN state and the initial request signal (Y19) and open request signal (Y8) are turned on. Initial processing and open processing are not conducted because the exchange enable during STOP is set. Data exchange can be continued. (Fixed buffer exchange, random access buffer exchange, and exchange of read/write data in the PLC CPU are possible.)
- ④ Change the setting to exchange prohibited during STOP. Set the buffer memory (address 103) to 0000H. Close processing and end processing are not conducted because the initial request signal (Y19) and open request signal (Y8) are turned on. Data exchange can be continued. (Fixed buffer exchange, random access buffer exchange, and exchange of read/write data in the PLC CPU are possible.)

- ⑤ The initial request signal (Y19) and open request signal (Y8) are turned off.
- ⑥ Close processing is conducted because the exchange prohibited during STOP is set.
- ⑦ End processing is conducted for the same reason as in ⑥ above.
- ⑧ Change the setting to exchange enable during STOP. Set the buffer memory (address 103) to 8001H. Initial processing and open processing are not conducted because the initial request signal (Y19) and open request signal (Y8) are turned off.
- ⑨ The initial request signal (Y19) is turned on to reconduct initial processing. QE71 initial processing is conducted.
- ⑩ The request signal (Y8) is turned on to reconduct open processing. Open processing of the communication line with the remote node is conducted. (Fixed buffer exchange, random access buffer exchange, and exchange of read/write data in the PLC CPU are possible.)

- (b) When changing the setting to exchange prohibited after turning the open request signal (Y8) and initial request signal (Y19) off

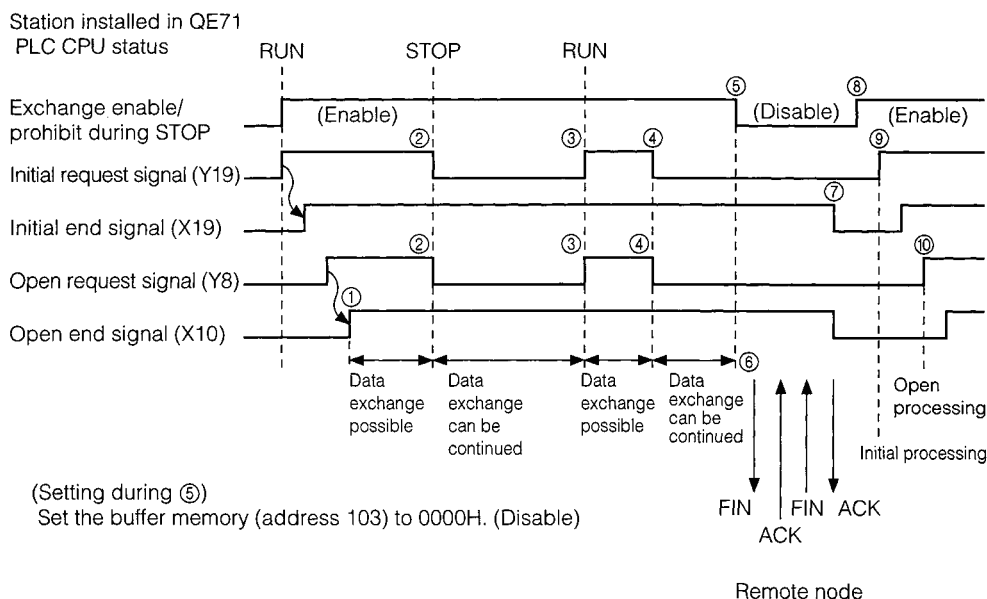

- ① Data exchange with the remote node can be conducted by turning the open end signal (X10) on. (Fixed buffer exchange, random access buffer exchange, and exchange of read/write data in the PLC CPU are possible.)
- ② The PLC CPU of the station installed in the QE71 enters the STOP status, and the initial request signal (Y19) and open request signal (Y8) are turned off. Close processing and end processing are not conducted because exchange enable during STOP is set. Data exchange can be continued. (Random access buffer exchange and exchange of read/write data in the PLC CPU are possible.)
- ③ The PLC CPU in the station installed in the QE71 enters the RUN status and the initial request signal (Y19) and open request signal (Y8) are turned on. Initial processing and open processing are not conducted because the exchange enable during STOP is set. Data exchange can be continued. (Fixed buffer exchange, random access buffer exchange, and exchange of read/write data in the PLC CPU are possible.)
- ④ The initial request signal (Y19) and open request signal (Y8) are turned off. Close processing and end processing are not conducted because exchange enable during STOP is set. Data exchange can be continued. (Random access buffer exchange and exchange of read/write data in the PLC CPU are possible.)
- ⑤ Change the setting to exchange prohibited during STOP. Set the buffer memory (address 103) to 0000H.
- ⑥ Communication line close processing is conducted after the setting is changed to exchange prohibit during STOP because the open request signal (Y8) is turned off.

- ⑦ End processing is conducted because the initial request signal (Y19) is turned off after the setting is changed to exchange prohibited during stop.
- ⑧ Change the setting to exchange enabled during STOP. Set the buffer memory (address 103) to 8001H.
- ⑨ The initial request signal (Y19) is turned on to reconduct initial processing. QE71 initial processing is conducted.
- ⑩ The open request signal (Y8) is turned on to reconduct open processing. Open processing of the communication line with the remote node is conducted. (Fixed buffer exchange, random access buffer exchange, and exchange of read/write data in the PLC CPU are possible.)

- 3** When a close request is received from the partner remote node when data is being exchange because the setting allows data exchange through connection No. 1 while the PLC CPU is stopped.

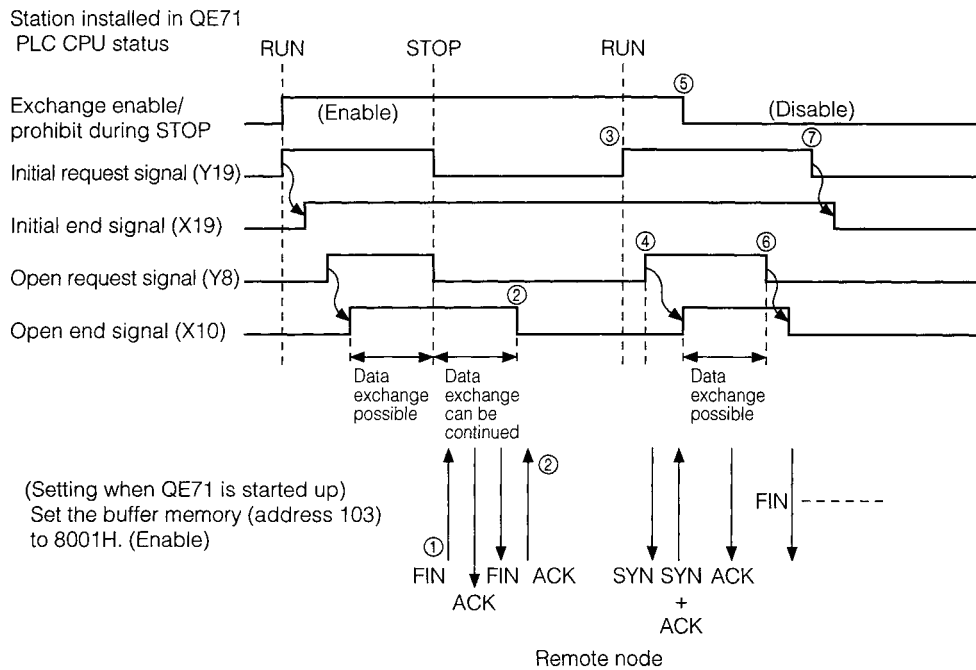

- ① A close request is received from the partner remote node when data is exchanged with the remote node using the data exchange function when the PLC CPU is stopped.
- ② Close processing is conducted in the open end signal (X10) is turned off. Data exchange cannot be conducted.
* FIN is transmitted even if the open request signal (Y8) is turned off.
- ③ The PLC CPU of the station installed in QE71 enters the RUN status and the initial request signal (Y19) is turned on. Initial processing is not conducted because the exchange enable during STOP is set.
- ④ Open request signal (Y8) turns on and open processing is conducted and then the open end signal (X10) is turned on. Data exchange with the remote node becomes possible. (Fixed buffer exchange, random access buffer exchange, and exchange of read/write data in the PLC CPU are possible.)
- ⑤ Change the setting to exchange prohibited during STOP. Set the buffer memory (address 103) to 0000H. Close processing and end processing are not conducted because the initial request signal (Y19) and open request signal (Y8) are turned on. Data exchange can be continued.
- ⑥ Communication line close processing is conducted because the open request signal (Y8) turns off after the setting is changed to exchange prohibited during STOP.
- ⑦ End processing is conducted when the initial request signal (Y19) turns off after the setting is changed to exchange prohibited during STOP.

TROUBLESHOOTING SECTION

The troubleshooting section explains about the error codes corresponding to errors, error contents, error processing, and trouble shooting flow when trouble occurs during Ethernet interface module use.

17. TROUBLESHOOTING

This section explains about trouble that occurs when using the Ethernet interface module and covers error codes, error description, error processing, and troubleshooting flow for errors detected by the QE71.

When trouble occurs that prevents normal exchange between the QE71 and a remote node then the problem must be limited to whether the cause occurred on the QE71 end, in the line, or at the remote node end.

Whether or not the error occurs on the QE71 side or the checking method for the error contents are described in Item 17.3. Refer to them as required.

Remarks

When a line error, etc., occurs when equipment from different manufacturers is connected, we ask that the user use a line analyzer, etc., to determine the location of the problem.

17.1 List of Error Codes

This section explains about the error codes, error description, and error processing that are generated for each process when data is exchanged between the QE71 and a remote node, and access request/exchange request from local station QnACPU.

The types of errors that occur are shown below.

	Error type	Description	Error code storage buffer memory address	Reference item
1	Errors that occur during initial processing	<ul style="list-style-type: none"> Setting value error Initial processing error 	69H (105) * Exchange state storage area	Item 17.1.3
2	Errors that occur during open processing	<ul style="list-style-type: none"> Setting value error Open processing error 	7CH (124) ... * Exchange state storage area	
3	Errors that occur during fixed buffer transmission to remote node	<ul style="list-style-type: none"> Specified data error Transmission error 	7DH (125) ... 7EH (126) ... * Exchange state storage area	
4	Errors that occur during fixed buffer exchange with remote node	<ul style="list-style-type: none"> Specified data error Exchange error (excluding 3 above) 	7EH (126) ... * Exchange state storage area	
5	Errors that occur during exchange with remote node * Errors return to the request originating remote node	<ul style="list-style-type: none"> Errors returned by fixed buffer exchange (End code) Errors returned by random access buffer exchange (End code) 	—	Item 17.1.1
		<ul style="list-style-type: none"> Errors returned by reading/writing data in the PLC CPU 		—
		End code during QE71 command use		Item 17.1.3
		End code during E71 command use		Item 17.1.1
		Error code during E71 command use		Item 17.1.2
6	Among the errors that occur in the exchange with remote nodes (including the causes indicated in the description column), error which makes the error code stored in the error log area	<ul style="list-style-type: none"> Specified data error Errors where the place of origin of the error cannot be determined Errors occurring during random access buffer exchange, reading/writing data in the PLC CPU 	E5H (229)... * Error log area	Item 17.1.3
7	Error which occurs in the exchange using the file transfer function (FTP) with a remote node (Response code)	<ul style="list-style-type: none"> Specified data error Exchange error, etc. 		Item 13.6.3
8	Error which occurs in the exchange started by the data link instruction sent by the local station QnACPU.	<ul style="list-style-type: none"> Specified data error Exchange error 	(Not stored)	Item 17.1.3
9	Error which occurs in the EEPROM read/write for the QE71 from the local station QnACPU.	<ul style="list-style-type: none"> Read processing errors Write processing errors Registration value errors EEPROM errors 	72H (114) 73H (115) * Exchange state storage area	Item 17.1.3

17.1.1 End Codes Returned to the Remote Node During Data Exchange

This section explains about the end code that is attached to the response during fixed buffer exchange, random access buffer exchange, and reading and writing data in the PLC CPU.

An explanation of the error codes that are added to the response during reading and writing of data in the PLC CPU using E71 commands is given in Item 17.1.2.

An explanation of the end codes (error codes) stored in the QE71's buffer memory is given in Item 17.1.3.

End code	Description	Processing								
00H	Normal end	—								
02H	<ul style="list-style-type: none"> There is an error in the specification of the device range to read/write. 	<ul style="list-style-type: none"> Check and correct the specified head device and number of the head device. 								
50H	<ul style="list-style-type: none"> When the codes are other than those prescribed by the subheader commands and responses. <table border="1" style="margin-left: 20px;"> <thead> <tr> <th>Exchange processing</th> <th>Commands/responses</th> </tr> </thead> <tbody> <tr> <td>Fixed buffer exchange</td> <td>60H</td> </tr> <tr> <td>Random access buffer exchange</td> <td>61H, 62H</td> </tr> <tr> <td>Reading/writing data in the PLC CPU</td> <td>00H to 3CH</td> </tr> </tbody> </table> <ul style="list-style-type: none"> During fixed buffer exchange, when the actual data quantity is less than the data length setting, the remaining data is determined to be second data and processed. In this case, a subheader command undefined error will occur. 	Exchange processing	Commands/responses	Fixed buffer exchange	60H	Random access buffer exchange	61H, 62H	Reading/writing data in the PLC CPU	00H to 3CH	<ul style="list-style-type: none"> Check in correction of the set commands and responses at the remote node. <ul style="list-style-type: none"> The QE71 automatically adds the commands and responses, so the user does not need to set these. Refer to the remarks in Item 17.1.3. Check and correct the data length.
Exchange processing	Commands/responses									
Fixed buffer exchange	60H									
Random access buffer exchange	61H, 62H									
Reading/writing data in the PLC CPU	00H to 3CH									
51H	<ul style="list-style-type: none"> For random access buffer exchange, the specified head address from the remote node is set outside the range of 0 to 6143. 	<ul style="list-style-type: none"> Check and correct the specified head address. 								
52H	<ul style="list-style-type: none"> For random access buffer exchange, <u>the specified head address from the remote node + number of data words (set during read) exceeds the range of 0 to 6143.</u> The data (text) for the specified number of words cannot be transmitted in one frame. (The transmission/reception data length value or text amount is not within the acceptable range.) 	<ul style="list-style-type: none"> Check and correct the head address and number of data words. Correct the number of read/write points. 								
54H	<ul style="list-style-type: none"> When the data code setting using the exchange condition setting switch (SW2) of the QE71 is set to ASCII code, ASCII code data that cannot be converted to binary code by the remote node was transmitted. 	<ul style="list-style-type: none"> Check and correct the remote node transmission data. 								
55H	<ul style="list-style-type: none"> When the CPU exchange timing setting is set to write not possible during RUN using the exchange condition setting switch (SW7) of the QE71, and the data write request from the remote node was made while the PLC CPU was running. A request from a remote node to write a parameter, sequence program, or microcomputer program was received while the PLC CPU was running. (Not related to the on/off state of the exchange condition setting switch (SW7) of the QE71.) 	<ul style="list-style-type: none"> Conduct data write while the SW7 is on (write allowed during RUN). However, parameters, sequence programs, and microcomputer programs cannot be written while the CPU is running. Write the data after stopping the PLC CPU. 								
56H	<ul style="list-style-type: none"> There is a device specification error from a remote node. 	<ul style="list-style-type: none"> Correct the device specification. 								

End code	Description	Processing
57H	<ul style="list-style-type: none"> The number of command points specified by the remote node exceed that of the maximum processing number of points for each process (number of points processed during one exchange). The head address (head address No., head step No.) to the specified number of points, exceeds the maximum address for each process (device No., step No.). 	<ul style="list-style-type: none"> Correct the specified number of points and the head address (device No., step No.).
	<ul style="list-style-type: none"> The command byte length is longer than that prescribed. During data write, the specified write data number of points is different from the number of points specified value. 	<ul style="list-style-type: none"> Check the command data length and reset the data.
	<ul style="list-style-type: none"> There was a monitor request even though monitor data is not registered. 	<ul style="list-style-type: none"> Conduct monitor data registration.
	<ul style="list-style-type: none"> When a microcomputer program was read/written it was specified beyond the parameter setting range's final address. 	<ul style="list-style-type: none"> Reading and writing cannot be performed after the final address. Correct the specified address.
	<ul style="list-style-type: none"> During the extension file register block No. specification, a range of block No. were specified that exceed the corresponding memory cassette's capacity. 	<ul style="list-style-type: none"> Correct the block No.
58H	<ul style="list-style-type: none"> The command head address from a remote node (head device No., head step No.) from a remote node that exceeds the specifiable range was set. A microcomputer program and file register (R) read/write that is outside the PLC CPU's parameter settings was specified. 	<ul style="list-style-type: none"> Correct all processing to values in the specifiable range.
	<ul style="list-style-type: none"> The extension file register block No. specifications are for blocks that do not exist. 	<ul style="list-style-type: none"> Correct the block No.
	<ul style="list-style-type: none"> A file register (R) is specified for the A1(N) CPU. 	<ul style="list-style-type: none"> The A1(N) CPU cannot use file registers.
	<ul style="list-style-type: none"> A word device is specified using bit device commands. The bit device's head No. is specified at values other than multiples of 16 using word device commands. 	<ul style="list-style-type: none"> Correct the commands or the specified device.
59H	<ul style="list-style-type: none"> An extension file register read/write request was made to the A1(N) CPU. 	<ul style="list-style-type: none"> The A1(N) CPU cannot use extension file registers.
5BH	<ul style="list-style-type: none"> Exchange cannot be done between the PLC CPU and the QE71. The PLC CPU cannot process requests from remote nodes. 	<ul style="list-style-type: none"> Repair the error location by adding an error code (Refer to Item 17.1.2) after the end code.
60H	<ul style="list-style-type: none"> The exchange time between the QE71 and the PLC CPU exceeds the ACPU monitoring timer value. 	<ul style="list-style-type: none"> Lengthen the ACPU monitoring timer value.
A0H to FFFFH	<ul style="list-style-type: none"> All end code error descriptions, and error processing is the same as the error code (A0H to FFFFH) stored in the buffer memory. Check the processing using the explanation portion for the corresponding code shown in Item 17.1.3. 	

17.1.2 Error Codes Returned to the Remote Node by Reading/Writing Data in the PLC CPU Using E71 Commands

This section explains about the error codes that are attached to the responses to the data read/writes in the PLC CPU using E71 commands. (Error codes are only attached when the end code is "5B".)

End codes (error codes) with responses attached are described in Item 17.1.1.

The end code (error code) stored in the QE71's buffer memory is described in Item 17.1.3.

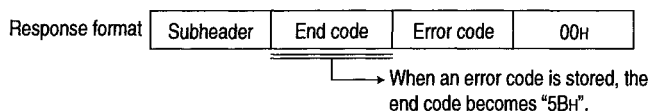

Error code (Hexadecimal)	Error item	Error description	Processing method
10H	PLC No. error	The PLC No. station does not exist. (1) The PLC No. specified by a command is other than the station No. specified for the local station "FF" and the MELSECNET link parameter settings.	(1) Change the PLC No. to the local station's "FF" or set station No. using the link parameter and reconduct the exchange.
11H	Mode error	Exchange defect between the QE71 and PLC CPU (1) After a request from a remote node has been received normally by the QE71, for some reason (noise, etc.) normal exchange cannot be conducted between the QE71 and the PLC CPU.	(1) Reconduct the exchange. If an error occurs again, check for noise, etc., and then reconduct exchange with the QE71.
12H	Special functions module specification error	Special Functions Module Error (1) There is no buffer memory with an exchangeable special functions module in the location specified for the special functions module No. (For example, the location has an I/O module or a vacant slot in the location.)	(1) Change the control procedure specified data contents, or change the special functions module installation position and reconduct exchange.
18H	Remote error	Remote RUN/STOP can not be conducted. Remote STOP/PAUSE has already been conducted by another module (another QE71, etc.).	(1) Check if remote STOP/PAUSE is working or not from other modules, perform a cancellation, and reconduct the exchange.
1FH	Device error	There is an error in the device specification.	(1) Review the specified device. (2) Do not perform the access to the device not existed.
20H	Link error	The request destination CPU module is disconnected from the data link.	Check if the PLC CPU of the station No. specified in the PLC No. is parallel off. After removing the parallel off cause, reconduct exchange.
21H	Special functions module bus error	The special function module's memory cannot be accessed. (1) There is a control bus error with the special functions module. (2) The special functions module is damaged.	There is a hardware error in the PLC CPU, base module, special functions module, or QE71. Consult with your nearest, agency, or branch office.

17.1.3 Error Codes Stored in the Buffer Memory

This section describes the errors and explains the error processing when an error occurs during data exchange processes between the QE71 and a remote node and the error code is stored in the QE71's buffer memory.

The storage destination column in the error code table shows the buffer memory where the corresponding error code is stored. The handling of the explanation names used in the storage destination column and the buffer memory error code storage area is as follows. (Error codes for which there is no symbol in the storage destination are the error codes that are returned to the remote node.)

Note that the buffer memory may store error codes of the messages returned from the remote node. For error codes not shown in this manual, refer to the manual of the remote node and check the returned messages.

Explanation name	Buffer memory	Buffer memory address
Initial	Initial error code area	69H (105)
Open	Open error code area	7CH (124) ...
Fixed transmission	Fixed buffer transmission error code area	7DH (125) ...
Connection	Connection end code · Error log area	7EH (126) ...
Error code	Error code · End code area	E5H (229) ...
Read	EEPROM read results area	72H (114)
Write	EEPROM write results area	73H (115)
Data link	(Data link command $\text{\textcircled{S}}$ +1)	—

Error code	Error description	Error processing	Storage destination								
			Initial 69H	Open 7CH	Fixed Transmission 7DH	Connection 7EH	Error Code E5H	Read 72H	Write 73H	Data link —	
02H	Each error code's error description and error processing is the same as for the error codes (0001H to 0060H) that are returned to the remote node. Check and conduct the processing described in the explanation portions for the corresponding error code described in Item 17.1.1.						○				○
0050H						○	○				
0051H							○				
0052H					○	○	○				
0054H						○	○				
0055H							○	○			
0056H							○	○			
0057H							○	○			
0058H							○	○			
0059H							○				
005BH			Read and processing of error codes and end codes area.				○	○			
0060H							○	○			

Error code	Error description	Error processing	Storage destination							
			Initial 69H	Open 7CH	Fixed Transmission 7DH	Connection 7EH	Error Code E5H	Read 72H	Write 73H	Data link -
00A0H	A request that cannot be specified for corresponding connection.	<ul style="list-style-type: none"> Change the request contents. Correct the usage available setting during open processing. (Refer to Item 5.5.1 1) 				○				
00A1H	The request contents cannot be analyzed because the text portion length or request data length is too short.	Change the text portion length and the QnA header request data length and after correction retransmit to the QE71. (Refer to Item 10.1.2 3 (a))				○				
00A2H	A request that cannot be processed.	Correct the request contents and command.					○			
3E8H to 3FFFH	(PLC CPU detected error)	Refer to Troubleshooting of the QnACPU user's manual and take necessary measures.				○	○			
4000H to 4FFFH	(PLC CPU detected error)	Refer to Appendix of the QnACPU user's manual (detailed edition) and take necessary measures.				○	○			
7000H to 7FFFH	(Error detected by serial communication or similar module)	Refer to the serial communication module user's manual or like and take necessary measures.					○			
B000H to BFFFH	(CC-Link module detected error)	Refer to the CC-Link system master/local module user's manual and take necessary measures.					○			
C001H	<ul style="list-style-type: none"> There is a QE71 IP address setting value error during initial processing. There is a subnet mask field setting value error when the router relay function is used. 	Correct the IP address. Make the class A, B, C. (Refer to Item 5.2.2 1 and Item 11.3) <ul style="list-style-type: none"> Correct the subnet mask. (Refer to Item 11.2) 	○				○			
C002H	There is a setting value outside the allowable range in the timer setting values during initial processing.	Review and correct the timer setting values during initial processing. (Refer to Item 5.2.2 3 to 11)	○				○			
C003H	The automatic open UDP port No. setting value is outside the allowable range during initial processing.	<ul style="list-style-type: none"> Correct the automatic open UDP port No. (Refer to Item 5.2.2 12) 	○				○			
C004H	There is an error in the subnet mask field setting value.	Correct the subnet mask and reconduct initial processing. (Refer to Item 11.2)	○				○			
C005H	<ul style="list-style-type: none"> There is an error in the router relay function's default router IP address setting value. The default router IP address network address (network address after the subnet mask) is different than the local station QE71's IP address network address. 	<ul style="list-style-type: none"> Correct the default router IP address and reconduct initial processing. (Refer to Item 12.4 1) Make it the same as the local station QE71's network address. (Refer to 11.2) 	○				○			
C006H	There is an error in the router relay function's subnet address setting value.	Correct the subnet address and reconduct initial processing. (Refer to Item 12.4 3)	○				○			

Error code	Error description	Error processing	Storage destination								
			Initial 69H	Open 7CH	Fixed Transmission 7DH	Connection 7EH	Error Code E5H	Read 72H	Write 73H	Data link -	
C007H	<ul style="list-style-type: none"> There is an error in the router relay function router IP address settings value. The router IP address network address (network address after the subnet mask) and the local station QE71's IP address network address are different. 	<ul style="list-style-type: none"> Correct the router IP address and reconduct initial processing. (Refer to Item 12.4 4.) Make it the same as the local station QE71's IP address network address. (Refer to Item 11.2) 	○					○			
C010H	There is an error in the QE71's port No. settings value during open processing.	Correct the port No. (Refer to Item 5.5.1 2) (c)①)	○	○				○			
C011H	There is an error in the partner remote node's port No. settings value during open processing.	Correct the port No. (Refer to Item 5.5.1 2) (c)③)		○	○			○			
C012H	A port No. that is already being used for the open end connection on the TCP/IP has been set.	Review and correct the QE71 and partner remote node port No. (Refer to Item 5.5.1 2)		○				○			
C013H	The port No. that is used for the open end connection has been set for the UDP/IP open processing.	Review and correct the QE71's port No. (Refer to Item 5.5.1 2) (c)①)		○				○			
C014H	The QE71 initial processing and open processing have not ended.	Conduct initial processing and open processing. (Refer to Items 5.1 to 5.5)			○			○			
C015H	There is an error in the remote node's IP address settings value during open processing.	<ul style="list-style-type: none"> Correct the IP address. Make the class A, B, C. (Refer to Item 5.5.1 2) (c)② and Item 11.3) 		○	○			○			
C016H	Open processing has already been conducted for the pairing open connection (or the next connection).	<ul style="list-style-type: none"> Check if both of the connections used for the pairing open have had open processing conducted. Review the pairing open combination. (Refer to Item 5.5.1 1) (b)③) 		○				○			
C017H	The connection has not been established in the open processing of the TCP connection.	<ul style="list-style-type: none"> Check if the partner remote node is operating. Check if open processing has been conducted for the partner remote node end. Correct the exchange parameter usage availability setting value. (Refer to Item 5.5.1 1) Review the open method for the QE71 port No., remote node IP address/port No. Check if the connection cable is loose. Check if there is a problem with the connection to the transceiver or the terminator connection. 		○				○			
C018H	There is an error in the IP address setting value on the partner remote node end. * FFFFFFFFH cannot be set for the IP address when using TCP.	Correct the IP address. (Refer to Item 5.1.1 2) (c)②)		○				○			
C020H	The data length exceeds the allowable range.	<ul style="list-style-type: none"> Correct the data length. Divide the transmission if the transmitted data amount exceeds the proscribed amount. 			○			○			

Error code	Error description	Error processing	Storage destination								
			Initial 69H	Open 70H	Fixed Transmission 7DH	Connection 7EH	Error Code E5H	Read 72H	Write 73H	Data link -	
C021H	An error end response is received for the transmission from the fixed buffer.	Read the response end code from the connection end code error log area and take appropriate actions.			○		○				
C022H	<ul style="list-style-type: none"> The response is not received within the response monitoring timer value. The corresponding connection was closed during waiting for a response. 	<ul style="list-style-type: none"> Check if the partner remote node is operating. Review and correct the response monitoring timer value. (Refer to Item 5.2.2 8) Check the open status of the corresponding connection. 			○		○				
C023H	<ul style="list-style-type: none"> The open processing for the corresponding connection is not completed. The corresponding connection was closed. 	Perform open processing for the corresponding. (Refer to Item 5.5)			○		○				
C030H	A transmission error has occurred.	<ul style="list-style-type: none"> Check if the transceiver and the partner remote node are operating. * Use a transceiver for which SQE tests can be conducted. There are times when a packet can enter into the line, so transmit after the voluntary time has passed. Check if the connection cable is loose. Check if there are problems with the connection to the transceiver and the terminator connection. Conduct a self diagnostic test to see if there is a problem with the QE71. 		○	○		○				
C031H	A transmission error has occurred.				○	○		○			
C032H	A TCP ULP time out error occurs during TCP/IP exchange. (ACK is not returned from the remote node)	<ul style="list-style-type: none"> Check if the partner remote node is operating. Correct the TCP ULP time out value and reconduct initial processing. (Refer to Item 5.2.2 3) A packet can enter into the line, so transmit after the voluntary time has passed. Check if the connected cable is loose. Check for trouble with the connection to the transceiver and with the terminator connection. 		○	○		○				
C033H	The set IP address remote node does not exist.	<ul style="list-style-type: none"> Review and correct the partner remote node IP address and the Ethernet address. (Refer to Item 5.5.1 2) (c) 2 4) Set a default value when the partner remote node has ARP functions and set the partner remote node Ethernet address when it does not have ARP functions. Check if the partner remote node is operating. Packets can enter into the line, so transmit after the voluntary time has passed. Check if the connection cable is loose. Check if there is a problem with the connection to the transceiver or with the terminal connection. 		○	○		○				

Error code	Error description	Error processing	Storage destination							
			Initial 69H	Open 7CH	Fixed Transmission 7DH	Connection 7EH	Error Code E5H	Read 72H	Write 73H	Date link —
C035H	The existence of the partner remote node could not be confirmed within the response monitoring timer value.	<ul style="list-style-type: none"> Check if the partner remote node is operating. Review and change the existence check settings values. (Refer to Item 5.2.2 [9] to [11]) Check if the connection cable is loose. Check if there is a problem with the connection to the transceiver or the terminator connection. 		○	○		○			
C036H	The transmission processing cannot be conducted because the cable is not connected or wire breakage.	<ul style="list-style-type: none"> Check if the connection cable is loose. Check if there is a problem with the connection to the transceiver and the terminator connection. Conduct a loopback test (Refer to Item 10.9) and make sure the lines are normal. Conduct a self-diagnosis test and make sure the QE71 works normally. 					○			
C040H	<ul style="list-style-type: none"> All the data is not received within the response monitoring timer value. The data length portion of the data was not received. The rest of the message divided on the TCP/IP level was not received within the response monitoring timer value. 	<ul style="list-style-type: none"> Review and correct the exchange data's data length. Packets can enter into the line, so review and change the setting values during initial processing. (Refer to Item 5.2.2) Retransmit the same data from the partner remote node. 		○	○		○			
C041H	An error has occurred in the reception data check sum during TCP use.	<ul style="list-style-type: none"> Review the check sum transmitted by the partner remote node and transmit the correct value. Investigate the line's environment conditions. (Noise environment, distance between the line and power lines, and the equipment grounds) 			○		○			
C042H	An error occurs in the reception data check sum during UDP usage.				○		○			
C043H	An error occurs in the received IP packet header check sum.				○		○			
C044H to C048H	ICMP error packet is received.	<ul style="list-style-type: none"> Check if the partner remote node is operating. Check if the connection cable is loose. Check if there is a problem with the connection to the transceiver and the terminator connection. 			○		○			
C049H	ICMP error packet was received.	<ul style="list-style-type: none"> Check if the partner remote node is operating. A packet can enter into the line, so transmit after the voluntary time has passed. Check if the connection cable is loose. Check if there is a problem with the connection to the transceiver or with the terminator connection. 			○		○			
C04AH	ICMP error packet was received. (An IP set up time out has occurred on the partner remote node side.)	<ul style="list-style-type: none"> Correct the partner remote node IP combination timer value during existence time time out. 			○		○			

Error code	Error description	Error processing	Storage destination							
			Initial	Open	Fixed Transmission	Connection	Error Code	Read	Write	Data link
			69H	70H	7DH	7EH	E5H	72H	73H	—
C04BH	An IP set up time out error has occurred. (Time out occurred without the remainder of the	<ul style="list-style-type: none"> Check if the partner remote node is operating. Packets can enter into the line, so transmit from the remote node after the voluntary time has passed. Check if the connection cable is loose. Check if there is a problem with the connection to the transceiver and with the terminator connection. Correct the IP set up timer value and reconduct initial processing. (Refer to Item 5.2.2 [7]) 			○		○			
C04CH	Cannot transmit since no space is available in internal buffers such as IP header buffer.	<ul style="list-style-type: none"> Transmit the same data once again and confirm the response returned. 			○		○			
C04DH	<ul style="list-style-type: none"> An error occurred in the data length specified in the application data area of the message received by the QE71 during automatic open UDP port exchange/without procedure fixed buffer exchange. All of the reception data cannot be stored. 	<ul style="list-style-type: none"> Revise the data length. Revise the text size so that the text data is smaller than the reception buffer memory size. 				○	○			
C050H	ASCII code data that cannot be converted into binary code was received when the QE71's exchange condition setting switch (SW2) was on.	<ul style="list-style-type: none"> Set the exchange condition setting switch (SW2) to off, reboot the QE71, and reconduct exchange. Correct and transmit the transmission data received from the remote node. 			○		○			
C051H to C054H	The number of read/write points is outside the allowable range.	Correct the number of read/write points and reconduct transmission to the QE71.			○		○			
C055H	The number of file data read/write points is outside the allowable range.	Correct the number of read/write points (or number of bytes) and reconduct transmission to the QE71.			○		○			
C056H	<ul style="list-style-type: none"> The requested read/write exceeds the maximum address. The address is 0. 	Correct the head address and the read/write number of points and retransmit to the QE71. (So that the maximum address is not exceeded.)			○		○			
C057H	The requested data length and the character portion (text portion) number of data do not match.	Reconduct transmission to the QE71 after reviewing and correcting the text portion contents and the QnA header request data length. (Refer to Item 10.1.2 [3] (a))			○		○			
C058H	The reception data length after conversion from ASCII to binary and the character portion (text portion) number of data do not match.	Retransmit to the QE71 after review and correcting the text portion contents and the QnA header request data length. (Refer to Item 10.1.2 [3] (a))			○		○			
C059H	There is an error in the command or subcommand specification.	Review the request contents.			○		○			
C05AH	The QE71 cannot read from or write to the specified device.	Review the read/write device. (Refer to Item 10.2.1[3] and Item 10.2.11 [2])			○		○			
C05BH					○		○			
C05CH	There is an error in the request contents. (Only bit unit read/write to the word device, etc.)	Correct the request contents and retransmit to the QE71. (Correct the subcommand, etc.)			○		○			

Error code	Error description	Error processing	Storage destination							
			Initial 69H	Open 7CH	Fixed Transmission 7DH	Connection 7EH	Error Code E5H	Read 72H	Write 73H	Date link —
C05DH	Monitor registration has not been done.	<ul style="list-style-type: none"> Conduct monitor after monitor registration. 			○		○			
C05EH	The exchange time between the QE71 and the PLC CPU exceeds the CPU monitoring timer.	<ul style="list-style-type: none"> Lengthen the CPU monitoring timer. Check if the PLC CPU is operating normally. 			○		○			
C05FH	A request that cannot be executed by the subject PLC is received.	<ul style="list-style-type: none"> Correct the network No. and the PLC No. Correct the read/write request contents. 			○		○			
C060H	There is an error in the request contents. (There is an error in the data specification for the bit device, etc.)	Correct the request contents and retransmit to the QE71. (Correct the data, etc.)			○		○			
C061H	The request data length does not match the character portion (text portion) number of data.	Retransmit to the QE71 after reviewing and correcting the text portion contents and the QnA header request data length. (Refer to Item 10.1.2 [3] (a))			○		○			
C070H	The device memory extension specification cannot be done for the subject station.	Read and write without specifying an extension. <ul style="list-style-type: none"> Device memory extension specification is only possible for the QnACPU via the QE71 installed station and the MELSECNET/10. (Refer to Item 10.2.11 [2]) 			○		○			
C071H	The number of read/write device points for other than the QnACPU is too many.	Correct the number of read/write device points and retransmit to the QE71.			○		○			
C072H	There is an error in the request contents. (Bit unit read/write, etc., to a word device)	Check if the contents can be requested to the subject PLC CPU. Correct the request contents and retransmit to the QE71. (Correct the subcommand, etc.)			○		○			
C073H	It is a request that is not supported by the QE71 to the subject PLC CPU. (There is a double word access number of points specification to other than the QnACPU, etc.)	Review the request contents.			○		○			
C074H	There is a request that cannot be executed by the subject PLC CPU.	<ul style="list-style-type: none"> Correct the network No., PLC No. Correct the read/write request contents. 			○		○			
C080H	The partner IP address cannot be obtained in the MELSECNET/10 relay exchange or data command exchange.	<ul style="list-style-type: none"> Set the MELSECNET/10 Routing Information parameter to the QE71. Change the MELSECNET/10 relay exchange parameter Convert Format. 					○			○
C081H	The QE71 completion processing has been performed, but arrival cannot be confirmed for the data link command exchange. (Initial request signal is OFF)	Perform the QE71 completion processing after all exchange is complete.					○			○

Error code	Error description	Error processing	Storage destination							
			Initial 69H	Open 7CH	Fixed Transmission 7DH	Connection 7EH	Error Code E5H	Read 72H	Write 73H	Data link -
C082H	Exchange processing ended error in the following exchange. • Exchange with GPPW (UDP/IP) • MELSECNET/10(H) relay	<ul style="list-style-type: none"> Check to see if the relay station/partner stations are operating correctly. (No corrective action is needed for error when the exchange is being continued.) Confirm that there is no errors in the cable connections between the local station and partner stations. If some load is applied to the line, reduce the load. 					○			
C083H	Exchange processing ended abnormally in the data link command exchange.						○			
C084H	Exchange processing ended abnormally in the data link command exchange.	<ul style="list-style-type: none"> Check to see that the local station/relay station/partner stations are operating correctly. Confirm that there is no errors in the cable connections between the local station and destination stations. Increase TCP retransmission timer value. 					○			
C085H	<ul style="list-style-type: none"> The local station channel specified by the remote station in the data link command exchange is currently being used. The receiving station did not read the transmitted data. 	<ul style="list-style-type: none"> Re-execute the request from the remote station. Review the transmission timing. 					○			○
C086H	A message exceeding the message size that can be received was received.	<ul style="list-style-type: none"> Correct the size of the transmission message of the request origin station. 					○			
C087H	The IP address of the Station No. <-> IP information parameters is incorrect.	<ul style="list-style-type: none"> Set the IP address of the MELSECNET/10 relay exchange target device in the Station No. <-> IP information parameters. 					○			○
C090H	<ul style="list-style-type: none"> An error occurs during read from the EEPROM. An attempt to read a parameter area that is not registered was made. 	<ul style="list-style-type: none"> Register the correct parameter EEPROM. Read a correctly registered parameter. 					○	○		
C091H	An error occurs during write to the EEPROM.	<p>Re-execute.</p> <p>If the same error occurs again, then QE71 hardware error can be suspected. Although it is inconvenient, please consult with the branch office or agent nearest you regarding the problem.</p>					○		○	
C092H	An error occurs during read from the EEPROM.	Conduct read after registering parameters in the settable range to the EEPROM.					○	○		
C093H to C095H	An error occurs when system information is read from the EEPROM.	<ul style="list-style-type: none"> Turn off the QE71 installed station's power, reinstall the QE71, and reboot it up. Check if there is a problem in the connection between the QE71 and the base module. If the same error occurs again, a QE71 hardware error can be suspected. Although this is inconvenient, please discuss the details of the problem with the branch office or agent nearest you. 					○	○		
C0B2H	Insufficient free space in receive buffer of the relay station for MELSOFT connection or data link instruction, or the communication requested station. (Receive buffer full error)	<ul style="list-style-type: none"> Provide sufficient time between request intervals Reduce the number of request nodes. Wait for a response to the request and issue the next request after receiving the response. Review the time-out value. 					○			○
C0B3H	A request that cannot be processed is received from the PLC CPU.	<ul style="list-style-type: none"> Review the request details. Correct the network No. and PLC No. 					○			○

Error code	Error description	Error processing	Storage destination							
			Initial 69H	Open 7CH	Fixed Transmission 7DH	Connection 7EH	Error Code E5H	Read 72H	Write 73H	Data link -
C0B5H	Data which cannot be handled by the PLC CPU/QE71 was specified.	<ul style="list-style-type: none"> Review the request details. Cancel the current request. 					○			○
C0B6H	Out of channel number permissible range.	Specify 1 to 8 for the channel number.					○			○
C0B7H	The channel number currently being used was specified.	<ul style="list-style-type: none"> Change the channel number. Execute after the current exchange is complete. 					○			○
C0B8H	<ul style="list-style-type: none"> The network No. or PLC No. is outside the allowable range. There is an error in the response from PLC CPU 	<ul style="list-style-type: none"> Correct the network No. and the PLC No. Check if the PLC CPU is operating 					○			
C0B9H	The subject connection's open processing does not end.	<ul style="list-style-type: none"> Conduct open processing. Check that the partner remote node is operating. 			○		○			
C0BAH	A transmission request could not be received because close processing was being conducted in response to an open request signal being turned off.	Conduct open processing and transmission request.			○		○			
C0BCH	Specified communication line is closed.	<ul style="list-style-type: none"> Open the communication line. Review the target connection No. 			○	○	○			
C0BDH	Successive requests were accepted and transmission could not be performed.	<ul style="list-style-type: none"> Check if requests were made successively without waiting for a response. 			○	○	○			
C0C0H	The reception end check signal turned on because the reception end signal did not turn on.	Review and correct the program.					○			
C0C1H	A UDP transmission interval is too short.	<ul style="list-style-type: none"> Check if the transmission request signal (Y0 to Y7) is repeatedly turning on and off. Lengthen the transmission interval. 					○			
C0C5H	<ul style="list-style-type: none"> Transmission requests are sent to remote nodes with different classes and network address than that of the local station when the router relay function is not used. There is an error in the router relay parameter setting area. 	<ul style="list-style-type: none"> Set the router relay function for use and conduct initial processing. Set the correct data in the router relay parameter setting area and conduct initial processing. Correct the transmission destination remote node's IP address and conduct open processing. Check if the network address is correct. If the net ID is changed, reconduct initial processing. 		○	○		○			
C0C7H	QE71 system error occurred.	Reconduct initial processing.	○		○		○			
C0CBH	The next transmission request was conducted even though the transmission processing has not been completed.	Conduct the next transmission request after the transmission end signal turns on.			○		○			
C0D0H	There is an error in the data length specification.	Review the specified value of the data length.					○			○
C0D1H	There is an error in the resend counts specification.	Review the specified value of the resend count.					○			○
C0D2H	There is an error in the reached monitoring time specification.	Review the specified value of the reached monitoring time.					○			○

Error code	Error description	Error processing	Storage destination						
			Initial 69H	Open 70H	Fixed Transmission 7DH	Connection 7EH	Error Code E5H	Read 72H	Write 73H
C0D3H	The number of relay stations in the MELSECNET/10 relay exchange exceeded seven stations.	<ul style="list-style-type: none"> Check the specified value of the exchange destination. Review the setting value of the Station No. <-> IP information parameters between the host station and exchange destination Review the specification of the system. 					○		
C0D4H							○		
C0D5H	There is an error in the retry count specification	Review the specified value of the retry count.					○		○
C0D6H	There is an error in the network number or the station number specification.	<ul style="list-style-type: none"> Review the specified contents of the exchange destination. Review the specified value of the exchange destination. 					○		○
C0D7H	Initial processing has not been conducted.	Conduct the initial processing after normal completion.					○		○
C0D8H	The number of blocks exceeds the range.	Correct the specified value of the number of blocks.					○		
C0D9H	There is an error in the sub-command specified value.	19 Correct the specified value of the sub-command,					○		
C0DEH	The data are not received within the specified reached watchdog time.	<ul style="list-style-type: none"> Review the specified value of the reached watchdog time. Review the specified value of the channel number. Check the status of the relay station and the send origin station. 					○		○
C0F0H	An abnormality was detected in the QE71's RAM during a RAM test.	<ul style="list-style-type: none"> Perform a RAM test again. If an abnormality is detected again, the QE71's hardware may be abnormal. Contact your nearest Mitsubishi branch office or dealer with details of the problem. 					○		
C0F1H	An abnormality was detected in the QE71's ROM during a ROM test.	<ul style="list-style-type: none"> Perform a ROM test again. If an abnormality is detected again, the QE71's hardware may be abnormal. Contact your nearest Mitsubishi branch office or dealer with details of the problem. 					○		
C0F3H	A unit system error of the CPU was detected.	Remove the error cause of the local station's CPU.					○		
F000H to FFFFH	(The MELSECNET/10 network system detected error)	Refer to Chapter 10 of the MELSECNET/10 network system reference manual for QnA and take appropriate measures.					○	○	

Remarks

The exchange data is sometimes divided and exchanged because of local station and partner station buffer restrictions.

The divided reception data is restored (reassembled) by the QE71 and is transmitted by the fixed buffer or the random buffer. The restoration (reassembly) of the received data is done based on the data length in the exchange data.

The following shows the processing by the QE71 when the data length specified in the exchange data is incorrect:

1**When communication is performed using fixed buffer (with procedure) and random buffer**

(a) When the data length specified immediately after the subheader is smaller than the text data amount

- ① The data immediately following the text equivalent to the data length specified immediately after the subheader will be treated as the second message.
- ② Since the head of each message will be a subheader, the QE71 performs corresponding processing according to the subheader code.
- ③ If subheaders are other than the codes that can be handled by the QE71, the QE71 will send a response of abnormal completion to a remote node.

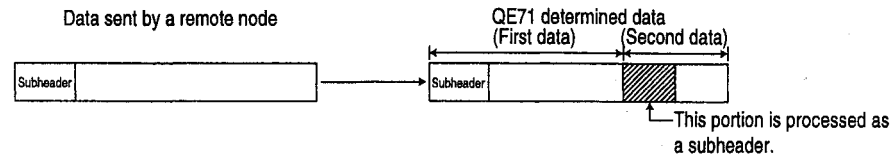

The response at this time is to return a code of 1 for the code's first bit position that was processed as a subheader.

For example, if the command subheader portion is 65H, the response subheader will become E5H.

(b) When the data length specified immediately after the subheader is larger than the text data amount

- ① The QE71 waits for the reception of the remaining insufficient data.
 - ② If the QE71 is able to receive the remaining data within the response monitor timer value, it performs corresponding processing according to the subheader code.
 - ③ If the QE71 is not able to receive the remaining data within the response monitor timer value, it performs the following processing:
 - Sends an ABORT (RST) instruction to a remote node and closes the line.
 - Notifies the PLC CPU side of the occurrence of an open error.
(Open error detection signal = ON)
 - Stores an error code in the open error code storage area.
- * The QE71 does not store error codes in the QE71's error log storage area.

As for the "data length" specified in the application data section of the message to be sent from a remote node to the QE71, specify the actual data size of the text section. The QE71 does not send text having a data length different from the specified data length to remote nodes.

2**When communication is performed using fixed buffer (non-procedure)**

Since no message data length is specified in non-procedure communication, the data received is stored in the receive buffer area as is.

It is recommended to set up some method for checking that the data is transferred correctly. This can for instance be achieved by including the data length and data type code in the application data of the message, so that the number of bytes and data type of application data can be identified on the receiving side.

17.2 Troubleshooting Flow

Following is a simple troubleshooting flowchart for when exchange cannot be conducted between the QE71 and the remote node. (*1)

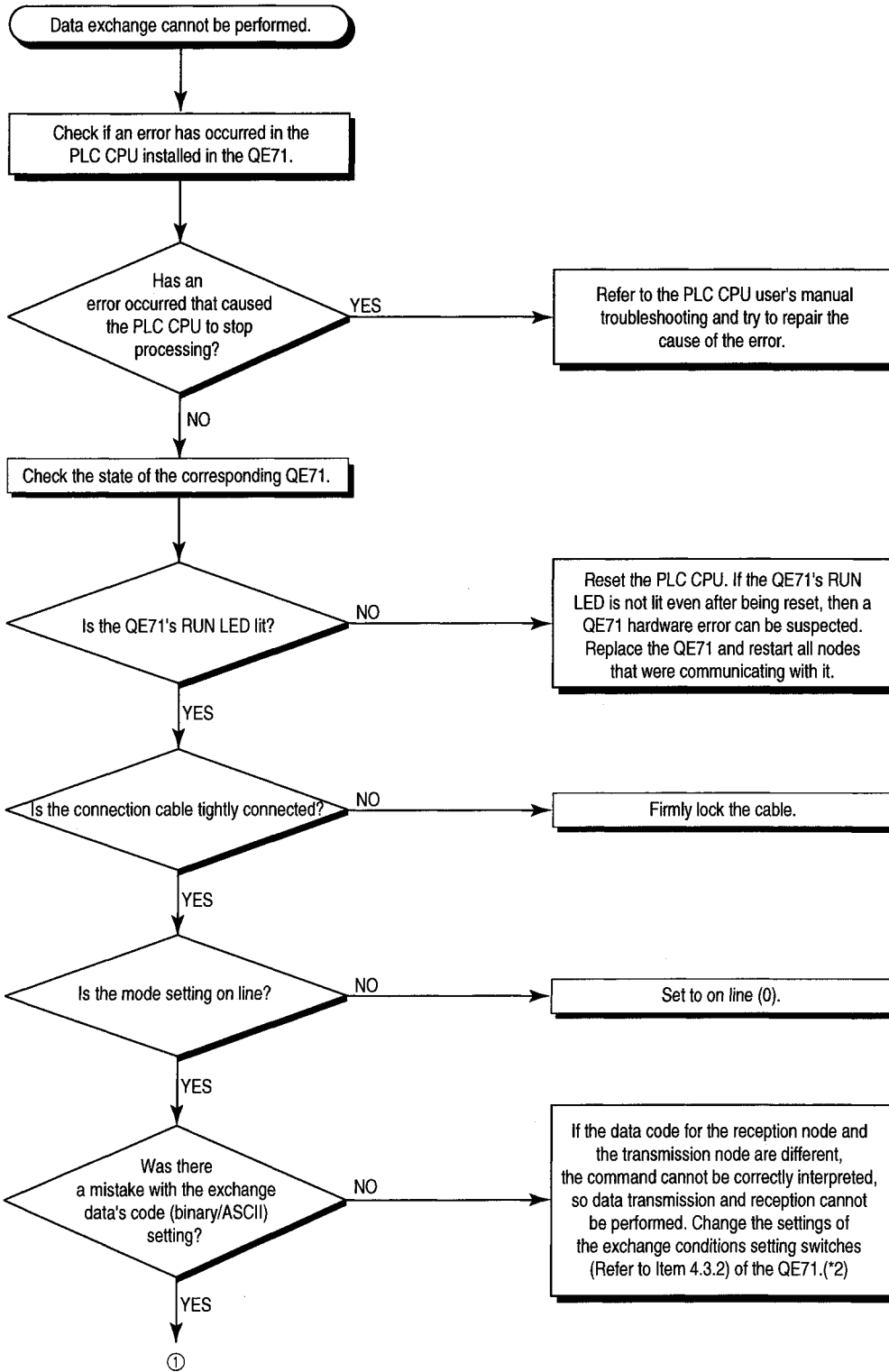

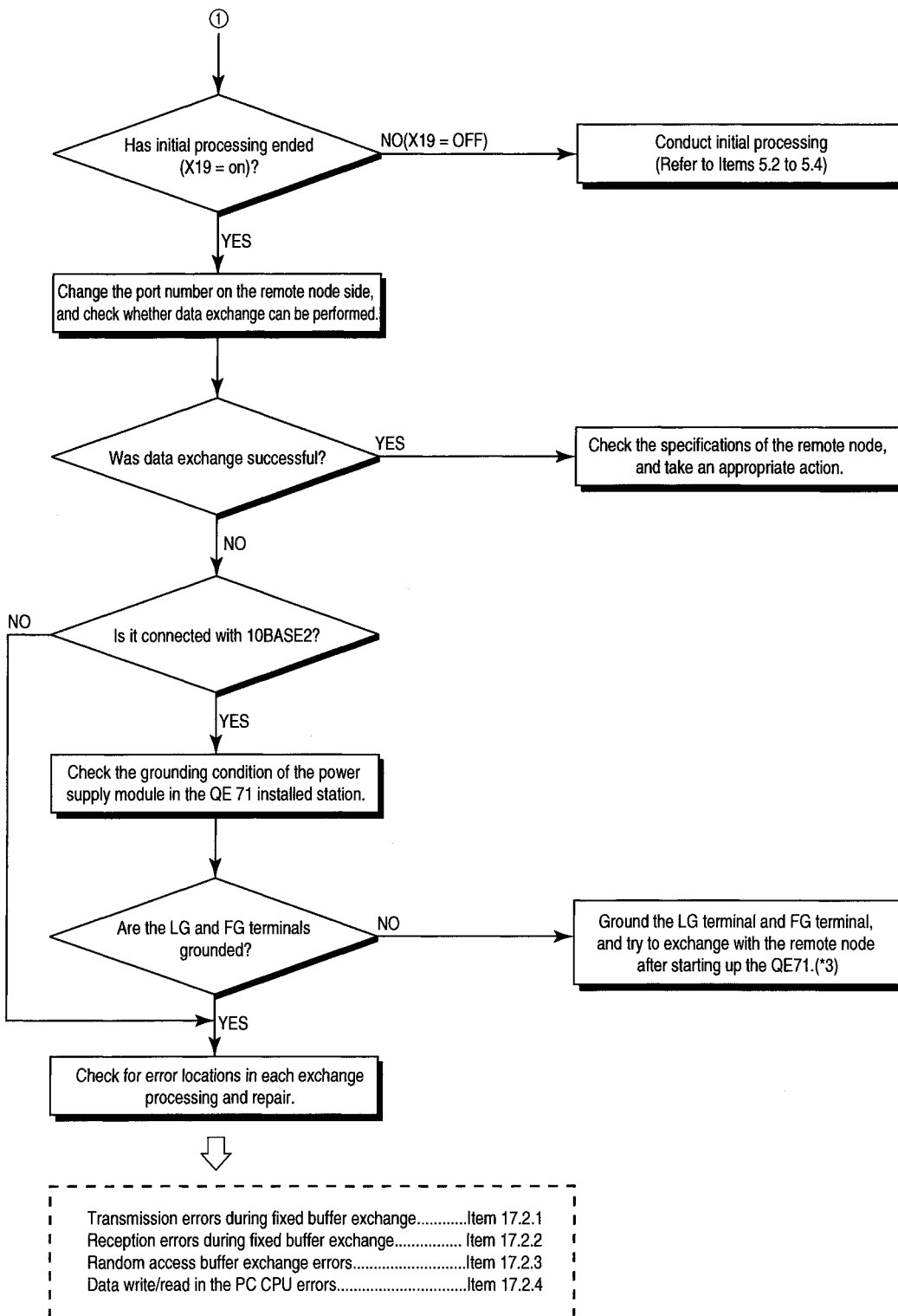

- *1 About turning on both the X1C of the input/output signal and display LED's COM. ERR
 - (1) The QE71 performs the following processing when an error such as a communication error is detected.
 - Stores an error code in one of the following buffer memory areas (an area that corresponds to the detected error).
 - Turns on the X1C of the input/output signal (COM. ERR LED on signal).
 - Turns on the display LED's COM. ERR (communication error detection display).

Area name		Address (Hexadecimal (Decimal))	Remarks
Initial error code storage area		69H(105)	The addresses shown at left are for connection 1.
Open error code storage area		7CH (124)	
Fixed buffer transmission error code storage area		7DH (125)	
Connection end code/error log storage area		7EH (126)	
Error log area	Error code/end code	E5H (229)	The address shown at left is for error log block 1.

(2) When the X1C of the input/output signal is on and the display LED's COM. ERR is on, check an error code stored in one of the above buffer memory areas, verify the error content according to the description in Section 17.1.3, and take an appropriate corrective action.

(3) The Y17 of the input/output signals (COM. ERR LED off request signal) is used to turn off the X1C of the input/output signal and display LED's COM. ERR. (See (15) in Item 3.6.2.)

After completing the following operation, turn off the X1C of the input/output signal and display LED's COM. ERR.

- Turn off all input signals (X18 open error detection signal, X1 transmission error detection signal, etc.) that are currently on by error detection.
- Check the error code and error content.

* Although it depends on the system specifications, it is recommended to turn off the X1C of the input/output signal and display LED's COM. ERR after a corrective action has been taken for the error.

*2 If the communication data code setting of the QE71 (see Section 4.3.2) and the data code setting of a remote node are different, an error code not listed in the error code list may be returned to the remote node side.

If the QE71 receives data with a different data code, it cannot decode the command correctly. The QE71 will return an error response according to the communication data code setting.

[Example] When communication is performed using a fixed buffer

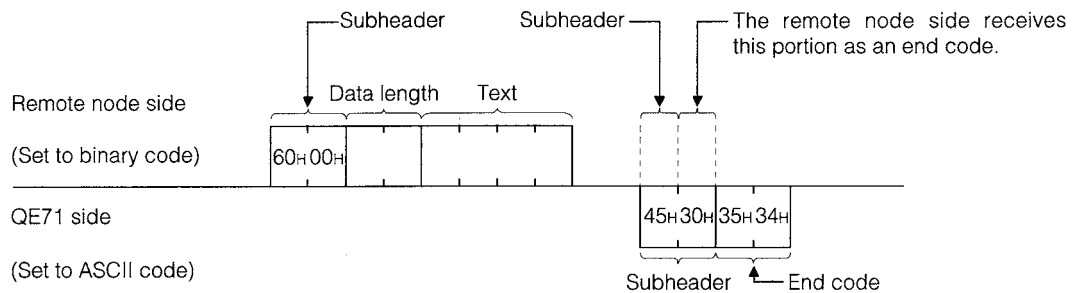

- *3 Be sure to ground the FG terminal and LG terminal of the power supply module in the QE71 installed station. If it is not grounded correctly, you can not exchange with the remote node because the influence of noise close (disconnect) the communication line.

Read carefully the PLC CPU User's Manual that describes the procedure for the installation or wiring work. And then, turn off the QE71 installed station power supply in order to reset the grounding of the LG terminal and FG terminal.

Point

- (1) If the QE71 has been replaced due to the occurrence of an abnormality, or the communication board/module on the remote node side that was performing data exchange with the QE71 has been replaced, restart the related devices and resume data communication by referring to Point in Section 4.11.
- (2) Verify the required devices and connection method by referring to the following when connecting the QE71 to Ethernet.
Item 2.3: Verifying the Required Devices
Item 4.7: Verifying the Connection Method
- (3) If a message sent from the remote mode cannot be received on the QE71 side on a frequent basis, check the values stored in the following buffer memory:

- Error code/end code storage area for each error log block in the error log storage area (address: E5H ···)

If the error detection count is high or the error code C0C7H has been stored, it might be caused by a high load on the Ethernet line due to data sending/receiving among devices connected. Then, it is necessary to take measures such as separating the network or reducing the data sending count in order to reduce the load on the Ethernet line. Take necessary measures to reduce the load on the Ethernet line after consulting with the network manager.

17.2.1 Transmission Error During Fixed Buffer Exchange (With Procedure/ Without Procedure Commonization)

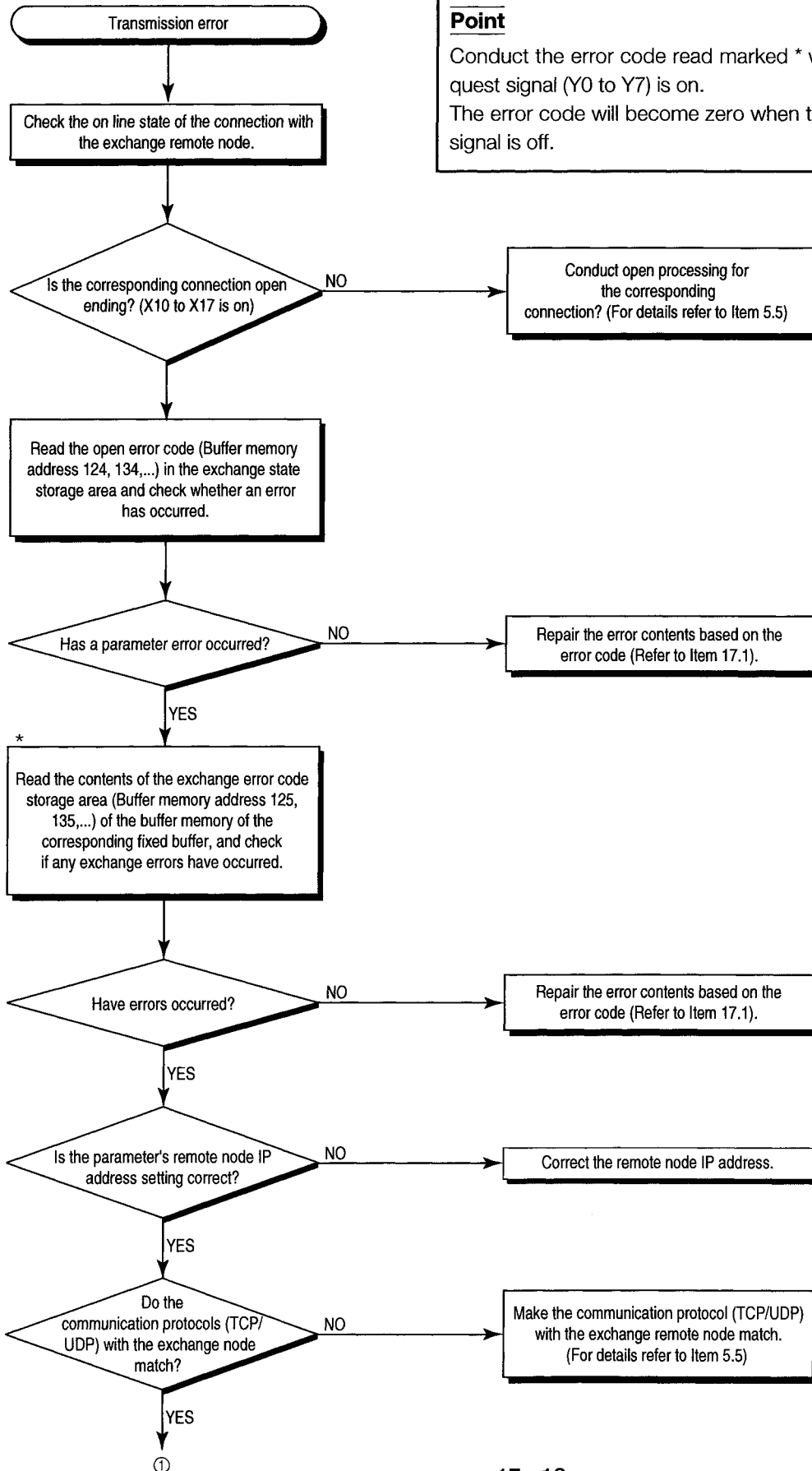

Point
 Conduct the error code read marked * when the transmission request signal (Y0 to Y7) is on.
 The error code will become zero when the transmission reception signal is off.

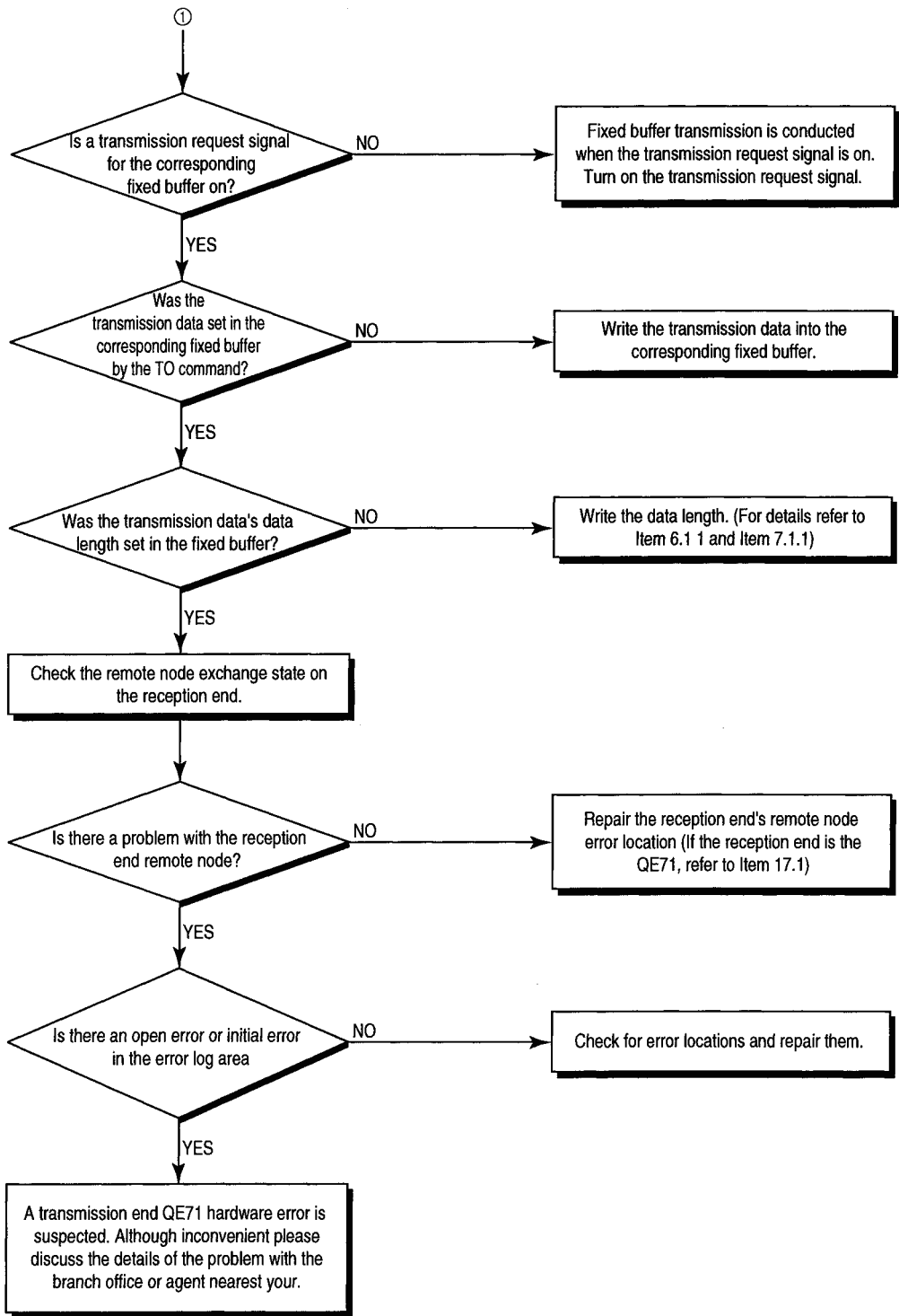

17.2.2 Reception Errors During Fixed Buffer Exchange (With Procedure/ Without Procedure Commonization)

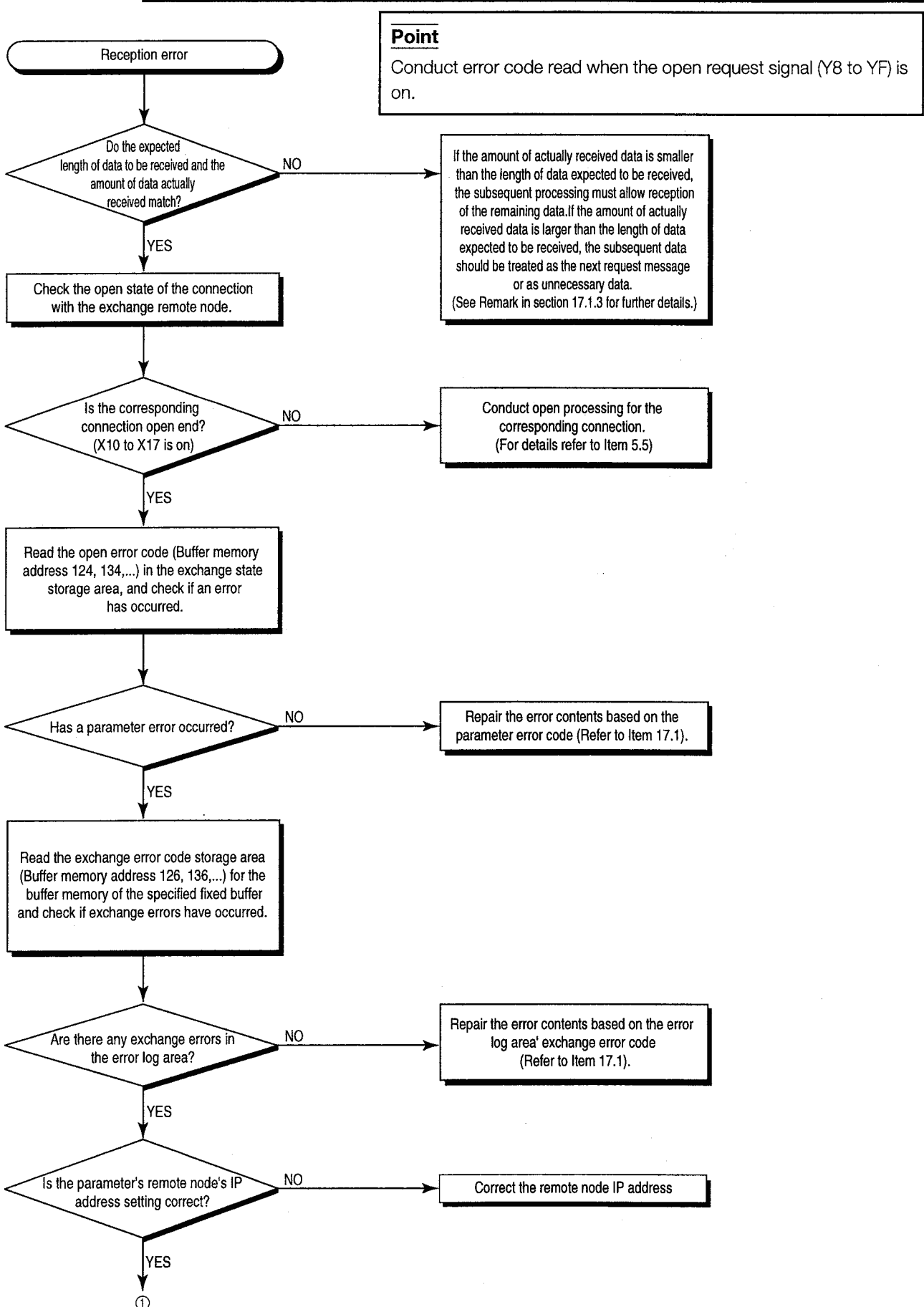

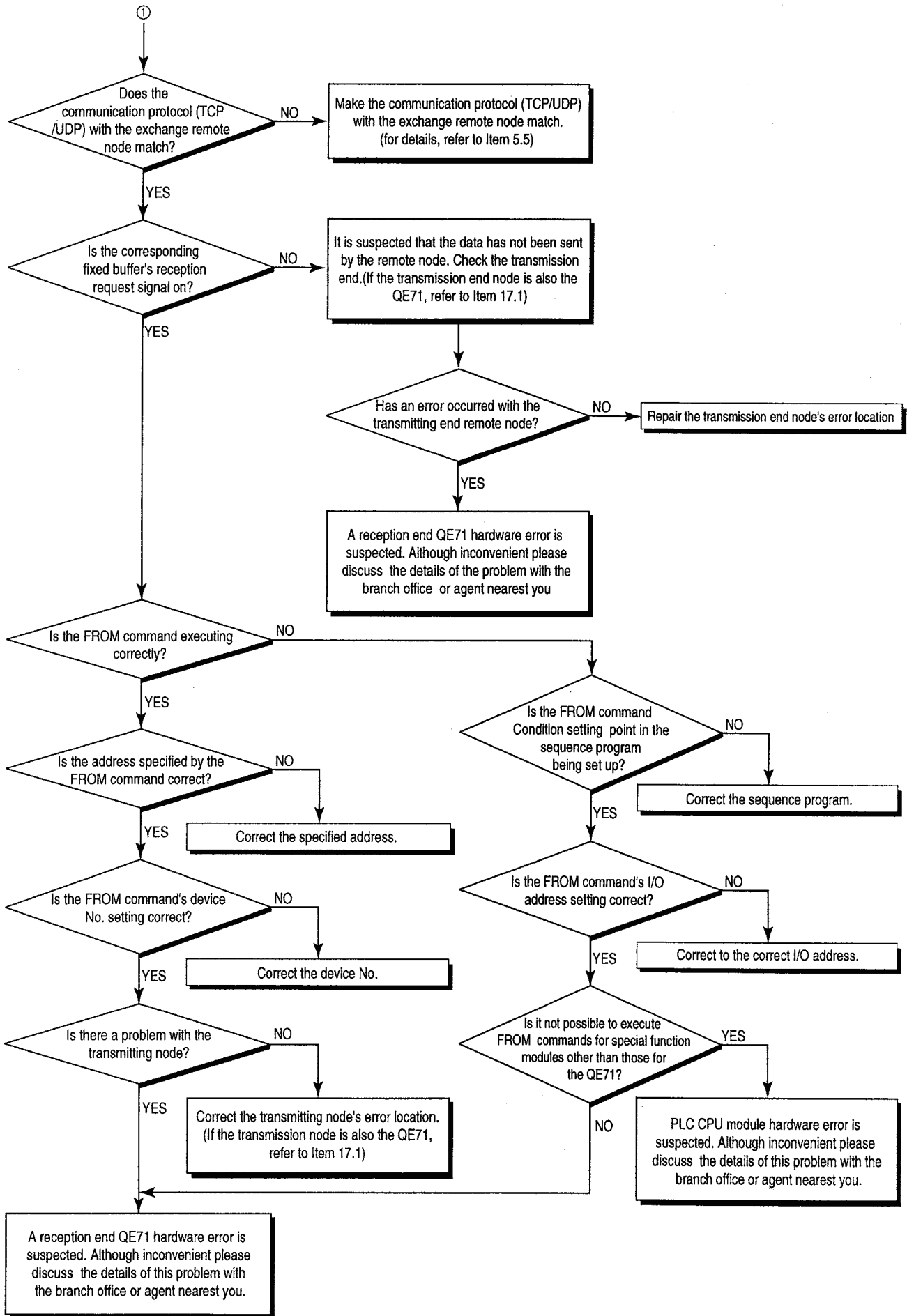

17.2.3 Errors During Random Access Buffer Exchange

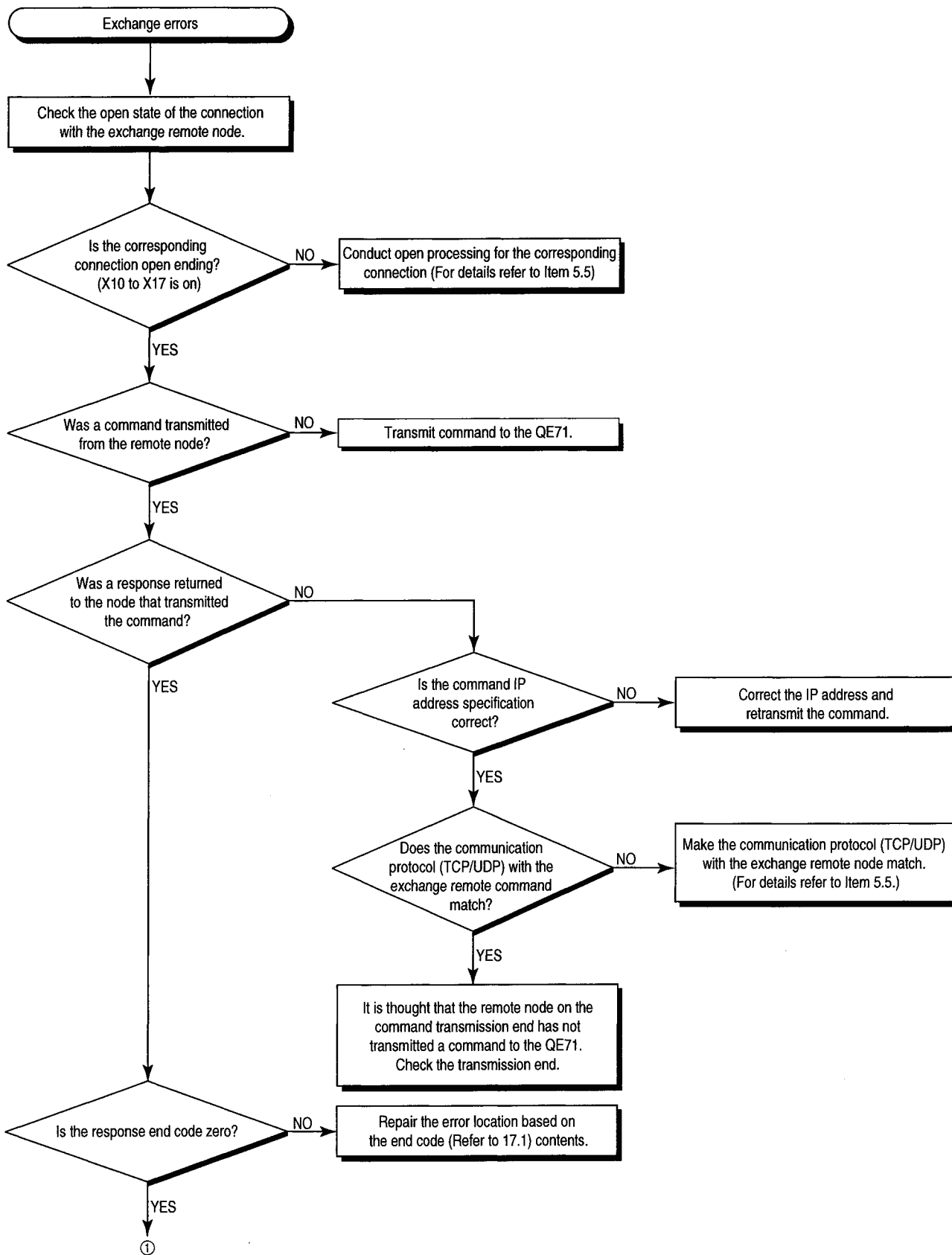

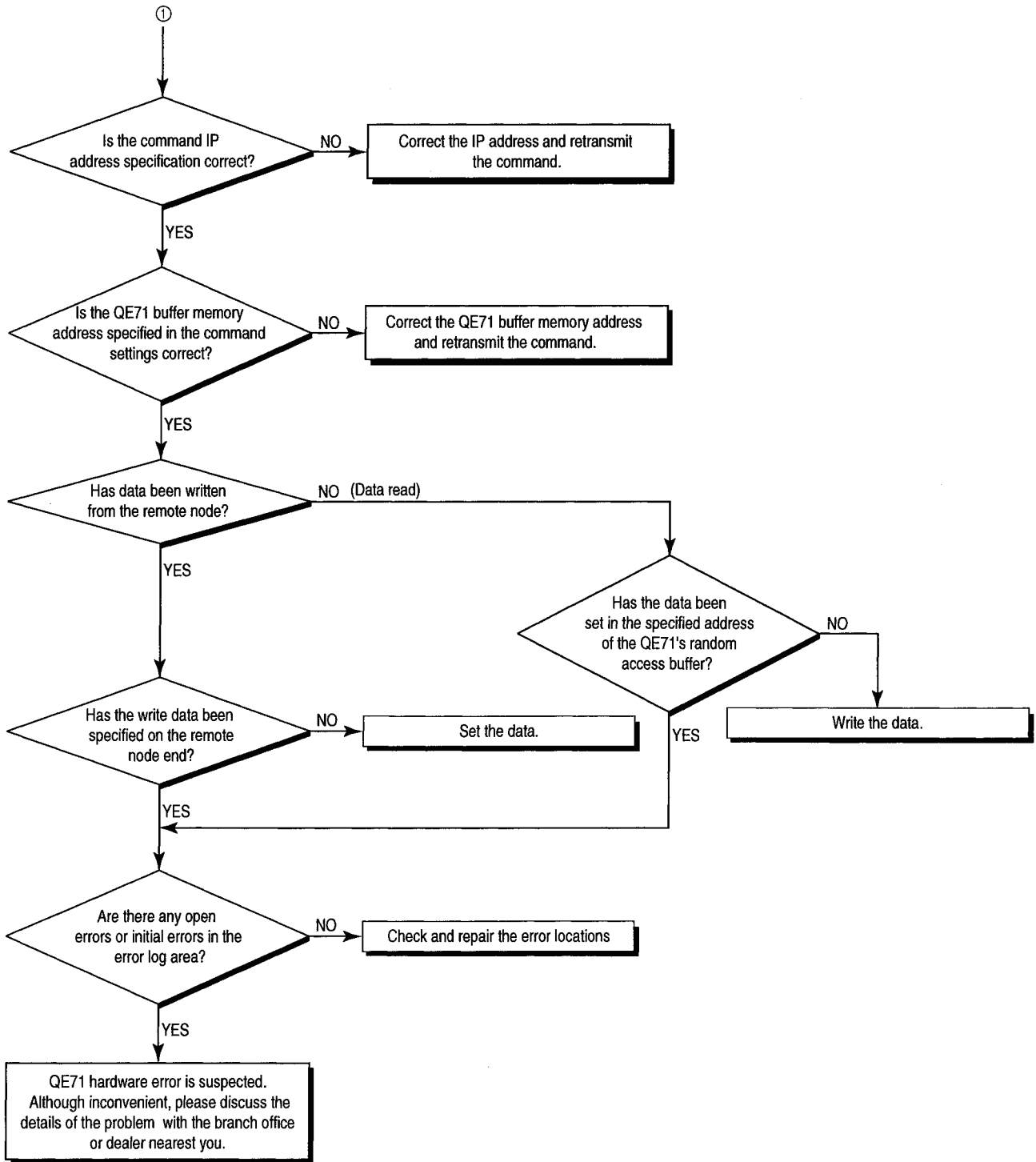

17.2.4 Errors When Reading/Writing Data in the PLC CPU

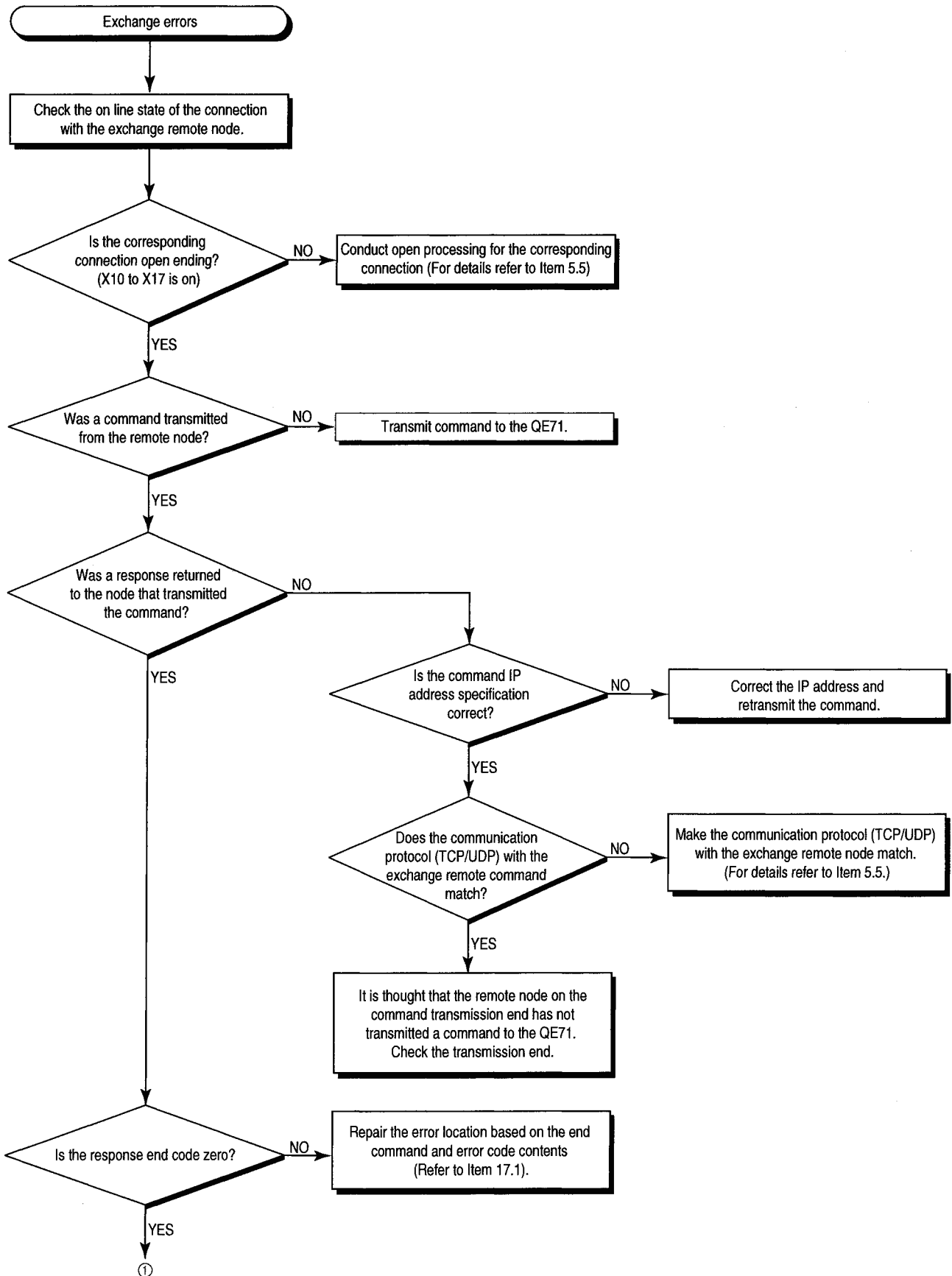

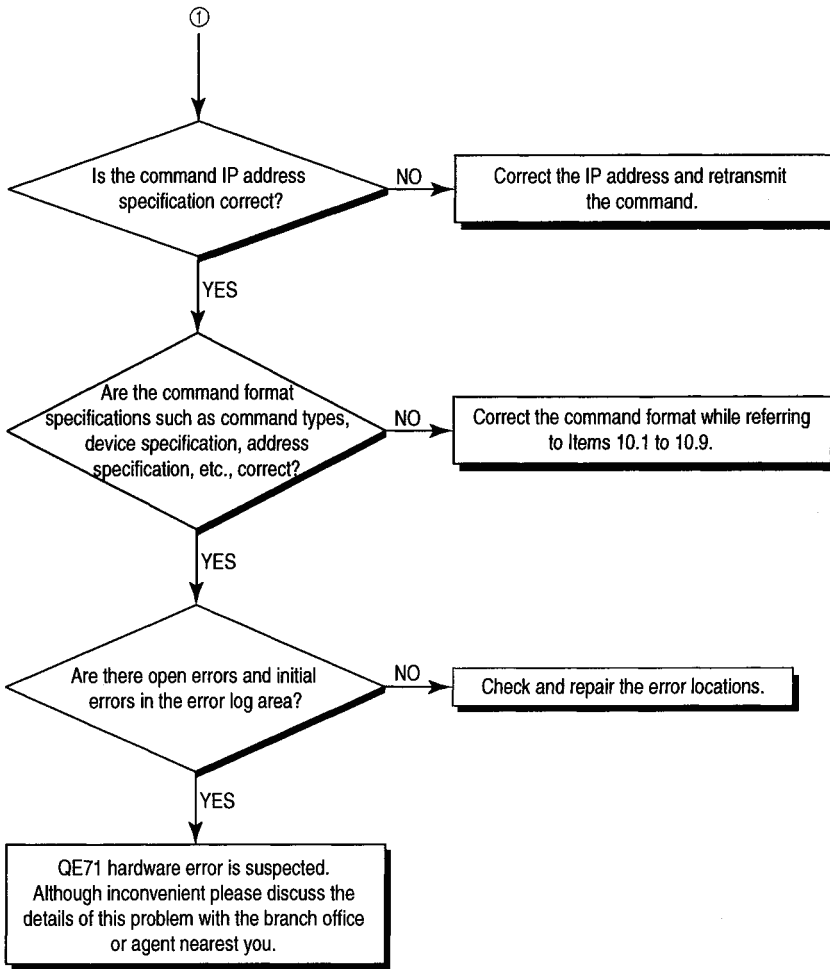

17.3 Checking the Existence of Errors on the PLC Side and the Contents of Errors

This section explains how to check whether errors, which may occur during data exchange between the QE71 and remote nodes, exist on the QE71 side and the contents of errors.

1

Countermeasures for errors

If an error occur, be sure to obtain the following details for each device as much as possible:

- ① Type of the trouble occurred
- ② The current phenomenon and the contents of the error that is occurring on the QE71 side and the data exchange partner device side.
- ③ Which node side is causing the problem?
- ④ What made the trouble to occur (also check the contents of data exchange at the error occurrence)?
- ⑤ Did any installation environment change before and after the occurrence of the trouble (such as noise)?
- ⑥ Did any system configuration change before and after the occurrence of the trouble (such as system expansion)?
- ⑦ Check to see if the situation will improve by replacing the QE71/remote node, if such replacement is possible.
- ⑧ Is the QE71 side normal?
 - Check whether hardware is normal. (Check with the self diagnostic test by referring to Item 4.6.)
 - Check whether initial processing has normally been completed. (Check with the RDY LED (flashing) and the input signal X19 (ON) by referring to Items 4.4, 5.3, and 5.4.)
 - Check whether the connection between the remote node with which data exchange is being performed is open. (Check with the BUF_n LED (lit) and the input signals X10 to X17 (ON) by referring to Items 4.4 and 5.5.)

2

How to check the existence of errors on the QE71 side and the contents of errors

The following methods are used to check whether there is an error on the QE71 side and the contents of the error. Using one of the following methods, check whether an error exists, its content if there is any error, and then take an appropriate corrective action.

(a) Checking via the LED indicator on the QE71

Whether there is an error on the QE71 side can be checked by the on/off status of the LED indicator on the QE71. (See Item 4.4 and *1 in Item 17.2.)

(b) Checking via GPPW

Using GPPW, various states on the QE71 side and the error code corresponding to the contents of the error currently occurring can be checked. It can also perform tests.

- ① Ethernet diagnostics (using a dedicated screen)
 - Various setting status monitoring (see Item 17.4.1)
 - PING test (see Item 5.3.3)
 - COM.ERR off (see Item 3.6.2 **15**.)

② Buffer memory batch monitoring

Error codes can be checked by monitoring the buffer memory of the QE71.

- Exchange state storage area (see Item 5.6.1)
- Error log area (see Item 5.6.2)

(c) Checking the contents of the error from the error code (see Item 17.1)

In order to take a corrective action, the contents of an error can be checked from the error code displayed on the above dedicated screen or via buffer memory monitoring as well as by referring to Item 17.1.

Remarks

If line errors and other errors occur, the user needs to isolate the malfunctioning sections using a line analyzer, etc.

17.4 How to Check an Error Through GPPW

The status of the various settings for the QE71 can be checked using the GPPW (GX Developer version 6 or later).

1 Ethernet diagnostics (See Item 17.4.1.)

The status of a QE71, parameter settings, exchange status, error log and others can be checked using the Ethernet diagnostic function.

The following are the functions of the Ethernet diagnostics.

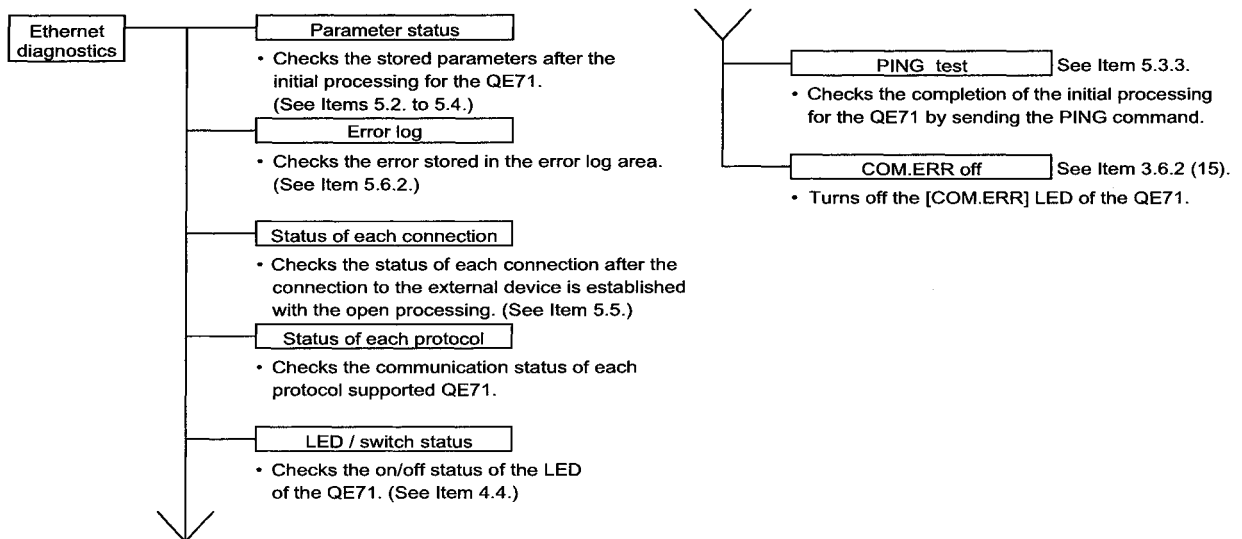

2 Buffer memory batch monitor (See Item 17.4.3.)

The buffer memory of an Ethernet module is monitored.

Point

- (1) See Item 17.4.2 for the buffer memory that can be checked on the "Ethernet diagnostics" screen.
- (2) The "Ethernet diagnostics" can be performed to the QnACPU function version B (the Q4ARCPU is a function added product).

17.4.1 Ethernet Diagnostics

[Purpose]

The status of the QE71, parameter settings, communication status, error log and other items can be checked using the Ethernet diagnostic function of GPPW.

[Operating procedure]

GPPW → [Diagnostics] → Ethernet diagnostics

[Ethernet diagnostics screen]

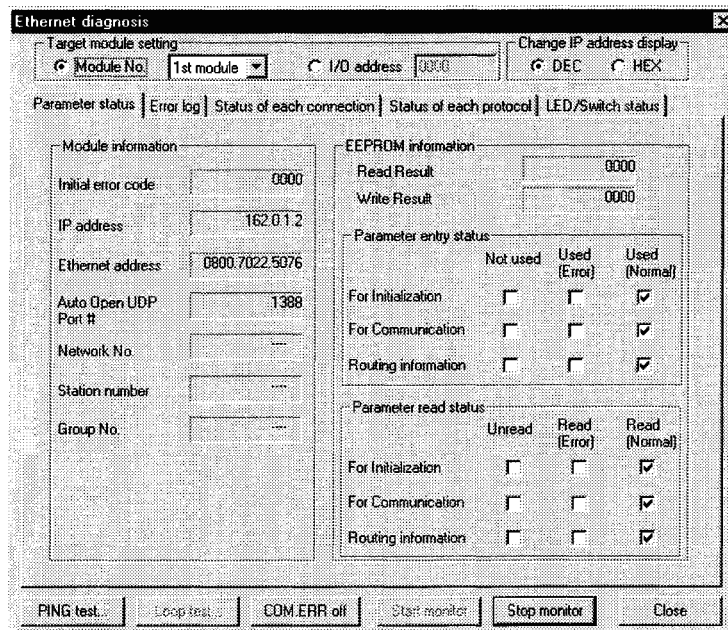

Remarks

For more information on how to operate the Ethernet diagnostics screen, refer to the operating manual of GPPW being used.

17.4.2 Buffer Memory that can be Monitored with the GPPW Diagnostic Function

The following lists the buffer memory addresses that can be displayed on the "Ethernet diagnostics" screen of GPPW. The display screen and display contents of the Ethernet diagnostics screen are shown.

Ethernet diagnostics display screen	Display contents		Applicable buffer memory		
			Address Decimal (Hexadecimal)	Name	
Status of each connection	Connection No. 1	Existence confirmation	32 (20H)	Connectio No. 1	Sets intended use
		Pairing open			
Protocol					
Open system					
	Connection Nos. 2 to 8 (same as connection No. 1)		33 to 39 (21H to 27H)	Connection No. 2 to 8 (same as connection No. 1)	
Parameter status	Module information	Initial error code	105 (69H)	Initial error code	
		IP address	106 to 107 (6AH to 6BH)	IP address of the local station's QE71	
		Ethernet address	108 to 110 (6CH to 6EH)	Ethernet address of the local station's QE71	
	Parameter entry status	Parameter entry status	112 (70H)	EEPROM registration status	
	Parameter read status	Parameter read status	113 (71H)	Parameter usage status	

(Continues on the next page)

(Continued from the previous page)

Ethernet diagnostics display screen	Display contents		Applicable buffer memory	
			Address Decimal (Hexadecimal)	Name
Parameter status	EEPROM information	Read result	114 (72H)	EEPROM read result
		Write result	115 (73H)	EEPROM write result
	Module information	Auto open UDP port No.	116 (74H)	Auto open UDP port No.
		Network No. Station No.	118 (76H)	Network No., station No.
		Group No.	119 (77H)	Group No.
Status of each connection	Connection No. 1	Local station port No.	120 (78H)	Connection No. 1 Information for each connection
		Exchange partner's IP address	121 to 122 (79H to 7AH)	
		Destination port No.	123 (7BH)	
		Open error code	124 (7CH)	
		Fixed buffer transfer error code	125 (7DH)	
		Connection end code	126 (7EH)	
	Connection Nos. 2 to 8 (same as connection No. 1)	130 to 196 (82H to C4H)	Connection Nos. 2 to 8 (same as connection No. 1)	
LED / Switch status	LED display status	RDY to TEST.ERR	200 (C8H)	LED on/off status (left side)
		B1 to B8	201 (C9H)	LED on/off status (right side)
	Drive mode	202 (CAH)	Setting status of the operation mode setting switch	
	Switch status	SW1 to SW8	203 (CBH)	Setting status of the exchange condition setting switch
Error log	Latest	Number of error occurrences	227 (E3H)	Error log block 1 Number of error occurrences Error code/end code Subheader Command code Connection No. Local station's QE71 port number Remote node's IP address Remote node's port No.
		Error end code	229 (E5H)	
		Sub header	230 (E6H)	
		Command code	231 (E7H)	
		Connection No.	232 (E8H)	
		Local station port No.	233 (E9H)	
		Destination IP address	234 to 235 (EAH to EBH)	
		Destination port No.	236 (ECH)	
	Nos. 2 to 16	238 to 372 (EEH to 174H)	Error log blocks 2 to 16 (same as error log block 1)	
	Status of each protocol	IP packet	Total number of receives	376 to 377 (178H to 179H)
Total number of sum check error annulments			378 to 379 (17AH to 17BH)	
Total number of sends			380 to 381 (17CH to 17DH)	
ICMP packet		Total number of receives	408 to 409 (198H to 199H)	
		Total number of sum check error annulments	410 to 411 (19AH to 19BH)	
		Total number of sends	412 to 413 (19CH to 19DH)	
		Total number of echo request receive	414 to 415 (19EH to 19FH)	
		Total number of echo reply sends	416 to 417 (1A0H to 1A1H)	
		Total number of echo request sends	418 to 419 (1A2H to 1A3H)	
		Total number of echo reply receives	420 to 421 (1A4H to 1A5H)	
TCP packet		Total number of receives	440 to 441 (1B8H to 1B9H)	
		Total number of sum check error annulments	442 to 443 (1BAH to 1BBH)	
		Total number of sends	444 to 445 (1BCH to 1BDH)	
UDP packet		Total number of receives	472 to 473 (1D8H to 1D9H)	
		Total number of sum check annulments	474 to 475 (1DAH to 1DBH)	
		Total number of sends	476 to 477 (1DCH to 1DDH)	

17.4.3 Checking the Error Information by the Buffer Memory Batch Monitoring Function

It is explained how the error codes stored in the buffer memory of the QE71 can be monitored using the "Buffer memory batch monitoring" function of GPPW.

[Operating procedure]

(Step 1) Select [Online] - [Monitor] - [Buffer memory batch] from the GPPW, and start the "Buffer memory batch monitoring" screen.

(Step 2) Enter [Module start address:].

For the module start address, enter the start I/O number of the QE71 to be monitored as four digits.

(Example)

Start I/O signal: Enter "0020" when monitoring modules of X/Y0020 to 003F

(Step 3) Enter [Buffer memory start address:].

Enter the buffer memory address to be monitored, using the selected input format (decimal/hexadecimal).

For a list of the buffer memory addresses where error codes are stored, see Section 17.1.3, "Error Code List".

(Example)

When monitoring the initial abnormal code (buffer memory storage address: 69H):

Enter "69" + "hexadecimal"

(Step 4) Click the button.

The contents of the buffer memory after the specified address are displayed. (In case of the above example, the contents of 69H and succeeding addresses are displayed.)

The display format can be modified as follows:

Monitor format : Bits & words/ Multiple bit points/ Multiple word points

Display : 16-bit integer/32-bit integer/real number/ASCII character

Numerical value : Decimal/hexadecimal

For details, refer to the "Operating Manual" for GPPW.

APPENDICES

Appendix 1 Using the Existing Program and Replacing Module

The data exchange between the PLC CPU and remote nodes on the Ethernet, performed by the existing program's A/QnA series Ethernet interface module (such as AJ71E71 or AJ71QE71), can also be performed using the QE71.

The following describes how to use the existing programs to perform data exchange using the QE71 and replace the module.

- * The response speed of the QE71 is different from the response speeds of the conventional A/QnA Series Ethernet interface modules. (For the processing time, see Appendix 3.)
Therefore, if any of the conventional A/QnA Series Ethernet interface modules is replaced with a QE71 and the programs for the conventional modules are used for the QE71, be sure to check the operation of the QE71, and adjust the exchange time interval and retry count as needed.

1 Using the AJ71E71 (-S3) program

- (a) Using the program on the remote node side

The program for the following exchange function area on the remote node side with the AJ71E71 (-S3) (abbreviated as E71 from here on) can be used for the exchange with the QE71.

(Exchange Possible Function Using the Program Diversion)

The remote node in the table is the node that is conducting data exchange to the E71.

Exchange partner Program for E71		Remote node to QE71	QE71 to Remote node	E71 to QE71	QE71 to E71
		Exchange functions	Fixed buffer exchange (With procedure)	○	○
	Random access buffer exchange	○	/	/	/
	Reading/writing data in the PLC CPU (*1)	○	/	/	/

○ : Exchange is possible by diverting as is the program for the E71 from the remote node

- *1 The commands that can be used for data exchange are only the E71 commands shown in Item 9.2.2.

Conduct data exchange while checking the access possible range using Item 9.1. When exchanging data using functions other than those shown in Item 9.2.2, create a new program in accordance with the instructions in Chapter 10.

- (b) Using the local station E71 sequence program

Because the buffer memory allocations are different for the QE71 and E71, the E71 sequence program cannot be used for the QE71.

Refer to the chapter which describes each function, and create a new sequence program.

2 Using the AJ71QE71 program

- (a) Using the program on the remote node side

The program on remote node side for the AJ71QE71 can be used for the exchange with the QE71.

- (b) Using the local station AJ71QE71 sequence program

The sequence program for the local station AJ71QE71 can be used for the exchange for the QE71.

3 Module compatibility

The following explains the module compatibility when any of the conventional QnA corresponding Ethernet interface modules (such as the AJ71QE71, which will be abbreviated as the QE71 (conventional product) hereafter) is replaced with the QE71 described in this manual.

- (a) The QE71 is equivalent to a function version B product of the QE71 (conventional product, discontinued product).

The hardware specifications for performing data exchange are the same between the QE71 and the QE71 (conventional product, discontinued product). (They are compatible.)

The following table indicates the interfaces and 5VDC internal current consumption values of the QE71 and QE71 (conventional product, discontinued product) :

	Model name	Interface			5VDC internal current consumption value
		10BASE2	10BASE5	10BASE-T	
QE71 (conventional product, discontinued product)	AJ71QE71	○	○	×	0.80A
	AJ71QE71-B5	×	○	×	0.80A
	AJ71QE71N-B5T *1	×	○	○	0.48A
	AJ71QE71N-T	×	×	○	0.40A
	A1SJ71QE71-B2	○	×	×	0.80A
	A1SJ71QE71-B5	×	○	×	0.60A
	A1SJ71QE71N-B5T *2	×	○	○	0.42A
	A1SJ71QE71N-T	×	×	○	0.40A
QE71	AJ71QE71N-B2	○	×	×	0.56A
	AJ71QE71N-B5	×	○	×	0.40A
	AJ71QE71N3-T	×	×	○	0.53A
	A1SJ71QE71N-B2	○	×	×	0.53A
	A1SJ71QE71N-B5	×	○	×	0.40A
	A1SJ71QE71N3-T	×	×	○	0.53A

*1 The hardware specifications are the same as those of the AJ71QE71N-T and AJ71QE71N-B5. (There is compatibility.)

The 10BASE-T and 10BASE5 interfaces cannot be used together.

*2 The hardware specifications are the same as those of the A1SJ71QE71N-T and A1SJ71QE71N-B5. (There is compatibility.)

The 10BASE-T and 10BASE5 interfaces cannot be used together.

- (b) Precautions for replacing the QE71 (conventional product, discontinued product) by the QE71
- When replacing an old QE71 by a new QE71, make sure that the power supply module has a sufficient current-carrying capacity.

If the power supply module does not have a sufficient current-carrying capacity, replace it with a power supply module that can supply a necessary current.

(c) The following illustrates the differences between of the QE71 and the QE71 (conventional products).

[QE71 (conventional products)]

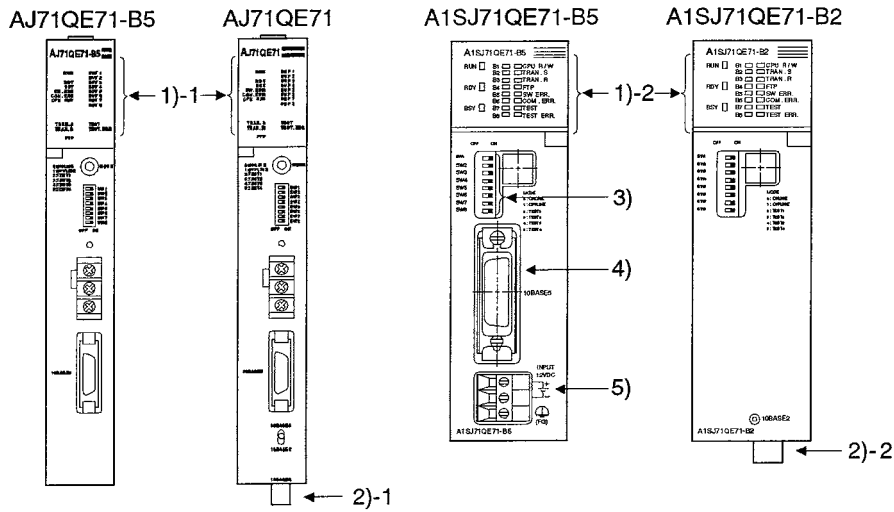

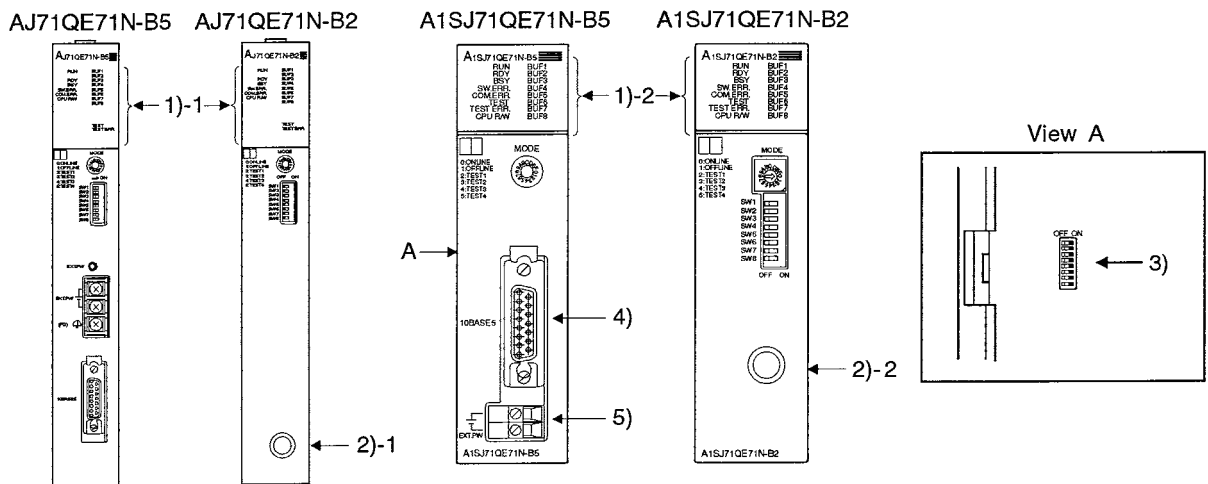

[QE71]

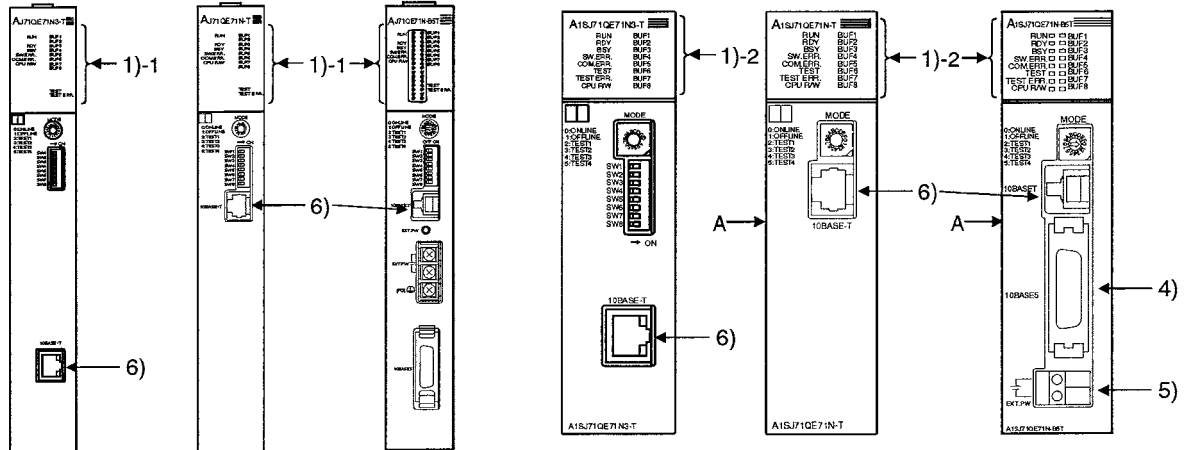

AJ71QE71N3-T AJ71QE71N-T AJ71QE71N-B5T A1S71QE71N3-T A1S71QE71N-T A1S71QE71N-B5T

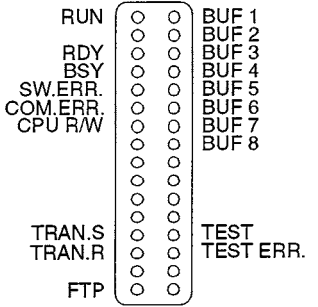
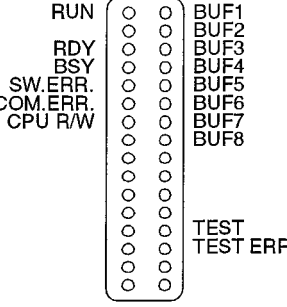
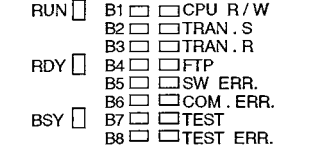
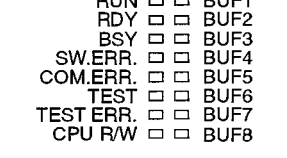
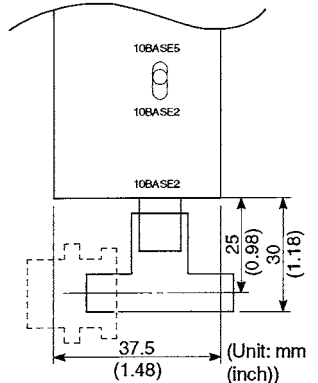
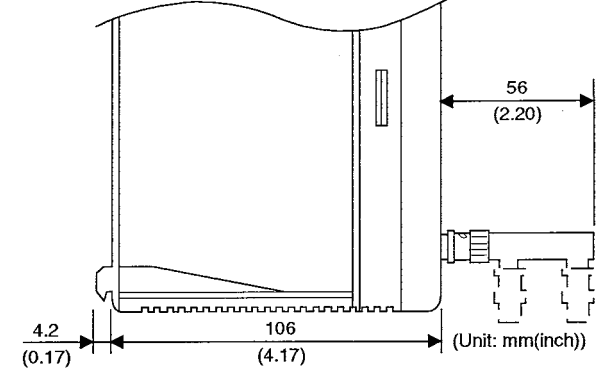
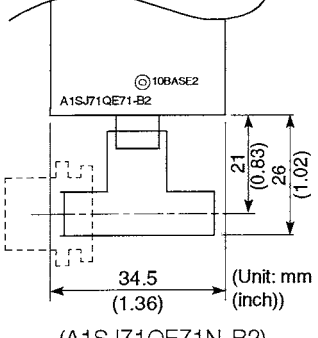
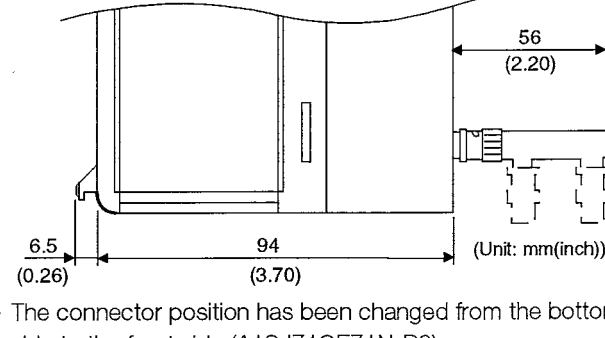

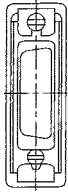
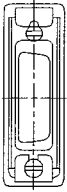
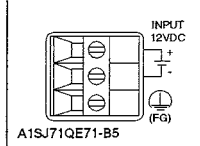
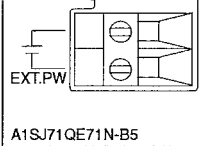
No. in drawing	Item	QE71 (conventional products)	QE71
①-1	LED displays (Refer to Item 4.4)	 <p>(AJ71QE71, AJ71QE71-B5)</p>	 <p>(AJ71QE71N3-T, AJ71QE71N-T, AJ71QE71N-B5, AJ71QE71N-B2, AJ71QE71N-B5T)</p> <ul style="list-style-type: none"> There are no more TRAN.S, TRAN.R and FTP LED displays. To check the information of TRAN.S, TRAN.R and FTP, read the LED lighting status storage area (address C8H) of buffer memory. (Refer to Item 5.6.1 (17).)
①-2		 <p>(A1SJ71QE71-B5, A1SJ71QE71-B2)</p>	 <p>(A1SJ71QE71N3-T, A1SJ71QE71N-T, A1SJ71QE71N-B5, A1SJ71QE71N-B2, A1SJ71QE71N-B5T)</p> <ul style="list-style-type: none"> The arrangement of LED displays has been changed. Notation of B1 through B8 has been changed to BUF1 to BUF8. There are no more TRAN.S, TRAN.R and FTP LED displays. To check the information of TRAN.S, TRAN.R and FTP, read the LED lighting status storage area (address C8H) of buffer memory. (Refer to Item 5.6.1 (17).)
②-1	10BASE2 interface connector position (Refer to Appendix 6)	 <p>(AJ71QE71)</p>	 <ul style="list-style-type: none"> The connector position has been changed from the bottom side to the front side (AJ71QE71N-B2).
②-2		 <p>(A1SJ71QE71N-B2)</p>	 <ul style="list-style-type: none"> The connector position has been changed from the bottom side to the front side (A1SJ71QE71N-B2).
③	Communication condition setting switch (Refer to Item 4.3.2)	<p>(A1SJ71QE71-B5)</p>	<ul style="list-style-type: none"> The location of the communication condition setting switch has been changed from the front side to the left side (A1SJ71QE71N-T, A1SJ71QE71N-B5, A1SJ71QE71N-B5T).

No. in drawing	Item	QE71 (conventional products)	QE71
④	10BASE5 interface connector orientation (Refer to Appendix 6)	 <p>(A1SJ71QE71-B5)</p>	 <ul style="list-style-type: none"> The orientation of the connector has been rotated by 180°. (A1SJ71QE71N-B5, A1SJ71QE71N-B5T).
⑤	External power supply terminal (Refer to Item 4.7.2)	 <p>(A1SJ71QE71-B5)</p>	 <ul style="list-style-type: none"> The FG terminal has been removed from the external power supply terminal (transceiver power supply connection terminal). If the external power supply side of the power supply source for the transceiver handles the FG signal, ground the FG signal on the external power supply side. <p>(A1SJ71QE71N-B5, A1SJ71QE71N-B5T)</p>
⑥	10BASE-T interface connector orientation (Refer to Appendix 6)	 <p>(AJ71QE71N-T, AJ71QE71N-B5T, A1SJ71QE71N-T, A1SJ71QE71N-B5T)</p>	 <ul style="list-style-type: none"> The orientation of the connector has been rotated by 180°. <p>(AJ71QE71N3-T, A1SJ71QE71N3-T)</p>

Appendix 2 Adding the QE71 to the Existing System

A QE71 and a conventional Ethernet interface module (E71S3, AJ71QE71, etc.) can coexist within the same Ethernet. The wiring used for the conventional Ethernet interface module can still be used to integrate the QE71 into the existing system's Ethernet.

Appendix 3 Processing Time

Use the following formulas to calculate the minimum transmission delay time for each function.

However, the transmission delay time is sometimes increased by the network load rate (line connections), each node window size, the number of connections used at the same time, and the system configuration. The value found using the following formula is used as the transmission delay time measure when conducting exchange while using one connection.

1 Fixed buffer exchange minimum transmission delay time (When exchanging between QE71 and QE71)

(a) For TCP/IP

$$\left(\begin{array}{l} \text{When communicating} \\ \text{in binary code} \end{array} \right) 21 + (0.012 \times \frac{\text{Command data length}}{\text{The unit is 1 byte}}) + (0.012 \times \frac{\text{Response data length}}{\text{The unit is 1 byte}}) + (\text{Transmission scan time}) + (\text{Reception scan time}) \text{ (ms)}$$

$$\left(\begin{array}{l} \text{When communicating} \\ \text{in ASCII code} \end{array} \right) 21 + (0.017 \times \frac{\text{Command data length}}{\text{The unit is 1 byte}}) + (0.017 \times \frac{\text{Response data length}}{\text{The unit is 1 byte}}) + (\text{Transmission scan time}) + (\text{Reception scan time}) \text{ (ms)}$$

(b) For UDP/IP

$$\left(\begin{array}{l} \text{When communicating} \\ \text{in binary code} \end{array} \right) 18 + (0.012 \times \frac{\text{Command data length}}{\text{The unit is 1 byte}}) + (0.012 \times \frac{\text{Response data length}}{\text{The unit is 1 byte}}) + (\text{Transmission scan time}) + (\text{Reception scan time}) \text{ (ms)}$$

$$\left(\begin{array}{l} \text{When communicating} \\ \text{in ASCII code} \end{array} \right) 18 + (0.017 \times \frac{\text{Command data length}}{\text{The unit is 1 byte}}) + (0.017 \times \frac{\text{Response data length}}{\text{The unit is 1 byte}}) + (\text{Transmission scan time}) + (\text{Reception scan time}) \text{ (ms)}$$

Command data length : This is the data length including the subheader, data length, and text data , that is set in the command application data portion for fixed buffer data transmission. The unit is 1 byte.

	Command data length	
	With procedure	Without procedure
Exchange using binary code	4 + (Data length) × 2	(Number of text bytes)
Exchange using ASCII code	8 + (Data length) × 4	—

Response data length : This is the data length that is fixed in the response application data portion and includes the subheader and end code when receiving data using the fixed buffer. The unit is 1 byte.

	Response data length	
	With procedure	Without procedure
Exchange using binary code	2	—
Exchange using ASCII code	4	—

[Example calculation]

The minimum transmission delay time when transmitting 1017 words of data between the QE71 and a QE71 when TCP/IP binary code exchange is used for the protocol.

(The transmission scan time is 10ms, and the reception scan time is 10ms.)

$$21 + (0.012 \times (4 + (1017 \times 2))) + (0.012 \times 2) + 10 + 10 \approx 65 \text{ (ms)}$$

2 Random access buffer exchange minimum transmission delay time

(a) For TCP/IP

$$\left(\begin{array}{l} \text{When communicating} \\ \text{in binary code} \end{array} \right) 6 + \underbrace{(0.005 \times (\text{Command data length}))}_{\text{The unit is 1 byte.}} + \underbrace{(0.002 \times (\text{Response data length}))}_{\text{The unit is 1 byte.}} + (\text{Remote node ACK processing time}) \text{ (ms)}$$

$$\left(\begin{array}{l} \text{When communicating} \\ \text{in ASCII code} \end{array} \right) 6 + \underbrace{(0.009 \times (\text{Command data length}))}_{\text{The unit is 1 byte.}} + \underbrace{(0.003 \times (\text{Response data length}))}_{\text{The unit is 1 byte.}} + (\text{Remote node ACK processing time}) \text{ (ms)}$$

(b) For UDP/IP

$$\left(\begin{array}{l} \text{When communicating} \\ \text{in binary code} \end{array} \right) 4 + \underbrace{(0.005 \times (\text{Command data length}))}_{\text{The unit is 1 byte.}} + \underbrace{(0.002 \times (\text{Response data length}))}_{\text{The unit is 1 byte.}} \text{ (ms)}$$

$$\left(\begin{array}{l} \text{When communicating} \\ \text{in ASCII code} \end{array} \right) 4 + \underbrace{(0.008 \times (\text{Command data length}))}_{\text{The unit is 1 byte.}} + \underbrace{(0.003 \times (\text{Response data length}))}_{\text{The unit is 1 byte.}} \text{ (ms)}$$

Command data length : This is the data length including the subheader, data length, text data, that is set in the command application data portion when reading and writing is conducted to and from the random access buffer. The unit is 1 byte.

	Command data length	
	Read	Write
Exchange using binary code	6	6 + ((Data length) × 2)
Exchange using ASCII code	12	12 + ((Data length) × 4)

Response data length : This is the data length including the subheader and end code, that is set in the response application data portion when reading from and writing to the random access buffer is conducted. The unit is 1 byte.

	Response data length	
	Read	Write
Exchange using binary code	2 + ((Data length) × 2)	2
Exchange using ASCII code	6 + ((Data length) × 4)	6

Remote node ACK processing : This is the time from when the read/write to or from the random access buffer ends until the remote node returns ACK.

[Example calculation 1]

The minimum transmission delay time when 508 words of data are read using the UDP/IP's ASCII code exchange as the protocol

$$4 + (0.008 \times 12) + (0.003 \times (6 + (508 \times 4))) \approx 10 \text{ (ms)}$$

[Example calculation 2]

The minimum transmission delay time when 508 words of data are written using the UDP/IP's ASCII code as the exchange protocol

$$4 + (0.008 \times (12 + (508 \times 4))) + (0.003 \times 6) \approx 20 \text{ (ms)}$$

3 Minimum transmission delay time when reading/writing (word units) in the PLC CPU

(a) For TCP/IP

$$\left(\begin{array}{l} \text{When communicating} \\ \text{in binary code} \end{array} \right) 18 + (0.020 \times \frac{\text{Command data length}}{\text{The unit is 1 byte}}) + (0.007 \times \frac{\text{Response data length}}{\text{The unit is 1 byte}}) \\ + (\text{PLC CPU processing time}) + (\text{Remote node ACK processing time}) \text{ (ms)}$$

$$\left(\begin{array}{l} \text{When communicating} \\ \text{in ASCII code} \end{array} \right) 20 + (0.036 \times \frac{\text{Command data length}}{\text{The unit is 1 byte}}) + (0.012 \times \frac{\text{Response data length}}{\text{The unit is 1 byte}}) \\ + (\text{PLC CPU processing time}) + (\text{Remote node ACK processing time}) \text{ (ms)}$$

(b) For UDP/IP

$$\left(\begin{array}{l} \text{When communicating} \\ \text{in binary code} \end{array} \right) 14 + (0.010 \times \frac{\text{Command data length}}{\text{The unit is 1 byte}}) + (0.006 \times \frac{\text{Response data length}}{\text{The unit is 1 byte}}) \text{ (ms)} \\ + (\text{PLC CPU processing time})$$

$$\left(\begin{array}{l} \text{When communicating} \\ \text{in ASCII code} \end{array} \right) 15 + (0.012 \times \frac{\text{Command data length}}{\text{The unit is 1 byte}}) + (0.006 \times \frac{\text{Response data length}}{\text{The unit is 1 byte}}) \text{ (ms)} \\ + (\text{PLC CPU processing time})$$

Command data length	: This is the data length including the subheader, data length, and text data, that is specified in the command application data portion when data is read from or written to the PLC CPU. The unit is 1 byte. The command data length changes depending on the commands used. Refer to Items 10.1 and 10.2 to 10.9.
Response data length	: This is the data length including the subheader and the end code that is set in the response application data portion when data is read from or written to the PLC CPU. The unit is 1 byte. The command data length changes depending on the commands used. Refer to the Item 10.1 and Items 10.2 to 10.9.
PLC CPU processing time	: This is the processing time of the request to read/write data to the PLC CPU. This time is determined by the read/write data, number of points to process, and the PLC CPU scan time. Refer to (c).

PLC CPU processing time =

$$\frac{(\text{Specified number of points}) \div (\text{Number of points processed in one sequence program scan})}{\text{Rounded off below the decimal point}} \times (\text{Scan time})$$

Remote node ACK: This is the time from the PLC CPU data read/write end time until the remote node returns a ACK.

[Example calculation 1]

The minimum transmission delay time (Scan time is 10ms, and includes its lengthened time shown in (c).) when reading data register (D) of 100 points of data while using the UDP/IP's binary code for the exchange protocol.

Command data length = 21 bytes

Response data length = 211 bytes

PLC CPU processing time = $\frac{100}{480} \times 10 = 10 \text{ (ms)}$
 ≈ 1

Minimum transmission delay time = $14 + (0.010 \times 21) + (0.006 \times 211) + 10$
 $\approx 25 \text{ (ms)}$

[Example calculation 2]

The minimum transmission delay time (Scan time is 10ms, and includes its lengthened time shown in (c).) when writing 100 points of data to the data register (D)100 using the UDP/IP's binary code for the exchange protocol.

Command data length = 221 bytes

Response data length = 11 bytes

PLC CPU processing time = $\frac{100}{480} \times 10 = 10$ (ms)
 ≈ 1

Minimum transmission delay time = $14 + (0.010 \times 221) + (0.006 \times 11) + 10$
 ≈ 26 (ms)

(c) Lengthened time of the scan time

This is the time in which the PLC CPU main module can process the number of points for one time for each end when running for the request from the QE71 (Refer to Item 9.2).

The following table shows the interrupt time during the scan time and the number of scans required for processing.

① For QE71 commands

Item	Com- mand	Sub- com- mand	Intervening time [ms] (Scan time increase)			Number of scans required for processing				Maximum number of points that can be processed between the QE71 and a remote node.*3	Number of processes that can be conducted during one scan of the sequence program.*3	
			Q3ACPU (When A38B Used)		Number of access points ①/②	When [Enable during RUN] set		When [Disable during RUN] set				
			Number of access points: ①	Number of access points: ②								
Device memory	Batch read	Bit units	0401	0001	1.068	2.428	1/3584	1		1792/3584/256 points		
		Word units		0000	0.996	3.168	1/480	1		480/32 words 480/64 points		
	Batch write	Bit units	1401	0001	1.008	2.428	1/3584	1	2	1792/3584/160 points		
		Word units		0000	0.996	3.196	1/480	1	2	480/10 words 480/64 points		
	Random read	Word units	0403	0040	1.304	6.976	1/96	3	4	96/10 words		
				0000	1.272	7.256		2	3	96/10 points		
	Test [Random write]	Bit units	1402	0001	1.240	9.160	1/94	1	2	94/20 points		
		Word units		0000	1.156	6.764	1/80	1	2	960/10 words 960/10 points		
	Monitor data register	Word units	0801	0040	0.980	0.990	1/96	1				96/20 words
				0000	0.948	0.950						94/20 points
	Monitor condition	Word units	0802	0000	1.320	0.932	1/96	Monitor condition		Monitor condition		Number of registered points portion
					1.212	7.256		Yes	No	Yes	No	
					2	1	2	1				
	Multiple block batch read	Word units	0406	0000	1.250	16.400	1/480 (*1)	1				480 words
Multiple block batch write	Word units	1406	0000	1.280	13.460	1/96 (*2)	1	2		480 words		

*1 Number of blocks ① = 1, Number of blocks ② = 120

*2 Number of blocks ① = 1, Number of blocks ② = 96

Item	Command	Sub-command	Intervening time [ms] (Scan time increase)			Number of scans required for processing				Maximum number of points that can be processed between the QE71 and a remote node. *3	Number of processes that can be conducted during one scan of the sequence program. *3			
			Q3ACPU (When A38B Used)		Number of access points ①/②	When [Enable during RUN] Set		When [Disable during RUN] Set						
			Number of access points:①	Number of access points:②		FILE No. specification		FILE No. specification						
					FFFFH	YES	FFFFH	YES						
Buffer memory	Batch read	0613	0000	—		—		—		480 words				
	Batch write	1613	0000	—		—		—		480 words				
PLC CPU	Remote run	1001	0000	—		1		—		1 station				
	Remote stop	1002	0000	—		1		—		1 station				
	Remote pause	1003	0000	—		1		—		1 station				
	Remote latch clear	1005	0000	—		1		—		1 station				
	Remote reset	1006	0000	—		1		—		1 station				
Drive memory	Memory usage state read	0205	0000	1.072	2.480	1/256		1		256 clusters				
	Memory optimization	1207	0000	—		—		1	2	1 station				
File	File information list read	Without header statement	0201	0000	1.104	3.324	1/36		1		36 items			
		With header statement	0202	0000	1.192	4.132	1/16		1		16 items			
		File No. usage state	0204	0000	1.376		1		1		256 items			
	File information change	Data of last updating	1204	0000	1.136		1		2	1	3	2	1 items	
		File name size change		0001	1.252		1		2	1	3	2	1 items	
		Batch change		0002	1.196		1		2	1	3	2	1 items	
	File search	0203	0000	1.020		1		1		—		1 items		
	File contents read	0206	0000	1.164	3.228	1/960		2	1	2	1	960 bytes		
	File register (Filename write)	1202	0000	1.376		1		1		2		1 items		
	File contents write	Arbitrary data	1203	0000	1.168	3.296	1/960		2	1	3	2	960 bytes	
		Same data (FILL)		0001	1.200	1.336	1/960		2	1	3	2	File size portion	
	File lock register/clear		0808	0001	0.996		1		2	1	3	2	1 items	
				0000	1.000		—		—		—			
	File copy	1206	0000	1.388	1.540	1/480		1 only	Both	1	1 only	Both	2	480 bytes
	File delete	1205	0000	1.152		1		2	1	3	4	2	1 items	
EEPROM	Read	0610	0000	—		—		—		—		960 bytes		
	Write	1611	0000	—		—		—		—				
LED Turned Off	1617	000□	—		—		—		—		1 station			
Loopback Test	0619	0000	—		—		—		—		960 bytes			

*3 When the QE71 command is used, the number of maximum processing points between the QE71 and a remote node and the number of processing points during one scan of the sequence program are the same, and the number changes depending on the access station. Refer to Item 9.2.1 for the processing points in accordance with the access station.

② For E71 commands

Item			Com- mand	Intervening time [ms] (Scan time increase)			Number of scans required for processing		Maximum number of points that can be processed between the QE71 and a remote node.	Number of processes that can be conducted during one scan of the sequence program.
				Q3ACPU (When A38B Used)		Number of access points ①/②	When [Enable during RUN] set	When [Disable during RUN] set		
				Number of access points : ①	Number of access points : ②					
Device memory	Batch read	Bit units	00H	1.032	1.132	1/256	1		256 points	256 points
		Word units	Bit device	01H	1.040	1.192	1/32	1		128 words
	Word device		256 points							64 points
	Batch write	Bit units	02H	1.072	1.144	1/160	1	2	256 points	256 points
		Word units	Bit device	03H	1.028	1.104	1/10	1	2	40 words
	Word device		256 points							64 points
	Test (Random write)	Bit units	04H	1.260	2.876	1/20	1	2	80 points	20 points
		Word units	Bit device	05H	1.232	1.876	1/10	1	2	40 words
	Word device		40 points							10 points
	Monitor data register	Bit units	06H	—			0		—	—
Word units		Bit device	07H	—		—			—	
	Monitor	Bit units				08H	1.312	2.488	1/20	1
Word units		Bit device	09H	1.260	2.452	1/20	1		20 words	20 words
	Word device	20 points							20 points	
Ex- tended file register	Batch read		17H	1.044	1.276	1/64	1		256 points	64 points
	Batch write		18H	1.048	1.368	1/64	1	2	256 points	64 points
	Test (Random write)		19H	1.172	1.896	1/10	2		40 points	10 points
	Monitor data register		1AH	—			—		—	—
	Monitor		1BH	1.280	2.504	1/20	1		20 points	20 points
	Direct read	Word units	3BH	0.980	1.328	1/64	1		256 points	64 points
	Direct write	Word units	3CH	1.056	1.344	1/64	1	2	256 points	6 points

Point

- (1) The PLC CPU can only process one of the above items during END processing. When the corresponding PLC CPU is accessed at the same time by GPP or other modules etc., they must wait until the other processing is completed, so the number of scans required for processing is increased. (Refer to Item 9.3 2).
- (2) When access to the remote station is requested via MELSECNET the number of scans required for processing decreases by 2 from the initial number. (Refer to Items 9.1.2 and 9.1.3.)

Appendix 4 ASCII Code Table

MSD \ LSD		0	1	2	3	4	5	6	7
		000	001	010	011	100	101	110	111
0	0000	NUL	DLE	SP	0	@	P	,	p
1	0001	SOH	DC1	!	1	A	Q	a	q
2	0010	STX	DC2	!!	2	B	R	b	r
3	0011	ETX	DC3	#	3	C	S	c	s
4	0100	EOT	DC4	\$	4	D	T	d	t
5	0101	ENQ	NAK	%	5	E	U	e	u
6	0110	ACK	SYN	&	6	F	V	f	v
7	0111	BEL	ETB	/	7	G	W	g	w
8	1000	BS	CAN	(8	H	X	h	x
9	1001	HT	EM)	9	I	Y	i	y
A	1010	LF	SUB	*	:	J	Z	j	z
B	1011	VT	ESC	+	;	K	[k	{
C	1100	FF	FS	,	<	L	/	l	
D	1101	CR	GS	—	=	M]	m	}
E	1110	SO	RS	.	>	N	↑	n	~
F	1111	SI	VS	/	?	O	←	o	DEL

Appendix 5 Reference Documents

For details regarding TCP/IP refer to the DDN Protocol Handbook (3 volumes).

Publisher

DDN Network Information Center
SRI International
333 Ravenswood Avenue, EJ291
Menlo Park, California 94025

RFC No.

TCP RFC793
UDP RFC768
IP RFC791
ICMP RFC792
ARP RFC826

Appendix 6 Diagram of External Dimensions

(1) AJ71QE71N3-T

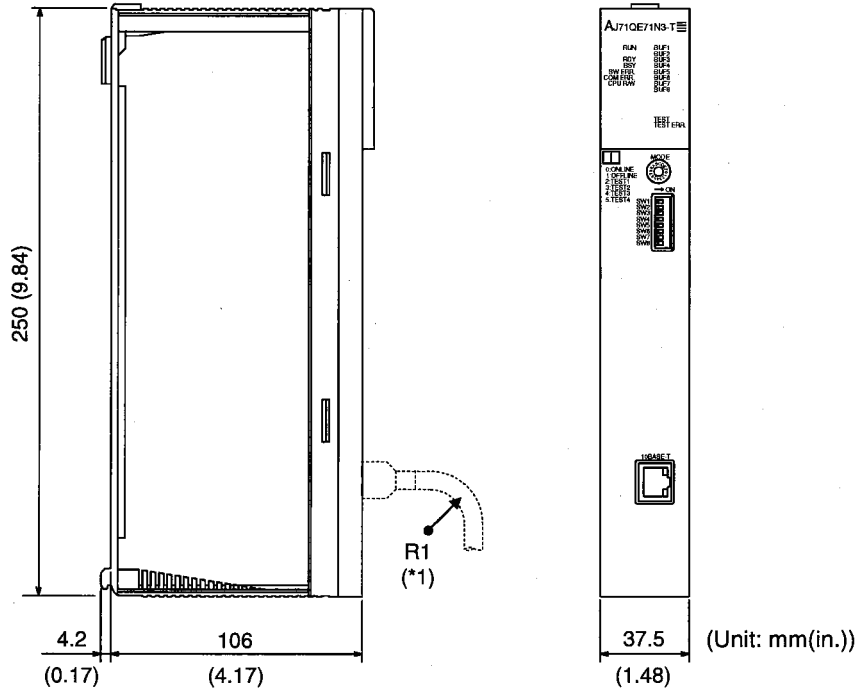

(2) AJ71QE71N-T

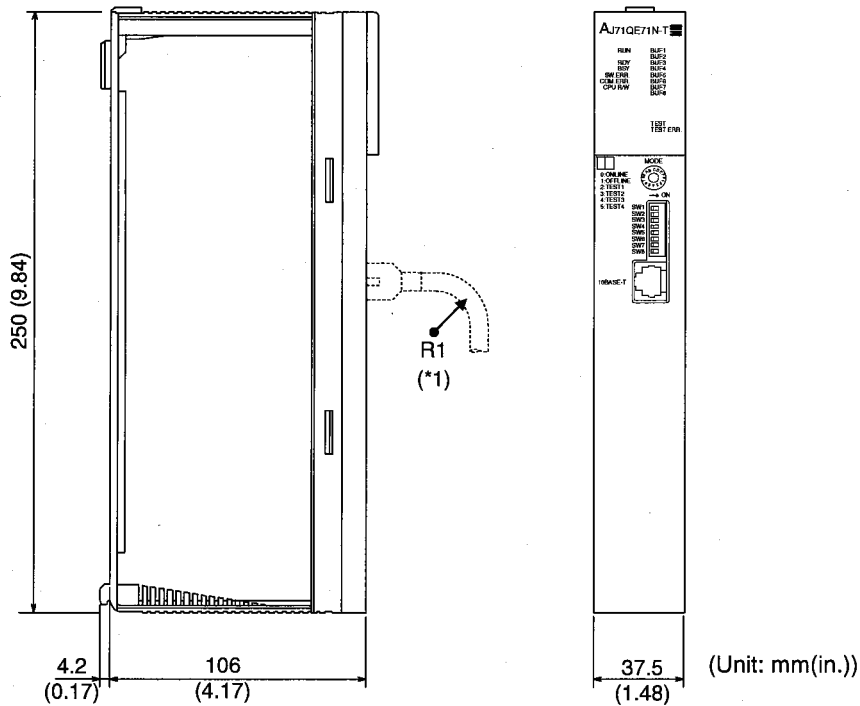

*1 When connecting the twisted pair cable, set the bending radius near the connector (reference value: R1) as four times the cable's outside diameter or larger.

(3) AJ71QE71N-B5

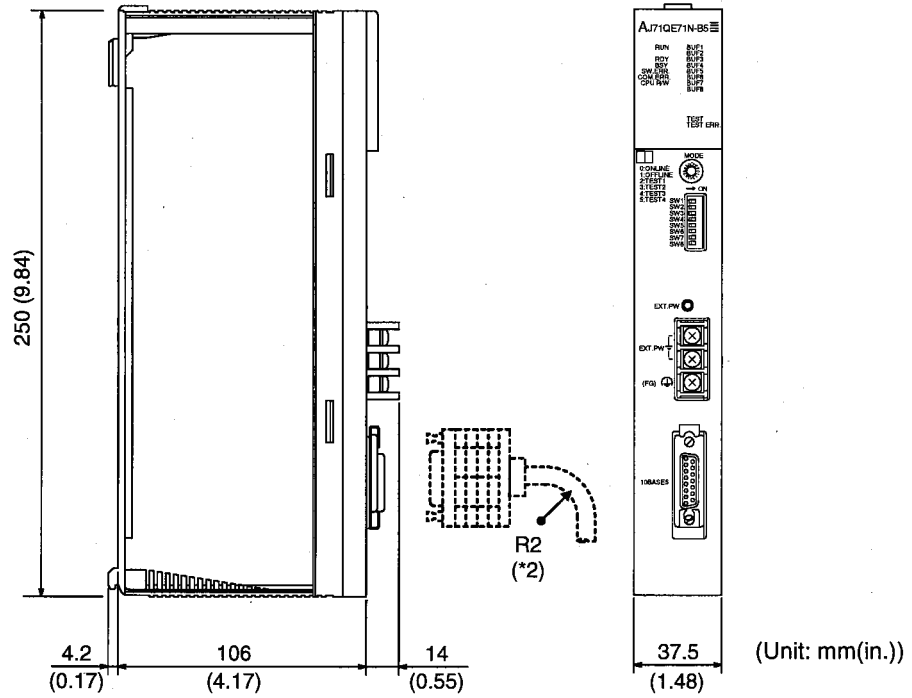

*2 When connecting the AUI cable, set the bending radius near the connector (reference value: R2) as four times the cable's outside diameter or larger.

(4) AJ71QE71N-B2

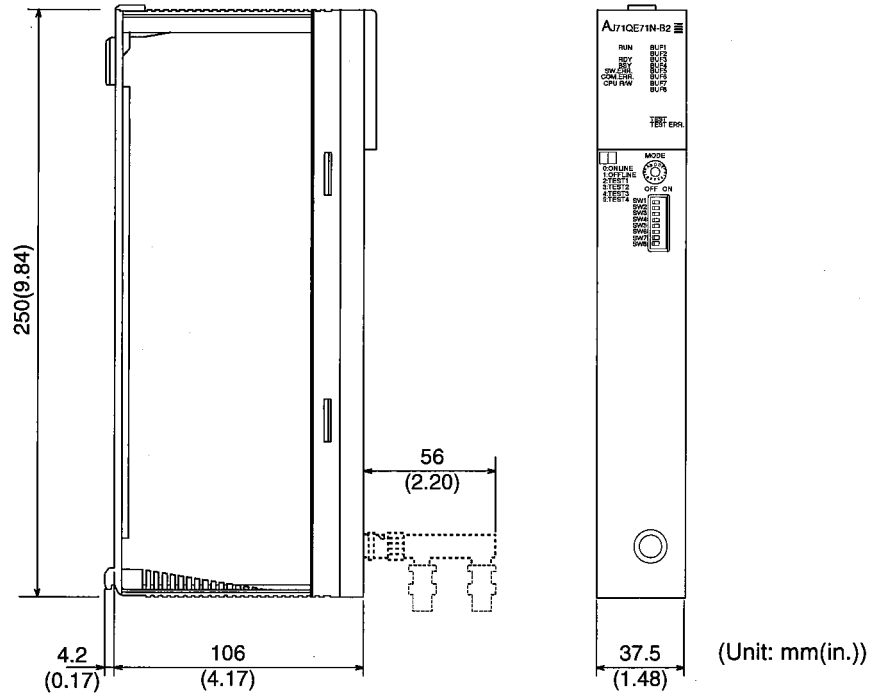

(5) A1SJ71QE71N3-T

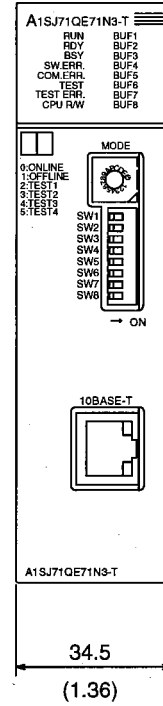
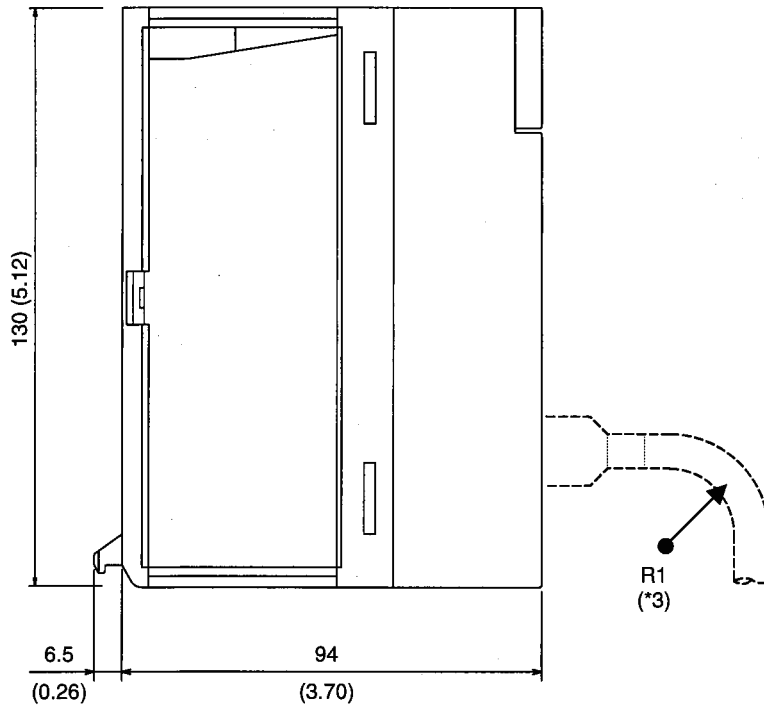

(Unit: mm(in.))

(6) A1SJ71QE71N-T

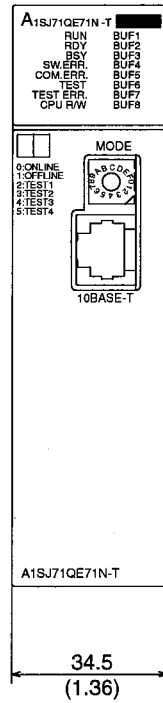
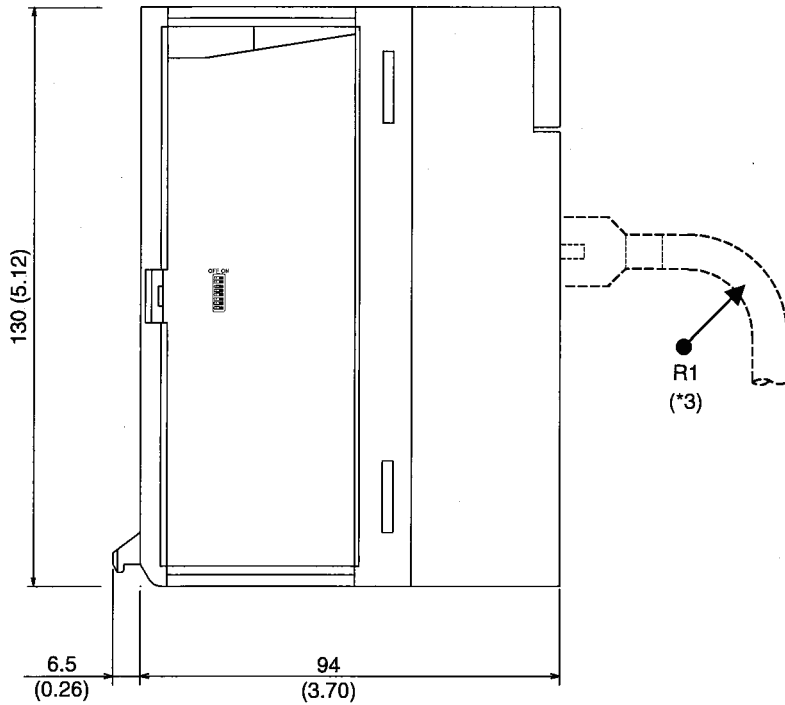

(Unit: mm(in.))

*3 When connecting the twisted pair cable, set the bending radius near the connector (reference value: R1) as four times the cable's outside diameter or larger.

(7) A1SJ71QE71N-B5

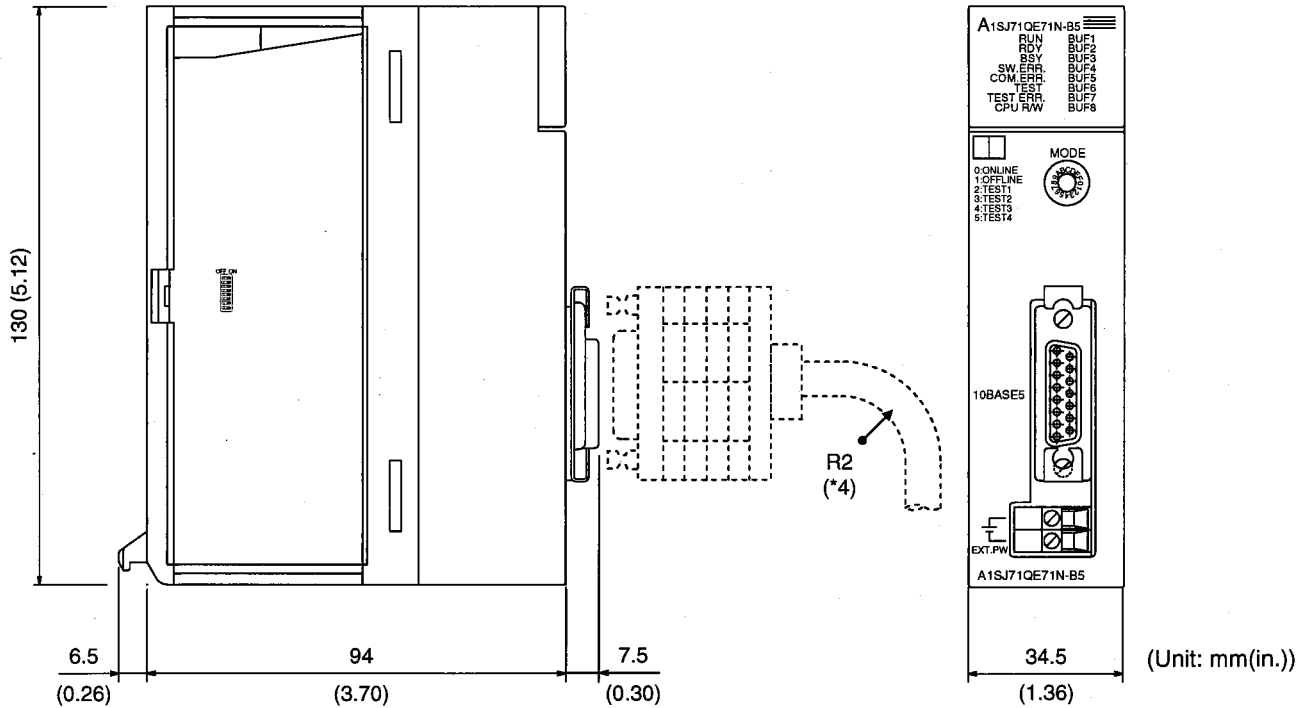

*4 When connecting the AUI cable, set the bending radius near the connector (reference value: R2) as four times the cable's outside diameter or larger.

(8) A1SJ71QE71N-B2

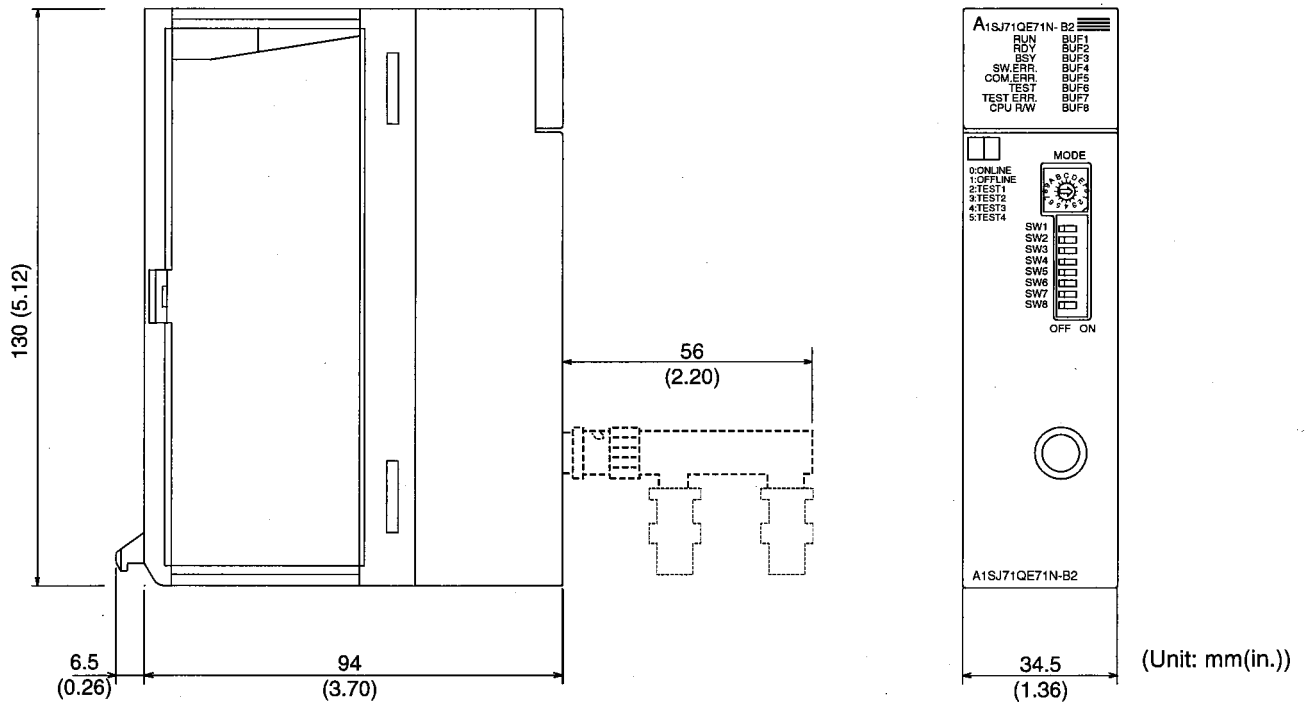

Appendix 7 Sample Program

This shows the sample program between the PLC CPU of the station installed in the QE71 and the remote node in order to conduct a connection test between the QE71 and a remote node (IBM PLC-AT) connected to the same Ethernet.

The programs only conduct the minimum processing required to conduct the exchange test. Change the IP address and the port No. to match those of the system. In addition, make separate additions when error processing, etc., is included.

- PLC CPU side : Make additions as explained in Chapters 5 and 17 of this manual.
- DOS/V personal computer side : Make additions to match the system specifications.

1 Reception processing of remote node

An example of reception processing on the remote node side is shown below.

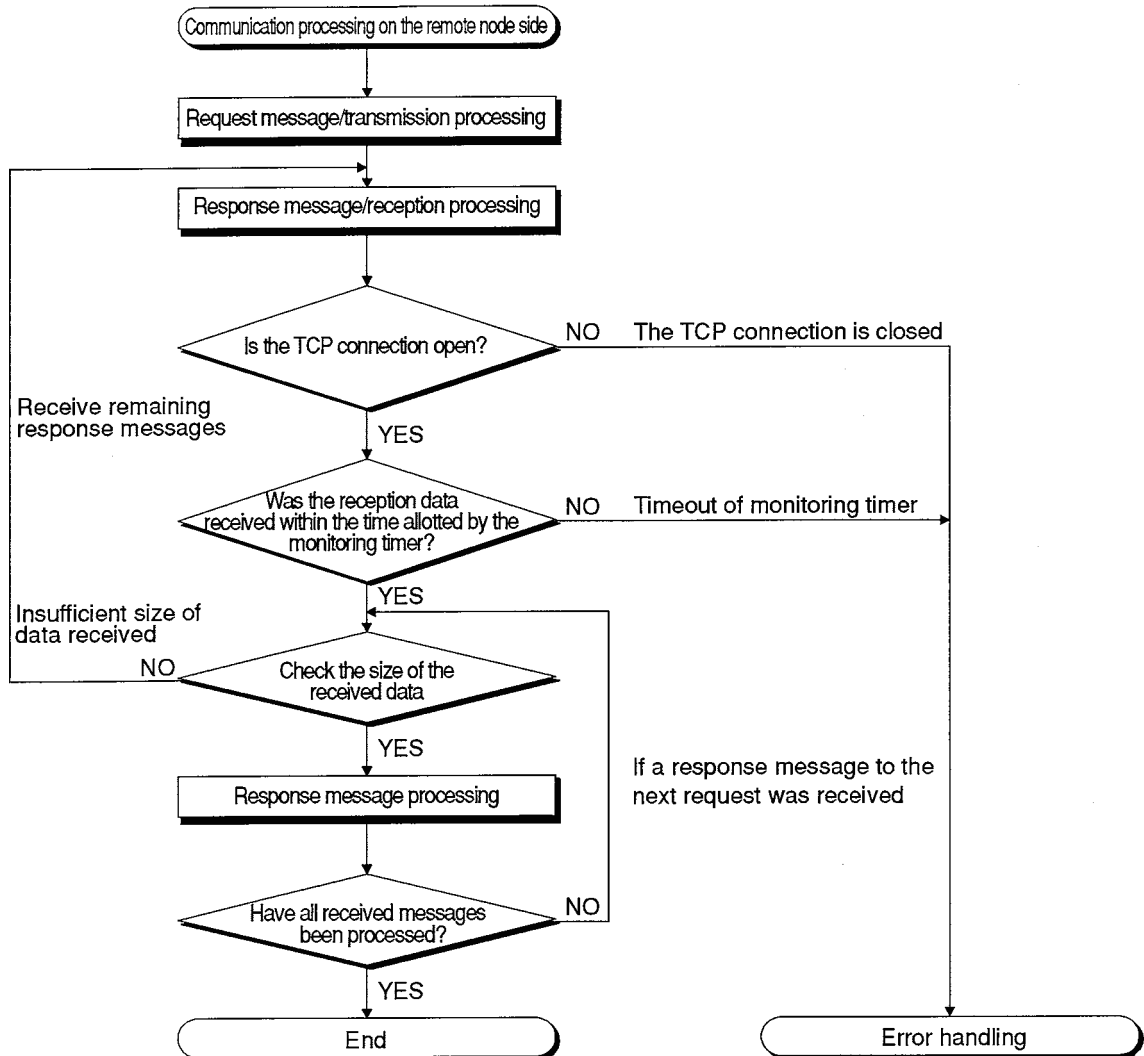

Background

For Ethernet communications, the TCP socket functions are used inside the personal computer. However, these functions do not have any limits. Therefore, when the "send" function is executed once to transmit data, the receiving end (node) needs to execute the "recv" function once or more in order to read the data ("send" and "recv" is not proportional to 1:1 execution). For this reason, the receiving procedure explained above, is required.

2**When the reception processing of the remote node is incompatible**

When the reception processing of the remote node is not as described in above **1**, communication under the "Enable TCP Maximum Segment transmission" setting may cause the following:

- Normal data cannot be read if batch read is executed in read/write of PLC CPU data from the remote node.
- Normal data cannot be read after the QE71 that does not support TCP Maximum Segment transmission is replaced with a module that support it.
- Reception is disabled although the total number of received TCP packets (address: 1B8H,1B9H) in the buffer memory is updated.

In this case, change the setting to "Disable TCP Maximum Segment transmission".

Appendix 7.1 Program for Reading/Writing Data in the PLC CPU

The sample program or execution environment and data exchange contents are shown below.

1

Sample program execution environment

(a) PLC CPU side (*1)

- | | |
|--|--|
| ① PLC CPU model name of the station
installed in the QE71 | : Q3ACPU |
| ② QE71 I/O signal | : X/Y000 to X/Y01F |
| ③ Ethernet address | : Setting not required because there is an ARP function |
| ④ QE71 IP address | : C0.00.01.FD _H (192.00.01.253) |
| ⑤ QE71 port No. | : 2000 _H (8192) |
| ⑥ Exchange condition setting | : SW2 and SW7 are ON. The others are depending on the procedure. |

(b) Remote node (IBM PLC-AT) side

- | | |
|------------------------------------|---|
| ① Operation environment | : Microsoft® Windows®95 Operating System |
| ② Ethernet interface board name | : Board that supports WINSOCK |
| ③ Library | : WSOCK32.LIB |
| ④ Software development environment | : Uses Microsoft® Corporation's Visual C++ (Ver. 4.0) |
| ⑤ Ethernet address | : Setting not required because there is an ARP function |
| ⑥ IP address | : Reception when opening Active |
| ⑦ Port No. | : Reception when opening Active |

(c) Communication format

: TCP/IP

2

Sampling program overview

(a) PLC CPU side sequence program

Only conducts initial processing and open processing.

(b) Remote node (IBM PLC-AT) side program

The above library is used to conduct exchange for reading/writing data in the following PLC CPU.

- Writing in word units (for 5 points: D0 to D4) See Section 10.2.5.
- Reading in word units (for 5 points: D0 to D4) See Section 10.2.3.

(c) When exchanging ASCII code data is exchanged.

(*1) The QE71 switch settings are as follows.

Setting switch			Setting value	Setting description
Operation mode setting switch			0	Online
Exchange condition setting switches	SW1	Line processing selection during TCP timeout error	OFF	Closes
	SW2	Data code setting	ON	ASCII code
	SW3	Automatic startup mode setting	OFF	Operate in accordance with Y19.
	SW7	CPU exchange timing setting	ON	Write enable
	SW8	Initial timing setting	OFF	Quick start

(Set all switches SW4 to SW6 (use not possible) to off.)

3 Sequence program

Following is an example of QE71 installed station Q3ACPU sequence program.

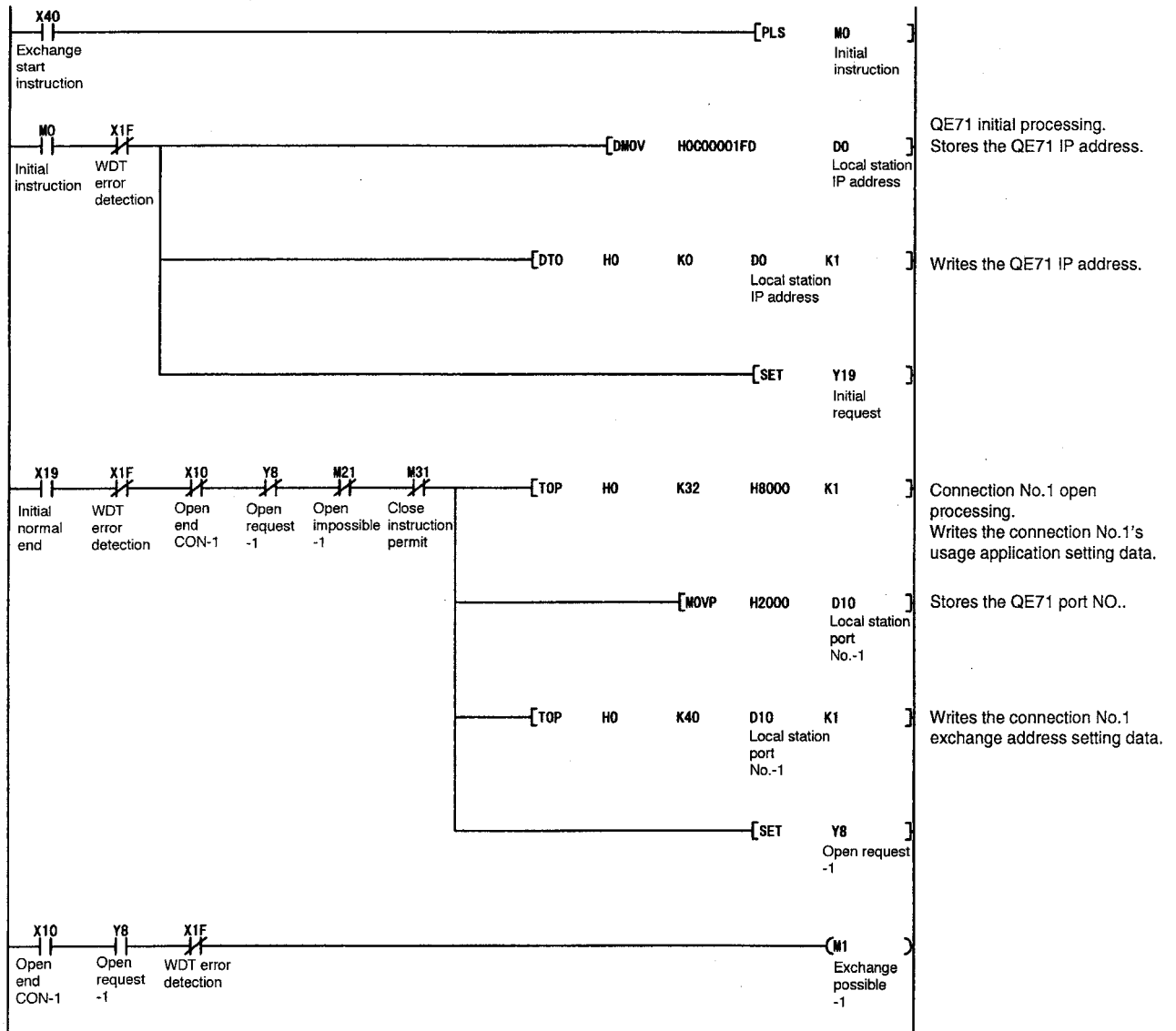

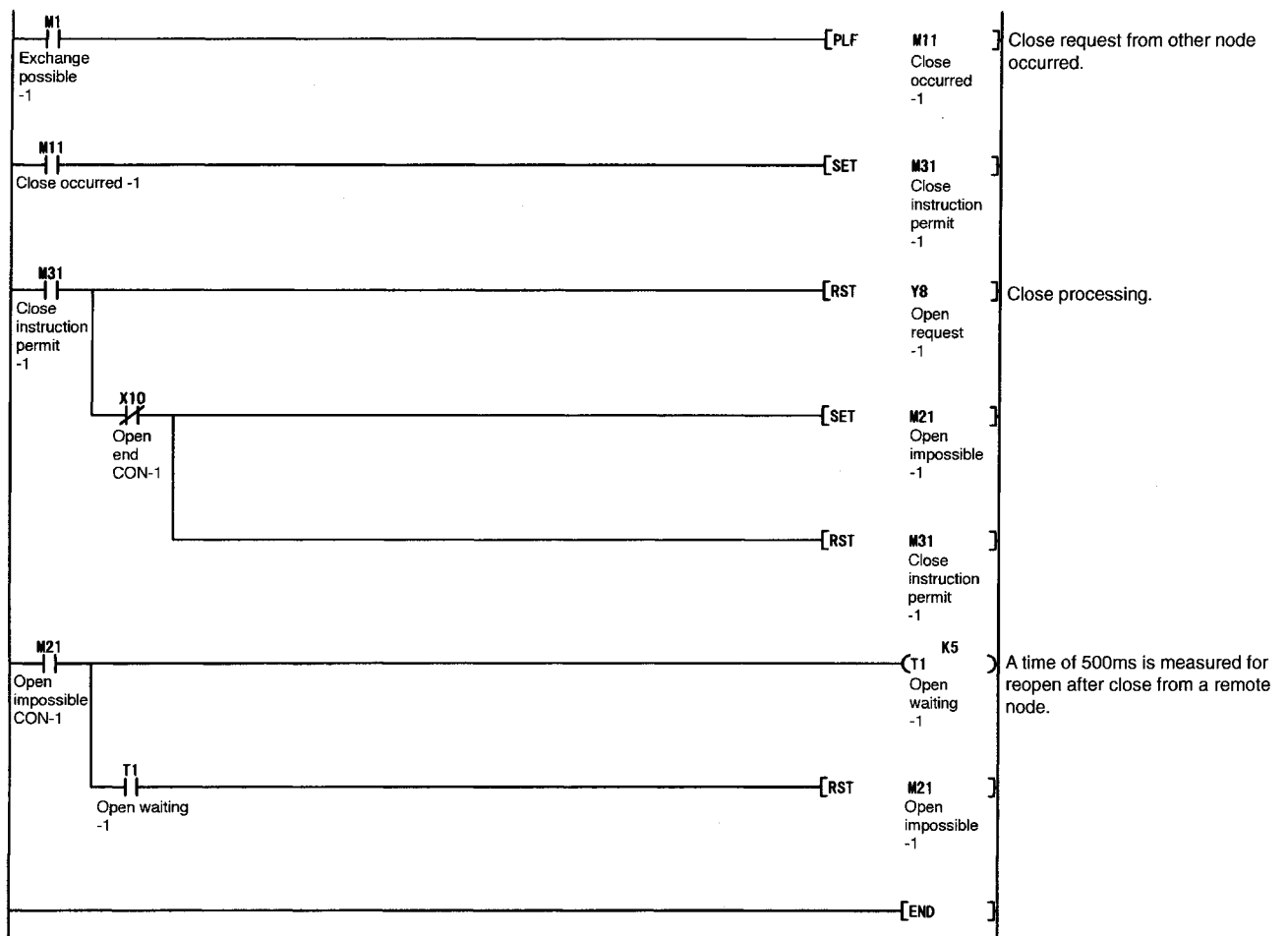

4 Remote node (IBM PLC-AT) side program

Following is an example remote node program for accessing a Q3ACPU while the station installed in the QE71.

Executing this program displays in order the following exchange text contents.

- ① Word unit batch write command message
- ② Word unit batch write response message
- ③ Word unit batch read command message
- ④ Word unit batch read response message

Remarks

(1) Following is a summary of the compiling procedure for the program created using Microsoft®Corporation's Visual C++ (Ver. 4.0).

- ① Boot up Visual C++.
- ② Conduct program creation preparation.
Select file to new file and create a console application from the project work space screen.
- ③ Open the AJSAMP.C file and create a program. (Refer to the example program on the next page.)
- ④ Execute compiling for the program created from the build menu compile screen.
- ⑤ Link the WSOCK32.LIB from the build menu setting screen.
- ⑥ Create an execute file (AJSAMP.EXE) at the build menu build screen.
- ⑦ End Visual C++.
- ⑧ Execute AJSAMP.EXE.

(2) General procedure for cocket routine call

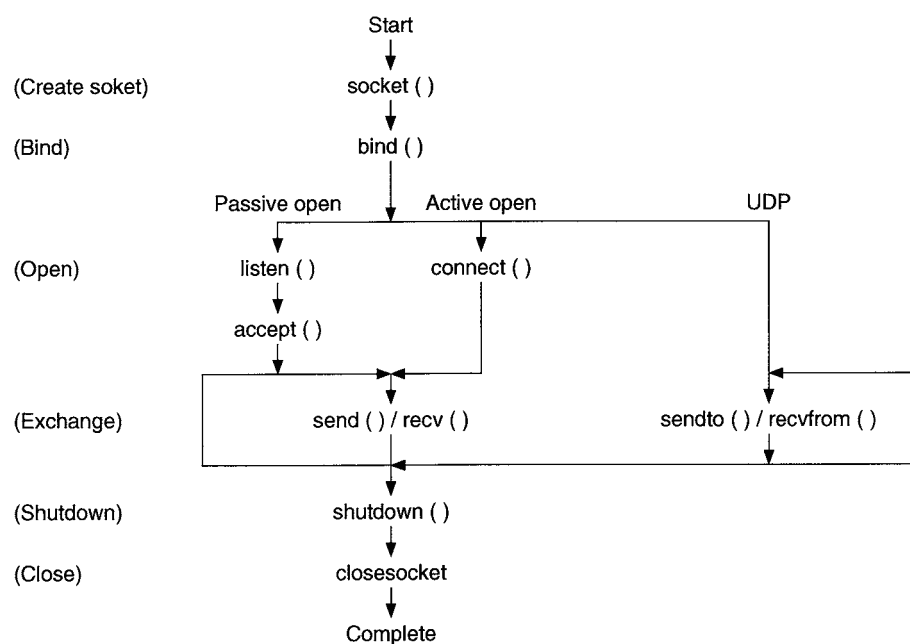

```

/*****
/**
/**      sample program
/**
/**      This program is a sample program to conduct a
/**      connection test between the QE71 and remote node.
/**      This program accesses the data register (D) of
/**      the PLC CPU installed together with the QE71.
/**
/**
/**      Copyright (C) 1996 Mitsubishi Electric
/**      Corporation
/**      All Rights Reserved
/**
/*****

#include <stdio.h>
#include <winsock.h>

#define FLAG_OFF          0      // Completion flag OFF
#define FLAG_ON           1      // Completion flag ON
#define SOCK_OK           0      // Normal completion
#define SOCK_NG           -1     // Abnormal completion
#define BUF_SIZE         4096   // Receive buffer size

#define ERROR_INITIAL     0      // Initial error
#define ERROR_SOCKET      1      // Socket creation error
#define ERROR_BIND        2      // Bind error
#define ERROR_CONNECT     3      // Connection error
#define ERROR_SEND        4      // Send error
#define ERROR_RECEIVE     5      // Receive error
#define ERROR_SHUTDOWN    6      // Shutdown error
#define ERROR_CLOSE       7      // Line close error

//Definitions for checking the receiving sizes
//#define  RECV_ANS_1   4 // Receiving size of response message in reply to device write (1E frame)
#define  RECV_ANS_1   22 // Receiving size of response message in reply to device write (3E frame)
//#define  RECV_ANS_2   24 // Receiving size of response message in reply to device read (1E frame)
#define  RECV_ANS_2   42 // Receiving size of response message in reply to device read (3E frame)

typedef struct sck_inf{
    struct in_addr my_addr;
    unsigned short my_port;
    struct in_addr aj_addr;
    unsigned short aj_port;
};

```

```

int nErrorStatus;           // Error information storage variable
int Dmykeyin;              // Dummy key input
int Closeflag;            // Connection completion flag
int socketno;

int main()
{
    WORD wVersionRequested=MAKEWORD(1,1);    // Winsock Ver 1.1 request
    WSADATA wsaData;
    int length;                            // Communication data length
    unsigned char s_buf[BUF_SIZE];         // Send buffer
    unsigned char r_buf[BUF_SIZE];        // Receive buffer
    int rbuf_idx;                          // Receive data storage head index
    int recv_size;                         // Number of receive data
    struct sock_inf sc;
    struct sockaddr_in hostdata;           // Remote node side data
    struct sockaddr_in aj71e71;          // QE71 side data
    void Sockerror(int);                  // Error handling function

    unsigned long ulCmdArg ;              // Non-blocking mode setting flag

    sc.my_addr.s_addr=htonl(INADDR_ANY);   // Remote node side IP address
    sc.my_port=htons(0);                   // Remote node side port number
    sc.aj_addr.s_addr=inet_addr("192.0.1.253"); // QE71 side IP address
                                                // (C00001FDH)
    sc.aj_port=htons(0x2000);              // QE71 side port number

    Closeflag=FLAG_OFF;                   // Connection completion flag off

    nErrorStatus=WSAStartup(wVersionRequested,&wsaData); // Winsock Initial processing

    if(nErrorStatus!=SOCK_OK) {
        Sockerror(ERROR_INITIAL);          // Error handling
        return(SOCK_NG);
    }

    printf("Winsock Version is %ld.%ld\n",HIBYTE(wsaData.wVersion),LOBYTE(wsaData.wVersion));
    printf("AJ_test Start\n");

    socketno=socket(AF_INET,SOCK_STREAM,0); // Create socket for TCP/IP

    if(socketno==INVALID_SOCKET){
        Sockerror(ERROR_SOCKET);           // Error handling
        return(SOCK_NG);
    }

    hostdata.sin_family=AF_INET;
    hostdata.sin_port=sc.my_port;
    hostdata.sin_addr.s_addr=sc.my_addr.s_addr;

```

```

if(bind(socketno, (LPSOCKADDR)&hostdata, sizeof(hostdata))!=SOCK_OK){
    // Bind
    Sockerror(ERROR_BIND); // Error handling
    return(SOCK_NG);
}

aj71e71.sin_family=AF_INET;
aj71e71.sin_port=sc.aj_port;
aj71e71.sin_addr.s_addr=sc.aj_addr.s_addr;

if(connect(socketno, (LPSOCKADDR)&aj71e71, sizeof(aj71e71))!=SOCK_OK){
    // Connection (Active open)
    Sockerror(ERROR_CONNECT); // Error handling
    return(SOCK_NG);
}

Closeflag=FLAG_ON; // Connection completion flag ON

// Set to non-blocking mode
ulCmdArg = 1;
ioctlsocket(socketno, FIONBIO, &ulCmdArg); // Set to non-blocking mode

// strcpy(s_buf, "03FF000A4420000000000500112233445566778899AA");
// // D0 to D4 batch write request (1E frame)
strcpy(s_buf, "500000FF03FF00002C000A14010000D*0000000005112233445566778899AA");
// // D0 to D4 batch write request (3E frame)

length=strlen(s_buf);

if(send(socketno, s_buf, length, 0)==SOCKET_ERROR){ // Data sending
    Sockerror(ERROR_SEND); // Error handling
    return (SOCK_NG);
}
printf("\n send data\n%s\n", s_buf);

// Perform receiving size check and receiving processing simultaneously
rbuf_idx = 0; // Receive data storage head index initialization
recv_size = 0; // Initialize the number of receive data
while(1) {
    length = recv(socketno, &r_buf[rbuf_idx], (BUF_SIZE - rbuf_idx), 0);
    // Response data receiving
    if(length == 0) { // Is connection cut off?
        Sockerror(ERROR_RECIEVE); // Error handling
        return (SOCK_NG);
    }
}

```

```

        if(length == SOCKET_ERROR) {
            nErrorStatus = WSAGetLastError();
            if(nErrorStatus != WSAEWOULDBLOCK) {
                Sockerror(ERROR_RECIEVE); // Error handling
                return (SOCK_NG);
            } else {
                continue; // Repeat until messages are received
            }
        } else {
            rbuf_idx += length; // Update the receive data storage
                                // position
            recv_size += length; // Update the number of receive data
            if(recv_size >= RECV_ANS_1) // Have all response messages been
                                        // received?
                break; // Stop repeating as messages have
                        // been received
        }
    }
    r_buf[rbuf_idx] = '\0' ; // Set NULL at the end of receive data

    printf("\n receive data\n%s\n",r_buf);

// strcpy(s_buf, "01FF000A4420000000000500"); // D0 to D4 batch read request
//                                               // (1E frame)
strcpy(s_buf, "500000FF03FF000018000A04010000D*0000000005");
//                                               // D0 to D4 batch read request
//                                               // (3E frame)

length=strlen(s_buf);

if(send(socketno,s_buf,length,0)==SOCKET_ERROR){ // Data sending
    Sockerror(ERROR_SEND); // Error handling
    return (SOCK_NG);
}
printf("\n send data\n%s\n",s_buf);

// Perform receiving size check and receiving processing simultaneously
rbuf_idx = 0; // Receive data storage head index
              // initialization
recv_size = 0; // Initialize the number of receive data
while(1) {
    length = recv(socketno, &r_buf[rbuf_idx], (BUF_SIZE - rbuf_idx), 0);
                // Response data receiving
    if(length == 0) { // Is connection cut off?
        Sockerror(ERROR_RECIEVE); // Error handling
        return (SOCK_NG);
    }
}

```



```

    if(length == SOCKET_ERROR) {
        nErrorStatus = WSAGetLastError();
        if(nErrorStatus != WSAEWOULDBLOCK) {
            Sockerror(ERROR_RECIEVE);           // Error handling
            return (SOCK_NG);
        } else {
            continue;                           // Repeat until messages are received
        }
    } else {
        rbuf_idx += length;                     // Update the receive data storage
                                                // position
        recv_size += length;                   // Update the number of receive data
        if(recv_size >= RECV_ANS_2)           // Have all response messages been
                                                // received?
            break;                             // Stop repeating as messages have
                                                // been received
    }
}
r_buf[rbuf_idx] = '\0' ;                      // Set NULL at the end of receive data
printf("\receive data\n%s\n", r_buf);

    if(shutdown(socketno,2)!=SOCK_OK){        // Processing to disable
                                                // sending/receiving
        Sockerror(ERROR_SHUTDOWN);           // Error handling
        return(SOCK_NG);
    }

    if(closesocket(socketno)!=SOCK_OK){       // Close processing
        Sockerror(ERROR_CLOSE);              // Error handling
        return(SOCK_NG);
    }

    Closeflag=FLAG_OFF;                       // Connection completion flag off
    WSACleanup();                             // Release Winsock.DLL

    printf("\nAJ_test End.\n\n Normally completed. \n");
    printf("Press any key to exit the program.\n");
    Dmykeyin=getchar();                       // Wait for key input

    return(SOCK_OK);
}

void Sockerror(int error_kind)                 // Error handling function
{
    if(error_kind==ERROR_INITIAL){
        printf("Initial processing is abnormal.");
    }
}

```

```
else{
    nErrorStatus=WSAGetLastError();
    switch(error_kind){
    case ERROR_SOCKET:
        printf("Failed to create socket.");
        break;
    case ERROR_BIND:
        printf("Failed to bind.");
        break;
    case ERROR_CONNECT:
        printf("Failed to establish connection.");
        break;
    case ERROR_SEND:
        printf("Sending failed.");
        break;
    case ERROR_RECV:
        printf("Receiving failed.");
        break;
    case ERROR_SHUTDOWN:
        printf("Failed to shutdown.");
        break;
    case ERROR_CLOSE:
        printf("Failed to close normally.");
        break;
    }
}

printf("Error code is %d.\n", nErrorStatus);

if(Closeflag==FLAG_ON){
    nErrorStatus=shutdown(socketno,2); // Shutdown processing
    nErrorStatus=closesocket(socketno); // Close processing
    Closeflag=FLAG_OFF; // Connection completion flag off
}

printf("Press any key to exit the program.\n");
Dmykeyin=getchar(); // Wait for a key input
WSACleanup(); // Release Winsock.DLL
return;
}
```

Appendix 7.2 Sequence Programs for All Functions

An example of a common sequence program for conducting exchange (with procedure) using a fixed buffer memory, exchange using a random access buffer memory, and data read/write in the PLC CPU is shown below.

1 Sample program execution environment

The execution environment for the PLC CPU side setting value and switch setting, etc., is the same as the execution environment shown in Appendix 7.1 Item 1(a).

In addition, the port No. 2001H(8193) is used.

Freely set the IP Address on the remote node side. Use the same No. for the port No. as for the PLC CPU side.

2 Sample program overview

- ① Conducts initial processing.
- ② Conducts open processing. (Exchange while the PLC CPU is stopped is made possible.)
Two open processes are conducted to make possible exchange (transmission, reception) using a fixed buffer. In either case an Unpassive open is conducted and an Active open request from a remote node is awaited.
- ③ Exchange (transmission with procedure) using a fixed buffer, exchange using a random access buffer, and read/write data in the PLC CPU are conducted from the remote node. In addition, when not exchanging with the remote node, exchange (transmission with procedure) using a fixed buffer is conducted from the PLC CPU.
- ④ After data exchange is terminated, exchange will be prohibited while the PLC CPU is stopped and close processing will be conducted.
- ⑤ Termination processing is conducted after close processing is completed.

	Connection 1	Connection 2	Remark
QE71 IP Address	C0. 00. 01. FD		Class= C, Network address= 1, Host address= FDH
QE71 Port No.	2000H	2001H	Set the personal computer side to a free No.
Communication format	TCP/IP		Personal computer side is also TCP/IP
Open method	Unpassive	Unpassive	Personal computer side is Active open
Fixed buffer exchange	Transmission ready	Reception ready	—
Random access buffer exchange	Ready	Ready	Exchange is possible at either the connection 1 or connection 2.
Read/write data in the PLC CPU	Ready	Ready	

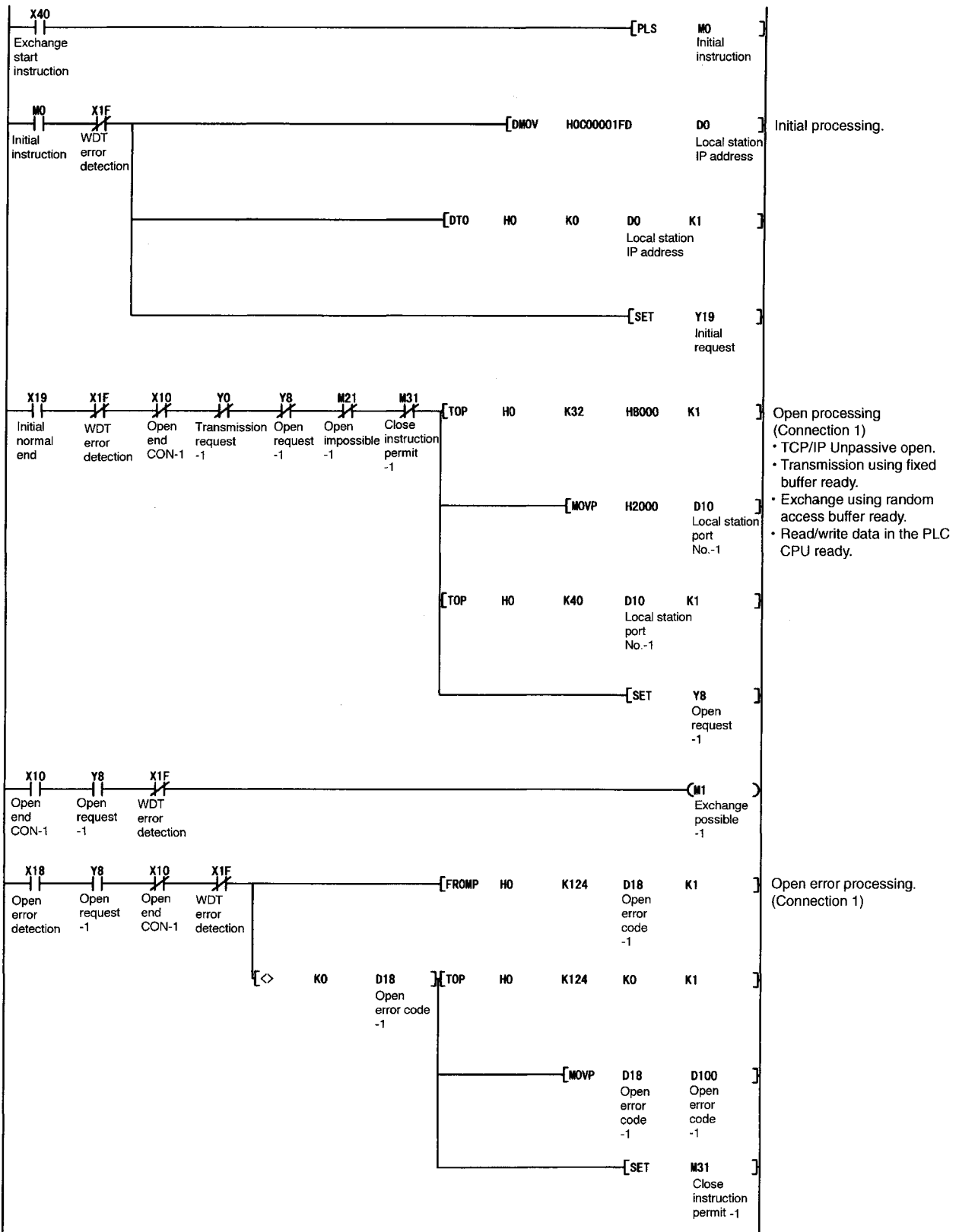

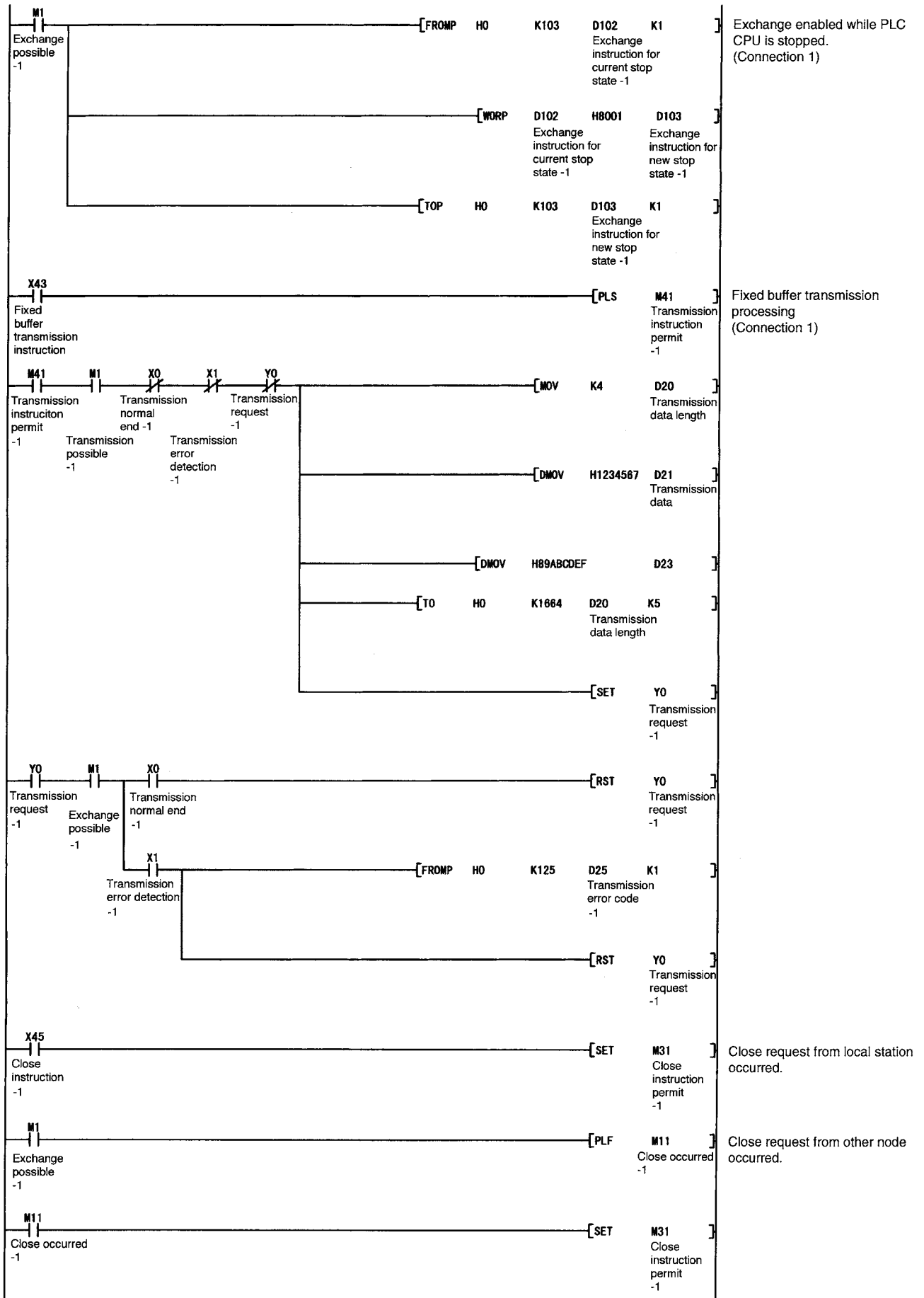

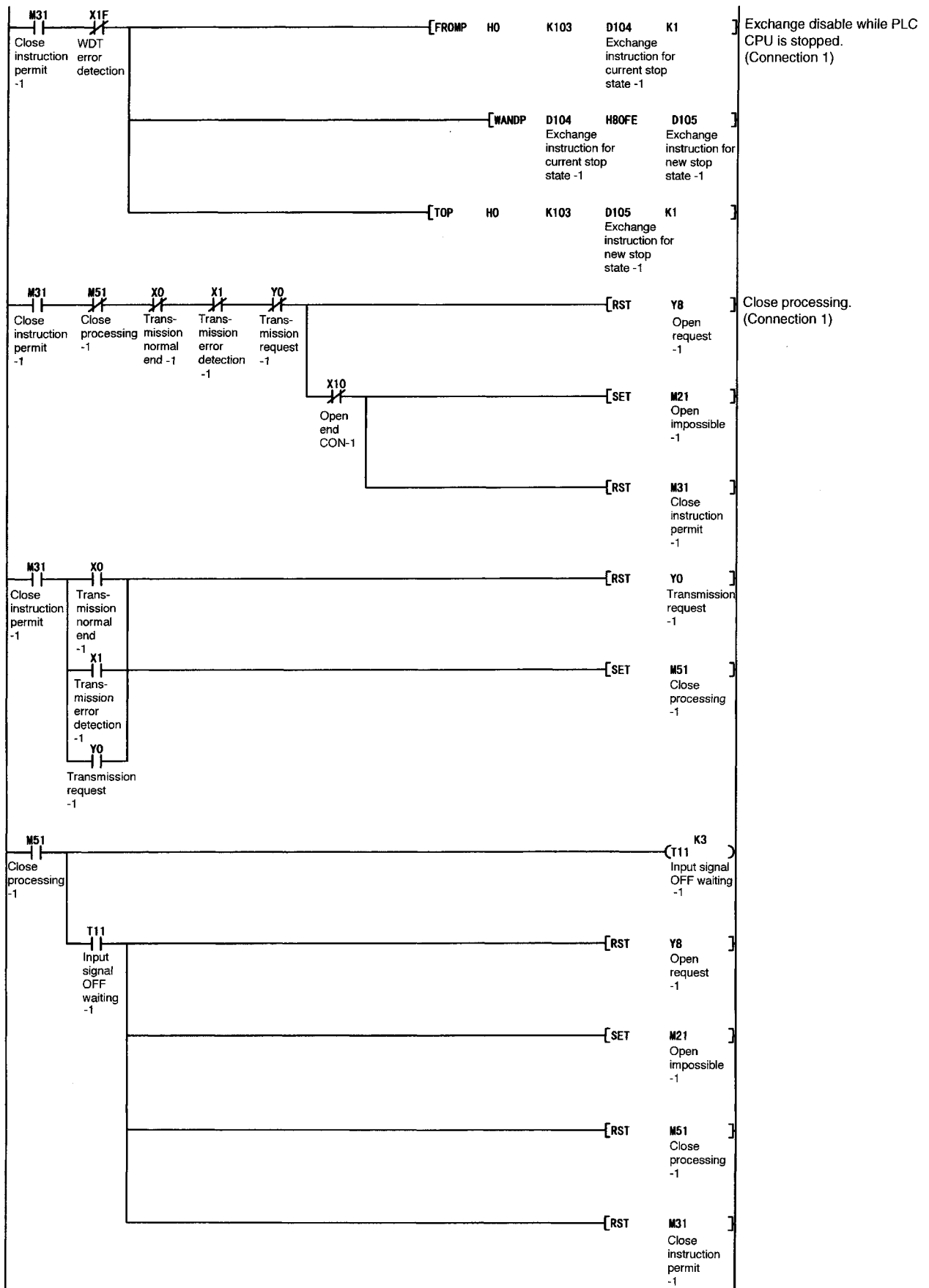

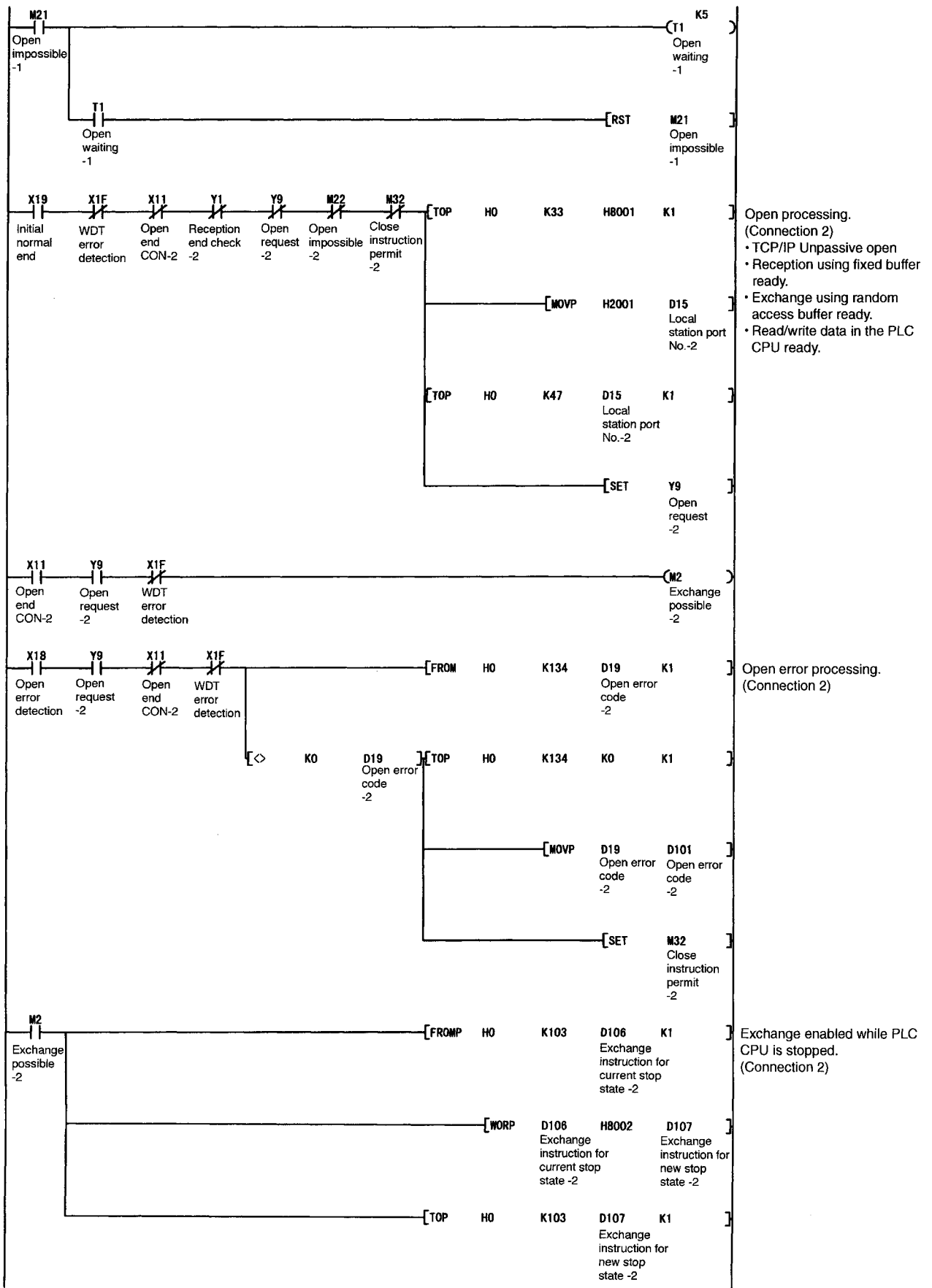

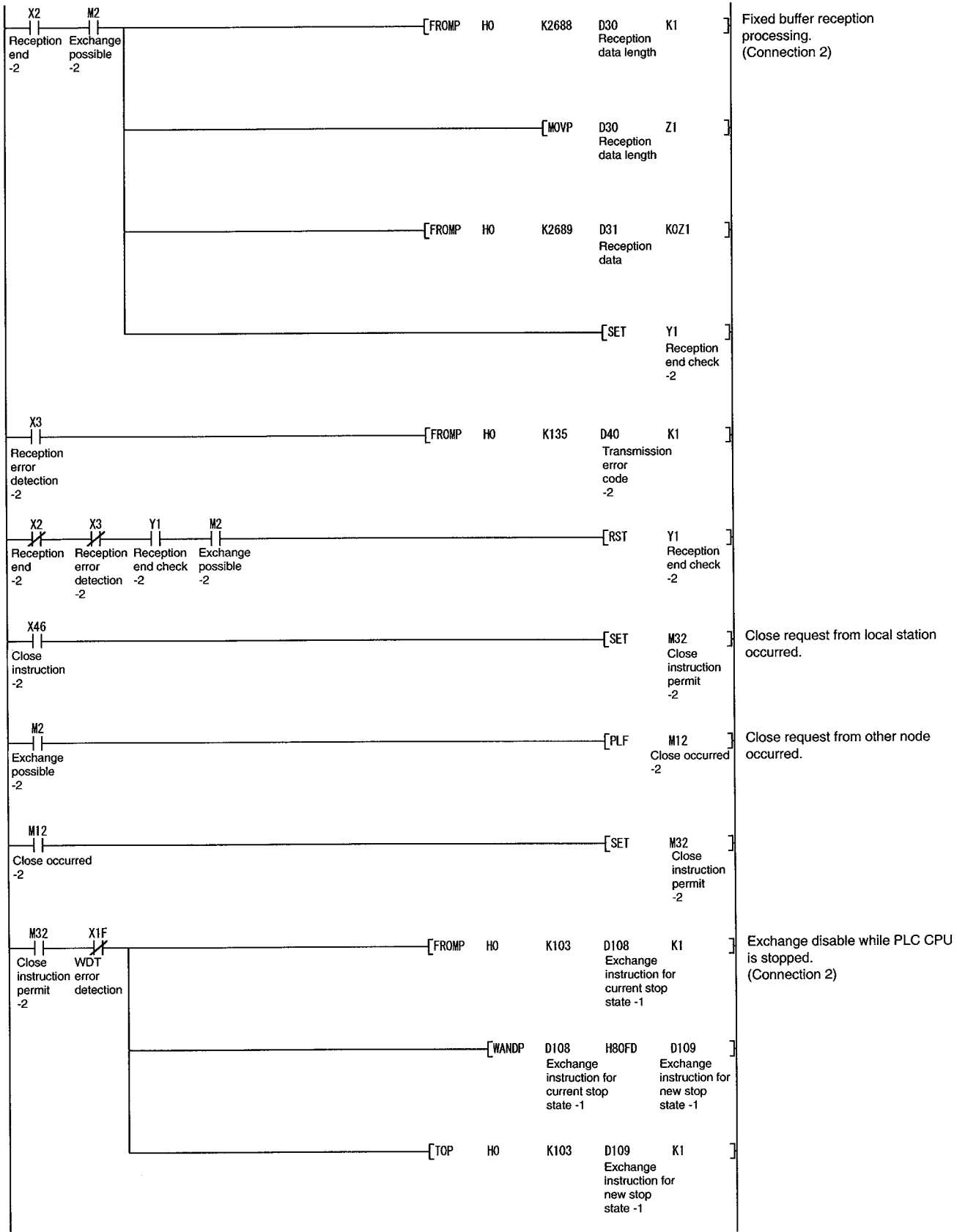

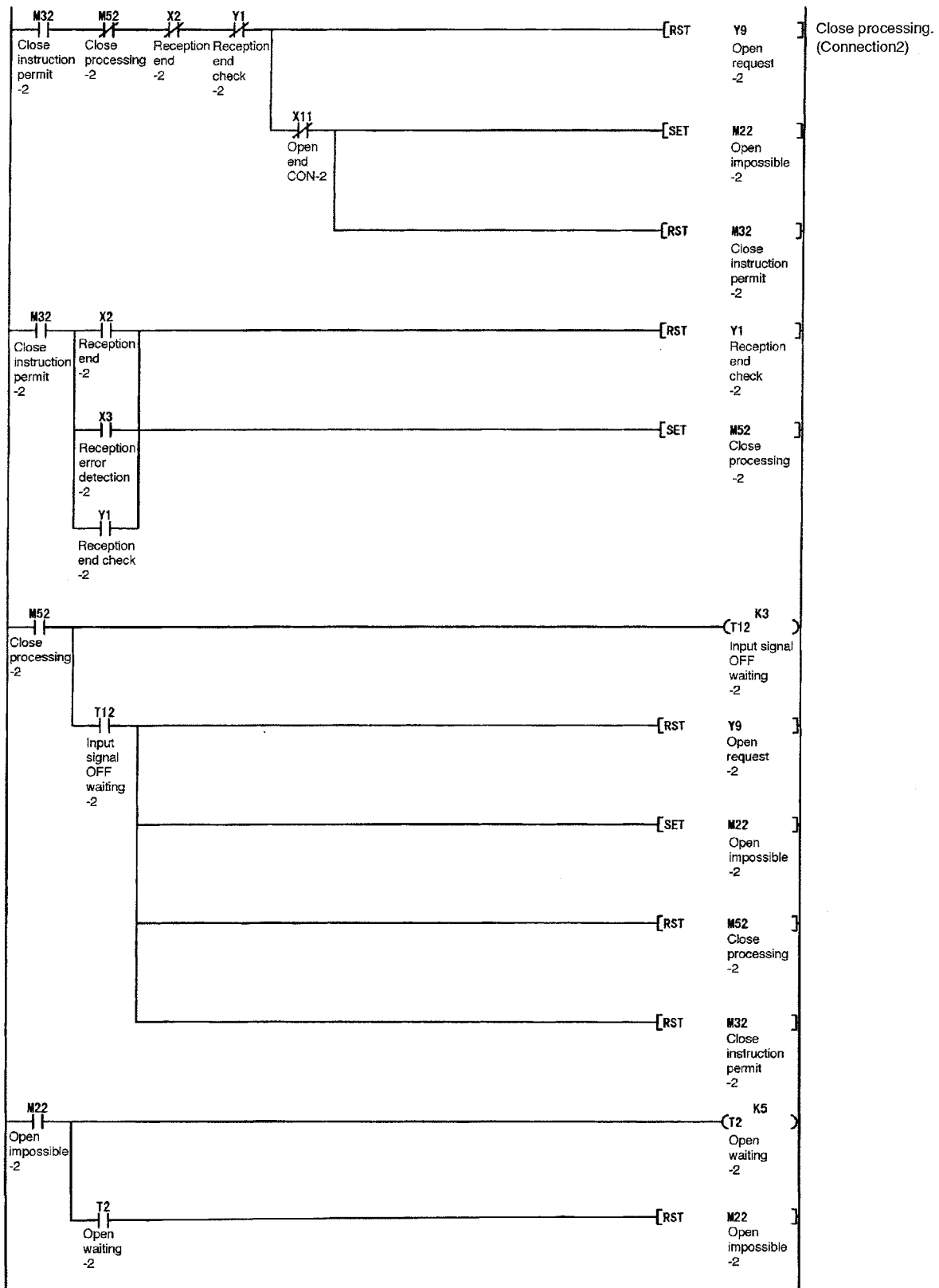

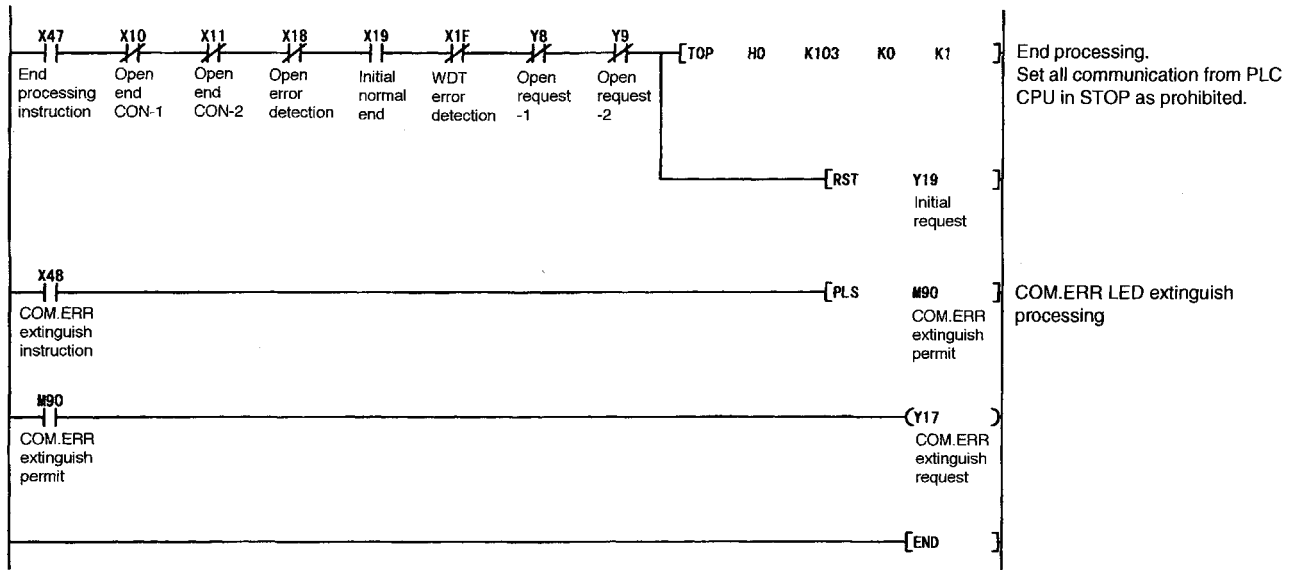

Appendix 7.3 Program for Reading/Writing Data in the PLC CPU

An example of the remote node side program that reads and writes data inside the PLC CPU is shown below. Also explained is the sample program, execution environment, and data exchange.

1 Sample program execution environment

- ① The setting values and the switch settings on the PLC CPU side are the same as for the execution environment shown in Appendix 7.1 Item 1(a).
- ② Except for the following software development environment the node side has the same execution environment as that described in Appendix 7.1 Item 1(b).
 - Software development environment : Microsoft® Corporation's visual basic (Ver.6.0) is used.
 - The IP Address and port No. are allocated free Nos.
- ③ The communication format is TCP/IP.

2 Overview of the sample program

This program reads data from D0 through D4 (five points) of the QnACPU of the station on which the QE71 is mounted with the E71 command (01: batch read in word units).

Note that the program shown in Appendix 7.2 is used as a program on the PLC CPU side.

3 Outline of the sample program

- (a) Create a new project and form.
- (b) Create the (example) window shown in (4) below using "Command Button" in the toolbox.
- (c) Add "Microsoft Winsock Control 6.0" using the component's control. Add a "Winsock" object from the toolbox to the form and set the Property Pages screen as follows:

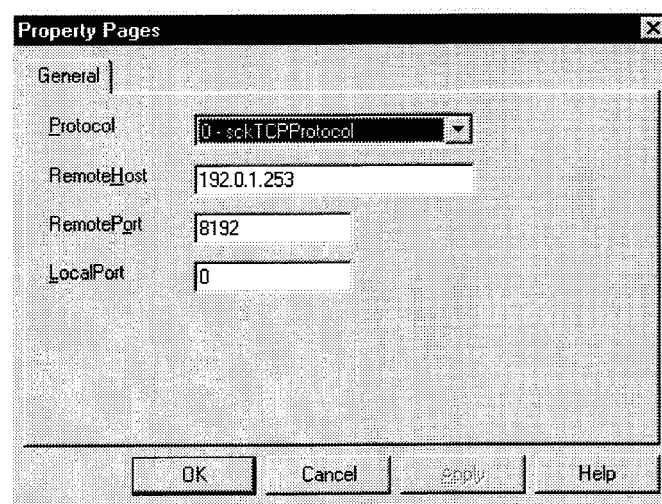

- (d) Create the program shown in (5).

4 Window example (Form 1)

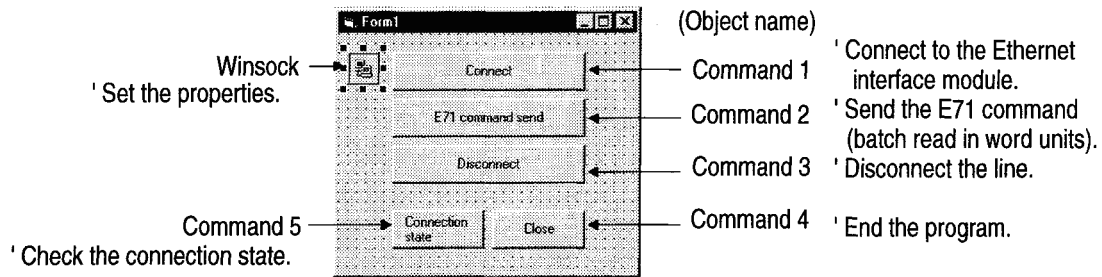

5 Sample program (Form 1)

Option Explicit

```
Private Sub Command1_Click()
'Connect to the Ethernet interface module
Me.Winsock1.Connect
```

End Sub

```
Private Sub Form_Load()
'When calling an Active open method from a PC to the Ethernet interface module,
'The property screen should be used or the settings performed as follows.
'Specify the protocol to be used.
'Winsock1.Protocol = sckTCPProtocol / sckUDPProtocol
'Specify the IP address of the Ethernet interface module.
'Winsock1.RemoteHost = "192.0.1.253"
'Specify the port No. used by the Ethernet interface module.
'Winsock1.RemotePort =8192:H2000
'If the open method of the Ethernet interface module is Fullpassive open,
'specify the set port No.
'If the open method of the Ethernet interface module is Unpassive open,
'"0" - use any port No.
'Winsock1.LocalPort = 0 :Unpassive open
```

End Sub

```
Private Sub winsock1_connect()
'Use the Connect event to perform confirmation processing at the time when the connection
processing is normally completed.
'The Connect event occurs when the connection processing is completed.
MsgBox "Connection Completed"
```

End Sub

```
Private Sub Command2_Click()
Dim SData As String
'Read D0 to D4 (5 points) with the E71 command.
SData = "01ff000a4420000000000500"
'Send the data.
Me.Winsock1.SendData SData
```

End Sub

```
Private Sub Command3_Click()  
'Close the TCP connection socket (disconnect the line).  
Me.Winsock1.Close  
  
End Sub  
  
Private Sub Command4_Click()  
'End the program.  
End  
  
End Sub  
  
Private Sub Command5_Click()  
'Check the state of Winsock.  
'See the Help of Visual Basic for details.  
MsgBox Winsock1.State  
  
End Sub  
  
Private Sub Winsock1_DataArrival(ByVal bytesTotal As Long)  
'The DataArrival event occurs when new data arrives.  
  
Dim RData As String  
'Obtain the current data block and save it as a variant type variable.  
'Read the response from the PLC CPU.  
Me.Winsock1.GetData RData  
MsgBox RData  
  
End Sub
```

Appendix 8 Difference between Ethernet and IEEE802.3

The Ethernet header for the data link layer supported by the QE71 meets the specifications of the Ethernet frame.

The QE71 does not communicate with another node whose Ethernet header for the data link layer has the IEEE 802.3 (ISO/IEC 8802-3) specifications.

1 Ethernet

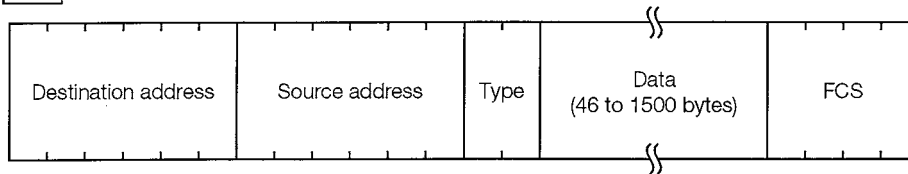

2 IEEE802.3

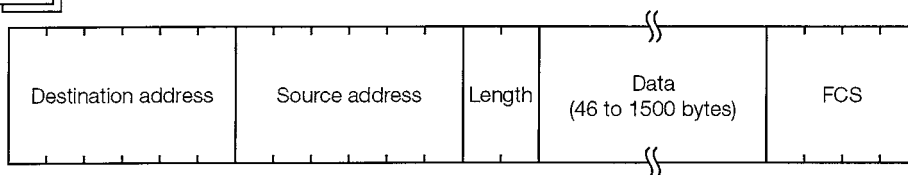

Remarks

The hardware specifications of the QE71 are in accordance with the IEEE802.3.

Appendix 9 QE71 Support's ICMP Protocol

Shows the ICMP types and QE71 processing supported by the QE71.

ICMP type	ICMP name/description	QE71 processing
0	Echo Reply IP packet echo results	The QE71 transmits this message when it receives an Echo Request.
3	Destination Unreachable The IP packet could not reach the partner destination.	The QE71 transmits this message when data is received by a UDP connection that has not been opened.
8	Echo Request IP packet echo request	The QE71 transmits this message when conducting an existence check if the destination existence check is set in the buffer memory. (*1)
Other	—	Ignored by the QE71. (Not yet supported)

- *1 The QE71 can receive 2 ICMP ECHO requests (type 8, PING message) used for existence check, etc., at the same time and conducts the corresponding processing. When 3 or more ICMP ECHO requests are received at the same time the requests from the third and later are ignored. When an ICMP ECHO request is transmitted to the QE71 from the remote node and a response is not returned to the remote node, retransmit the ICMP ECHO request to the QE71.
The QE71 is able to receive a maximum of 1460-byte ICMP message at one time.
Do not send an ICMP message request exceeding 1460 bytes to the QE71.

Appendix 10 Communication Support Tool (MX Component)

MX Component is an ActiveX control library that supports any types of communication paths between IBM PC/AT compatible personal computers and PLCs. It allows the users to establish communication using simple processing only, without having to know about the different communication protocols used in the individual communication.

It also supports various programming languages, allowing for a wide range of application development.

This section provides the overview of the functions provided by MX Component and explains the procedure up to creation of applications.

* Refer to Operating Manual and Programming Manual of MX Component for the details.

Appendix 10.1 Overview of MX Component

This section provides the overview of MX Component.

Different communication paths, operating systems, programming languages, and functions are supported depending on the version of MX Component used.

(1) Support for a wide range of communication paths to PLCs

MX Component supports a wide range of communication paths to PLCs. It is possible to construct systems according to the needs of the users.

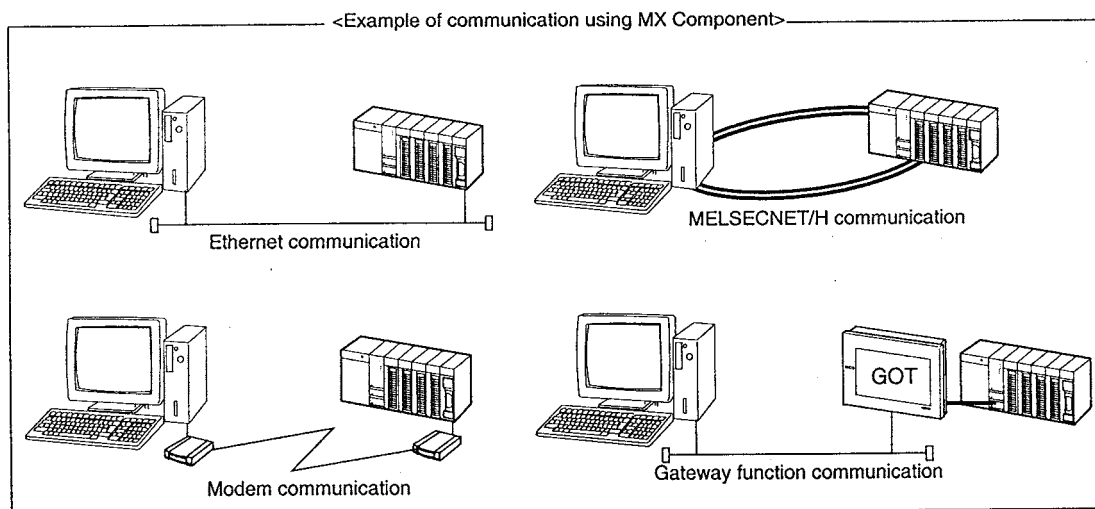

(2) Dramatic improvement of application development efficiency

MX Component provides wizard-style communication setting utilities.

The user only needs to select settings from menus displayed on the screen in an interactive manner to achieve the communication settings required to access the target PLC CPU.

Moreover, once the communication setting has been performed, it is possible to access the PLC CPU simply by specifying the logical station number that is stored via the communication setting utilities.

(3) Support for wide choice of basic operating systems

MX Component can run on IBM PC/AT compatible personal computers running the following basic operating systems:

- Microsoft ® Windows ® 95 Operating System
- Microsoft ® Windows ® 98 Operating System
- Microsoft ® Windows NT ® Workstation Operating System Version 4.0
- Microsoft ® Windows ® Millennium Edition Operating System
- Microsoft ® Windows ® 2000 Professional Operating System
- Microsoft ® Windows ® XP Professional Operating System
- Microsoft ® Windows ® XP Home Edition Operating System

(4) Support for a wide variety of programming languages

MX Component supports the following programming languages. It allows the user to develop a wide range of customized applications.

Programming language	Development software
Visual Basic ®	Microsoft ® Visual Basic ® 6.0
Visual C++ ®	Microsoft ® Visual C++ ® 6.0
VBScript	Text editors and commercially available HTML tools
VBA	Microsoft ® Excel 2000, Microsoft ® Excel 2002, Microsoft ® Access 2000 or Microsoft ® Access 2002

(5) Support for functions dedicated for data communication with PLCs

MX Component provides the functions necessary for data communication with PLCs, including functions for opening/closing communication lines and reading/writing devices. Multi-function communication programs can thus easily be developed with MX Component.

Function name	Function
Connect	Connect Connects a telephone line.
Open	Opens a communication line.
Close	Closes a communication line.
Disconnect	Disconnects a telephone line.
GetErrorMessage	Displays error definition and corrective action.
ReadDeviceBlock	Batch-reads data from devices. (LONG type)
WriteDeviceBlock	Batch-writes data to devices. (LONG type)
ReadDeviceBlock2	Batch-reads data from devices. (SHORT type/INT type)
WriteDeviceBlock2	Batch-writes data to devices. (SHORT type/INT type)
ReadDeviceRandom	Randomly reads data from devices. (LONG type)
WriteDeviceRandom	Randomly writes data to devices. (LONG type)
ReadDeviceRandom2	Randomly reads data from devices. (SHORT type/INT type)
WriteDeviceRandom2	Randomly writes data to devices. (SHORT type/INT type)
SetDevice	Sets one device. (LONG type)
GetDevice	Acquires the data of one device. (LONG type)
SetDevice2	Sets one device. (SHORT type/INT type)
GetDevice2	Acquires data of one device. (SHORT type/INT type)

Function name	Function
ReadBuffer	Reads from buffer memory.
WriteBuffer	Writes to buffer memory.
GetClockData	Reads clock data from PLC CPU.
SetClockData	Writes clock data to PLC CPU.
GetCpuType	Reads a PLC CPU type.
SetCpuStatus	Remote RUN/STOP/PAUSE of PLC CPU
EntryDeviceStatus	Registers device status monitor.
FreeDeviceStatus	Deregisters device status monitor.
OnDeviceStatus	Announces event.

(6) Collecting data on Excel without programming

Using MX component and MX Sheet (SWnD5C-SHEET-E) allows users to collect PLC device data on Excel with only simple setting and without any programming.

Appendix 10.2 Usage Procedure of MX Component

This section explains the procedure for creating programs and sample programs using MX Component.

(1) Procedure for creating programs

The procedure for creating programs is outlined below.

The usage procedure below uses Visual Basic ® as an example.

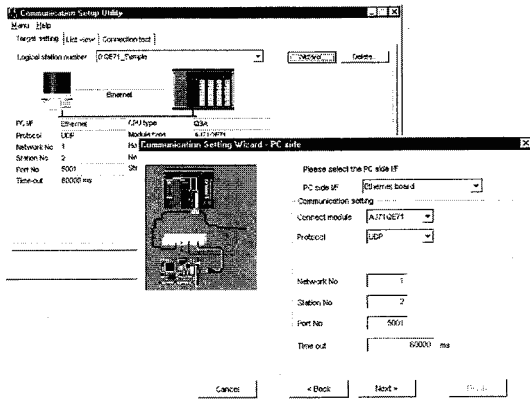

- 1) Perform the communication settings from a IBM PC/AT compatible personal computer to the PLC by following the wizard. (Some types of controls are set only by programs without using the wizard.)

The wizard allows the user to perform the settings required for the communication such as logical station number, connected module type, and PLC to be connected.

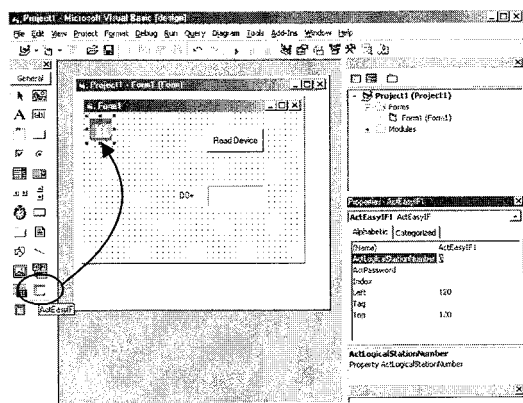

- 2) Paste the ACT control icon onto the form and assign the logical station number set in step 1 to the property of the pasted control.

```

Command1 Click
Private Sub Command1_Click()
    ret = ActEasyIF1.GetDevice("D0", lpData(0))
    Label1.caption = lpData(0)
End Sub
    
```

- 3) Use the functions provided by the software to write a program that reads the device data

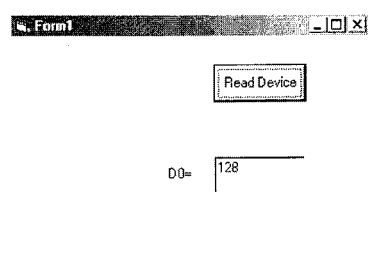

Completed

(2) Sample program

The following sample program reads D0 to D4 (five points) of the target PLC using the logical station number.

- (a) When Visual Basic® is used
 - 1) Screen example (Form1)

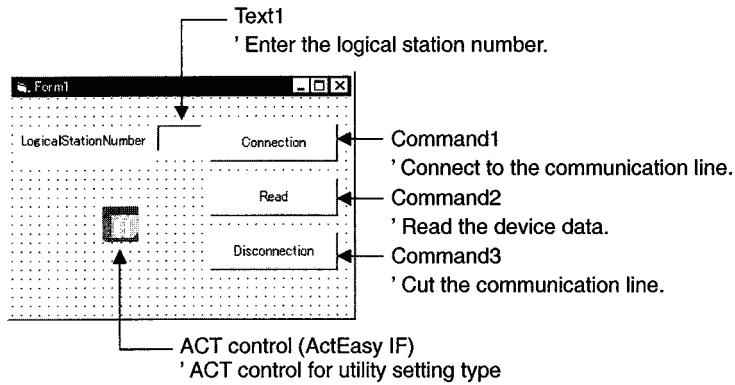

2) Program example

```
Private Sub Command1_Click()
' *****
' Connection
' *****
Dim rtn As Long
' Get LogicalstationNumber
ActEasyIF1.ActLogicalStationNumber = Val(Text1.Text)
' Connection
rtn = ActEasyIF1.Open()
If rtn = 0 Then
MsgBox "The connection was successful"
Else
MsgBox "Connection Error:" & Hex(rtn)
End If
End Sub

Private Sub Command2_Click()
' *****
' Read
' *****
Dim rtn As Long
Dim idata(5) As Integer
' D0-D4 are read
rtn = ActEasyIF1.ReadDeviceBlock2("D0", 5, idata(0))
If rtn = 0 Then
MsgBox "D0-D5 = " & idata(0) & ", " & idata(1) & ", " & idata(2) & ", " & idata(3) & ", " & idata(4)
Else
MsgBox "Read Error:" & Hex(rtn)
End If
End Sub
```

```

Private Sub Command3_Click()
'*****
' Disconnection
'*****
Dim rtn As Long
' Disconnection
rtn = ActEasyIF1.Close()
If rtn = 0 Then
MsgBox "The disconnection was successful"
Else
MsgBox "Disconnection Error:" & Hex(rtn)
End If
End Sub

```

(b) When Visual C++ ® is used

```

//*****
// Connection
//*****
void CVCDlg::OnOpen()
{
long lRet;
CString szMessage;

UpdateData();
// Get LogicalStationNumber
m_actEasyIF.SetActLogicalStationNumber ( m_lLogicalStationNumber );
// Connection
lRet = m_actEasyIF.Open();
if ( lRet == 0 ) {
MsgBox ( "The connection was successful" )
} else {
szMessage.Format ( "Connection Error: %x", lRet );
MsgBox ( szMessage )
}
}
}

```

```
// *****
// Read
// *****
void CVCDlg::OnRead()
{
    long IRet;
    short sData[5];
    CString szMessage;
    // D0-D4 are read
    IRet = m_actEasyIf. ReadDeviceBlock2 ( "D0", 5, sData );
    if ( IRet == 0 ) {
        szMessage. Format ( "D0-D5 = %d, %d, %d, %d, %d",
                           sData[0], sData[1], sData[2], sData[3], sData[4] );
        MessageBox ( szMessage );
    } else {
        szMessage. Format ( "Read Error: %x", IRet );
        MessageBox ( szMessage )
    }
}

// *****
// Disconnection
// *****
void CVCDlg::OnOpen()
{
    long IRet;
    CString szMessage;
    // Disconnection
    IRet = m_actEasyIF. Close();
    if ( IRet == 0 ) {
        MessageBox ( "The disconnection was successful" )
    } else {
        szMessage. Format ( "Disconnection Error: %x", IRet );
        MessageBox ( szMessage )
    }
}
}
```

Appendix 11 Index

(A)

Access to Q4ARCPU	4-22
Access Station -1 to 2	9-21
Accessible Device	10-17
Accessible Module	10-94
Accessible Range	
(Data in the PLC CPU Exchange) (Item 9.1)	
(File Transfer (FTP))	13-5
(Fixed Buffer Exchange (With Procedure)) ..	6-1
(Fixed Buffer Exchange (Without Procedure))...	7-1
(MELSECNET/10 Relay Exchange)	15-1
(Random Access Buffer Exchange)	8-1
Active Open	5-28
AJ71QE71N-B2	1-1
AJ71QE71N-B5	1-1
AJ71QE71N-T	1-1
AJ71QE71N3-T	1-1
Application Data	
(Data in the PLC CPU Exchange)	10-1
(Fixed Buffer Exchange (With Procedure))...	6-7
(Fixed Buffer Exchange (Without Procedure))...	7-7
(Random Access Buffer Exchange)	8-4
ARP	1-4
Attributes (File)	10-116, 13-17, 13-27
AUI Cable (Transceiver Cable)	2-5
Automatic Open UDP Port	5-60
Automatic Open UDP Port No. Setting	5-10
Automatic Start Up Mode	5-4, 5-6
Automatic Start Up Mode Setting (SW3)	4-4
A1SJ71QE71N-B2	1-1
A1SJ71QE71N-B5	1-1
A1SJ71QE71N-T	1-1
A1SJ71QE71N3-T	1-1

(B)

Buffer Memory	
Exchange Instruction During STP	16-2
Exchange Parameter	5-18
FTP Parameter	13-6
Initial Processing Parameter	5-7
List	3-22
Router Relay Parameter	12-3
Station No. <-> IP Information parameter ..	15-15
Subnet Mask	11-3

(C)

Channel 1 to 8 (Data Link Command)	14-6
Character Area (A area/B area/C area)	10-3
Cheapernet (10 BASE 2)	1-1
Class	11-4
Client	1-11
Close Processing (Procedure)	5-23
Example Close Processing Program	5-45
Pairing	5-40
TCP/UDP	5-34
Cluster	10-108
COM.ERR.LED turn off	3-20, 17-28
COM.ERR.LED turn on	17-17
Command Format	
(Data in the PLC CPU Exchange)	10-1
(Fixed Buffer Exchange (With Procedure))...	6-7
(Fixed Buffer Exchange (Without Procedure))...	7-7
(Random Access Buffer Exchange)	8-4, 8-9
Command List (Data in the PLC CPU Exchange)	
E71 Command	9-22
QE71 Command	9-16
Command List (File Transfer (FTP))	
FTP Server Support Command	13-3
QE71 Dedicated Command	13-4
Communication Format Selection (TCP/UDP) ..	5-28
Comparison with E71S3	1-14
Comparison with Existing Modules	1-14
Conversion Format Setting (Special Function Setting) ...	5-8
CPU Exchange Timing Setting (SW7)	4-4
CPU monitoring timer	10-5

(D)

Data Code Selection	3-3
Data Code Setting (SW2)	4-4
Data Format	
(Data in the PLC CPU Exchange)	10-1
(Fixed Buffer Exchange (With Procedure)) ..	6-9
(Fixed Buffer Exchange (Without Procedure))...	7-7
(Random Access Buffer Exchange)	8-4
Data Link Command	14-2, 14-6
Default Router	12-1
Default Router IP Address	12-3
Device Code	10-17
Device Memory Extension Specification	10-66

Device Range	10-17, 10-19
Dip Switches (SW1 to SW8)	4-4
Display LED	4-5
Drive Name	10-110, 13-15, 13-17

(E)

End Code	
(Data in the PLC CPU Exchange)	10-7
(Fixed Buffer Exchange (With Procedure)) ..	6-10
(Random Access Buffer Exchange)	8-8
End Code (Error Code, End Code) List (Refer to Error Code)	
End Processing Procedure	
Automatic Start Up Mode	5-21
Request Start Up Mode	5-13
Error Code (Error Code, End Code) List	
Buffer Memory Storage Destination	17-1
End Codes Returned to the Remote Node ...	17-2
Error Codes Returned to the Remote Node ..	17-4
Error Codes Stored in the Buffer Memory ...	17-5
Error Codes of Data Link Command	17-5
File Transfer (FTP) Response Code	13-18
Error Log Area	5-57
Ethernet	A-17
Ethernet (10 BASE 5)	1-1
Ethernet diagnostics	17-28
Ethernet parameters	4-19, 15-10
Example End Processing Program	
Automatic Start Up Mode	5-23
Request Start Up Mode	5-14
Example Initial Processing Program	
Automatic Start Up Mode	5-23
Request Start Up Mode	5-14
Example Open Processing Program	5-45
Exchange Address Setting	5-30
Exchange Condition Settings	4-4
Exchange Parameter	5-25
Exchange Procedure	
(File Transfer)	13-8
(MELSECNET/10 Relay Exchange)	15-23
(Overall)	5-2
Exchange State Storage Area	5-50
Exchange While the PLC CPU is in the STOP status	1-13, (Chapter 16)
Exchangeable Range (Accessible Range)	
(Data in the PLC CPU Exchange)	(Item 9.1)
(File Transfer (FTP))	13-5
(Fixed Buffer Exchange (With Procedure)) ..	6-1

(Fixed Buffer Exchange	
(Without Procedure))	7-1
(MELSECNET/10 Relay Exchange)	15-2
(Random Access Buffer Exchange)	8-1
Existence Check	1-13
(Processing)	5-11
(Setting)	5-9, 5-26
Extension Specification (Device Memory) ...	10-66
E71	A-16
E71 (Existing module)	A-16
E71S3 (Existing module)	A-16
E71 Command	9-22

(F)

FAT	10-108
File Attributes	10-116, 13-17, 13-27
File Path Name	13-15
File Transfer Function	1-11, (Chapter 13)
Fixed Buffer Exchange	1-6
(With Procedure)	(Chapter 6)
(Without Procedure)	(Chapter 7)
FTP (Client)	13-1
FTP (Server)	1-11, 13-1
FTP Command	13-3, 13-15
QE71 Dedicated Command	13-4, 13-26
QE71 Support Command	13-3, 13-19
FTP Function Setting	5-8, 13-6, 13-15
(Special Function Setting)	
FTP Parameter	4-19
ACPU Monitoring Timer	13-6
Command Input Monitoring Timer	13-7
FTP Log in Name	13-6
Password	13-6
FTP Server Response Code	13-18
Full Passive Open	5-28

(G)

GPP (GPPQ, GPPW)	A-17, 15-1, 15-6
------------------------	------------------

(H)

Header	
(Data in the PLC CPU Exchange)	10-1
(Fixed Buffer Exchange	
(With Procedure))	6-7
(Fixed Buffer Exchange	
(Without Procedure))	7-7

- (Random Access Buffer Exchange) 8-4
 Host address 11-4
 How to Check an Error Through GPPW 17-27
- (I)**
- ICMP 1-4, APP.-32
 Initial Processing Parameter 5-7
 Initial Processing Procedure
 Automatic Start Up Mode 5-21
 Request Start Up Mode 5-13
 Initial Timing Setting (SW8) 4-4
 Interface (10 BASE 5 Signal Layout) 2-5
 IP 1-4
 IP Address 4-19, 11-4
 Local Station QE71 Setting 5-7
 Remote Node Setting 5-31
- (K)**
- Keyword 10-109, 13-15, 13-28
- (L)**
- Line Processing Selection
 During TCP Time Out Error 4-4
 List of I/O Signals 3-10
- (M)**
- MELSECNET/10 Relay Exchange(Chapter 15)
 MELSECNET/10 Relay Exchange
 Convert Form 15-13, 15-17
 Ethernet Parameters 15-10
 Routing Parameters 15-11
 Monitor Conditions Setting 10-30, 10-35
- (N)**
- Network address 11-4
 Network No. (Data in the PLC CPU Exchange) 10-4
 (Example Setting) 9-4, 9-9, 9-14
 N/W Module A-17, 14-6
- (O)**
- Open Processing (Procedure) 5-24
 Pairing 5-40
 TCP/UDP 5-32
- (P)**
- Pairing
 Open Processing and
 Close Processing Procedure 5-40
 Open Setting 5-27
 Parameter setting by GPPW 4-18
 Parameter (Setting Value) Registration (EEPROM)
 1-13
 Remote Node 10-158
 Sequence Program 4-24, 14-46
 Passive Open 5-28
 PLC No. (Data in the PLC CPU Exchange) ... 10-4
 Example Setting 9-4, 9-9, 9-14
 Physical Address (Random Access) 8-13
 Procedures Up to Operation 4-1
 PING test 5-15
- (Q)**
- QE71 A-16
 QE71 (Existing module) A-16
 QE71 Command 9-16
 QE71 Dedicated Command (FTP Command) .. 13-4
 QnA Header 10-3
- (R)**
- Random Access Buffer Exchange 1-8, (Chapter 8)
 READ (Data Link Command) 14-18
 Reading/Writing Data in the PLC CPU
 1-9, (Chapter9, Chapter 10)
 RECV (Data Link Command) 14-12
 Register/Read/Clear in the EEPROM
 Processing from the Remote Node 10-158
 Processing from the PLC CPU 4-24, 14-46
 Related Manual A-15
 Relationship of the Setting
 Parameters and Functions 4-20
 Remote RUN/STOP (PLC CPU)
 Processing from the PLC CPU 14-36
 Processing from the Remote Node 10-100
 REQ (Data Link Command) 14-2
 Clock Data Read/Write 14-43
 EEPROM Data Read/Write 14-46
 Status Control 14-36
 Request Start Up Mode 5-2, 5-6
 Response Code (File Transfer (FTP)) 13-18

Response Format	
(Data in the PLC CPU Exchange) ...	10-6, 10-7
(Fixed Buffer Exchange (With Procedure))	
.....	6-8
(Random Access Buffer Exchange)	8-5, 8-9
Router IP Address	12-6
Router Relay Function	1-12, (Chapter 12)
Router Relay Function Setting (Special Function Setting)	
.....	5-8
Routing Relay Parameters	4-19, 12-3
Routing Relay Parameter Setting	12-3
Routing Parameters	4-19, 15-12
(S)	
SEND (Data Link Command)	14-8
Setting (Hardware)	
Automatic Start Up Mode (SW3)	4-4
CPU Exchange Timing Setting (SW7)	4-4
Data Code Setting (SW2)	4-4
Initial timing Setting (SW8)	4-4
Line Processing Selection During	
TCP Time Out Error (SW1)	4-4
Operation Mode Settings	4-3
Setting (Software)	
Data in the PLC CPU Exchange	
Exchange Instruction during STOP	16-2
Exchange Parameter (Open Processing)	
Communication Format (Protocol) Setting	
.....	5-28
Destination Existence Check Setting ..	5-26
Fixed Buffer Exchange Procedure Existence Setting	
.....	5-28
Open Method Setting	5-28
Pairing Open Setting	5-26
QE71's Port No. Setting	5-30
Remote Node Ethernet Address Setting	
.....	5-31
Remote Node IP Address Setting	5-31
Remote Node Port No. Setting	5-31
Usage Available Setting for Fixed Buffer	
.....	5-26
Initial Processing Parameter	
Automatic Open UDP Port No.	5-10
Destination Existence Check Interval Timer Value	
.....	5-9
Destination Existence Check Start	
Interval timer Value	5-9
Local Station QE71's IP Address	5-7-1
Number of Retransmit Tries for	
Destination Existence Check	5-9
Router Relay Information (Router Relay Function)	
Default Router IP Address	12-3
Number of Registered Routers	12-3
Router IP Address	12-6
Subnet Address	12-4
Special Function Setting	
Conversion Method Setting	5-8
FTP Function Setting	5-8
IP Setup Timer Value	5-9
Response Monitoring Timer Value	5-9
Router Relay function Setting	5-8
TCP End Timer Value	5-9
TCP Retransmit Timer Value	5-9
TCP ULP Time Out Value	5-8
TCP Zero Window Timer Value	5-8
Subnet Mask	
Subnet Mask Field	11-3
Setting the Ethernet FTP parameters	
.....	4-19, 13-6
Setting the Ethernet router relay parameter	
.....	4-19, 12-3
Setting the Ethernet Station No. <-> IP information	
.....	4-19, 15-14
Setting the MNET(II) MNET/10(H) Ethernet routing information	
.....	4-19, 15-12
Setting the number of MNET(II) MNET/10(H) Ethernet cards	
.....	4-19, 15-10
Setting Value (Parameter) Registration (EEPROM)	
.....	1-13
Remote Node	10-158
Sequence Program	4-24, 14-46
Simultaneous Broadcast Function (UDP/IP)	
.....	1-11, 7-8, 14-4
Special Function Menu	(Previous Chapter 11)
Specification -1 to 5	10-66
SREAD (Data Link Command)	14-18
State Control (PLC CPU)	
Processing from the PLC CPU	14-36
Processing from the Remote Node	10-100
Station No. <-> IP Information	
Destination Station Network # and Station Number	
.....	15-14, 15-16
MELSECNET/10 Routing Net Mask Pattern	
.....	15-14, 15-16

Parameters	15-13	10 BASE 2 (Cheapernet) Connection	2-7, 4-15
The Number of Conversion Table Data .	15-16	10 BASE 5 (Ethernet) Connection	2-5, 4-14
Station No. <-> IP Information Parameters		10 BASE-T Connection	2-8, 4-17
.....	4-19, 15-14		
Subheader			
(Data in the PLC CPU Exchange)	10-2		
(Fixed Buffer Exchange (With Procedure))..	6-8		
(Random Access Buffer Exchange)	8-5		
Subnet Address	11-1, 12-4		
Subnet Mask.....	11-1		
Subnet Mask Field	11-3		
Supported Systems	2-3		
SW1 to SW8 (Dip Switch).....	4-4		
SWRITE (Data Link Command)	14-21		
System configuration	(Chapter 2)		

(T)

TCP	1-3
Terms/Abbreviations	A-16
Text	
(Data in the PLC CPU Exchange)	10-2
(Fixed Buffer Exchange	
(With Procedure))	6-9
(Fixed Buffer Exchange	
(Without Procedure))	7-7
(Random Access Buffer Exchange)	8-7
Transceiver Cable (AUI Cable)	2-5

(U)

UDP	1-3
Unpassive Open.....	5-29
Usage Available Setting	5-26
(Example Setting)	5-29

(W)

WRITE (Data Link command)	14-21
---------------------------------	-------

(Z)

ZNRD (Data Link Command)	14-30
ZNWR (Data Link command)	14-31

(1)

WARRANTY

Please confirm the following product warranty details before using this product.

1. Gratis Warranty Term and Gratis Warranty Range

If any faults or defects (hereinafter "Failure") found to be the responsibility of Mitsubishi occurs during use of the product within the gratis warranty term, the product shall be repaired at no cost via the sales representative or Mitsubishi Service Company.

However, if repairs are required onsite at domestic or overseas location, expenses to send an engineer will be solely at the customer's discretion. Mitsubishi shall not be held responsible for any re-commissioning, maintenance, or testing onsite that involves replacement of the failed module.

[Gratis Warranty Term]

The gratis warranty term of the product shall be for one year after the date of purchase or delivery to a designated place.

Note that after manufacture and shipment from Mitsubishi, the maximum distribution period shall be six (6) months, and the longest gratis warranty term after manufacturing shall be eighteen (18) months. The gratis warranty term of repair parts shall not exceed the gratis warranty term before repairs.

[Gratis Warranty Range]

- (1) The range shall be limited to normal use within the usage state, usage methods and usage environment, etc., which follow the conditions and precautions, etc., given in the instruction manual, user's manual and caution labels on the product.
- (2) Even within the gratis warranty term, repairs shall be charged for in the following cases.
 1. Failure occurring from inappropriate storage or handling, carelessness or negligence by the user. Failure caused by the user's hardware or software design.
 2. Failure caused by unapproved modifications, etc., to the product by the user.
 3. When the Mitsubishi product is assembled into a user's device, Failure that could have been avoided if functions or structures, judged as necessary in the legal safety measures the user's device is subject to or as necessary by industry standards, had been provided.
 4. Failure that could have been avoided if consumable parts (battery, backlight, fuse, etc.) designated in the instruction manual had been correctly serviced or replaced.
 5. Failure caused by external irresistible forces such as fires or abnormal voltages, and Failure caused by force majeure such as earthquakes, lightning, wind and water damage.
 6. Failure caused by reasons unpredictable by scientific technology standards at time of shipment from Mitsubishi.
 7. Any other failure found not to be the responsibility of Mitsubishi or that admitted not to be so by the user.

2. Onerous repair term after discontinuation of production

- (1) Mitsubishi shall accept onerous product repairs for seven (7) years after production of the product is discontinued. Discontinuation of production shall be notified with Mitsubishi Technical Bulletins, etc.
- (2) Product supply (including repair parts) is not available after production is discontinued.

3. Overseas service

Overseas, repairs shall be accepted by Mitsubishi's local overseas FA Center. Note that the repair conditions at each FA Center may differ.

4. Exclusion of loss in opportunity and secondary loss from warranty liability

Regardless of the gratis warranty term, Mitsubishi shall not be liable for compensation of damages caused by any cause found not to be the responsibility of Mitsubishi, loss in opportunity, lost profits incurred to the user by Failures of Mitsubishi products, special damages and secondary damages whether foreseeable or not, compensation for accidents, and compensation for damages to products other than Mitsubishi products, replacement by the user, maintenance of on-site equipment, start-up test run and other tasks.

5. Changes in product specifications

The specifications given in the catalogs, manuals or technical documents are subject to change without prior notice.

6. Product application

- (1) In using the Mitsubishi MELSEC programmable logic controller, the usage conditions shall be that the application will not lead to a major accident even if any problem or fault should occur in the programmable logic controller device, and that backup and fail-safe functions are systematically provided outside of the device for any problem or fault.
- (2) The Mitsubishi programmable logic controller has been designed and manufactured for applications in general industries, etc. Thus, applications in which the public could be affected such as in nuclear power plants and other power plants operated by respective power companies, and applications in which a special quality assurance system is required, such as for Railway companies or Public service purposes shall be excluded from the programmable logic controller applications.

In addition, applications in which human life or property that could be greatly affected, such as in aircraft, medical applications, incineration and fuel devices, manned transportation, equipment for recreation and amusement, and safety devices, shall also be excluded from the programmable logic controller range of applications.

However, in certain cases, some applications may be possible, providing the user consults their local Mitsubishi representative outlining the special requirements of the project, and providing that all parties concerned agree to the special circumstances, solely at the users discretion.

Microsoft Windows, Microsoft Windows NT are registered trademarks of Microsoft Corporation in the United States and other countries.

Ethernet is registered trademark of Xerox Corporations.

Visual basic is a registered trademark of the Microsoft Co.,Ltd.

Other company names and product names used in this document are trademarks or registered trademarks of respective companies.

For QnA Ethernet Interface Module User's Manual

MODEL	QE71N-U-SY-E
MODEL CODE	13JR33
SH(NA)-080146-D(0606)MEE	

 **MITSUBISHI ELECTRIC CORPORATION**

HEAD OFFICE : TOKYO BUILDING, 2-7-3 MARUNOUCHI, CHIYODA-KU, TOKYO 100-8310, JAPAN
NAGOYA WORKS : 1-14, YADA-MINAMI 5-CHOME, HIGASHI-KU, NAGOYA, JAPAN

When exported from Japan, this manual does not require application to the
Ministry of Economy, Trade and Industry for service transaction permission.

Specifications subject to change without notice.